



Service Repair Manual

Models

314C and 314C CR Excavator

[Previous Screen](#)

Product: EXCAVATOR

Model: 314C EXCAVATOR SNY

Configuration: 314C CR Excavator SNY00001-UP (MACHINE) POWERED BY 3064 Engine

Disassembly and Assembly

314C Excavator Excavator Systems

Media Number -REN6613-05

Publication Date -01/03/2017

Date Updated -13/03/2017

i04126149

Final Drive and Travel Motor - Disassemble

SMCS - 4050-015; 4351-015

S/N - KJA277-UP

S/N - PCA1658-UP

S/N - SNY499-UP

Disassembly Procedure

Table 1

Required Tools			
Tool	Part Number	Part Description	Qty
A	138-7573	Link Bracket	3
B	1P-2420	Transmission Repair Stand	1
C	8T-6699	Bolts	2
D	1P-0074	Slide Hammer Puller Gp	1
	4C-5666	Threaded Adapter	1
	123-6702	Backlash Gauge Gp	1
E	1P-0510	Driver Gp	1
F	8H-0663	Bearing Puller Gp	1
G	1P-1863	Retaining Ring Pliers	1
H	9U-7346	Spanner Wrench As	1

Start By:

- a. Remove the final drive and the travel motor. Refer to Disassembly and Assembly Manual , "Final Drive and Travel Motor - Remove".

NOTICE

Care must be taken to ensure that fluids are contained during performance of inspection, maintenance, testing, adjusting, and repair of the product. Be prepared to collect the fluid with suitable containers before opening any compartment or disassembling any component containing fluids.

Refer to Special Publication, NENG2500, "Dealer Service Tool Catalog" for tools and supplies suitable to collect and contain fluids on Cat products.

Dispose of all fluids according to local regulations and mandates.



Personal injury can result from hydraulic oil pressure and hot oil.

Hydraulic oil pressure can remain in the hydraulic system after the engine has been stopped. Serious injury can be caused if this pressure is not released before any service is done on the hydraulic system.

Make sure all of the work tools have been lowered to the ground, and the oil is cool before removing any components or lines. Remove the oil filler cap only when the engine is stopped, and the filler cap is cool enough to touch with your bare hand.

1. Thoroughly clean the outside of the final drive and travel motor prior to disassembly.
 2. Remove the sprocket from the final drive and the travel motor. The weight of the sprocket is approximately 39 kg (85 lb).
 3. Mark the alignment of the final drive and travel motor for reassembly purposes. The parts must be reinstalled in the original locations.
-

<https://www.ebooklibonline.com>

Hello dear friend!

Thank you very much for reading.

Enter the link into your browser.

The full manual is available for immediate download.

<https://www.ebooklibonline.com>

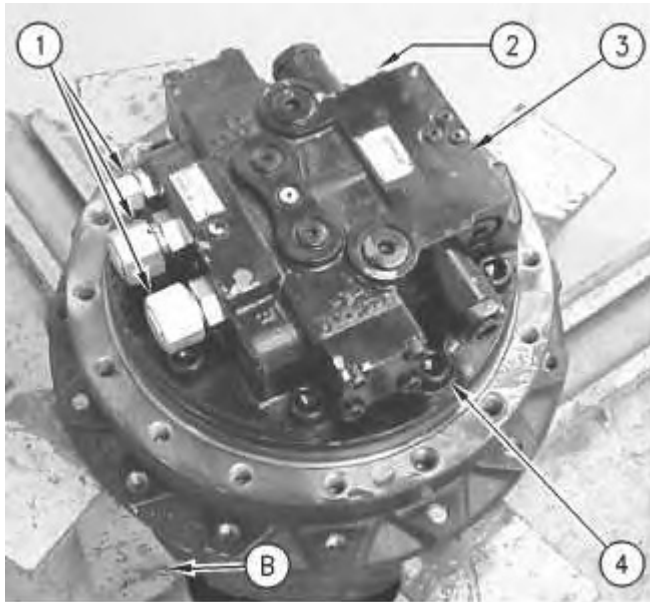
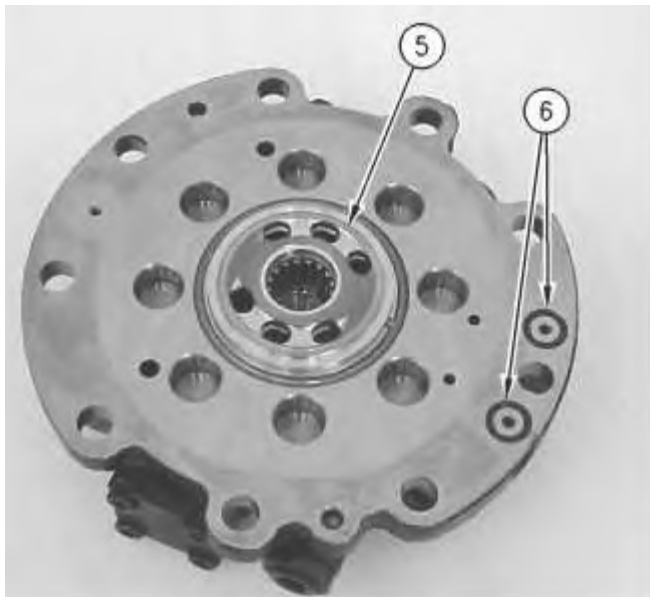

Illustration 1

g00940682

4. Use Tooling (A) and a suitable lifting device to position the final drive and the travel motor onto Tooling (B). The combined weight of the final drive and travel motor is approximately 170 kg (375 lb).
5. Drain the oil from the final drive into a suitable container for storage or for disposal. Refer to Operation and Maintenance Manual, "Capacities (Refill)" for the capacity of the final drive.
6. Remove fittings (1). Remove fittings (2) from traction control valve (3).
7. Remove nine bolts (4) that secure traction control valve (3) to the final drive.
8. Use two persons to remove traction control valve (3) from the final drive. The weight of travel brake valve (3) is approximately 27 kg (60 lb).



9. Remove valve plate (5) and O-ring seal (6).

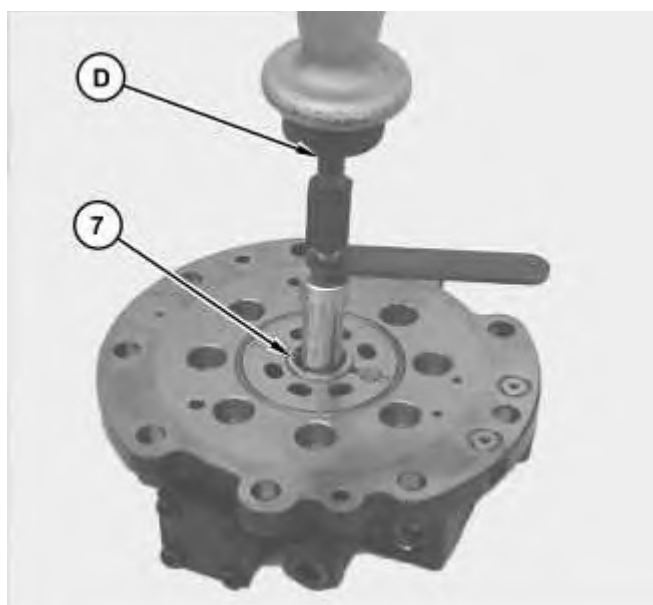

Illustration 3

10. Use Tooling (D) to remove bearing (7).

Disassembly of the Counterbalance Valve



Illustration 4

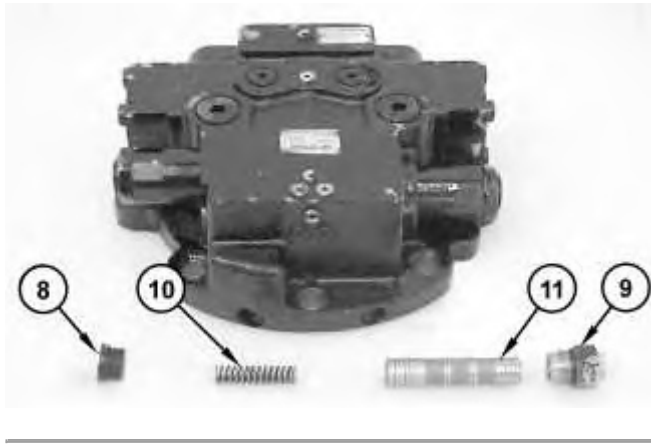

Illustration 5

g01405227

WARNING

Personal injury can result from being struck by parts propelled by a released spring force.

Make sure to wear all necessary protective equipment.

Follow the recommended procedure and use all recommended tooling to release the spring force.

1. Position the counterbalance valve, as shown. Remove plug (8) and adapter (9).
2. Remove spring (10) and spool (11).



Illustration 6

g01405232

3. Remove relief valve assemblies (12).

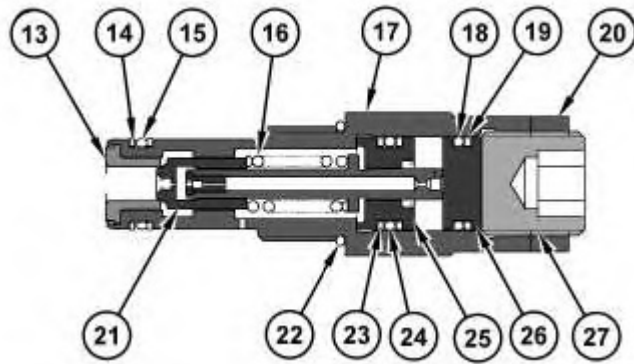

Illustration 7

g01405243



Personal injury can result from being struck by parts propelled by a released spring force.

Make sure to wear all necessary protective equipment.

Follow the recommended procedure and use all recommended tooling to release the spring force.

4. Remove seat (13). Seat (13) is pressed onto valve (17). Use new parts if seat (13) or valve (17) is damaged. Do not disassemble these components. Make sure that you reuse the other component.
 5. Remove backup ring (14) and O-ring seal (15).
 6. Remove O-ring seal (22).
 7. Remove nut (20).
 8. Remove screw (27).
 9. Remove stopper (26). Remove backup ring (19) and O-ring seal (18) from stopper (19).
 10. Remove valve (21), piston (25), and spring (16) from the housing.
 11. Remove backup ring (23) and O-ring seal (24) from piston (25).
-



Illustration 8

g01405284

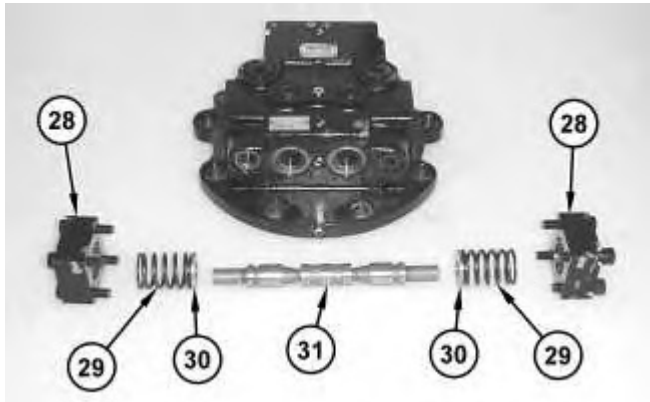

Illustration 9

g01405299

WARNING

Personal injury can result from being struck by parts propelled by a released spring force.

Make sure to wear all necessary protective equipment.

Follow the recommended procedure and use all recommended tooling to release the spring force.

-
12. Remove covers (28) and the O-ring seals.
 13. Remove springs (29), guides (30), and spool assembly (31).
-

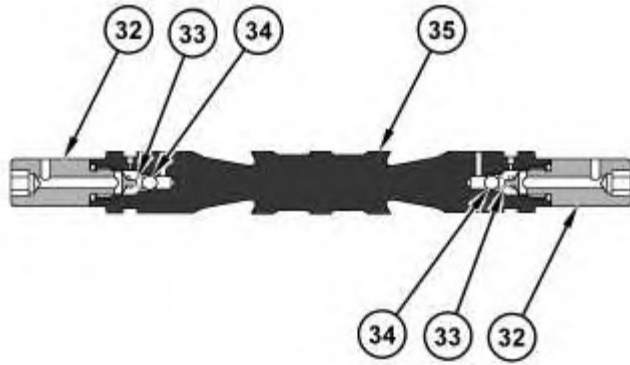

Illustration 10

g01405345

 **WARNING**

Personal injury can result from being struck by parts propelled by a released spring force.

Make sure to wear all necessary protective equipment.

Follow the recommended procedure and use all recommended tooling to release the spring force.

14. Remove valve (32), spring (33), and ball (34) from one end of spool (35). Repeat for the other end of spool (35).

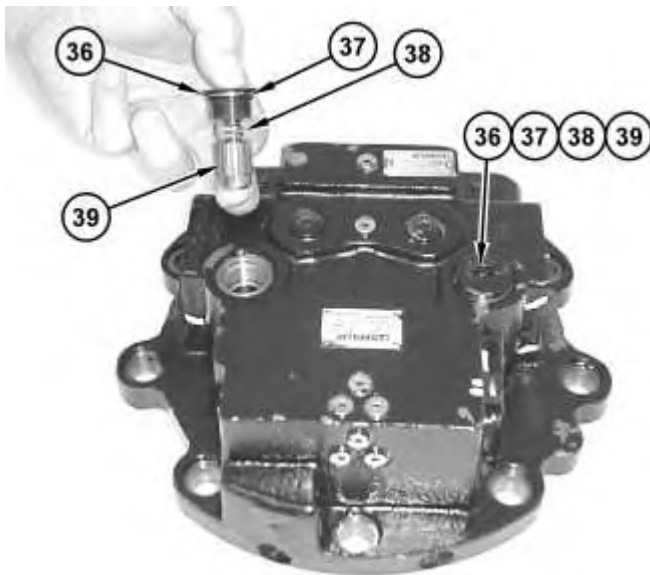

Illustration 11

g01405633

WARNING

Personal injury can result from being struck by parts propelled by a released spring force.

Make sure to wear all necessary protective equipment.

Follow the recommended procedure and use all recommended tooling to release the spring force.

15. Remove plug (36), spring (38), and piston (39) from both sides of the housing assembly.
16. Remove O-ring seal (37) from each plug (36).

Note: Remove the remaining allen head bolts from the housing assembly for cleaning purposes, if necessary. Each allen head bolt has an O-ring seal. Check the O-ring seal for wear or for damage. Replace the O-ring seal, if necessary.

Disassembly of the Travel Motor



Illustration 12

g01405794

1. Remove O-ring seal (40) and springs (41).
-

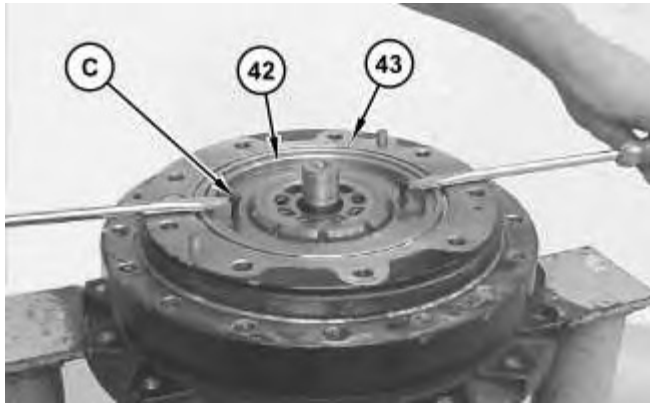

Illustration 13

g01405828

2. Install Tooling (C) onto piston assembly (42). Use Tooling (C) and a suitable prybar to remove piston assembly (42) from body (43).

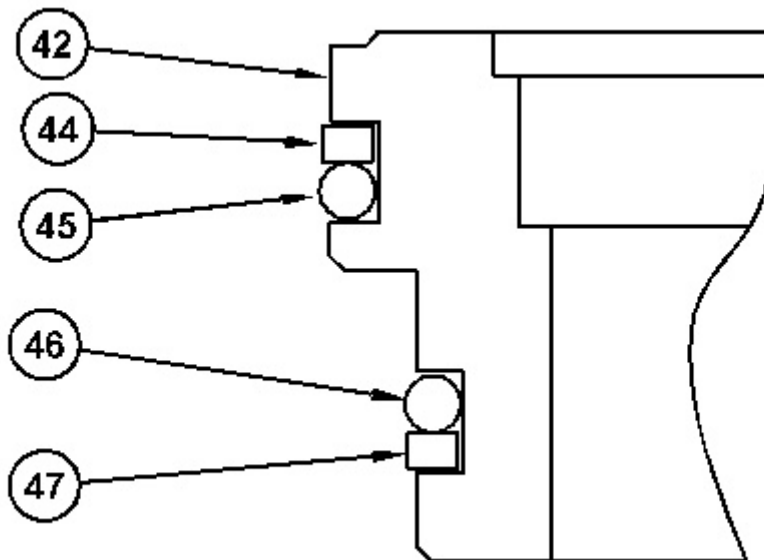

Illustration 14

g01405855

3. Remove O-ring seals (45) and (46) from piston assembly (42). Remove backup rings (44) and (47) from piston assembly (42).



Illustration 15

g01405867

4. Use suitable drivers or a suitable lever to remove guide assembly (48).

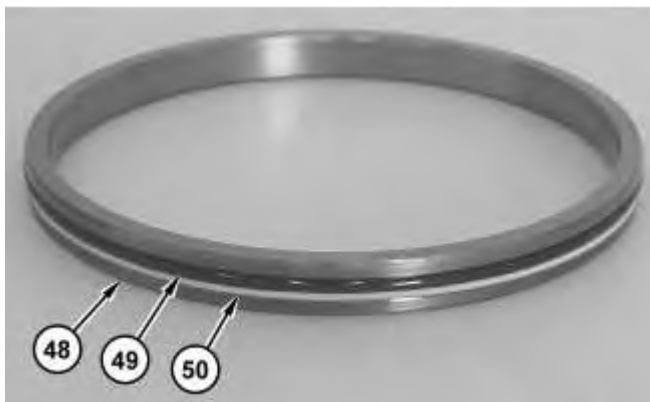

Illustration 16

g01405885

5. Remove O-ring seal (49) and backup ring (50) from guide assembly (48).

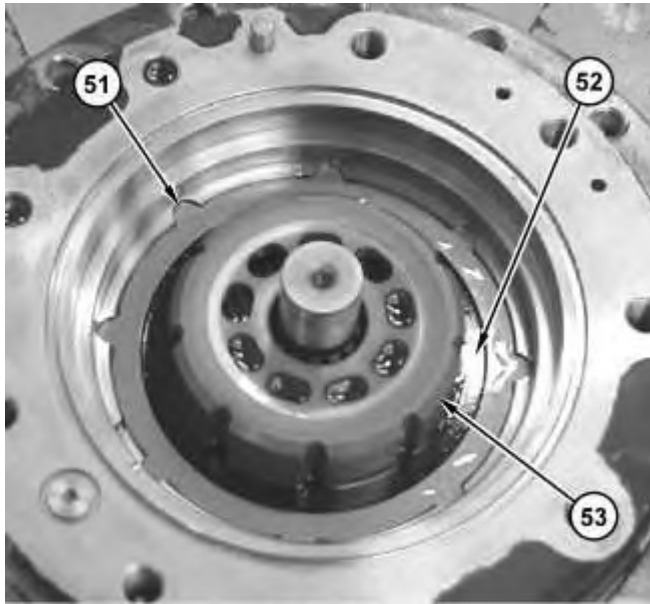

Illustration 17

g01406117

6. Remove four separator plates (51) and four friction plates (52). Note the alternating order of separator plates (51) and friction plates (52) for assembly purposes.

Note: Do not allow the components of barrel assembly (53) to come apart while you remove barrel assembly (53). The components of barrel assembly (53) must be reinstalled into the original positions.

Note: Oil will drain from the final drive. Place a suitable container under the final drive for storage or disposal. Refer to Operation and Maintenance Manual, "Capacities (Refill)" for the fluid capacity of the final drive.

7. Position the final drive horizontally.
8. Remove barrel assembly (53).



Note: Mark the component locations for assembly purposes before you disassemble barrel assembly (53).

9. Remove piston assemblies (54) and retainer (55) from barrel assembly (53).

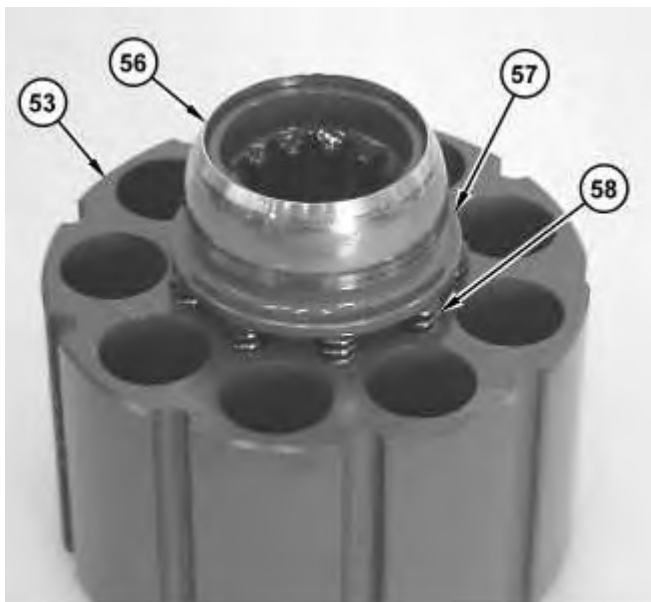

Illustration 19



Personal injury can result from being struck by parts propelled by a released spring force.

Make sure to wear all necessary protective equipment.

Follow the recommended procedure and use all recommended tooling to release the spring force.

-
10. Remove retainer (56), spacer (57), and springs (58) from barrel assembly (53).
-

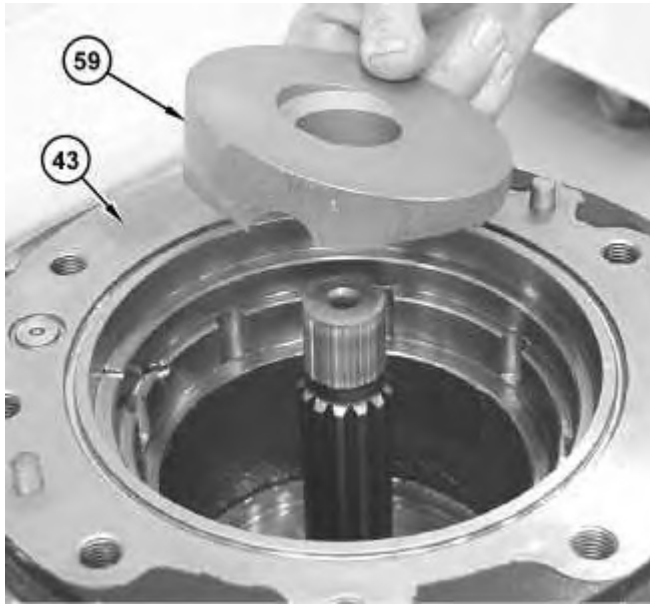

Illustration 20

g01406263

11. Put location marks on cam plate (59) for assembly purposes. Make sure that the thick end of cam plate (59) is adjacent to the opening that is across body (43). Remove cam plate (59).



Illustration 21

g01406329

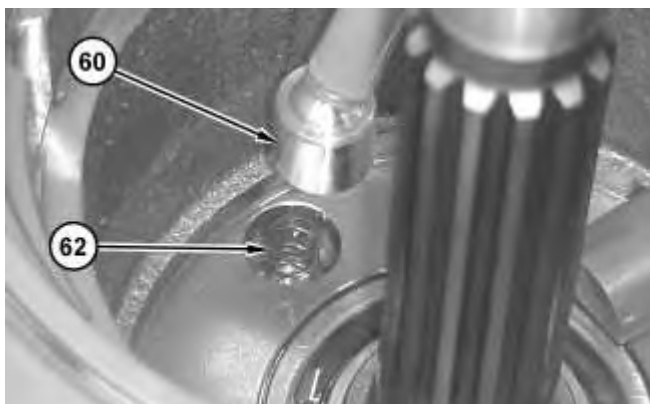

Illustration 22

g01406338

WARNING

Personal injury can result from being struck by parts propelled by a released spring force.

Make sure to wear all necessary protective equipment.

Follow the recommended procedure and use all recommended tooling to release the spring force.

12. Remove piston (60) and spring (62).
13. Remove key (61).

Disassembly of the Final Drive



Illustration 23

g01406376

1. Use a suitable lifting device to position the final drive on Tooling (B), as shown. The weight of the final drive is approximately 200 kg (441 lb).
 2. Remove plugs (63). Remove the O-ring seals from plugs (63). Check the O-ring seals for wear or for damage. Replace the O-ring seals, if necessary.
 3. Remove bolts (65). Remove cover (64).
-



Illustration 24

g01406386

4. Raise the temperature of bolts (66) in order to loosen the thread sealant.
5. Remove bolts (66) and plate (67).



Illustration 25

g01406397

6. Remove sun gear (68).

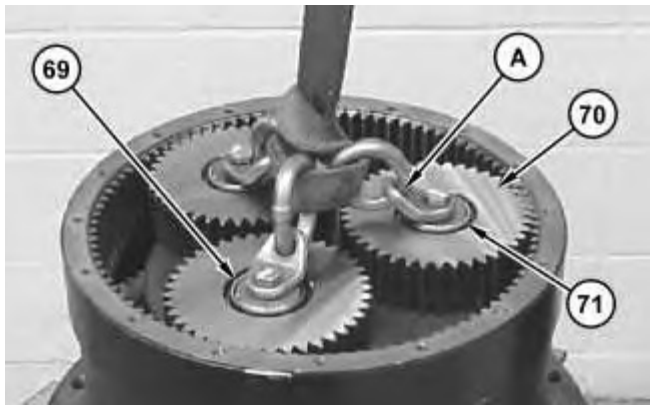

Illustration 26

g01406400

7. Attach Tooling (A) and a suitable lifting device to carrier assembly (69). Remove carrier assembly (69), planetary gear assembly (70), and bearing assembly (71) as a unit.

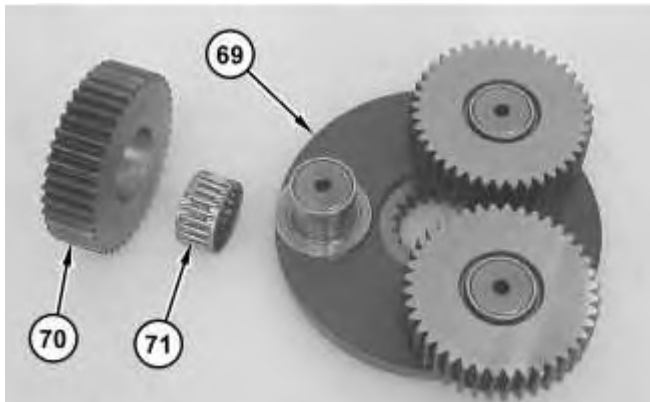

Illustration 27

g01406789

8. Remove planetary gear (70) and bearing assembly (71) from carrier assembly (69). Remove the remaining planetary gears (70) and bearings (71).

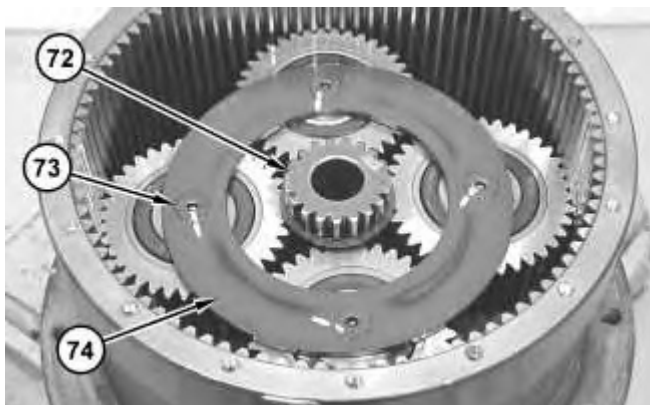

Illustration 28

g01406822

9. Remove sun gear (72).

10. Raise the temperature of bolts (73) in order to loosen the thread sealant. Remove bolts (73). Remove plate (74).



Illustration 29

g01406850

11. Remove retaining ring (75) from sun gear (72). Check retaining ring (75) for wear or for damage. Replace retaining ring (75), if necessary.



Illustration 30

g01406853

12. Remove planetary gear (76).
-

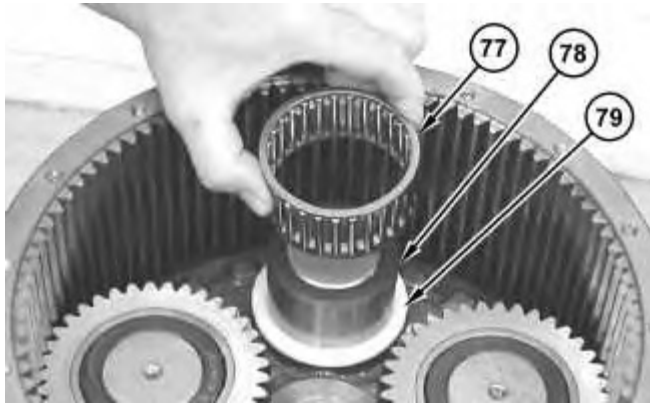

Illustration 31

g01406875

13. Remove bearing (77), race (78), and thrust washer (79).
14. Repeat Steps 12 and 13 in order to remove the remaining planetary gear assemblies.

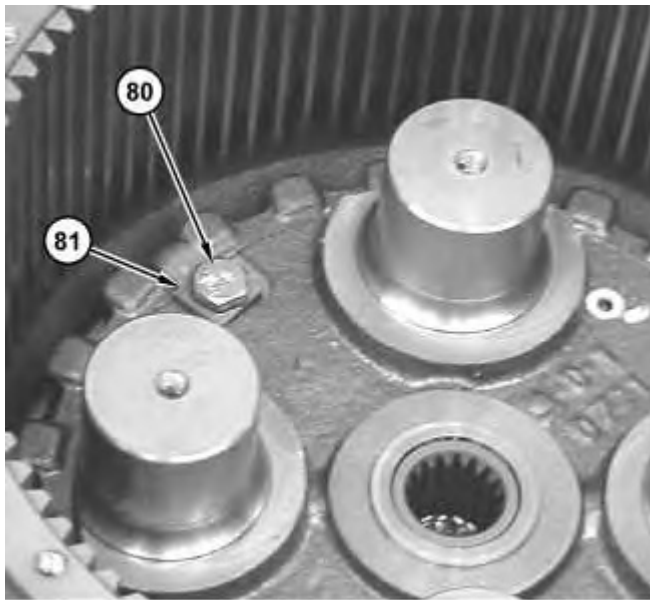

Illustration 32

g01406882

15. Remove bolt (80) and plate (81).



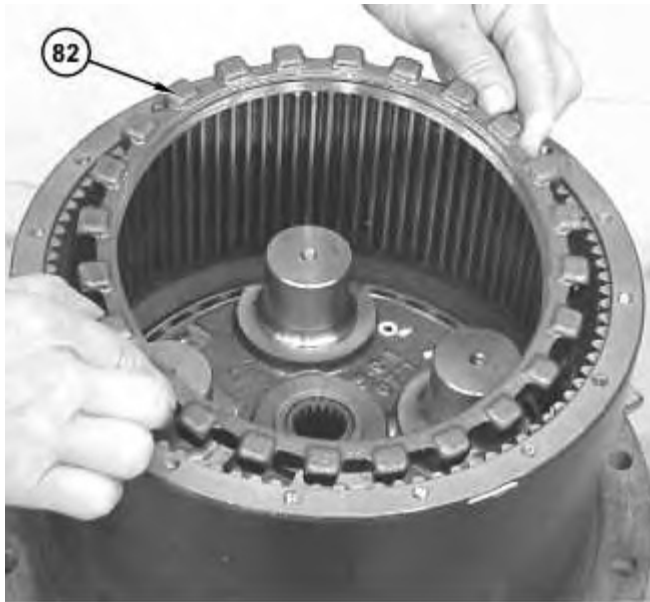

Illustration 34

16. Use Tooling (H) to remove nut (82).

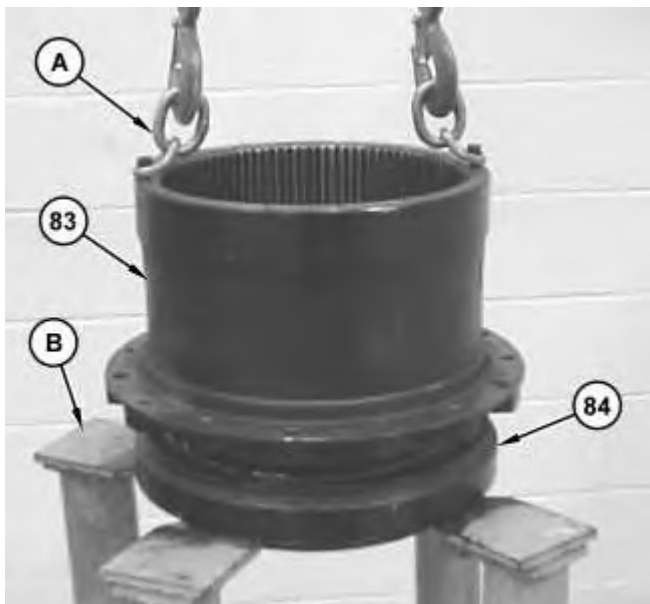

Illustration 35

17. Install Tooling (A) and a suitable lifting device to housing (83). The weight of housing (83) is approximately 35 kg (77 lb).
 18. Remove housing (83) from body assembly (84).
-



Illustration 36

g01406912

19. Remove Duo-Cone Seal Gp seal (85) from the body assembly. Remove the Duo-Cone Seal Gp seal from the housing.

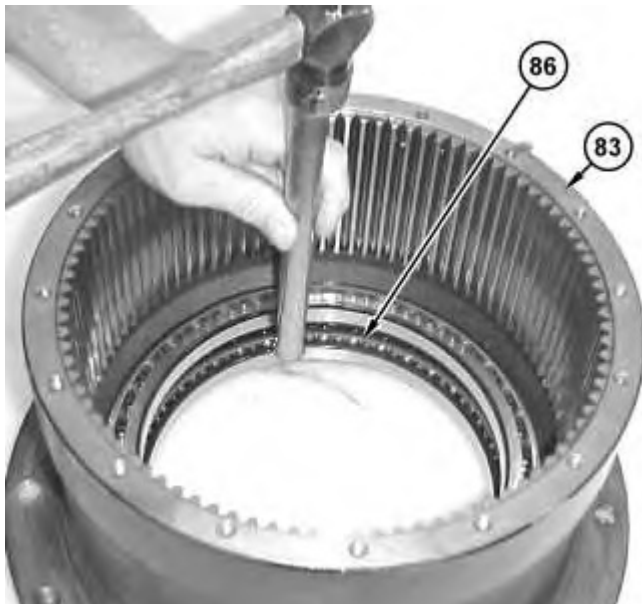

Illustration 37

g01407100

20. Remove both bearings (86) from housing (83).
-

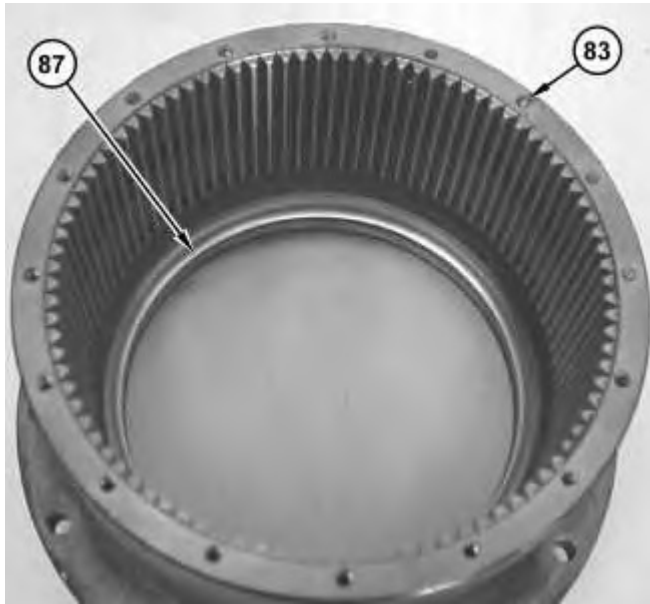

Illustration 38

g01407089

21. Remove both bearings (87) from housing (83).

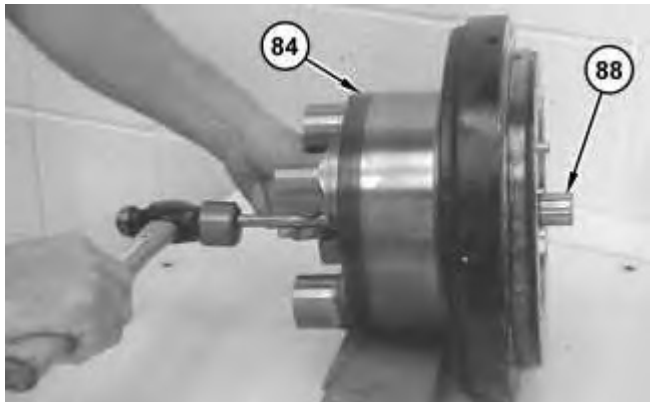
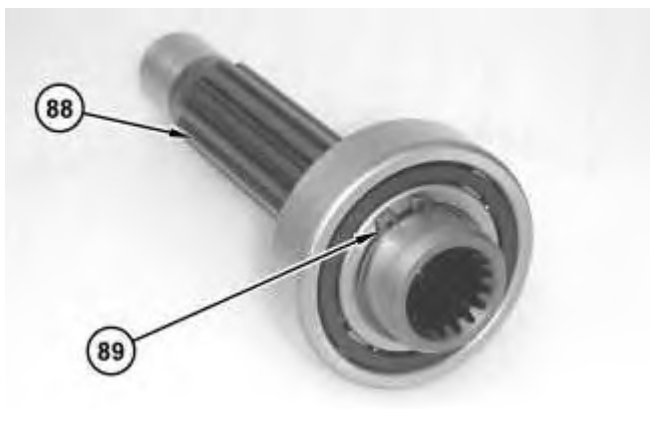

Illustration 39

g01407115

22. Position body assembly (84) horizontally. Remove shaft assembly (88), the bearing, and the retaining ring.



23. Use Tooling (G) to remove retaining ring (89) from shaft assembly (88).

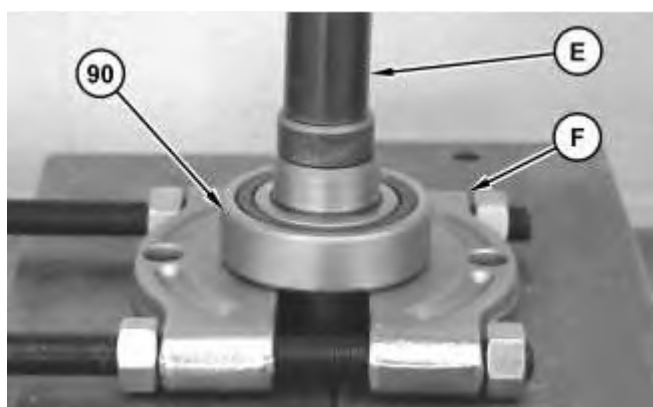

Illustration 41

24. Use Tooling (E), Tooling (F), and a suitable press to remove bearing (90).



Illustration 42

25. Remove lip seal (91) from the body assembly.

[Previous Screen](#)

Product: EXCAVATOR

Model: 314C EXCAVATOR SNY

Configuration: 314C CR Excavator SNY00001-UP (MACHINE) POWERED BY 3064 Engine

Disassembly and Assembly

314C Excavator Excavator Systems

Media Number -REN6613-05

Publication Date -01/03/2017

Date Updated -13/03/2017

i07269885

Final Drive and Travel Motor - Assemble

SMCS - 4050-016; 4351-016

S/N - KJA277-UP

S/N - PCA1658-UP

S/N - SNY499-UP

Assembly Procedure

Table 1

Required Tools			
Tool	Part Number	Part Description	Qty
A	138-7573	Link Bracket	3
B	1P-2420	Transmission Repair Stand	1
E	1P-0510	Driver Gp	1
F	8H-0663	Bearing Puller Gp	1
G	1P-1863	Retaining Ring Pliers	1
H	9U-7346	Spanner Wrench As	1
K	1U-7558	Mounting Adapter Gp ⁽¹⁾	1
L	-	Loctite 271	-
M	-	Loctite High Flex GM	-
N	169-0503	Installation Kit	1
P	1U-6434	Duo-Cone Seal Installer As	1

Q	4C-3761	C-Clamp	2
R	FT-2766	Rolling Torque Bar	1
S	-	Loctite 272	-

⁽¹⁾ The bent plates for the mounting adapter may be modified so that the mounting adapter can be assembled to the housing.

Assembly Procedure for the Final Drive

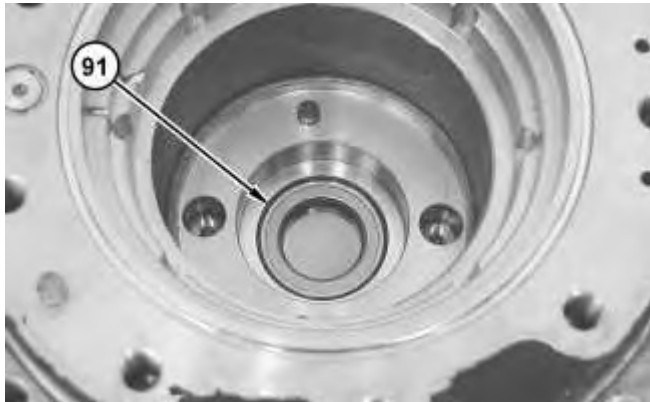

Illustration 1

g01407166

1. Use Tooling (E) to install lip seal (91) into the body assembly.

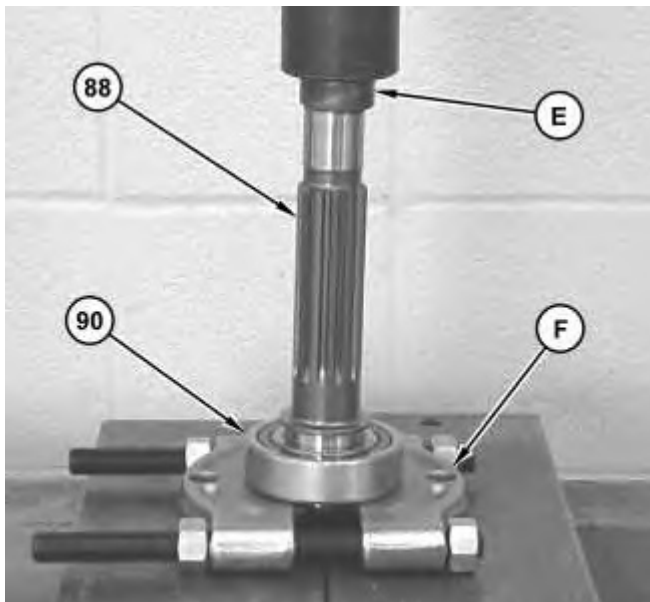

Illustration 2

g01407561

2. Use Tooling (E), Tooling (F), and a suitable press to install bearing assembly (90) onto shaft assembly (88).



Suggest:

If the above button click is invalid.

Please download this document

first, and then click the above link

to download the complete manual.

Thank you so much for reading

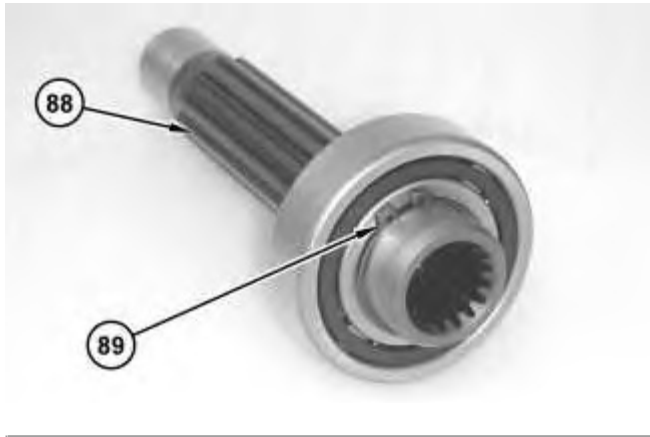

Illustration 3

g01407144

3. Use Tooling (G) to install retaining ring (89) on shaft assembly (88).

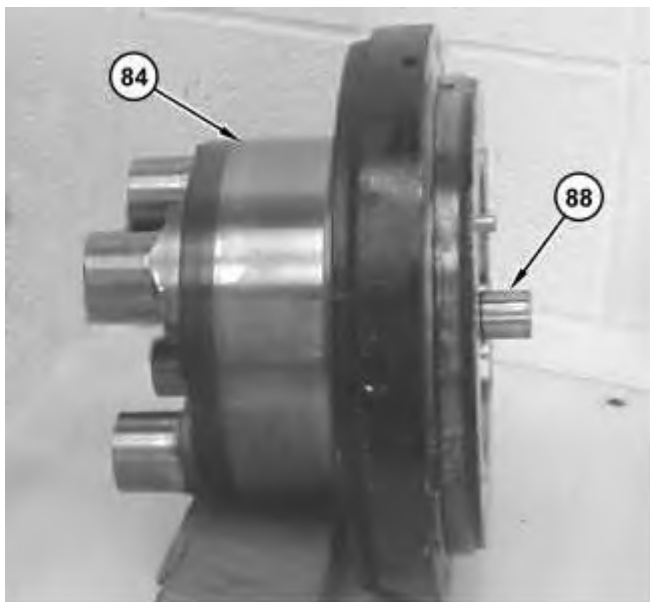

Illustration 4

g01407580

4. Use a suitable soft faced hammer to install shaft assembly (88) into body assembly (84).



Illustration 5

g01407608

<https://www.ebooklibonline.com>

Hello dear friend!

Thank you very much for reading.

Enter the link into your browser.

The full manual is available for immediate download.

<https://www.ebooklibonline.com>