



# Service Repair Manual

## **Models**

313D2 LGP Excavator

---

[Previous Screen](#)

Product: EXCAVATOR

Model: 313D2 LGP EXCAVATOR RKN

Configuration: 313D2 LGP Excavator RKN00001-UP (MACHINE) POWERED BY 3054C Engine

## Disassembly and Assembly 313D2 Excavator Machine Systems

Media Number -UENR3323-06

Publication Date -01/06/2018

Date Updated -27/06/2018

i05453130

# Final Drive - Disassemble

SMCS - 4050-015

## Disassembly Procedure

Table 1

Required Tools			
Tool	Part Number	Part Description	Qty
A	1P-2420	Transmission Repair Stand	1
B	439-3938	Link Bracket	2
C	154-6181	Forcing Bolt	1
D	439-3940	Link Bracket	2
E	5F-7366	Forcing Bolt	1
	1P-5546	Crossblock	1
	1U-9889	Crossblock	1
	1P-0520	Driver Group	1
	6V-7888	Puller Leg	2
	1H-3112	Puller Assembly	1
	1P-5551	Adjustable Screw Assembly	1
F	-	Loctite 5127	1

### Start By:

- a. Remove the final drive.

**Note:** Cleanliness is an important factor. Before the disassembly procedure, thoroughly clean the exterior of the component. This action will prevent dirt from entering the internal mechanism.

1. Put an alignment mark across the sections of the final drive for assembly purposes. The parts must be reinstalled in the original locations.



Illustration 1

g00708089

2. Fasten the final drive to Tooling (A), as shown. The combined weight of the final drive and final drive sprocket is approximately 312 kg (688 lb).
3. Remove bolts (1) and the washers that hold the cover in position.

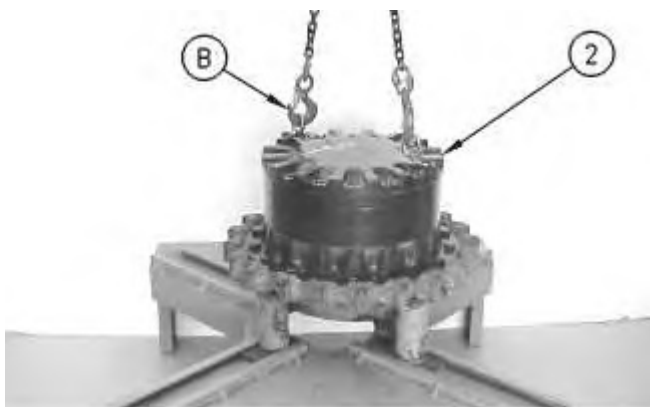

Illustration 2

g00708090

4. Remove the setscrews from cover (2), and fasten Tooling (B) and a suitable lifting device to cover (2), as shown. The weight of cover (2) is approximately 32 kg (70 lb). Remove cover (2).
-

**<https://www.ebooklibonline.com>**

Hello dear friend!

Thank you very much for reading.

Enter the link into your browser.

The full manual is available for immediate download.

**<https://www.ebooklibonline.com>**

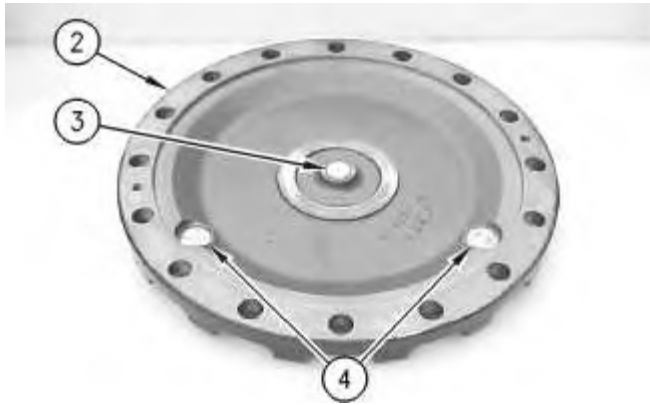

Illustration 3

g00708091

5. Remove thrust plate (3) from cover (2).
6. Remove plugs (4) from cover (2).



Illustration 4

g00708235

7. Remove O-ring seals (5) from both plugs (4) that were in the cover.

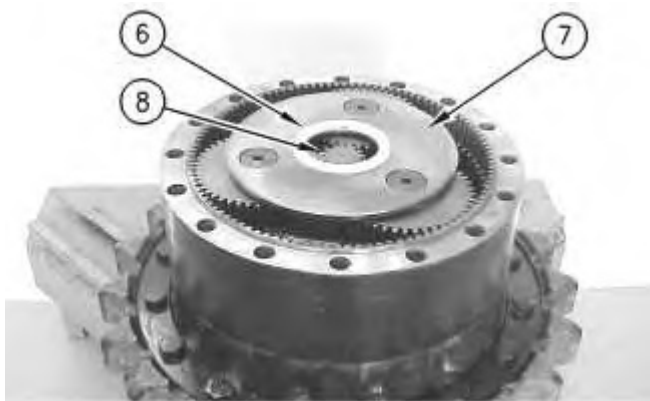

Illustration 5

g00708092

8. Remove spacer (6) from carrier assembly (7).
9. Remove sun gear (8) from carrier assembly (7).

10. Remove carrier assembly (7) by lifting the carrier assembly straight up. The weight of carrier assembly (7) is approximately 14 kg (30 lb).

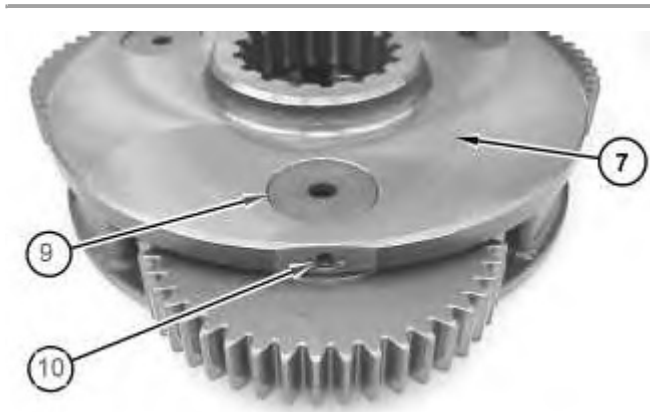

Illustration 6

g01304883

11. Disassemble carrier assembly (7), as follows.

- a. Drive spring pin (10) into planetary shaft (9) with a hammer and a punch.



Illustration 7

g00708144

- b. Remove planetary shaft (9) with spring pin (10) from the carrier assembly.  
c. Remove spring pin (10) from planetary shaft (9) with a hammer and a punch.

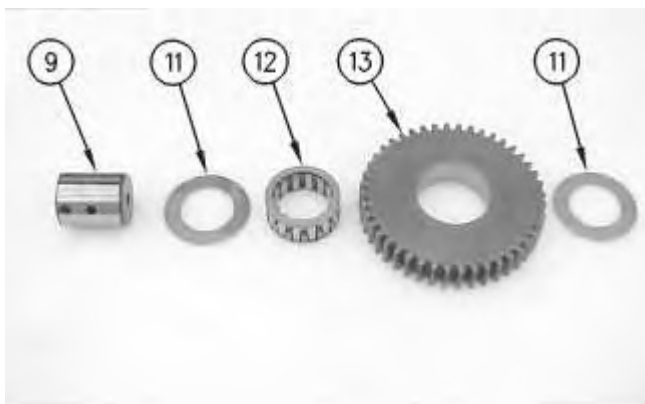

- d. Remove thrust washers (11) and planetary gear (13) from the carrier assembly.
  - e. Remove bearing (12) from planetary gear (13).
12. Repeat Steps 11.a through 11.e in order to remove the remaining planetary gears from the carrier assembly.



Illustration 9

g00708162

13. Remove sun gear (14) from carrier assembly (15).

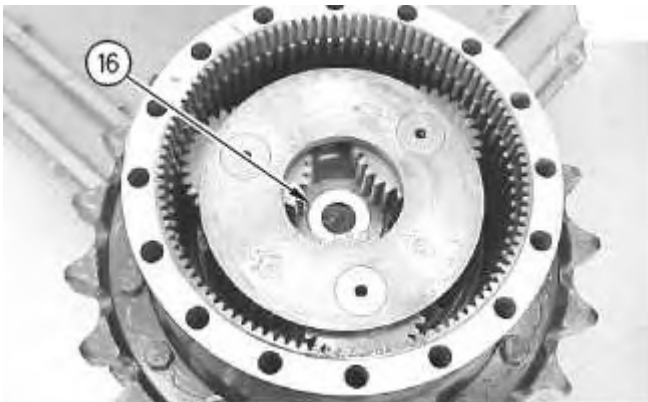
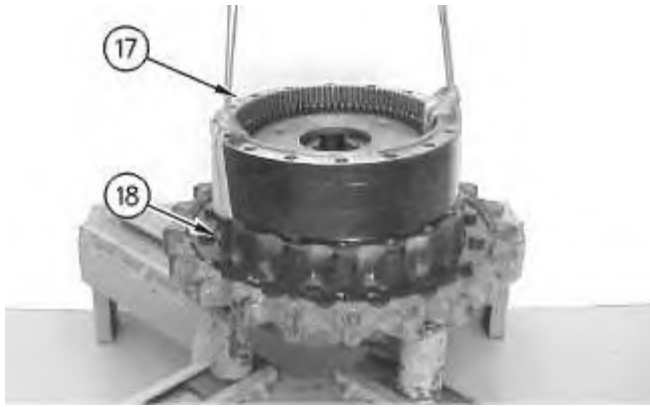

Illustration 10

g00708325

14. Remove spacer (16).
-



---

Illustration 11

g00708184

**Note:** It will be necessary to pry ring gears (17) away from main housing (18) in order to install the lifting slings.

15. Fasten a suitable lifting device to ring gears (17), as shown. Remove the ring gears from main housing (18). The weight of ring gears (17) is approximately 45 kg (100 lb).



---

Illustration 12

g00708360

16. Use a screwdriver or a chisel in order to separate two ring gears (17).

**Note:** Two ring gears (17) are held together with Tooling (F). It may be necessary to heat ring gears (17) in order to soften the sealant. Do not heat over 135 °C (275 °F) for more than thirty minutes.

---

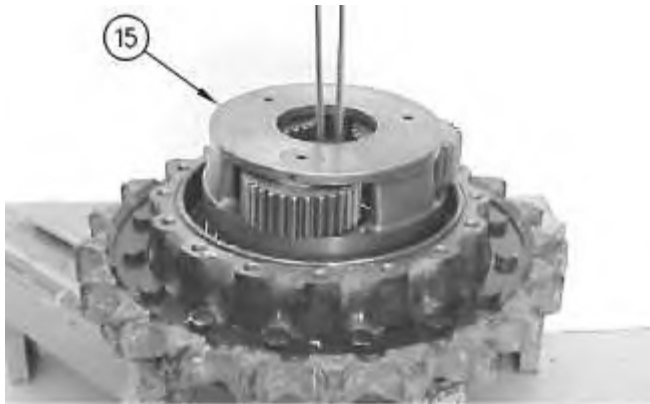

Illustration 13

g00708172

17. Position a 12.7 mm (0.50 inch) shackle under carrier assembly (15).
18. Fasten a suitable lifting device to the shackle.
19. Slowly lift carrier assembly (15) from the final drive. The weight of carrier assembly (15) is approximately 39 kg (85 lb).
20. Disassemble carrier assembly (15), as follows.



Illustration 14

g00708175

- a. Drive spring pin (20) into planetary shaft (19) with a hammer and a punch.



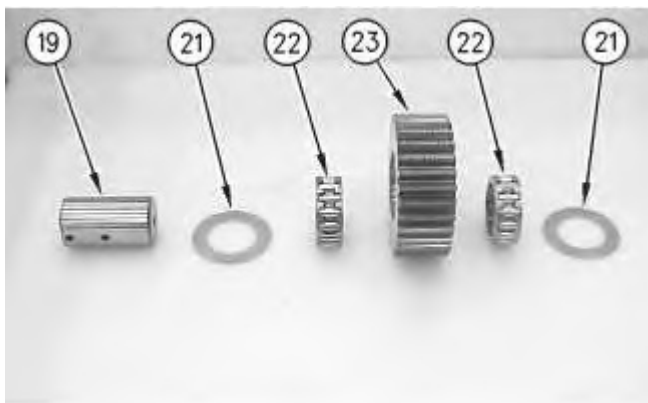

Illustration 16

- b. Remove planetary shaft (19) with spring pin (20) from the carrier assembly.
  - c. Remove spring pin (20) from planetary shaft (19) with a hammer and a punch.
  - d. Remove thrust washers (21) and planetary gear (23) from the carrier assembly.
  - e. Remove bearings (22) from planetary gear (23).
21. Repeat Steps 20.a through 20.e in order to remove the remaining planetary gears from the carrier.

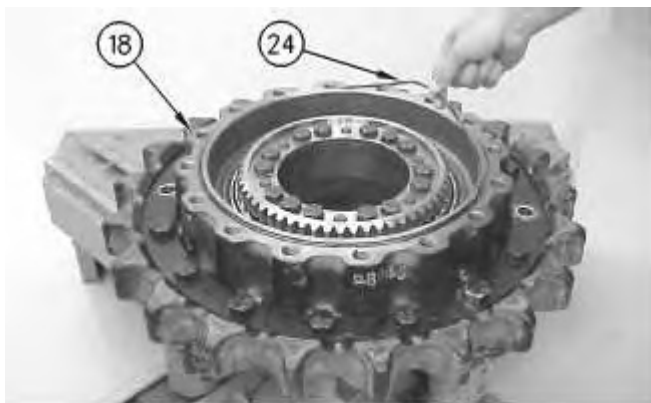

Illustration 17

22. Remove O-ring seal (24) from main housing (18).
-



Illustration 18

g00708187

23. Remove bolts (25) from gear (26).

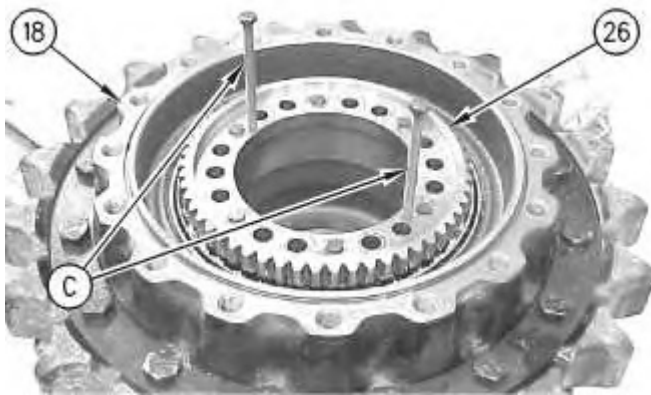

Illustration 19

g00708202

24. Use Tooling (C) in order to remove gear (26) from main housing (18).

**Note:** The motor housing will separate from main housing (18) once gear (26) is removed. Make sure that the motor housing is supported.



Illustration 20

g00708211

25. Remove shims (27) from the main housing.

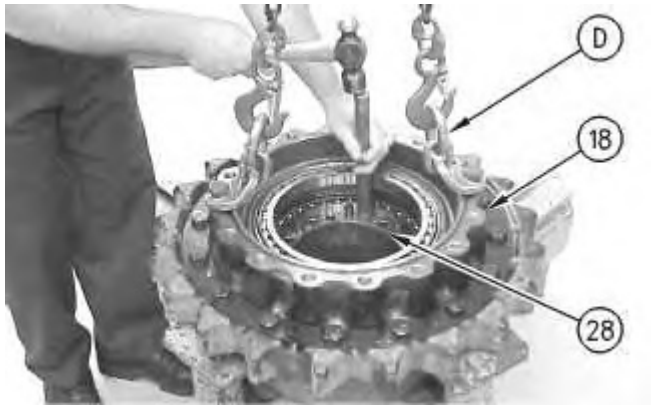

Illustration 21

g00708212

26. Fasten Tooling (D) and a suitable lifting device to main housing (18), as shown.
27. Use a hammer and a punch in order to separate main housing (18) and the final drive sprocket from motor housing (28). The combined weight of main housing (18) and the final drive sprocket is approximately 82 kg (180 lb).

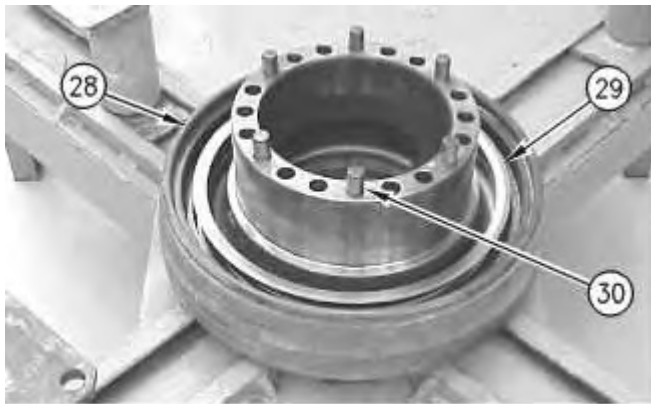

Illustration 22

g00708214

28. Remove Duo-Cone seal (29) from motor housing (28).
29. Remove alignment pins (30).

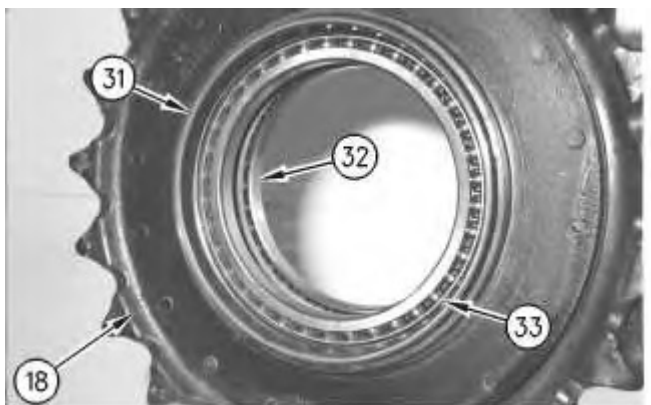

Illustration 23

g00708215

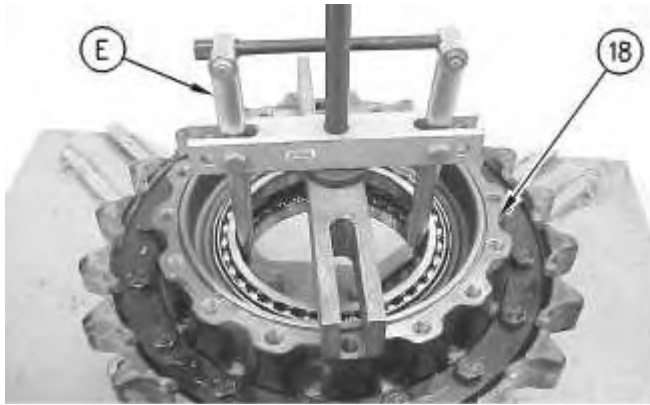

Illustration 24

g00708216

30. Remove Duo-Cone seal (31) from main housing (18).
31. Use Tooling (E) in order to remove bearings (32) and (33) from the main housing.
32. If necessary, remove the final drive sprocket from the main housing.
33. Refer to Disassembly and Assembly, "Final Drive Sprocket - Remove and Install".

[Previous Screen](#)

Product: EXCAVATOR

Model: 313D2 LGP EXCAVATOR RKN

Configuration: 313D2 LGP Excavator RKN00001-UP (MACHINE) POWERED BY 3054C Engine

## Disassembly and Assembly 313D2 Excavator Machine Systems

Media Number -UENR3323-06

Publication Date -01/06/2018

Date Updated -27/06/2018

i07255515

# Final Drive - Disassemble

SMCS - 4050-015

## Disassembly Procedure

Table 1

Required Tools			
Tool	Part Number	Part Description	Qty
A	477-3191	M14x2x18 mm Lifting Eye Assembly	2
B	1P-2420	Transmission Repair Stand	1
C	6V-8214	M6x20mm Bolt	2
	9X-8267	M6 Washer	2
D	8H-0663	Bearing Puller Assembly	1
E	422-5474	M16x2x24mm Lifting Eye Assembly	2
F	439-3938	Link Bracket	3
G	1U-9889	Crossblock	1

### Start By:

- a. Remove the final drive and the travel motor assembly.

---

### NOTICE

Care must be taken to ensure that fluids are contained during performance of inspection, maintenance, testing, adjusting, and repair of the product. Be prepared to collect the fluid with suitable containers

**before opening any compartment or disassembling any component containing fluids.**

**Refer to Special Publication, NENG2500, "Dealer Service Tool Catalog" for tools and supplies suitable to collect and contain fluids on Cat<sup>®</sup> products.**

**Dispose of all fluids according to local regulations and mandates.**

---



**Personal injury can result from hydraulic oil pressure and hot oil.**

**Hydraulic oil pressure can remain in the hydraulic system after the engine has been stopped. Serious injury can be caused if this pressure is not released before any service is done on the hydraulic system.**

**Make sure all of the work tools have been lowered to the ground, and the oil is cool before removing any components or lines. Remove the oil filler cap only when the engine is stopped, and the filler cap is cool enough to touch with your bare hand.**

---

1. Thoroughly clean the outside of the final drive and travel motor prior to disassembly.
2. Remove the sprocket from the final drive and the travel motor assembly. The weight of the sprocket is approximately 36 kg (79 lb).

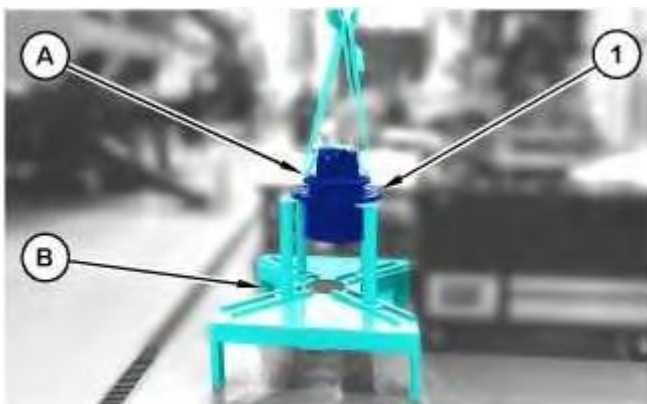

Illustration 1

g06260984

3. Use Tooling (A) and a suitable lifting device to position final drive assembly (1) onto Tooling (B). The weight of final drive assembly (1) is approximately 281 kg (620 lb).

## **WARNING**

**Personal injury can result from being struck by parts propelled by a released spring force.**

**Make sure to wear all necessary protective equipment.**

**Follow the recommended procedure and use all recommended tooling to release the spring force.**

---



Illustration 2

g06261012

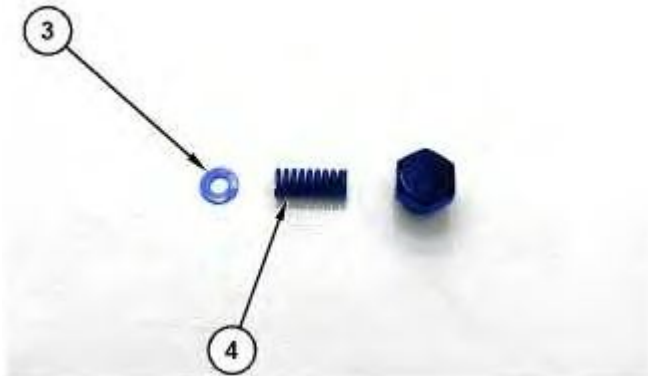

Illustration 3

g06261017

4. Remove plug (2), spring (4), seat (3), and the O-ring seal.

## **WARNING**

**Personal injury can result from being struck by parts propelled by a released spring force.**

**Make sure to wear all necessary protective equipment.**

**Follow the recommended procedure and use all recommended tooling to release the spring force.**

---



Illustration 4

g06261029

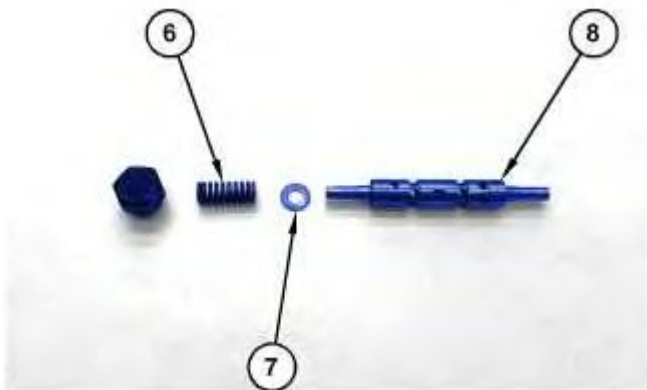

Illustration 5

g06261032

5. Remove plug (5), spring (6), seat (7), stem assembly (8), and the O-ring seal.

**! WARNING**

**Personal injury can result from being struck by parts propelled by a released spring force.**

**Make sure to wear all necessary protective equipment.**

**Follow the recommended procedure and use all recommended tooling to release the spring force.**

---

---



Illustration 6

g06261260

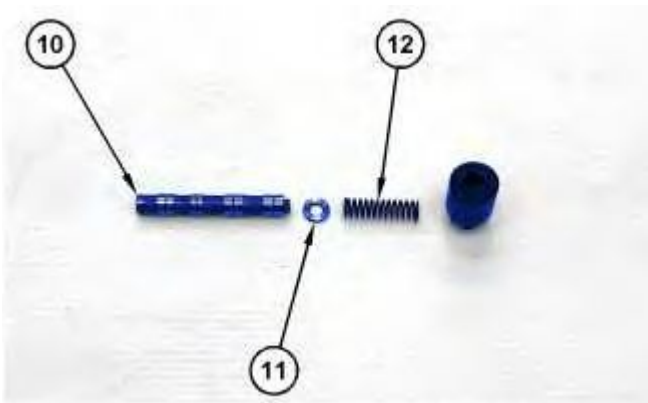

Illustration 7

g06261275

6. Remove plug (9), spring (12), seat (11), spool (10), and the O-ring seal.



Illustration 8

g06261285

7. Remove adapter (13) and the O-ring seal.

 **WARNING**

**Personal injury can result from being struck by parts propelled by a released spring force.**

**Make sure to wear all necessary protective equipment.**

**Follow the recommended procedure and use all recommended tooling to release the spring force.**

---



Illustration 9

g06261336

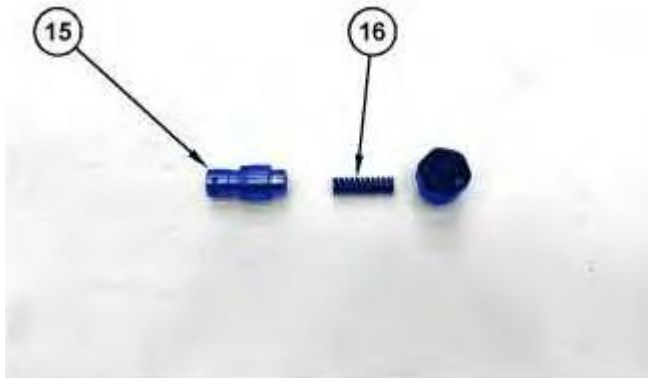

Illustration 10

g06261344

8. Remove plug (14), spring (16), valve (15), and the O-ring seal.

 **WARNING**

**Personal injury can result from being struck by parts propelled by a released spring force.**

**Make sure to wear all necessary protective equipment.**

**Follow the recommended procedure and use all recommended tooling to release the spring force.**



Illustration 11

g06261519

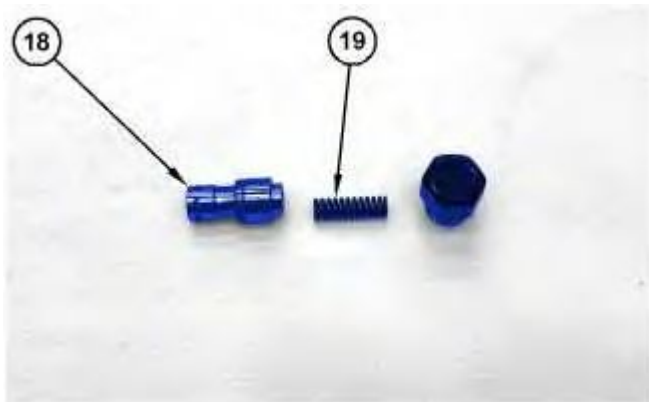

Illustration 12

g06261532

9. Remove plug (17), spring (19), valve (18), and the O-ring seal.

 **WARNING**

**Personal injury can result from being struck by parts propelled by a released spring force.**

**Make sure to wear all necessary protective equipment.**

**Follow the recommended procedure and use all recommended tooling to release the spring force.**

---

---

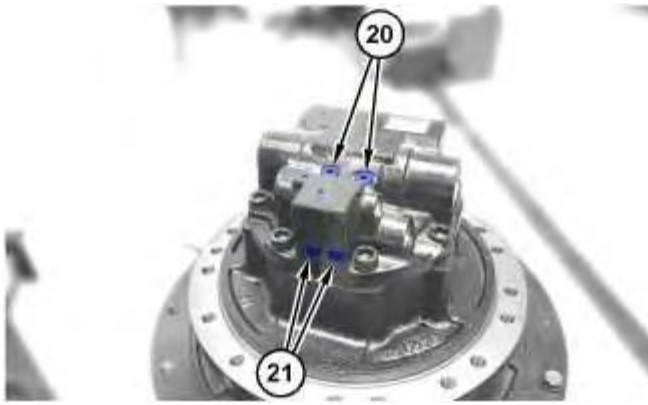

Illustration 13

g06261538

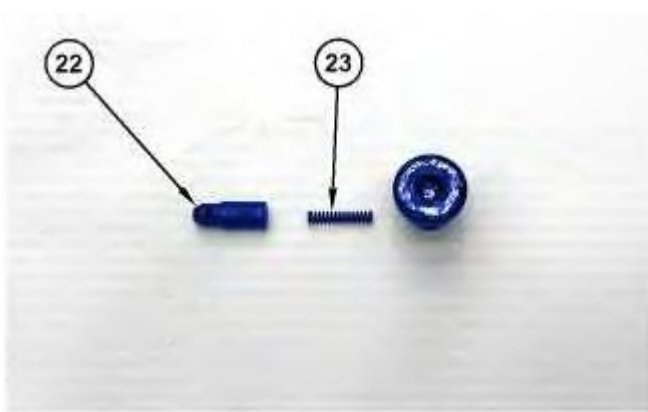

Illustration 14

g06261539

10. Remove plugs (20) and the O-ring seals.
11. Remove plugs (21), springs (23), valves (22), and the O-ring seals.

 **WARNING**

**Personal injury can result from being struck by parts propelled by a released spring force.**

**Make sure to wear all necessary protective equipment.**

**Follow the recommended procedure and use all recommended tooling to release the spring force.**

---

---

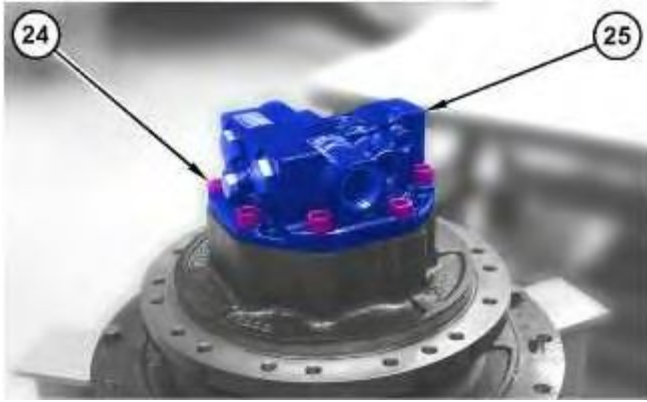

Illustration 15

g06261563

12. Remove bolts (24) and valve body (25).



Illustration 16

g06263306

Port plate (28) may still be adhered to the barrel assembly.

13. Remove springs (26), port plate (28), and O-ring seals (27).



Illustration 17

g06261586

14. Remove bearing (29).

15. Remove O-ring seal (30).



Illustration 18

g06261622

16. Use Tooling (C) and suitable prying devices to remove piston assembly (31).

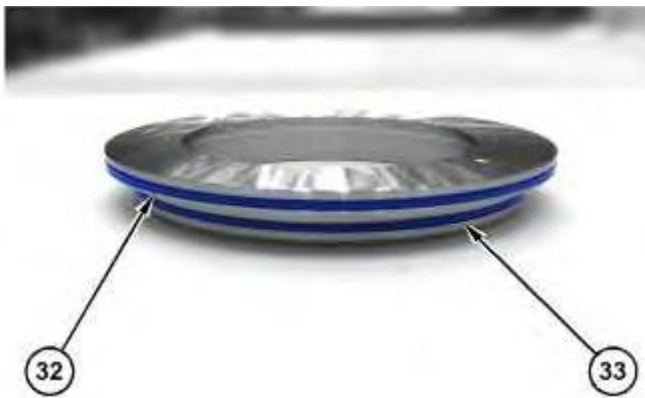

Illustration 19

g06261625

17. Remove O-ring seal (32) and O-ring seal (33).



Illustration 20

g06261647

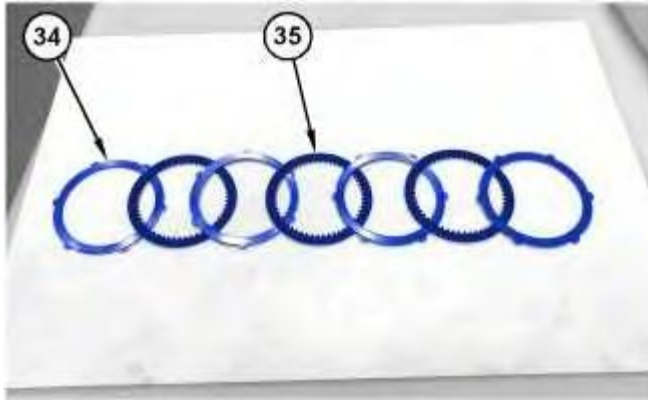

Illustration 21

g06261665

18. Remove separator plates (34) and friction plates (35). Note the alternating order of separator plates (34) and friction plates (35) for assembly purposes.

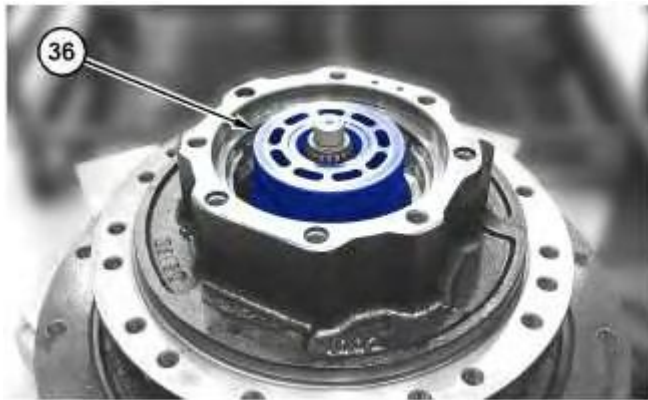

Illustration 22

g06261896

19. Remove barrel assembly (36). Do not allow the components of barrel assembly (36) to come apart while you remove barrel assembly (36). The components of barrel assembly (36) must be reinstalled in the original positions.



Illustration 23

g06261908

20. Remove piston assemblies (37) and retainer (38).

**Note:** Mark the component locations for assembly purposes before you disassemble the barrel assembly.

**! WARNING**

**Personal injury can result from being struck by parts propelled by a released spring force.**

**Make sure to wear all necessary protective equipment.**

**Follow the recommended procedure and use all recommended tooling to release the spring force.**



Illustration 24

g06261915

21. Remove guide (39).

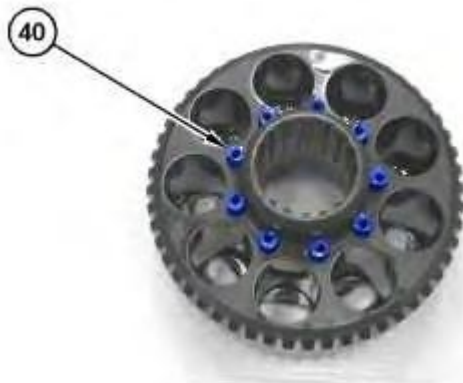

Illustration 25

g06261922

22. Remove springs (40).



Illustration 26

g06261927

23. Put location marks on swashplate (41) for assembly purposes. Remove swashplate (41).

**! WARNING**

**Personal injury can result from being struck by parts propelled by a released spring force.**

**Make sure to wear all necessary protective equipment.**

**Follow the recommended procedure and use all recommended tooling to release the spring force.**

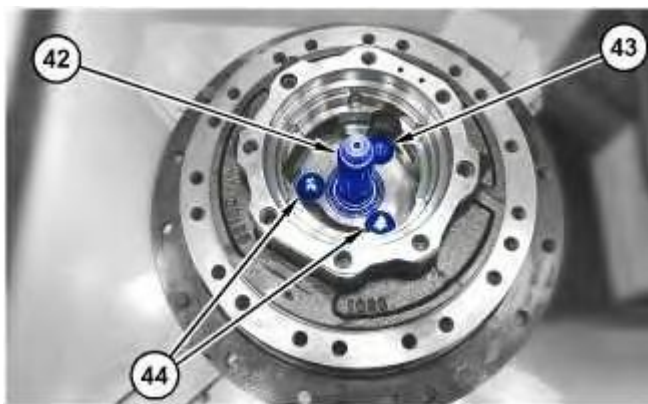

Illustration 27

g06261980



**Suggest:**

**If the above button click is invalid.**

**Please download this document**

**first, and then click the above link**

**to download the complete manual.**

**Thank you so much for reading**



Illustration 28

g06261983

24. Remove shaft assembly (42), keys (44), piston (43), and spring (45).

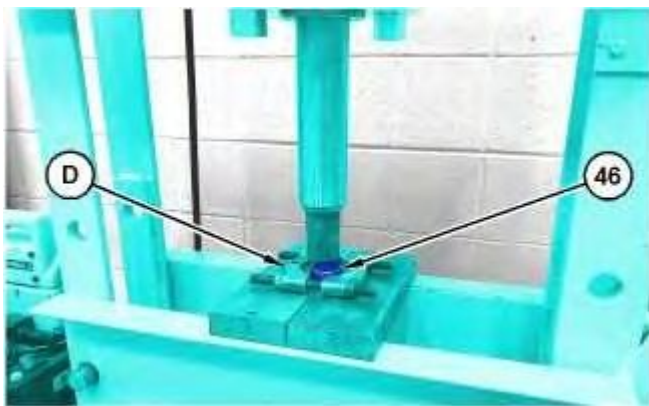

Illustration 29

g06261987

25. Use a suitable press and Tooling (D) to remove bearing (46) off the shaft assembly.

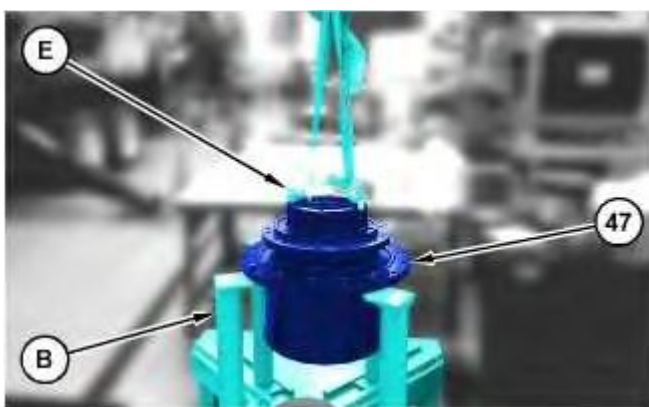

Illustration 30

g06262009

**<https://www.ebooklibonline.com>**

Hello dear friend!

Thank you very much for reading.

Enter the link into your browser.

The full manual is available for immediate download.

**<https://www.ebooklibonline.com>**