



Service Repair Manual

Models

313D2 LGP Excavator

[Previous Screen](#)

Product: EXCAVATOR

Model: 313D2 LGP EXCAVATOR GAJ

Configuration: 313D2 LGP Excavator GAJ00001-UP (MACHINE) POWERED BY 3054C Engine

Disassembly and Assembly

313D2 Excavator Machine Systems

Media Number -UENR3323-06

Publication Date -01/06/2018

Date Updated -27/06/2018

i05533465

Main Hydraulic Pump - Assemble

SMCS - 5070-016

Assembly Procedure

Table 1

Required Tools			
Tool	Part Number	Part Description	Qty
A	1U-5750	Engine Stand	1
B	1P-1861	Retaining Ring Pliers	1
C	1P-1862	Pliers	1
D	-	Loctite 271	-

Note: If a failure occurs, an accurate diagnosis of the cause can prevent a recurrence. Information is available to analyze failures for piston pumps and motors. Refer to Special Publication, SEBD0641, "Analyzing Axial Piston Pump and Motor Failures".

Note: Inspect all parts. If any parts are worn or damaged use new parts for replacement. The installation of used parts during reconditioning is acceptable. Reuse and salvage information is available on piston pumps. Refer to Guideline For Reusable Parts and Salvage Operations, SEBF8032, "Piston Pumps and Motors". During reconditioning, correct any conditions that might have caused the original failure.

Note: Check the O-ring seals, the gaskets and the seals for wear or for damage and replace the components, if necessary.

Note: Cleanliness is an important factor. Before assembly, thoroughly clean all parts with cleaning fluid. Allow the parts to air dry. Do not use wiping cloths or rags to dry parts. Lint may be deposited on the parts which may cause problems. Inspect all parts. If any parts are worn or damaged, install new parts. All disassembly and all assembly procedures must be performed on a

clean work surface and in a clean hydraulic area. Keep cleaned parts covered and protected at all times.

Note: Apply a light film of hydraulic oil to all components before assembly.

Assembly Of Port Block

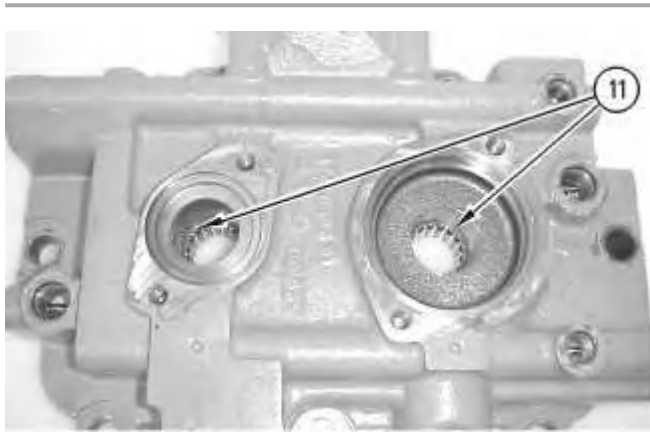


Illustration 1

g00766353

1. Install bearings (11).

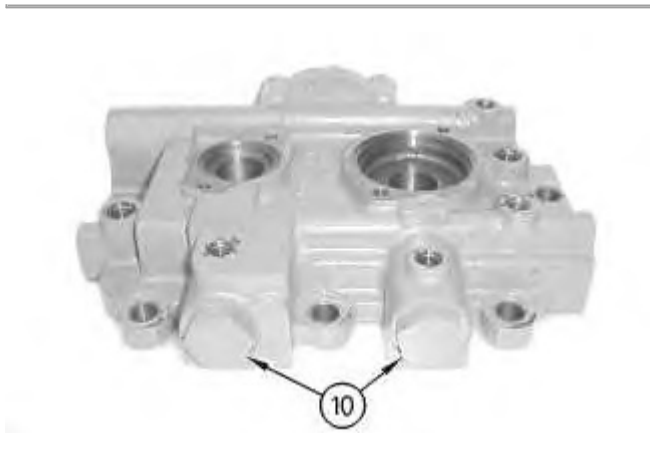


Illustration 2

g00766344

2. Install plugs (10) and the O-ring seals.
-

<https://www.ebooklibonline.com>

Hello dear friend!

Thank you very much for reading.

Enter the link into your browser.

The full manual is available for immediate download.

<https://www.ebooklibonline.com>



Illustration 3

g00766340

3. Install O-ring seals (9).

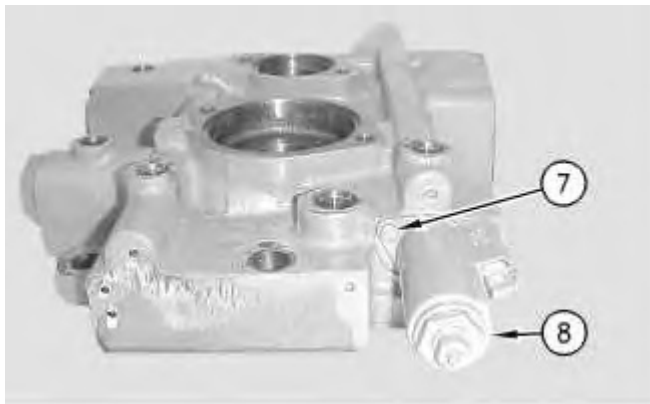


Illustration 4

g00766333

4. Install pressure reducing valve (8) and bolts (7). Tighten bolts (7) to a torque of $9.8 \pm 0.3 \text{ N}\cdot\text{m}$ ($87 \pm 3 \text{ lb in}$).

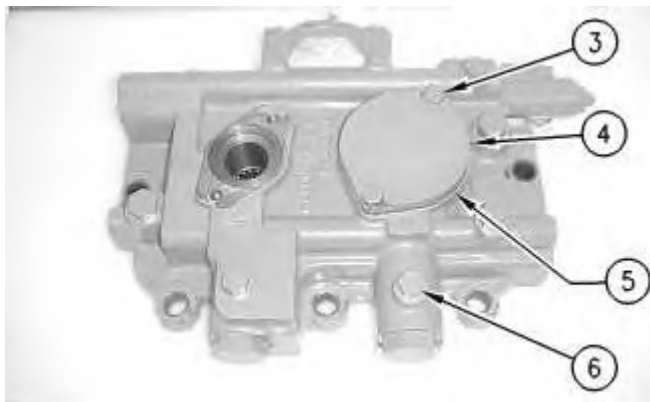


Illustration 5

g00766259

5. Install the O-ring seals and plugs (6).

6. Install O-ring seal (5), cover (4), and bolts (3). Tighten bolts (3) to a torque of 55 ± 10 N·m (41 ± 7 lb ft).

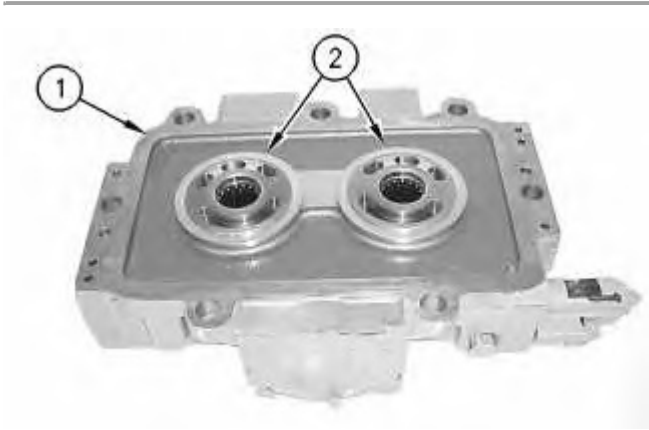


Illustration 6

g00766257

7. Install port plates (2) onto port block (1).

Assembly Of Pump

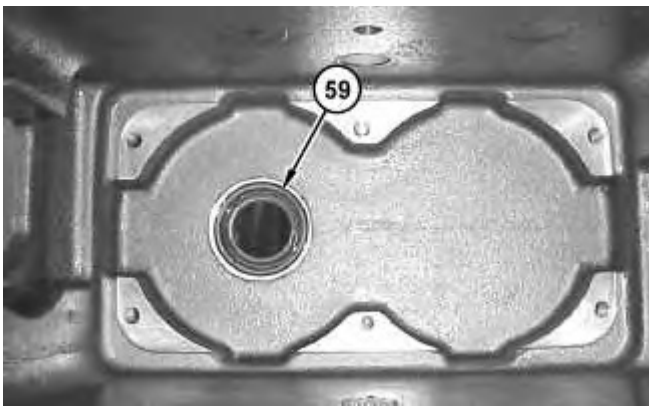
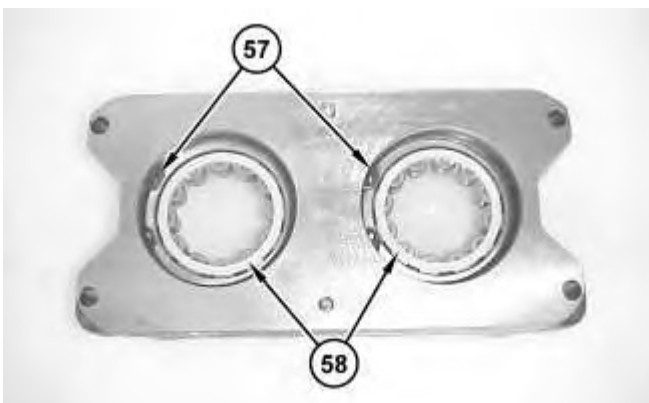


Illustration 7

g01442275

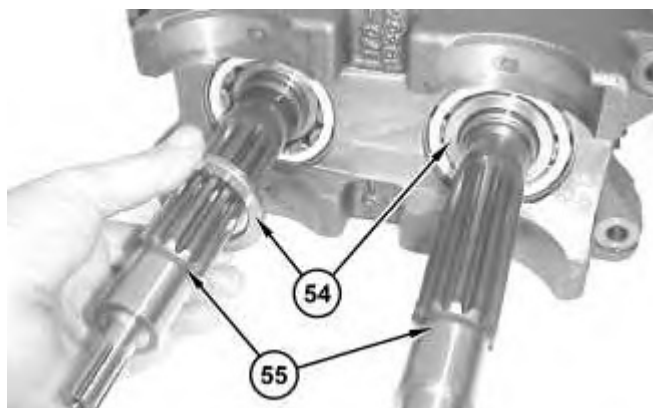
1. Install seal (57) with the seal case into the housing.



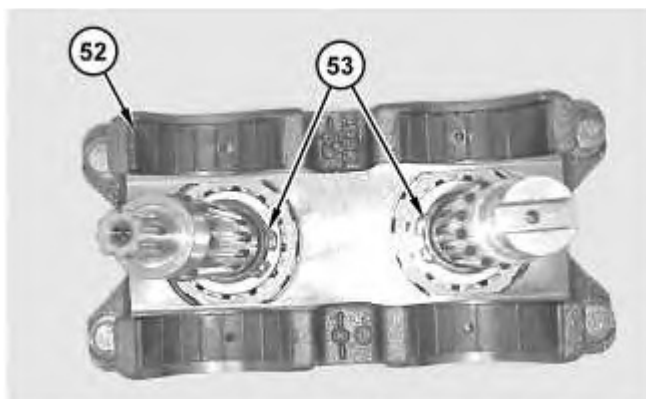
2. Install bearings (58).
3. Use Tooling (B) to install retaining rings (57).



4. Install bearing races (56).



5. Install gear assemblies (55) and spacers (54).



6. Secure the bearings with the dowel pins and install bearings (52). Bearings (52) must be installed in the original locations and orientations that were marked during disassembly.
7. Use Tooling (C) to install retaining rings (53).

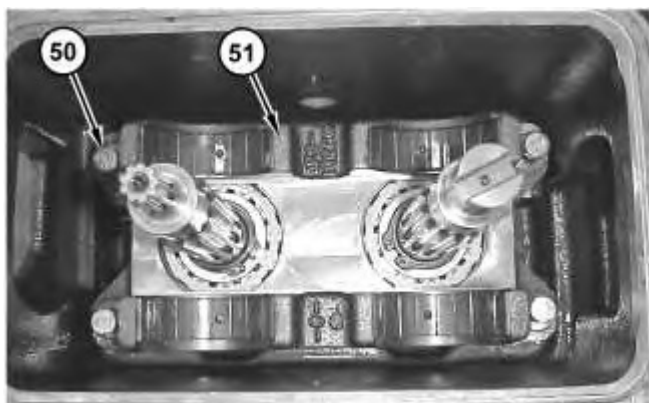


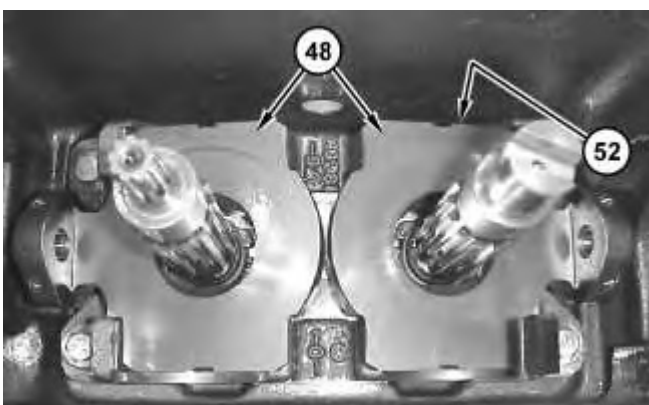
Illustration 12

8. Install cradle (51) and bolts (50). Torque bolts (50) to a torque of 55 ± 10 N·m (41 ± 7 lb ft).



Illustration 13

9. Use Tooling (B) to install retaining ring (49).



- Secure bearings (52) (not shown) with the dowel pins before installing swashplates (48). Install swashplates (48).



Illustration 15

- Install pistons (46) and retainer (45) as a unit into barrel (47). Be sure to install the components in the original locations that were marked during disassembly.

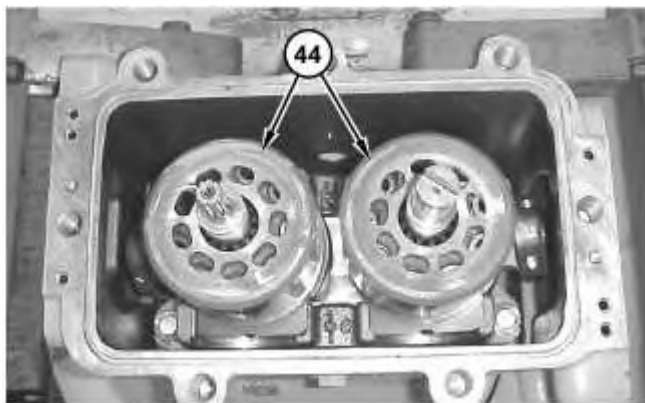
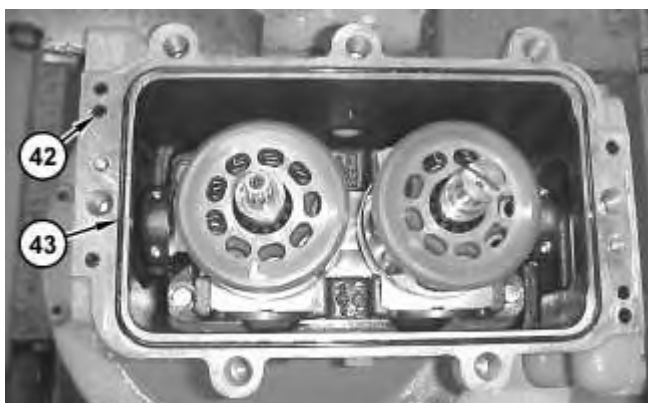


Illustration 16

- Install rotating groups (44) in the original locations.



13. Install O-ring seals (42) and O-ring seal (43).



Illustration 18

14. Position port block (40) and install bolts (41).

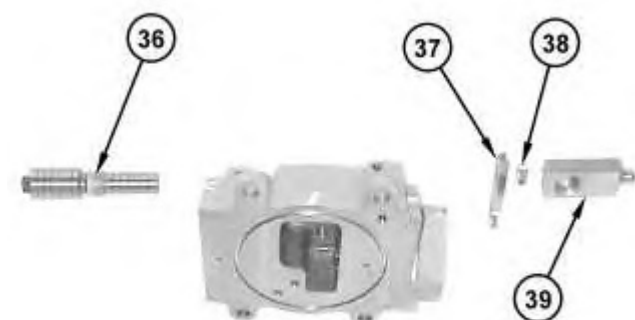


Illustration 19

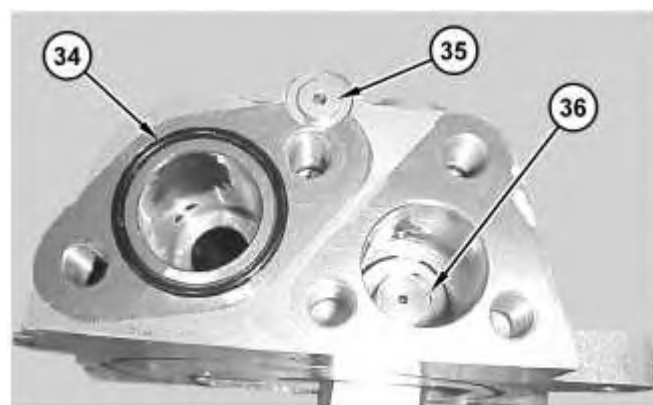


Illustration 20

15. Apply Tooling (D) to the threads of piston (36). Install lever (37), and slide plate (38). Install pin (39). Install piston (36). Tighten piston (36) to a torque of $147 \pm 15 \text{ N}\cdot\text{m}$ ($108 \pm 11 \text{ lb ft}$).
16. Install the O-ring seal and plug (35). Install O-ring seal (34).

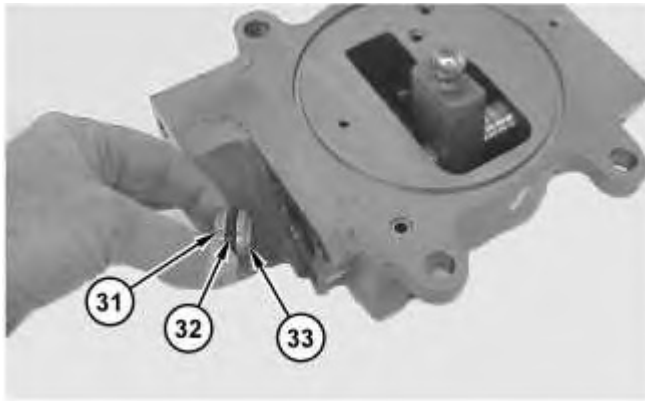


Illustration 21

g01442247

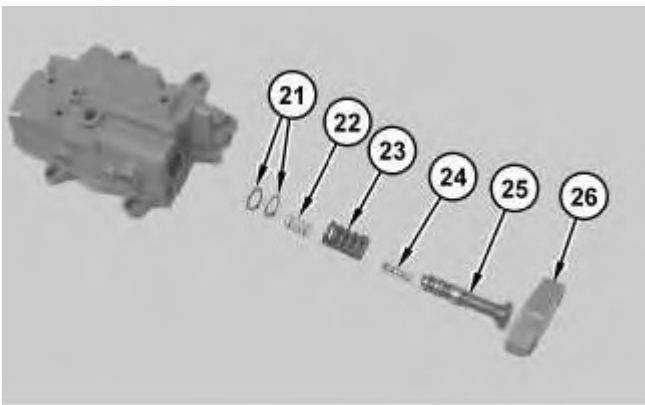
17. Install backup ring (33), O-ring seal (32), and stopper (31). Repeat for the opposite side.

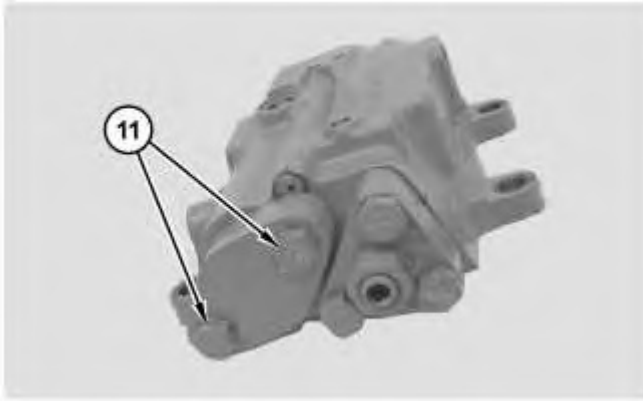


Illustration 22

g01442244

18. Position covers (21) and (22). Install bolts (29) and (30).



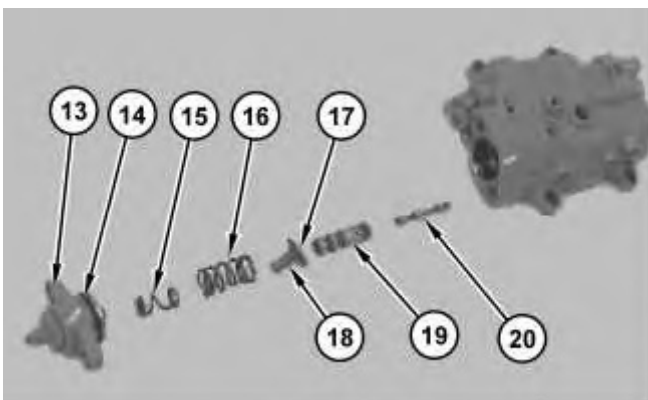


! WARNING

Improper assembly of parts that are spring loaded can cause bodily injury.

To prevent possible injury, follow the established assembly procedure and wear protective equipment.

19. Install shims (21). Install spring (22), spring (23), piston (24), and piston (25). Install cover (26).
20. Install bolts (11).



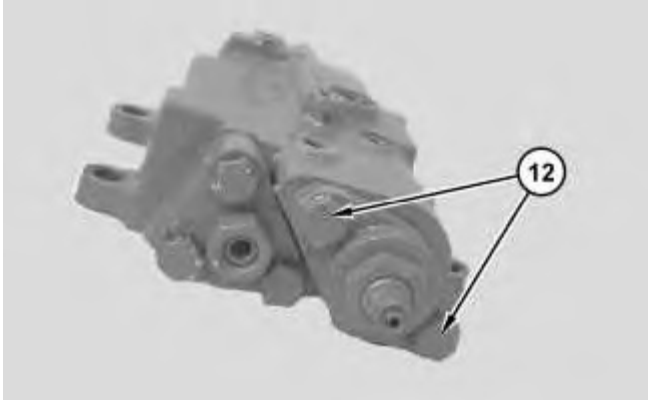


Illustration 26

g01442240

 **WARNING**

Improper assembly of parts that are spring loaded can cause bodily injury.

To prevent possible injury, follow the established assembly procedure and wear protective equipment.

Note: Ensure that the direction of spool (20) is in line with guide (18). Spool (20) has a conical hole on the end in order to locate ball (17).

21. Install spool (20), and sleeve (19). Install guide (18) and ball (17). Install spring (16) and spring (15). Install O-ring seal (14) and cover (13).
22. Install bolts (12).

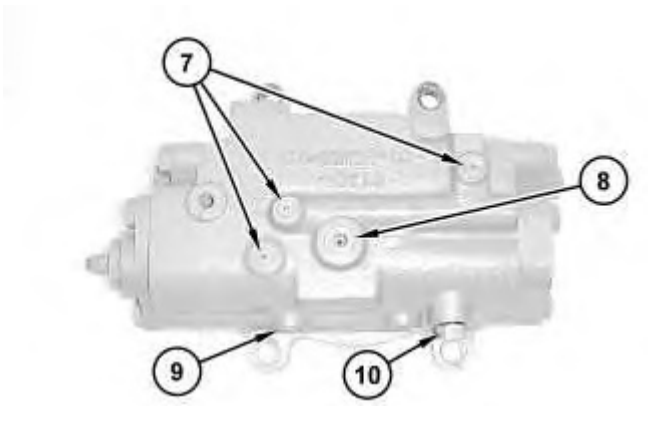


Illustration 27

g01442228

23. Install plugs (7) and the O-ring seals. Install pin (8), plug (10), plug (9), and the O-ring seals.

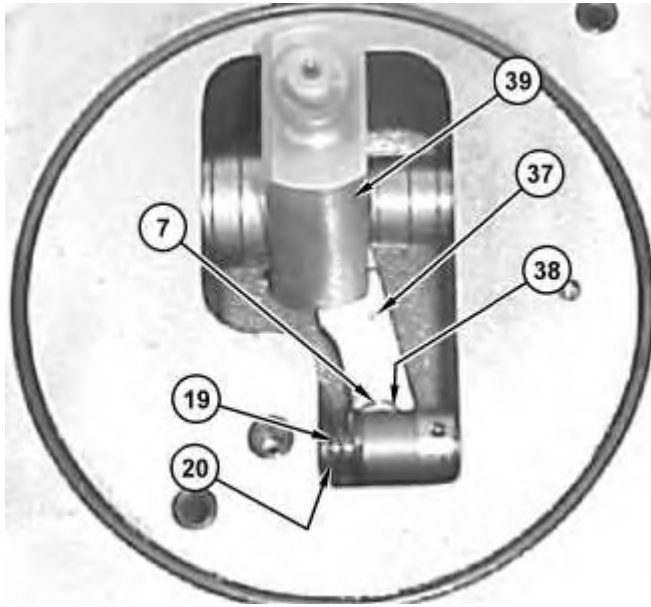


Illustration 28

g01442410

24. Make sure that pin (7) does not bind with lever (37). Make sure that lever (37) does not bind with pin (39). Lever (37) must not bind with slide plate (38) and slide plate (38) must not bind with the assembled sleeve (19) and spool (20).

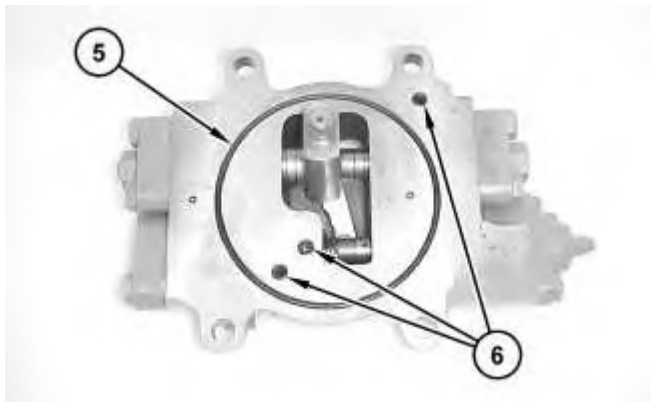
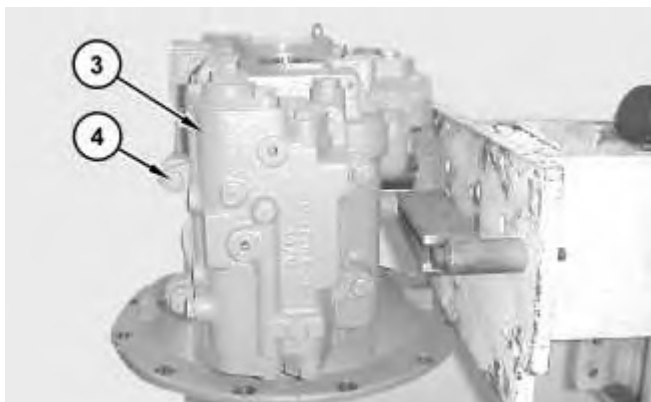


Illustration 29

g01442227

25. Install O-ring seal (5), and O-ring seals (6).



26. Install head group (3) in the original location. Install bolts (4). Repeat this Step for the other head group.

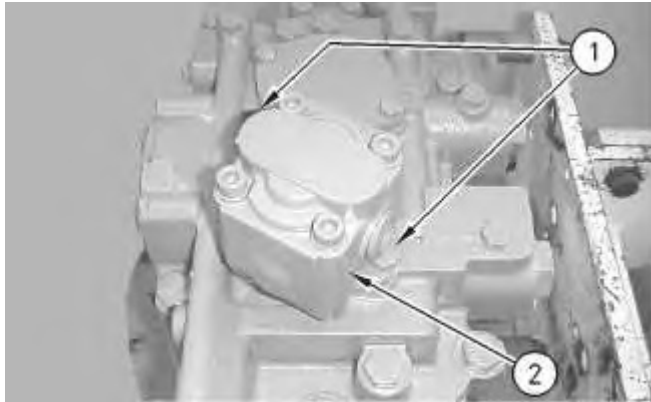


Illustration 31

27. Install gear pump (2) and bolts (1). Tighten bolts (1) to a torque of 44 ± 4 N·m (32 ± 3 lb ft).



Illustration 32

28. Remove the main hydraulic pump from Tooling (A). The weight of the main hydraulic pump is approximately 147 kg (325 lb).

End By:

- a. Install the main hydraulic pump. Refer to Disassembly and Assembly , "Main Hydraulic Pump - Install".

Previous Screen

Product: EXCAVATOR

Model: 313D2 LGP EXCAVATOR GAJ

Configuration: 313D2 LGP Excavator GAJ00001-UP (MACHINE) POWERED BY 3054C Engine

**Disassembly and Assembly
313D2 Excavator Machine Systems**

Media Number -UENR3323-06

Publication Date -01/06/2018

Date Updated -27/06/2018

i02895753

Main Hydraulic Pump - Install

SMCS - 5070-012

Installation Procedure

Table 1

Required Tools			
Tool	Part Number	Part Description	Qty
A	138-7575	Link Bracket	2
B	4C-8359	Eyebolt	1

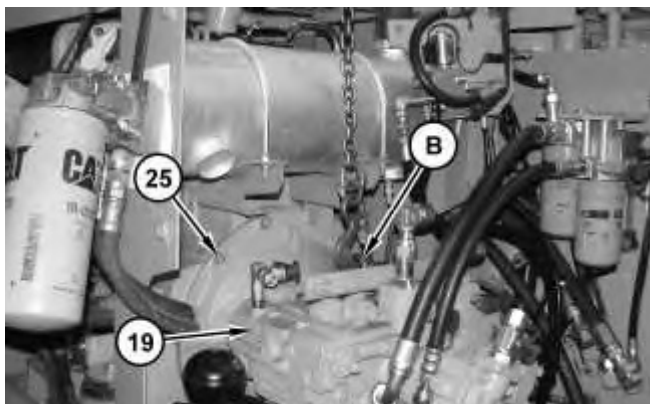


Illustration 1

g01441887

1. Attach Tooling (B) and a suitable lifting device to main hydraulic pump (19). The weight of main hydraulic pump (19) is approximately 147 kg (325 lb). Position main hydraulic pump (19) and install bolts (25).

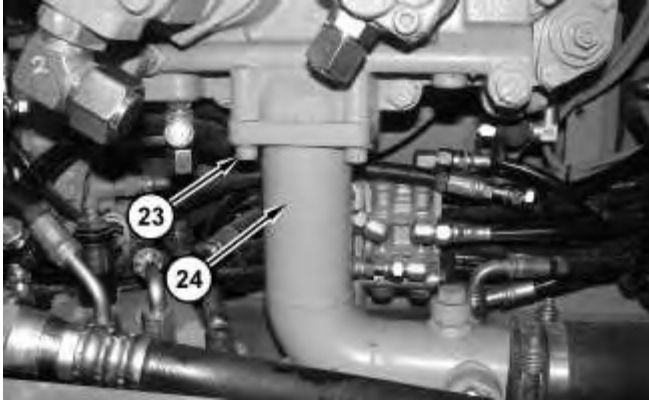


Illustration 2

g01441886

2. Position the O-ring seal. Connect tube assembly (24) and install bolts (23).

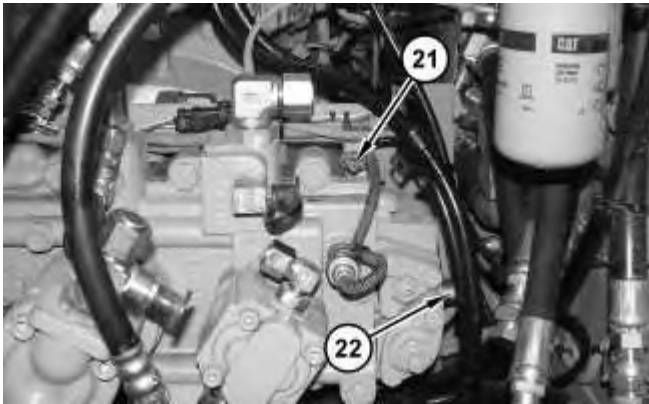


Illustration 3

g01441885

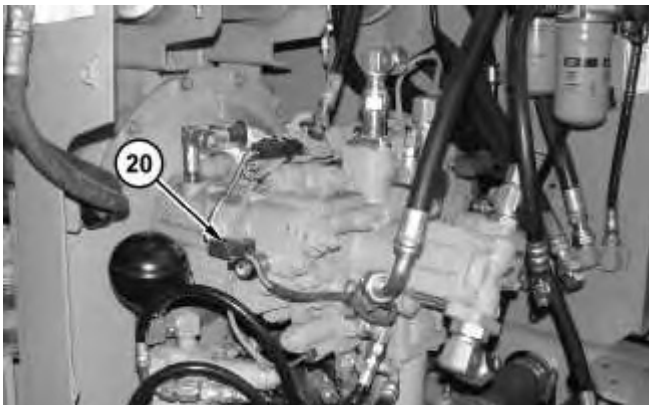


Illustration 4

g01441883

3. Position the harness assembly and install clip (22). Connect harness assemblies (21) and (20).

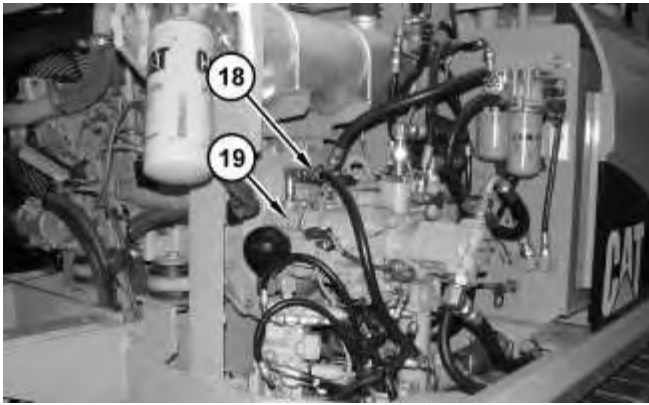


Illustration 5

g01441881

4. Connect all hose assemblies (18) to main hydraulic pump (19).

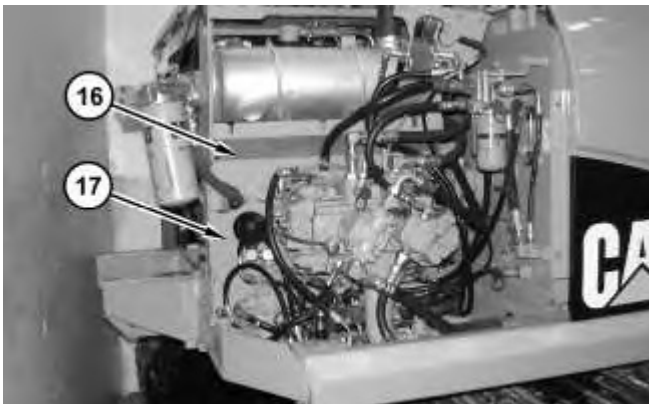


Illustration 6

g01441648

5. Position panel assemblies (16) and (17) and install the bolts.

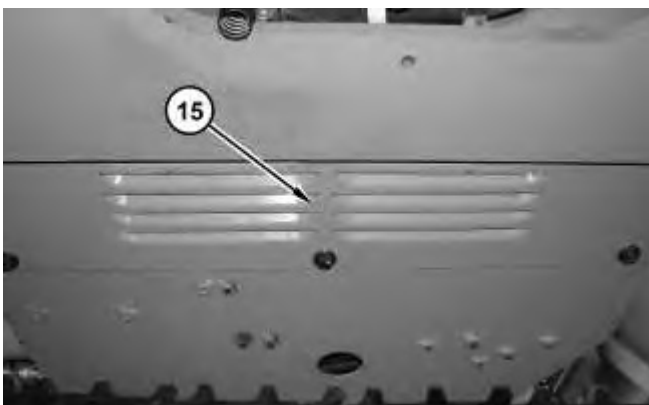


Illustration 7

g01441641

6. Install the bottom cover assembly (15).
-

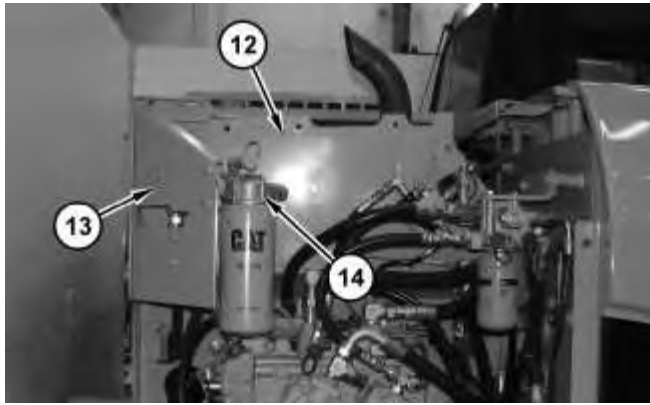


Illustration 8

g01441639

7. Position panel assemblies (12) and (13) and install the bolts.
8. Install filter assembly (14) onto panel assembly (13).

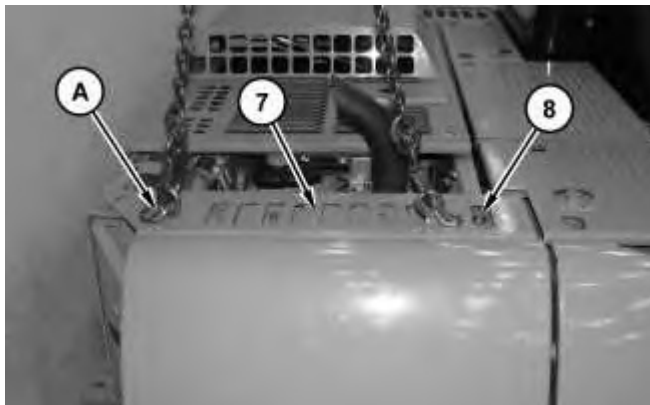


Illustration 9

g01441635

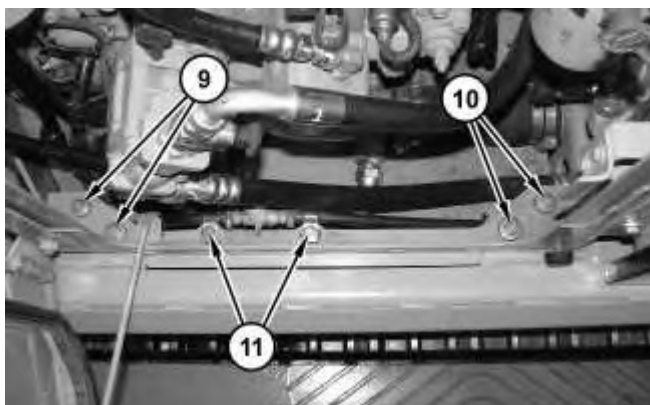


Illustration 10

g01441637

9. Attach Tooling (A) and a suitable lifting device to door assembly (7). Install bolts (8).
10. Install bolts (9) and (10). Position the hose assembly and install clips (11).

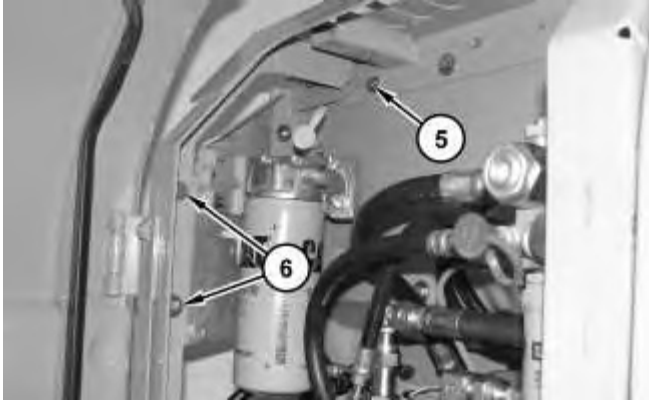


Illustration 11

g01441873

11. Install bolts (5) and (6).

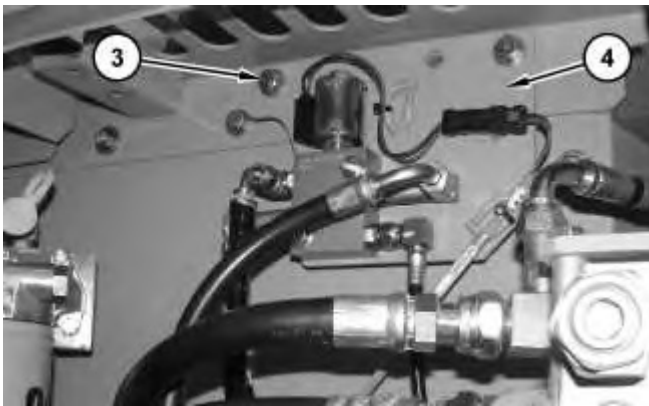


Illustration 12

g01441633

12. Position bracket (4) and install bolts (3).



Illustration 13

g01441632

13. Install bolts (2).



Illustration 14

g01441631

14. Install plate assembly (1).
15. Fill the hydraulic oil system. Refer to Operation and Maintenance Manual, "Hydraulic System Oil - Change".

End By:

- a. Install the counterweight. Refer to Disassembly and Assembly, "Counterweight - Remove and Install".

[Previous Screen](#)

Product: EXCAVATOR

Model: 313D2 LGP EXCAVATOR GAJ

Configuration: 313D2 LGP Excavator GAJ00001-UP (MACHINE) POWERED BY 3054C Engine

Disassembly and Assembly

313D2 Excavator Machine Systems

Media Number -UENR3323-06

Publication Date -01/06/2018

Date Updated -27/06/2018

i02649531

Pump Drive Coupling - Remove and Install

SMCS - 3253-010-PD; 5062-010

Removal Procedure

Start By:

- a. Remove the main hydraulic pump. Refer to Disassembly and Assembly, "Main Hydraulic Pump - Remove".

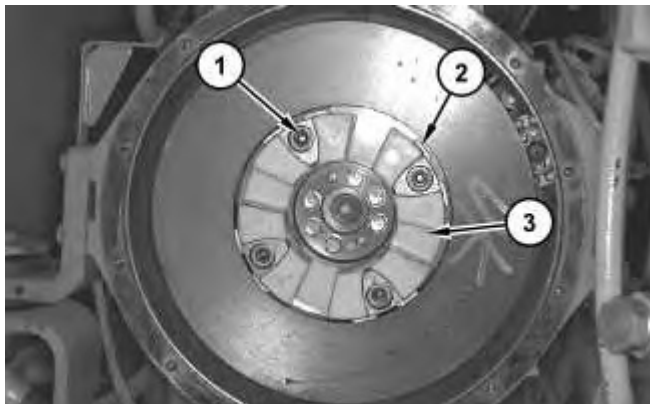


Illustration 1

g01330036

1. Remove bolts (1) and inserts (2). Remove element (3) from the engine flywheel.

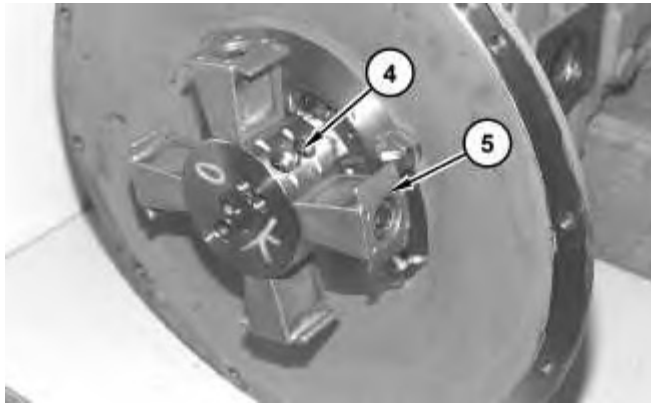


Illustration 2

g01330039

2. Loosen bolts (4) and remove coupling assembly (5).

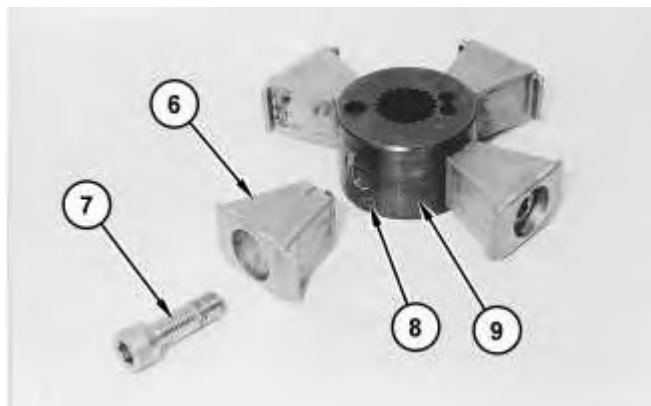


Illustration 3

g01330042

3. Remove bolts (7) and inserts (6). Remove pins (8) from hub (9).

Installation Procedure

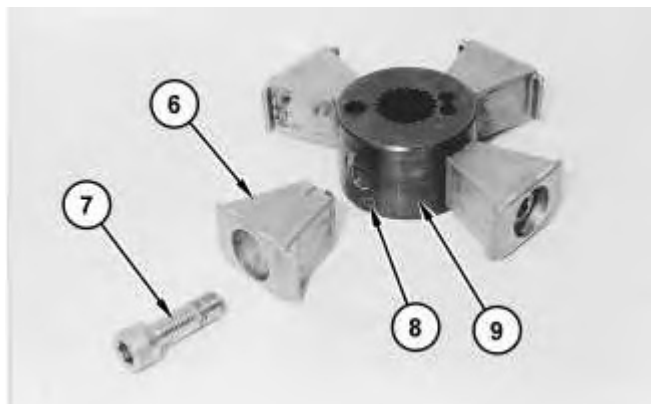


Illustration 4

g01330042

1. Install pins (8) into hub (9). Install inserts (6) and bolts (7). Tighten bolts (7) to a torque of $220 \pm 10 \text{ N}\cdot\text{m}$ ($162 \pm 7 \text{ lb ft}$).

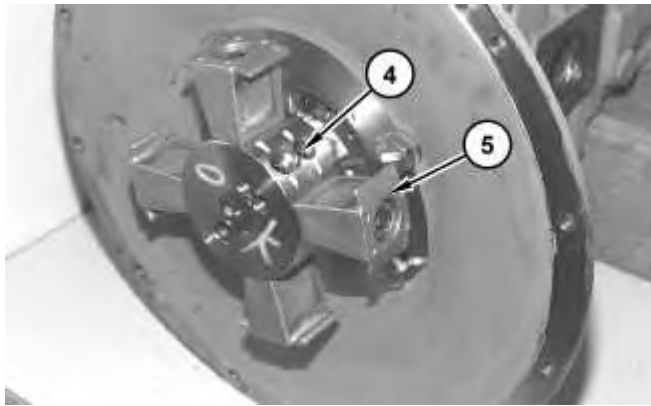


Illustration 5

g01330039

2. Install coupling assembly (5) and tighten bolts (4). Tighten bolts (4) to a torque of $110 \pm 10 \text{ N}\cdot\text{m}$ ($81 \pm 7 \text{ lb ft}$).

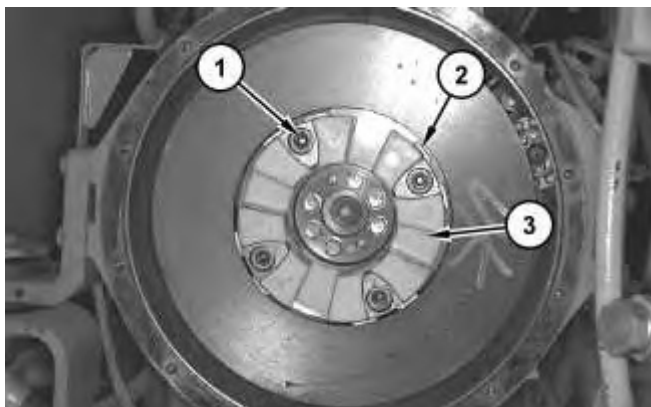


Illustration 6

g01330036

3. Install element (3) onto the engine flywheel. Install inserts (2) and bolts (1). Tighten bolts (1) to a torque of $220 \pm 10 \text{ N}\cdot\text{m}$ ($162 \pm 7 \text{ lb ft}$).

End By:

- a. Install the main hydraulic pump. Refer to Disassembly and Assembly, "Main Hydraulic Pump - Install".



Suggest:

If the above button click is invalid.

Please download this document

first, and then click the above link

to download the complete manual.

Thank you so much for reading

[Previous Screen](#)

Product: EXCAVATOR

Model: 313D2 LGP EXCAVATOR GAJ

Configuration: 313D2 LGP Excavator GAJ00001-UP (MACHINE) POWERED BY 3054C Engine

Disassembly and Assembly

313D2 Excavator Machine Systems

Media Number -UENR3323-06

Publication Date -01/06/2018

Date Updated -27/06/2018

i02616649

Pilot Valve (Joystick) - Remove

SMCS - 5059-011

Removal Procedure

Start By:

- a. Release the hydraulic system pressure. Refer to Disassembly and Assembly, "Hydraulic System Pressure - Release".

Note: The removal procedure is similar for both of the pilot valves. The procedure which follows is for the removal of the left hand pilot valve.

NOTICE

Care must be taken to ensure that fluids are contained during performance of inspection, maintenance, testing, adjusting, and repair of the product. Be prepared to collect the fluid with suitable containers before opening any compartment or disassembling any component containing fluids.

Refer to Special Publication, NENG2500, "Dealer Service Tool Catalog" for tools and supplies suitable to collect and contain fluids on Cat products.

Dispose of all fluids according to local regulations and mandates.

**WARNING**

<https://www.ebooklibonline.com>

Hello dear friend!

Thank you very much for reading.

Enter the link into your browser.

The full manual is available for immediate download.

<https://www.ebooklibonline.com>