



Service Repair Manual

Models

312E Excavator

[Previous Screen](#)

Product: EXCAVATOR

Model: 312E EXCAVATOR GAC

Configuration: 312E Excavator GAC00001-UP (MACHINE) POWERED BY C4.4 Engine

Disassembly and Assembly C4.4 Engines for Caterpillar Built Machines

Media Number -UENR0602-11

Publication Date -01/08/2013

Date Updated -25/10/2017

i04047880

Front Cover - Remove and Install

SMCS - 1166-010

Removal Procedure

Start By:

- a. Remove the crankshaft pulley. Refer to Disassembly and Assembly, "Crankshaft Pulley - Remove and Install" for the correct procedure.
 - b. If the engine has a fan, remove the fan. Refer to Disassembly and Assembly, "Fan - Remove and Install" for the correct procedure.
-

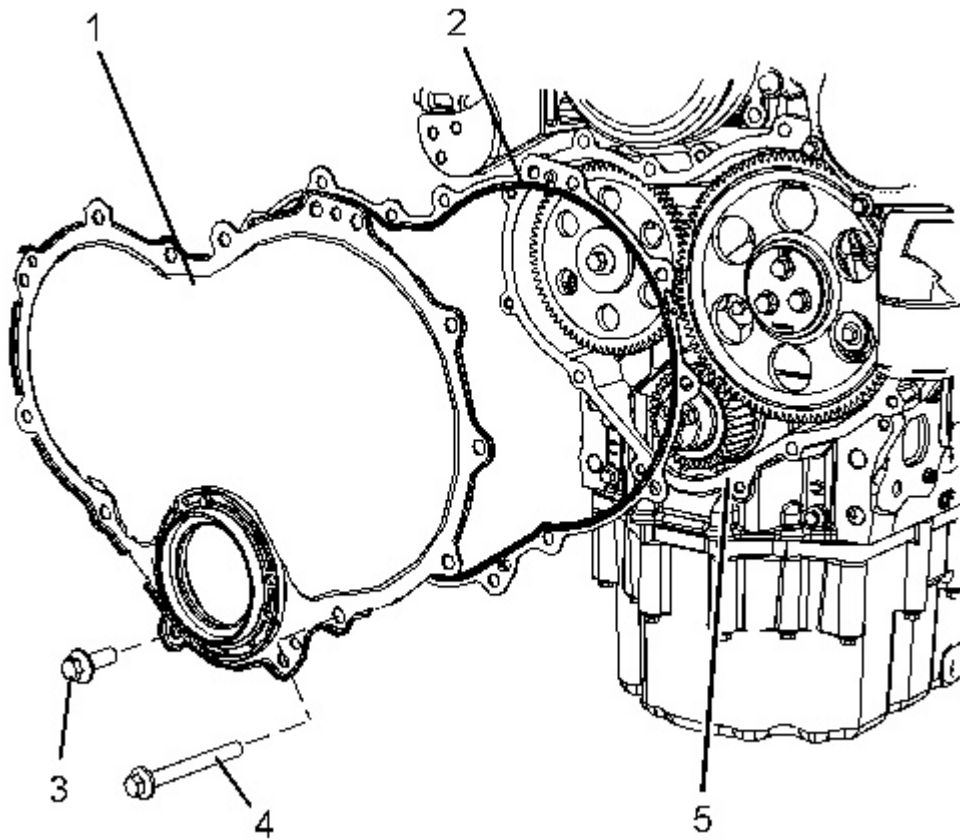

Illustration 1

g02481028

1. Remove the front seal from the front cover. Refer to Disassembly and Assembly, "Crankshaft Front Seal - Remove and Install" for the correct procedure.
2. Remove bolts (3) and bolts (4). Identify the positions of bolts of different length.
3. Remove front cover (1) from front housing (5).
4. Remove gasket (2).

Installation Procedure

Table 1

Required Tools			
Tool	Part Number	Part Description	Qty
A	-	Guide Stud M8 by 70 mm	2
B	342-9206	Front Cover Alignment Tool	1

<https://www.ebooklibonline.com>

Hello dear friend!

Thank you very much for reading.

Enter the link into your browser.

The full manual is available for immediate download.

<https://www.ebooklibonline.com>

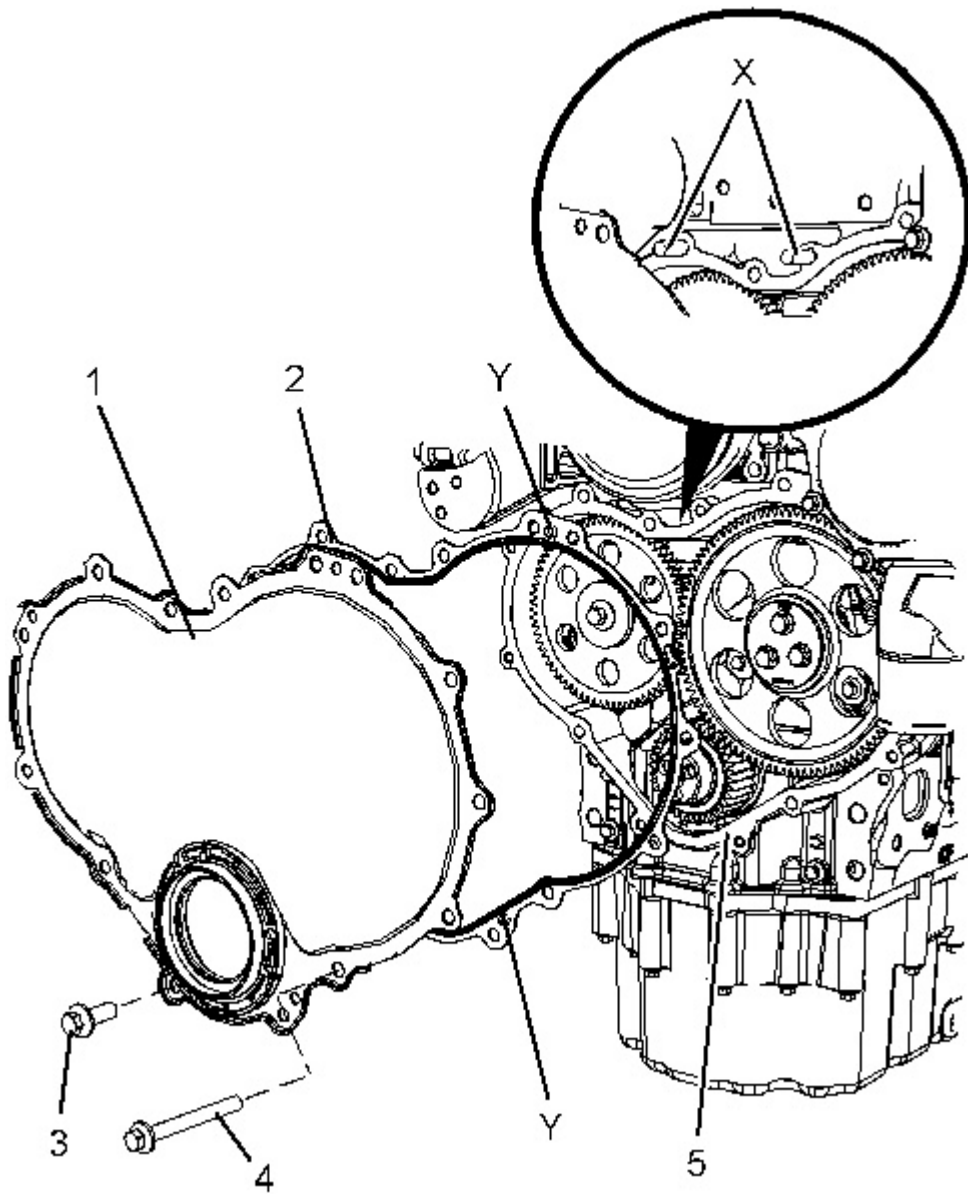

Illustration 2

g02481030

1. Thoroughly clean the gasket surface of the front housing.
2. If the original front cover is installed, follow Step 2.a through Step 2.b.
 - a. Thoroughly clean front cover (1).
 - b. Install a new gasket (2) to front cover (1). Engage Locators (Y) into the holes in the front cover.
3. Install Tooling (A) into Holes (X) in front housing (5).
4. Use Tooling (A) in order to position the front cover assembly onto the front housing.
5. Install bolts (3) and bolts (4) finger tight. Ensure that the bolts of different length are installed in the correct positions.

6. Install a new front seal to the front cover. Refer to Disassembly and Assembly, "Crankshaft Front Seal - Remove and Install" for the correct procedure.
7. Use Tooling (B) in order to align the front cover.
8. Remove Tooling (A) and install the remaining bolts.
9. Tighten bolts (3) and bolts (4) to a torque of 22 N·m (195 lb in).
10. Remove Tooling (B) from the front cover.

End By:

- a. Install the crankshaft pulley. Refer to Disassembly and Assembly, "Crankshaft Pulley - Remove and Install" for the correct procedure.
- b. If the engine has a fan, install the fan. Refer to Disassembly and Assembly, "Fan - Remove and Install" for the correct procedure.

[Previous Screen](#)

Product: EXCAVATOR

Model: 312E EXCAVATOR GAC

Configuration: 312E Excavator GAC00001-UP (MACHINE) POWERED BY C4.4 Engine

Disassembly and Assembly C4.4 Engines for Caterpillar Built Machines

Media Number -UENR0602-11

Publication Date -01/08/2013

Date Updated -25/10/2017

i04048571

Gear Group (Front) - Remove and Install - Heavy Duty Gear Group (Front)

SMCS - 1206-010

Removal Procedure

Table 1

Required Tools			
Tool	Part Number	Part Description	Qty
A	9U-7336	Housing	1
	5P-7305	Engine Turning Tool	1
B	230-6284	Timing Pin (Camshaft)	1
C	364-9107	Timing Pin (Fuel Injection Pump)	1
D	136-4632	Timing Pin (Crankshaft)	1
	268-1966	Adapter	1
E	298-5564	T40Torx Socket	1

Start By:

- a. Remove the front cover. Refer to Disassembly and Assembly, "Front Cover - Remove and Install" for the correct procedure.
- b. Remove the valve mechanism cover. Refer to Disassembly and Assembly, "Valve Mechanism Cover - Remove and Install" for the correct procedure.

NOTICE

Keep all parts clean from contaminants.

Contaminants may cause rapid wear and shortened component life.

NOTICE

Care must be taken to ensure that fluids are contained during performance of inspection, maintenance, testing, adjusting and repair of the product. Be prepared to collect the fluid with suitable containers before opening any compartment or disassembling any component containing fluids.

Dispose of all fluids according to local regulations and mandates.

Note: Care must be taken in order to ensure that the fuel injection pump timing is not lost during the removal of the front gear group. Carefully follow the procedure in order to remove the gear group.

1. If the air compressor is equipped with a hydraulic pump, remove the hydraulic pump. Refer to Original Equipment Manufactures (OEM) for the correct procedure.
2. If the engine is equipped with an air compressor, remove the air compressor. Refer to Disassembly and Assembly, "Air Compressor - Remove" for the correct procedure.
3. If the engine is equipped with only a hydraulic pump, remove the hydraulic pump. Refer to OEM for the correct procedure.
4. Use Tooling (A) in order to rotate the crankshaft so that number one piston is at top dead center on the compression stroke. Refer to System Operation, Testing and Adjusting, "Finding Top Center Position for No.1 Piston" for the correct procedure.

Note: Do not use excessive force to install Tooling (D). Do not use Tooling (D) to hold the crankshaft during repairs.

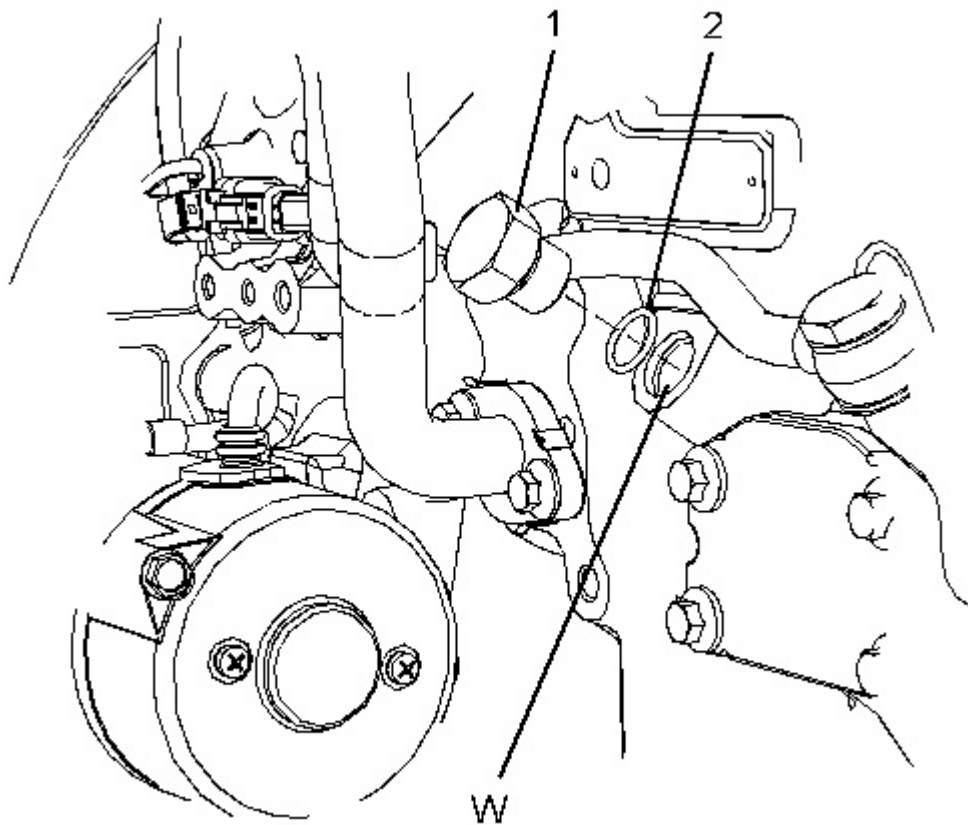

Illustration 1

g02486477

5. Remove plug (1) from the cylinder block. Remove O-ring seal (2) from the plug.
 6. Use Tooling (A) in order to rotate the crankshaft so that number one piston is at top dead center on the compression stroke. Refer to System Operation, Testing and Adjusting, "Finding Top Center Position for No.1 Piston" for the correct procedure. Install Tooling (D) through Hole (W) in order to lock the crankshaft so that number one piston is at top dead center on the compression stroke.
 7. Remove Tooling (D).
 8. Use Tooling (A) in order to rotate the crankshaft in a clockwise direction and position the crankshaft at the safe position. Refer to System Operation, Testing and Adjusting, "Position the Valve Mechanism Before Maintenance Procedures" for the correct procedure.
-

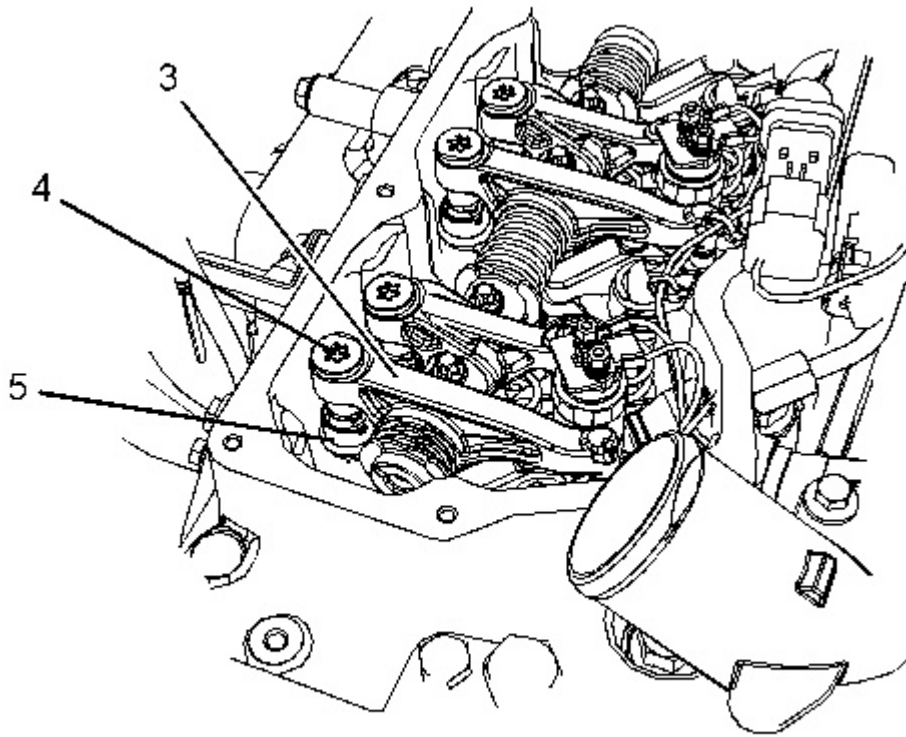

Illustration 2

g02048655

9. Use Tooling (E) in order to loosen threaded inserts (4) on all rocker arms (3). Unscrew threaded inserts (4) on all rocker arms (3) until all valves are fully closed. Ensure that the guides (5) for the pushrods are left in position on the threaded inserts (4).

Note: Ensure that ALL threaded inserts are fully unscrewed.

10. Use Tooling (A) in order to rotate the crankshaft so that number one piston is at top dead center on the compression stroke. Refer to System Operation, Testing and Adjusting, "Finding Top Center Position for No.1 Piston" for the correct procedure. Install Tooling (D) through Hole (W) in order to lock the crankshaft so that number one piston is at top dead center on the compression stroke. Refer to Illustration 1.
-

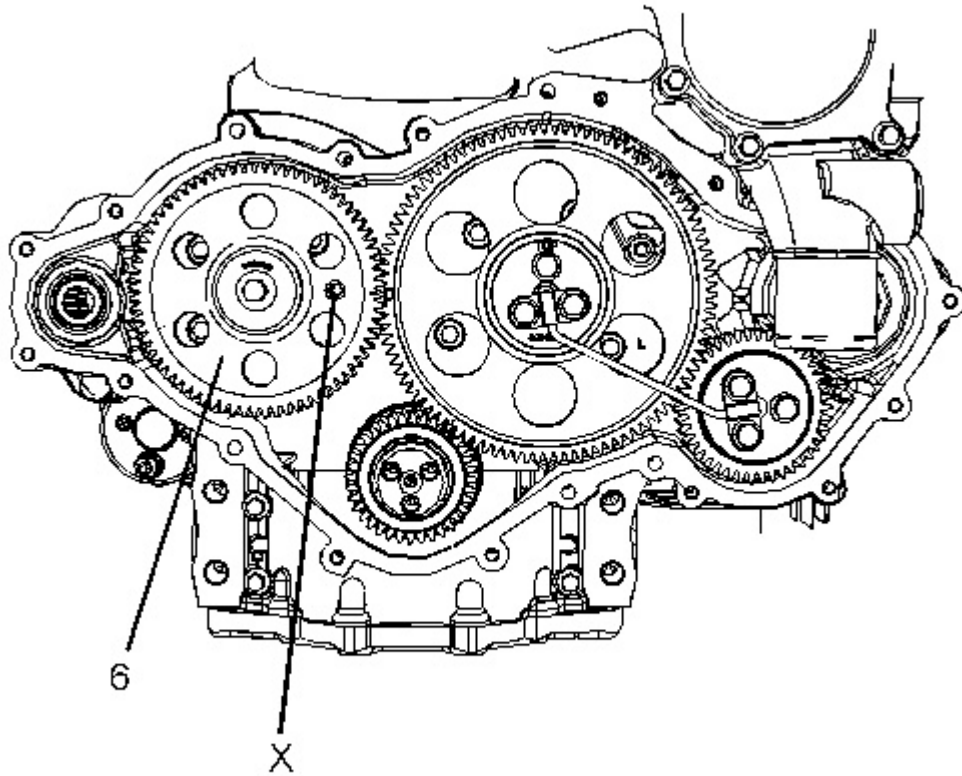

Illustration 3

g02488136

11. Install Tooling (B) through Hole (X) in camshaft gear (6) into the front housing. Use Tooling (B) in order to lock the camshaft in the correct position. Refer to System Operation, Testing and Adjusting, "Finding Top Center Position for No.1 Piston" for the correct procedure.
 12. Use Tooling (C) in order to lock the fuel injection pump gear in the correct position. Refer to Disassembly and Assembly, "Fuel Injection Pump - Remove" for the correct procedure.
-

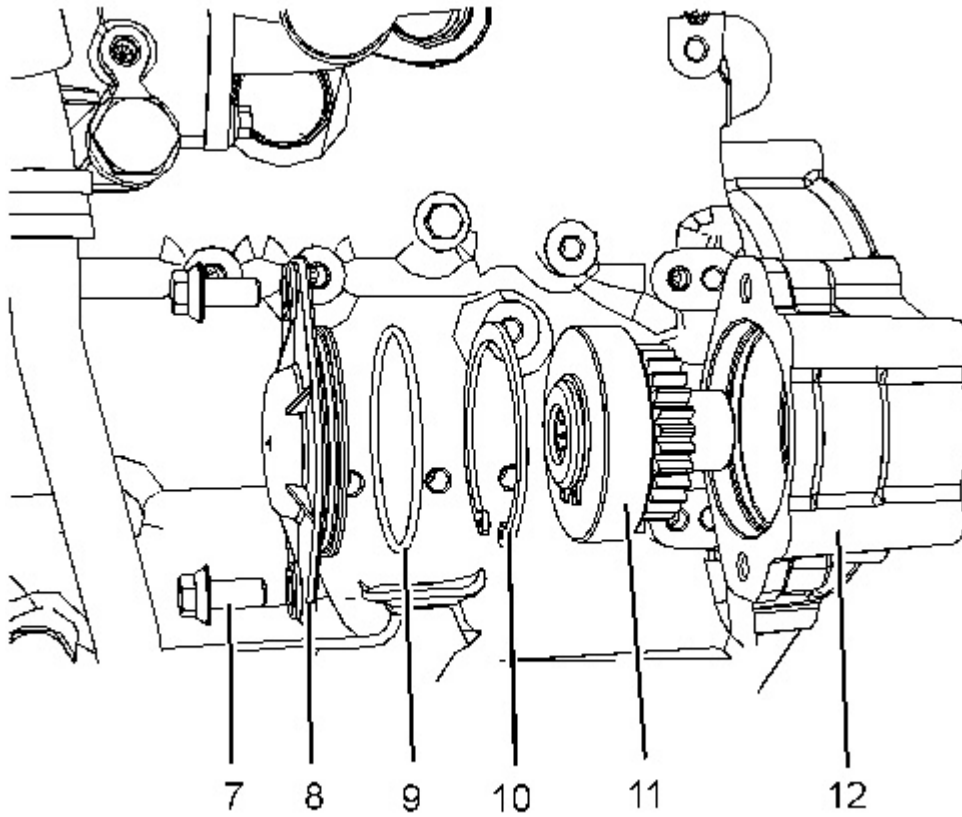

Illustration 4

g02052394

13. If the right-hand side of the engine is equipped with a hydraulic pump, remove the hydraulic pump. Refer to OEM for the correct procedure.
 14. If necessary, remove bolts (7) from plate (8). Remove plate (8) and remove O-ring seal (9).
 15. Remove circlip (10) and remove gear assembly (11) from front housing (12).
-

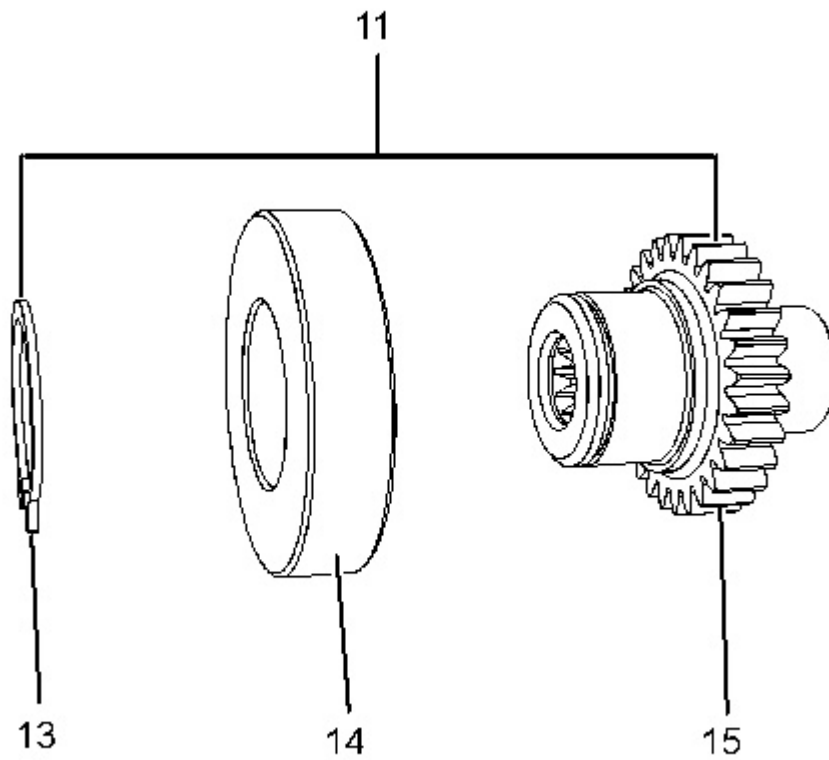

Illustration 5

g02053673

16. If necessary, follow Step 16.a through Step 16.b in order to disassemble gear assembly (11).
- Remove circlip (13) from gear assembly (11).
 - Place gear assembly (11) on a suitable support. Press bearing (14) from gear (15).
-

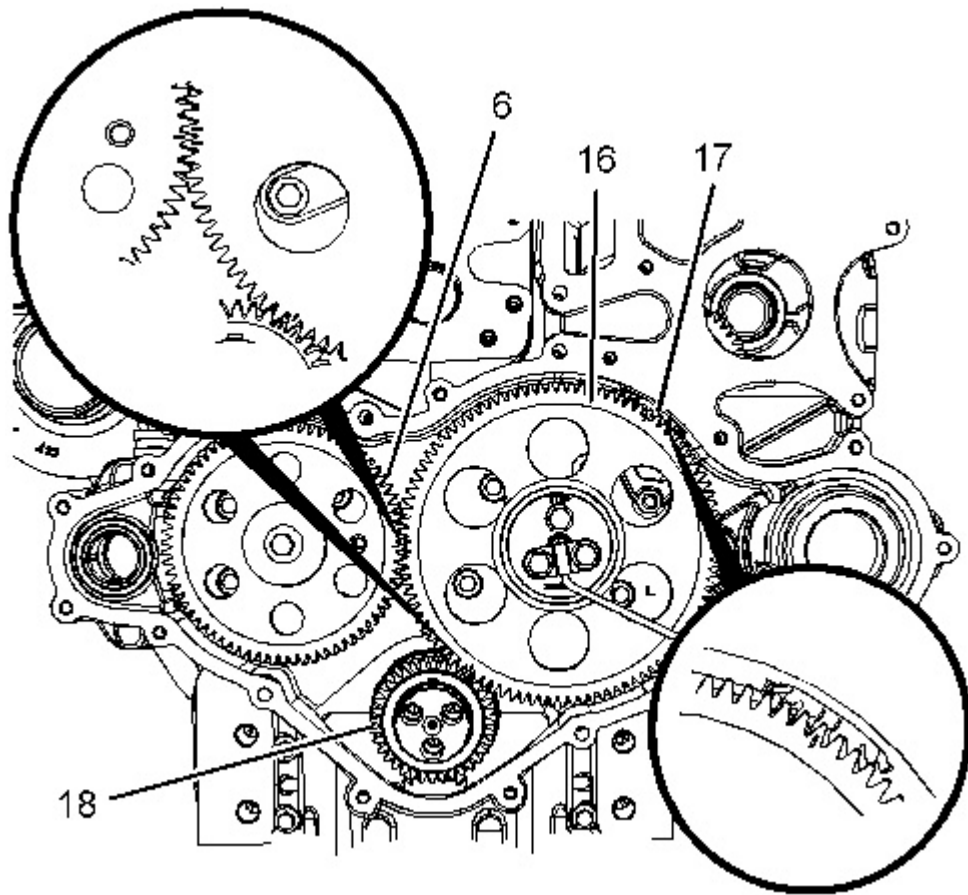

Illustration 6

g02048714

17. Mark gear (6), gear (16), gear (17) and gear (18) in order to show alignment. Refer to Illustration 6.

Note: Identification will ensure that the gears can be installed in the original alignment.

18. Remove camshaft gear (6). Refer to Disassembly and Assembly, "Camshaft Gear - Remove and Install" for the correct procedure.
-

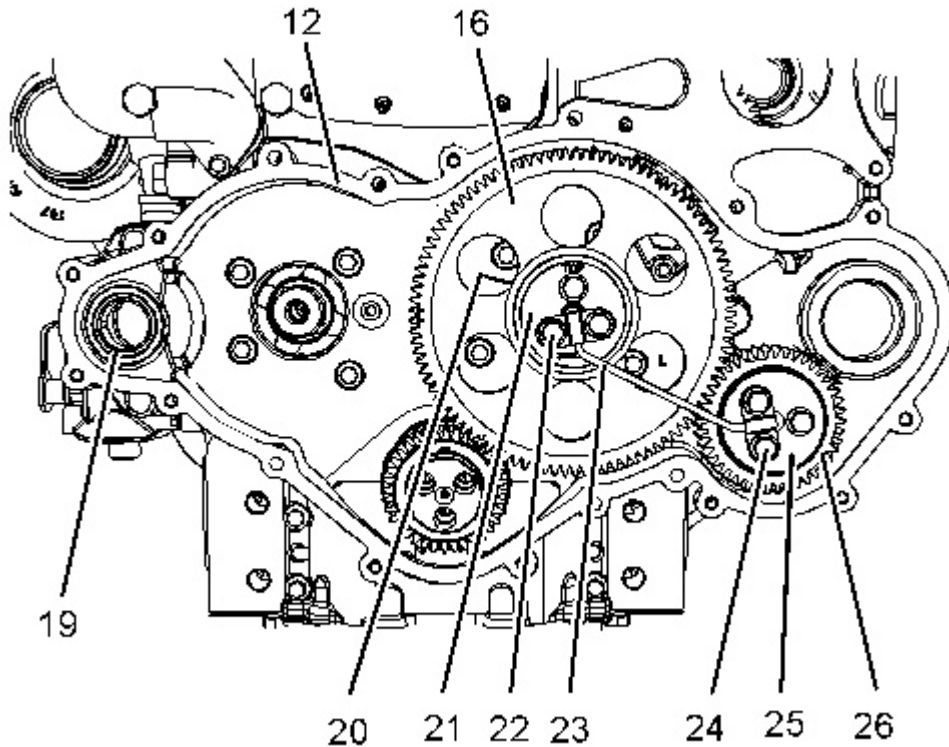

Illustration 7

g02053984

19. Remove bolts (22) and bolts (24).
20. Remove tube assembly (23) from idler gear (16) and idler gear (26).
21. Remove plate (21).
22. Remove idler gear (16) from hub (20) (not shown).
23. Remove idler gear (26) and idler gear hub (25) from front housing (12).
24. Remove hub (20) (not shown) from front housing (12).
25. If necessary, remove bearing (19) from front housing (12). Refer to Disassembly and Assembly, "Housing (Front) - Remove" for the correct procedure.

Installation Procedure

Table 2

Required Tools			
Tool	Part Number	Part Description	Qty
A	9U-7336	Housing	1
	5P-7305	Engine Turning Tool	1

B	230-6284	Timing Pin (Camshaft)	1
C	364-9107	Timing Pin(Fuel Injection Pump)	1
D	136-4632	Timing Pin (Crankshaft)	1
	268-1966	Adapter	1
E	298-5564	T40Torx Socket	1
F	207-1601	Rubber Lubricant	1
G	7M-7456	Bearing Mount Compound	1
H	9U-7324	Indicator Bracket	1
	7H-1942	Dial Indicator	1
	3S-3268	Indicator Contact Point	1
	7H-1940	Universal Attachment	1

NOTICE

Keep all parts clean from contaminants.

Contaminants may cause rapid wear and shortened component life.

Note: The fuel injection pump must remain locked until the procedure instructs you to unlock the fuel injection pump.

1. Ensure that number one piston is at top dead center on the compression stroke. Refer to System Operation, Testing and Adjusting, "Finding Top Center Position for No.1 Piston" for the correct procedure.
-

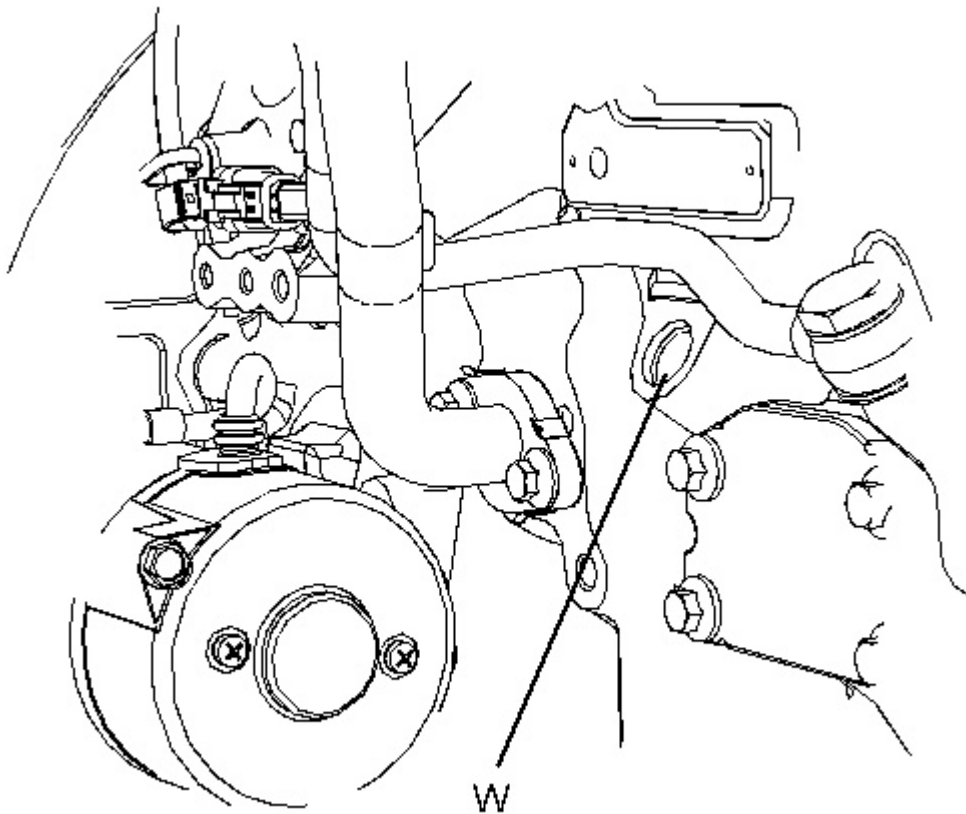

Illustration 8

g02488176

2. If necessary, install Tooling (D) into Hole (W) in the cylinder block. Use Tooling (D) in order to lock the crankshaft in the correct position. Refer to System Operation, Testing and Adjusting, "Finding Top Center Position for No.1 Piston" for the correct procedure.

Note: Do not use excessive force to install Tooling (D). Do not use Tooling (D) to hold the crankshaft during repairs.

3. Ensure that all of the components of the front gear group are clean and free from wear and damage. If necessary, replace any components that are worn or damaged.
-

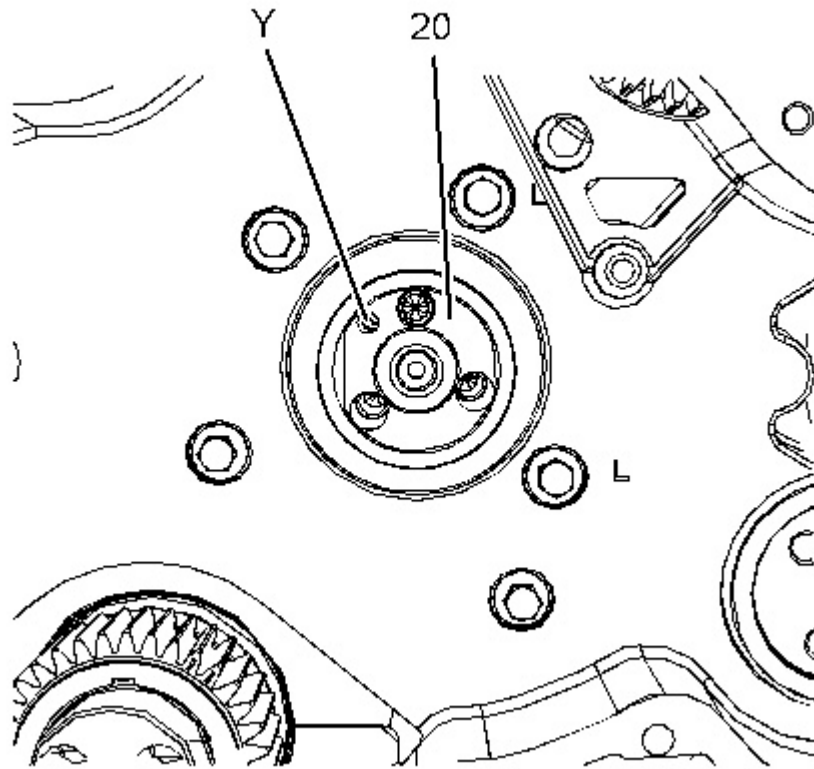

Illustration 9

g02048660

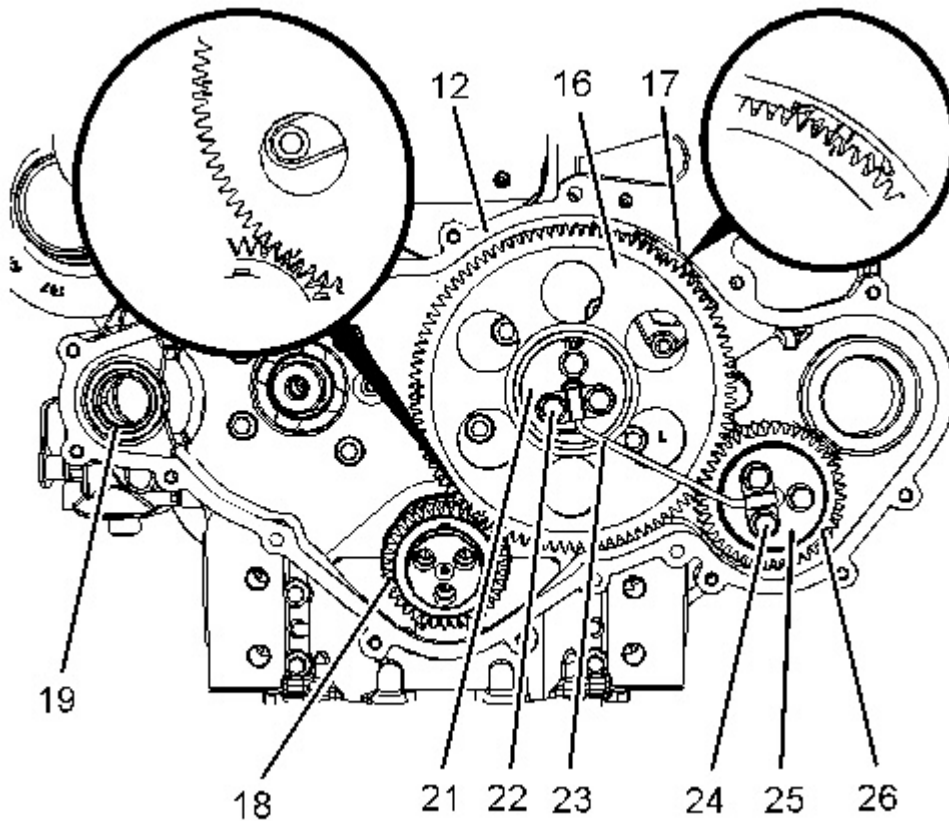

Illustration 10

g02053693

4. If necessary, Install bearing (19) to front housing (12). Refer to Disassembly and Assembly, "Housing (Front) - Install" for the correct procedure.
5. Install hub (20) to the recess of front housing (12). Ensure that the oil Hole (Y) is to the top of the hub.
6. Ensure that the fuel injection pump is locked in the correct position. Refer to Disassembly and Assembly, "Fuel Injection Pump - Install" for the correct procedure.
7. Lubricate idler hub (20) with clean engine lubricating oil. Install idler gear (16) to the idler hub. Ensure that the timing marks are toward the front of the idler gear. Align timing marks on idler gear (16) with gear (17) and gear (18).
8. Lubricate idler gear hub (25) with clean engine lubricating oil and install idler gear (26) to the idler gear hub. Install the assembly for idler gear (26) to front housing (12).

Note: Ensure that the idler gear hub and the idler gear are correctly aligned.

9. Position plate (21) onto idler gear (16).

Note: Ensure that the identification mark TOP is upward.

10. Position tube assembly (23) onto idler gear (16) and idler gear (26). Install bolts (22) and bolts (24).

Note: Ensure that the tube is correctly positioned on the hubs of the idler gears.

11. Tighten bolts (22) and bolts (24) to a torque of 44 N·m (32 lb ft).

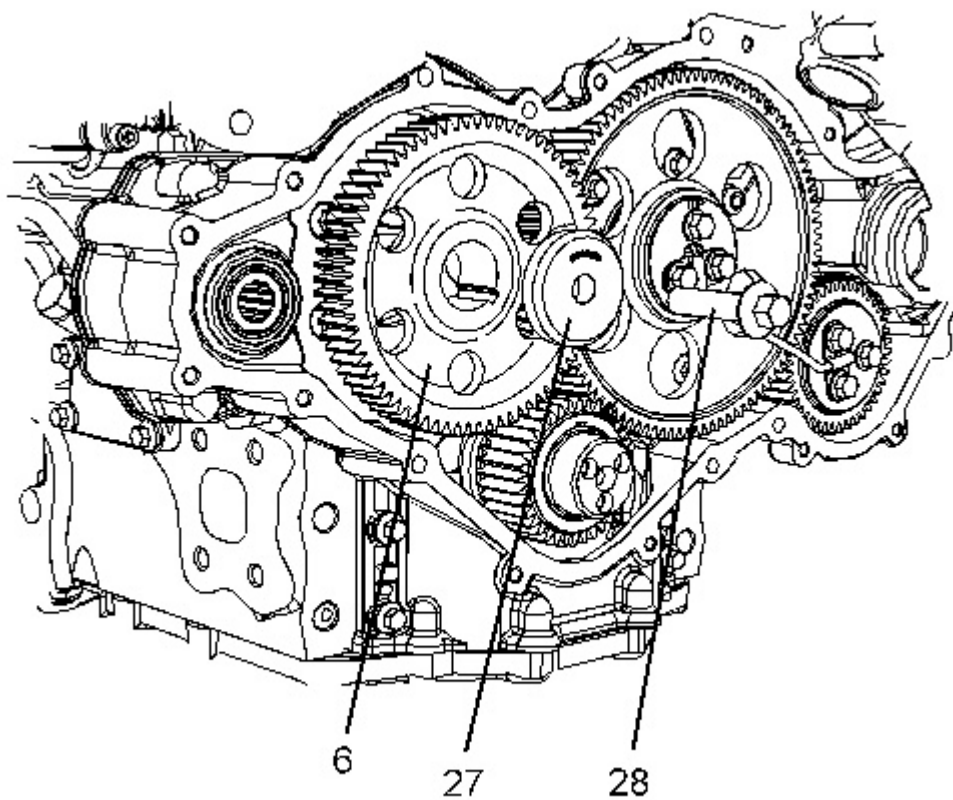

Illustration 11

g02488178

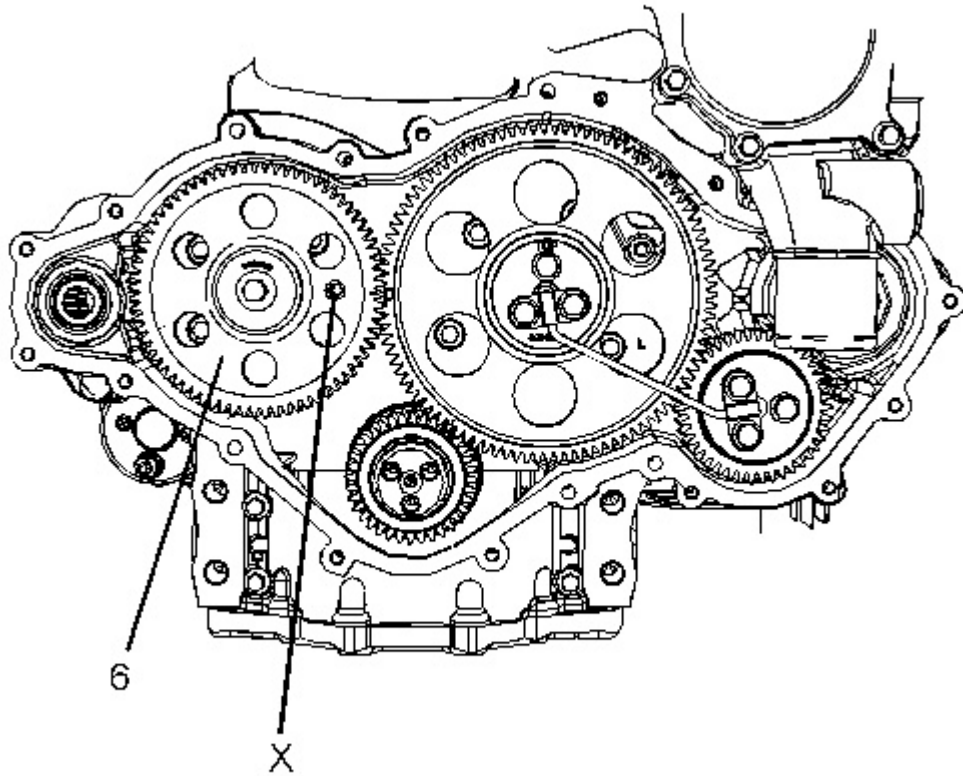

Illustration 12

g02488136

12. Install camshaft gear (6). Loosely install bolt (28) and washer (27) for the camshaft gear. Refer to Disassembly and Assembly, "Camshaft Gear - Remove and Install" for the correct procedure.
 13. Install Tooling (B) through Hole (X) in camshaft gear (6) into the front housing.
-

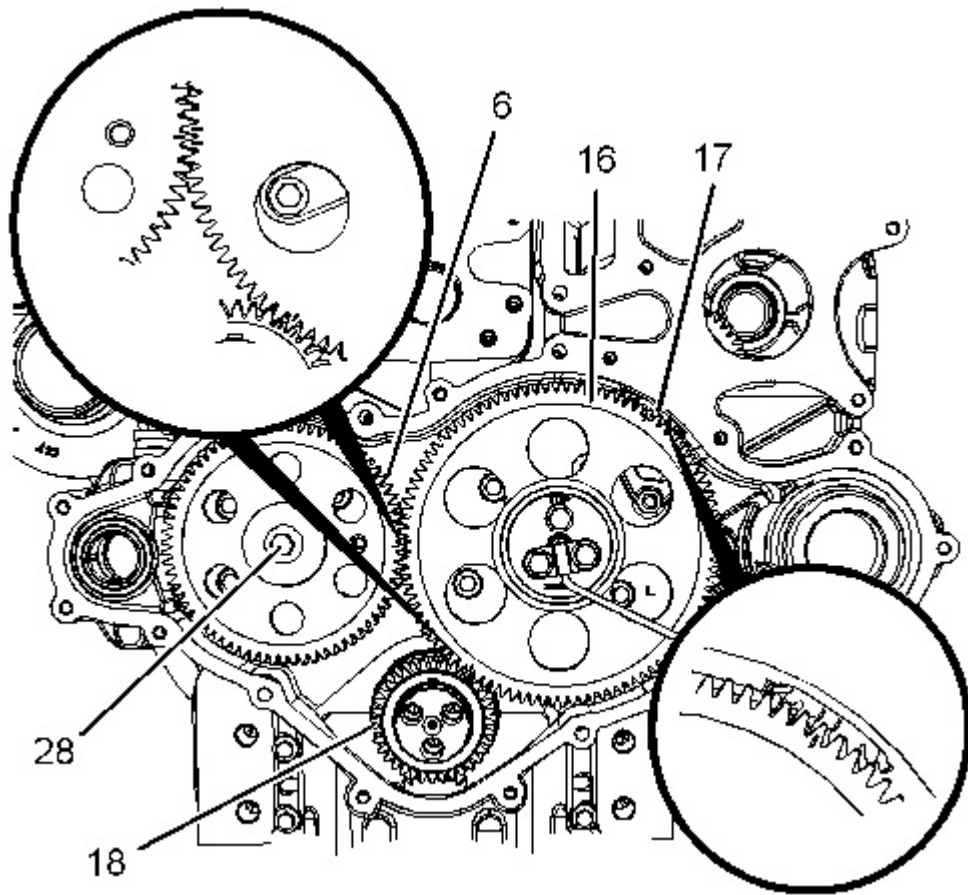

Illustration 13

g02488216

14. Ensure that the timing marks on gear (6), gear (16), gear (17) and gear (18) are in alignment and that the mesh of the gears is correct.
15. Remove Tooling (B), Tooling (C), and Tooling (D).
16. When bolt (28) is a 8.8 Grade. Tighten bolt (28) for camshaft gear (6) to a torque of 95 N·m (70 lb ft).
When bolt (28) is a 10.9 Grade. Tighten bolt (28) to a torque of 120 N·m (89 lb ft).
17. Use Tool (H) in order to check the end play of the camshaft gear. Refer to Specifications, "Camshaft" for more information.
18. Use Tool (H) in order to check the end play of the idler gears. Refer to Specifications, "Gear Group (Front)" and refer to Disassembly and Assembly, "Idler Gear - Remove and Install" for further information.
19. Use Tooling (H) in order to measure the backlash for gear (6), gear (16), gear (17) and gear (16). Refer to Specifications, "Gear Group (Front)" for further information.

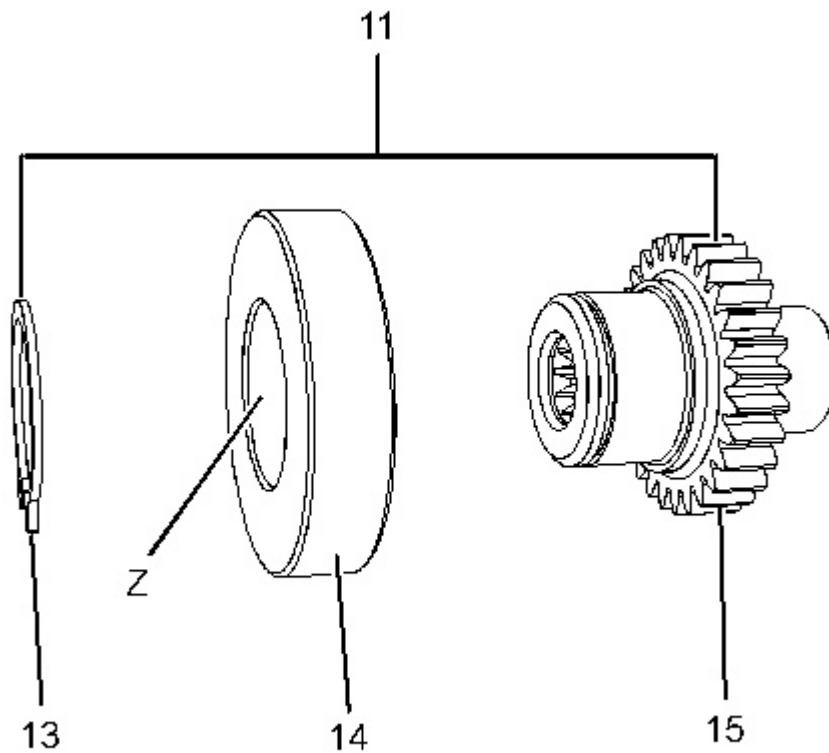

Illustration 14

g02058193

20. If necessary, follow Step 20.a through Step 20.c in order to assemble gear assembly (10).
- a. Apply a small continuous bead of Tooling (G) to inner Surface (Z) of bearing (14). Place the inner race of bearing (14) onto a suitable support. Press the shaft of gear (15) into bearing (14) until the shoulder of the gear is against the bearing. Remove any excess bearing mount compound.
 - b. Install circlip (13) to gear assembly (11).
 - c. Lightly lubricate bearing (14) and gear assembly (11) with clean lubricating oil.
-

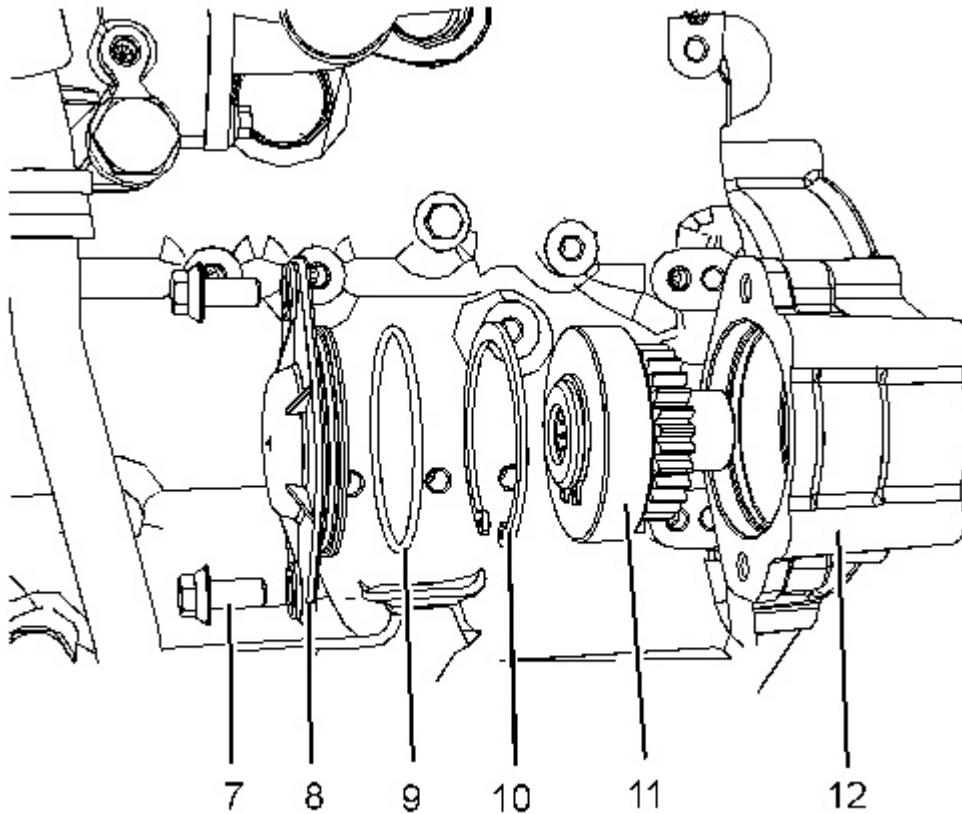

Illustration 15

g02052394

21. Install gear assembly (11) to front housing (12). Ensure that the shaft of gear assembly (11) is correctly aligned with the bearing in front housing (12).
22. Install circlip (10) to front housing (12).
Note: Ensure that the circlip is correctly located in the front housing.
23. Ensure that there is tactile backlash between the camshaft gear and the accessory drive gear.
24. If the right-hand side of the engine is equipped with a hydraulic pump, install the hydraulic pump. Refer to OEM for the correct procedure.
25. If necessary, lightly lubricate a new O-ring seal (9) with Tooling (F). Install new O-ring seal (9) to plate (8). Install plate (8) to front housing (12).
26. Install bolts (7) to plate (8). Tighten the bolts to a torque of 10 N·m (88 lb in).
27. Lubricate each gear with clean engine oil.

NOTICE

Failure to ensure that the crankshaft is positioned at the safe position will result in interference between the pistons and the valves.

Interference between the pistons and the valves will result in damage to the engine.

28. Use Tooling (A) in order to rotate the crankshaft in a clockwise direction and position the crankshaft at the safe position. Refer to System Operation, Testing and Adjusting, "Position the Valve Mechanism Before Maintenance Procedures" for the correct procedure.
-

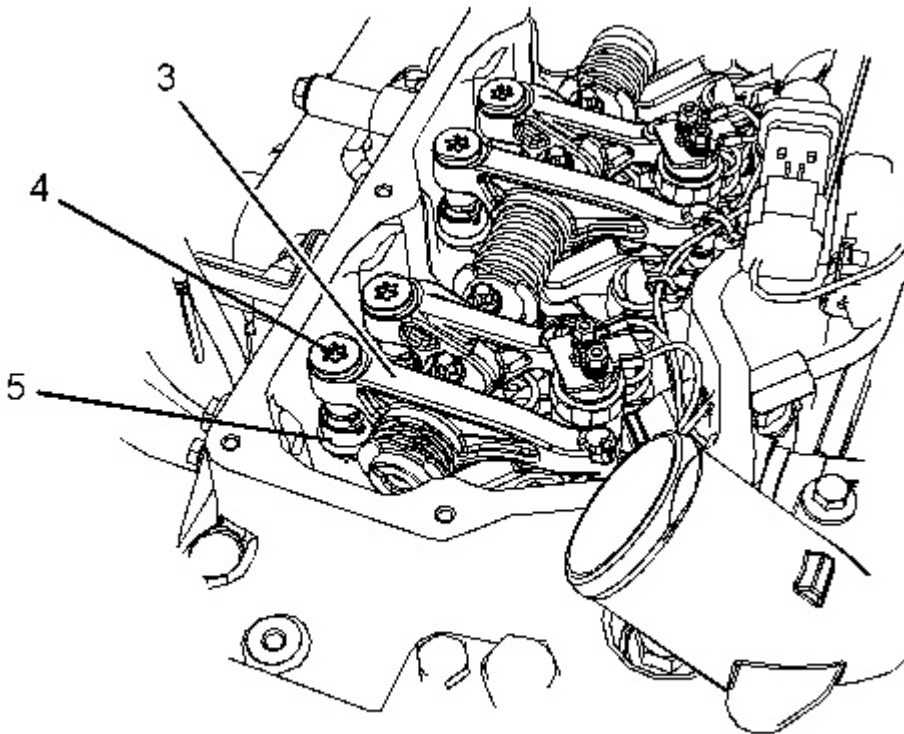

Illustration 16

g02048655

29. Ensure that the guides (5) for the pushrods are correctly positioned on the threaded inserts (4). Use Tooling (E) in order to tighten threaded inserts (4) on all rocker arms (3). Tighten the threaded inserts to a torque of 30 N·m (265 lb in).

Note: When the threaded insert is tightened, the threaded insert must be correctly seated into the cup for the pushrod.

30. If the engine is equipped with an air compressor, install the air compressor. Refer to Disassembly and Assembly, "Air Compressor - Install" for the correct procedure.
31. If the air compressor is equipped with a hydraulic pump, install the hydraulic pump. Refer to OEM for the correct procedure.
32. If the engine is equipped only with a hydraulic pump, install the hydraulic pump. Refer to OEM for the correct procedure.

33. The engine should not be operated for a period 30 minutes after the threaded inserts on all the rocker arms have been tightened. This period of time will allow the hydraulic lifters to purge off excessive engine oil from the hydraulic lifters.

End By:

- a. Install the front cover. Refer to Disassembly and Assembly, "Front Cover - Remove and Install" for the correct procedure.
- b. Install the valve mechanism cover. Refer to Disassembly and Assembly, "Valve Mechanism Cover - Remove and Install" for the correct procedure.

[Previous Screen](#)

Product: EXCAVATOR

Model: 312E EXCAVATOR GAC

Configuration: 312E Excavator GAC00001-UP (MACHINE) POWERED BY C4.4 Engine

Disassembly and Assembly C4.4 Engines for Caterpillar Built Machines

Media Number -UENR0602-11

Publication Date -01/08/2013

Date Updated -25/10/2017

i04048572

Gear Group (Front) - Remove and Install

SMCS - 1206-010

Removal Procedure

Table 1

Required Tools			
Tool	Part Number	Part Description	Qty
A	9U-7336	Housing	1
	5P-7305	Engine Turning Tool	1
B	230-6284	Timing Pin (Camshaft)	1
C	364-9107	Timing Pin (Fuel Injection Pump)	1
D	136-4632	Timing Pin (Crankshaft)	1
	268-1966	Adapter	1
E	298-5564	T40Torx Socket	1

Start By:

- a. Remove the front cover. Refer to Disassembly and Assembly, "Front Cover - Remove and Install" for the correct procedure.
- b. Remove the valve mechanism cover. Refer to Disassembly and Assembly, "Valve Mechanism Cover - Remove and Install" for the correct procedure.

NOTICE



Suggest:

If the above button click is invalid.

Please download this document

first, and then click the above link

to download the complete manual.

Thank you so much for reading

Keep all parts clean from contaminants.

Contaminants may cause rapid wear and shortened component life.

NOTICE

Care must be taken to ensure that fluids are contained during performance of inspection, maintenance, testing, adjusting and repair of the product. Be prepared to collect the fluid with suitable containers before opening any compartment or disassembling any component containing fluids.

Dispose of all fluids according to local regulations and mandates.

Note: Care must be taken in order to ensure that the fuel injection pump timing is not lost during the removal of the front gear group. Carefully follow the procedure in order to remove the gear group.

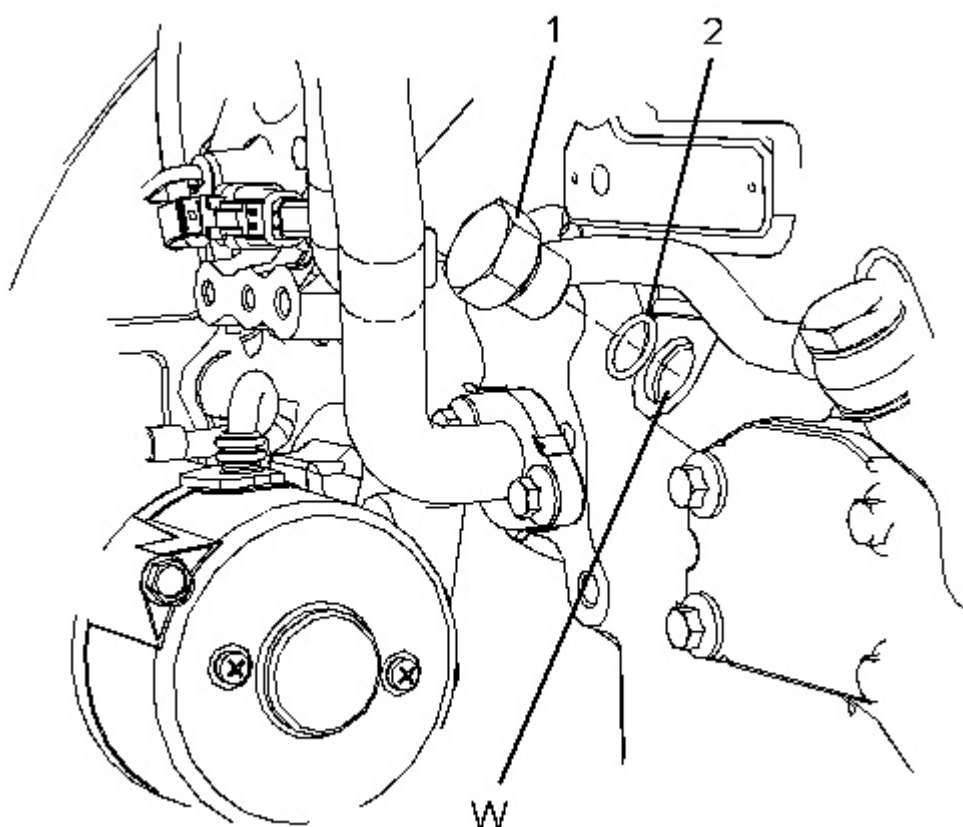

<https://www.ebooklibonline.com>

Hello dear friend!

Thank you very much for reading.

Enter the link into your browser.

The full manual is available for immediate download.

<https://www.ebooklibonline.com>