



Service Repair Manual

Models

120H ES Motor Grader

Previous Screen

Product: MOTOR GRADER

Model: 120H ES MOTOR GRADER 6NM

Configuration: 120H Motor Grader 6NM00001-UP (MACHINE) POWERED BY 3116 Engine

**Disassembly and Assembly
120H & 135H MOTOR GRADERS POWER TRAIN**

Media Number -SEN8543-02

Publication Date -01/09/2004

Date Updated -25/08/2009

SEN85430006

Parking Brake

SMCS - 4267-011; 4267-012

Remove Parking Brake

Tools Needed		A
1U-9752	Transmission Jack	1

⚠ WARNING

Be cautious of hot oil when draining the oil from the transmission and when disconnection and transmission oil lines Hot oil can cause burns. Stay clear of any oil that may spill during disconnected of transmission oil lines or draining of oil.

1. Drain the transmission oil in a suitable container for storage or disposal. The capacity of the power train system on the 120H and 135H Motor Graders is **47 Liters (50 qt)**.

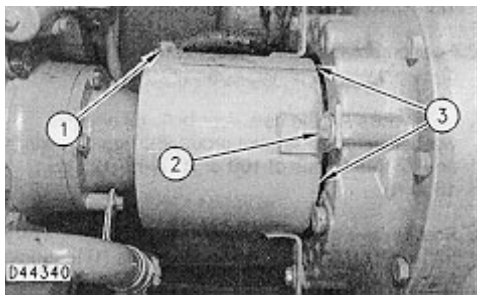

2. Remove bolts (1), the washers, bolts (2) and the washers from two guards (3). Remove two guard (3) from the front of the transmission.

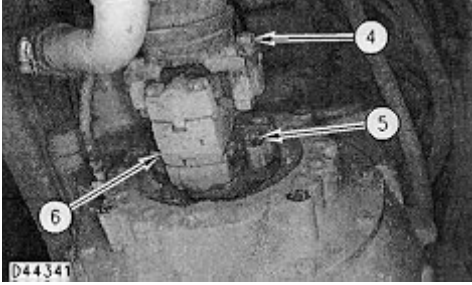

3. Remove four bolts (4), the nuts, four bolts (5) and the washers from universal joint group (6). Remove universal joint group (6) from the shaft.



Do not disconnect any air line from the machine until all the air pressure in the air tank is to zero. Release air pressure from the air tank by loosening the bleed valves. The bleed valves are underneath the rear bumper on the sides of the air tank.

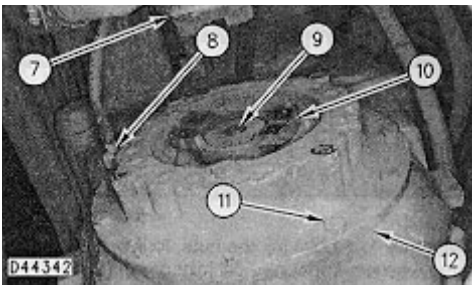

4. Release the air pressure from the air tank.

5. Disconnect air line (8) from the parking brake housing.

6. Remove bolt (9) and the washer that hold yoke (10) to the transmission shaft.

7. Remove yoke (10) and its O-ring seal from the transmission shaft.

8. Remove yoke (7) from the differential.

9. Remove all but two of bolts (11) from parking brake housing (12). Leave one bolt at the top and bolt at the bottom of parking brake housing (12).

<https://www.ebooklibonline.com>

Hello dear friend!

Thank you very much for reading.

Enter the link into your browser.

The full manual is available for immediate download.

<https://www.ebooklibonline.com>

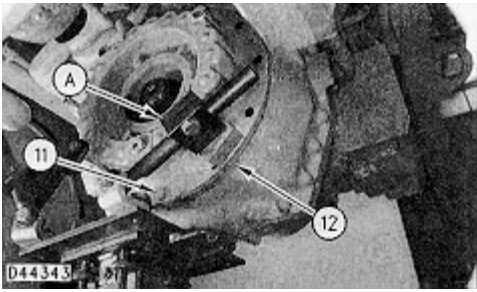

10. Attach Tooling (A) to parking brake housing (12).

11. Remove remaining bolts (11) from parking brake housing (12). Remove parking brake housing (12) from the transmission.

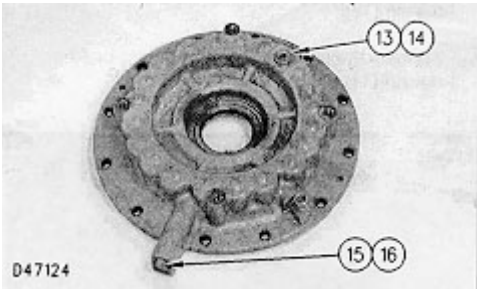

12. Remove plug (13) and O-ring seal (14) from parking brake housing (12).

13. Remove plug (15) and O-ring seal (16) from parking brake housing (12).

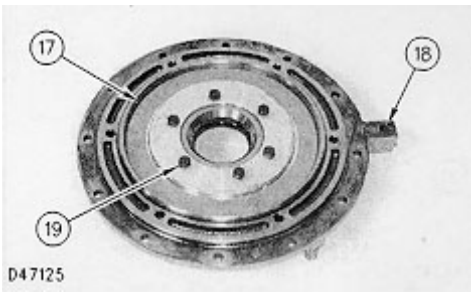

14. Remove six bolts (19) and the washers from piston (17). Remove piston (17) from parking brake housing (12).

15. Remove O-ring seal (18) from parking brake housing (12).

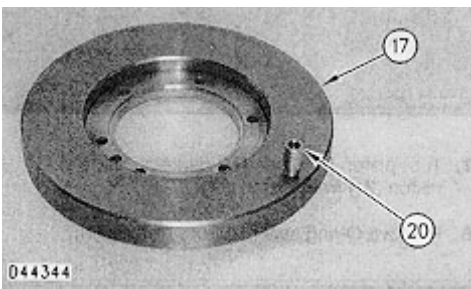

16. Remove plug (20) from piston (17).

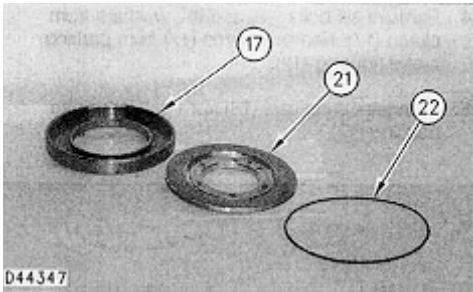
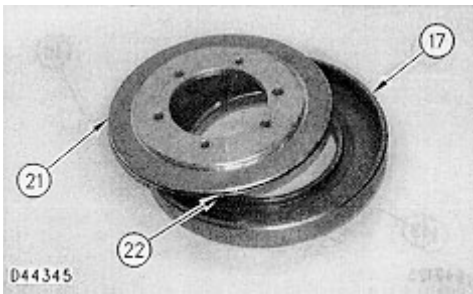

17. Turn piston (17) over 180 degrees. Separate piston (21) from piston (17).

18. Remove O-ring seal (22) from piston (21).

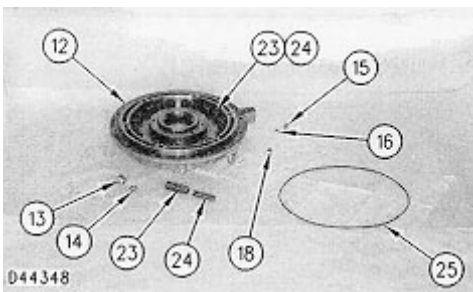

19. Remove twenty springs (23) and twenty springs (24) from parking brake housing (12).

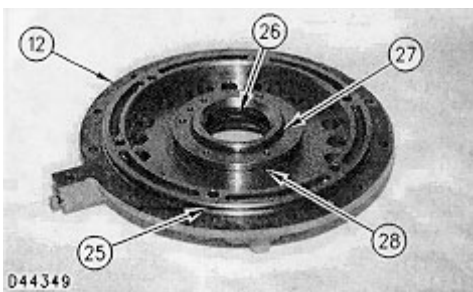

20. Remove O-ring seal (25) from parking brake housing (12).

21. Remove lip seal (26) from parking brake housing (12).

22. Remove O-ring seal (27) from parking brake housing (12).

23. Remove O-ring seal (28) from parking brake housing (12).

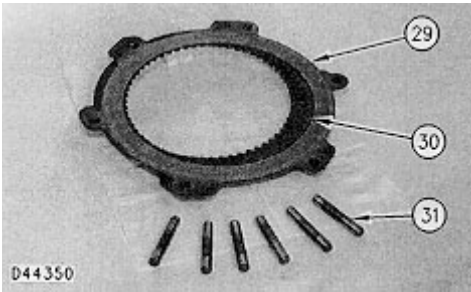
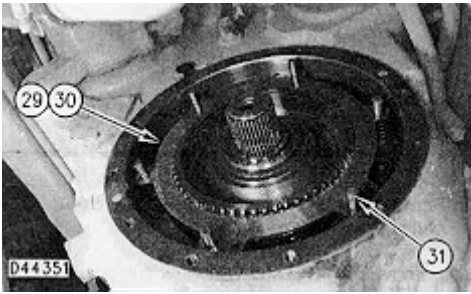

24. Remove six clutch plates (29) and five friction discs (30) from the transmission.

25. Remove six reaction dowels (31) from the transmission.

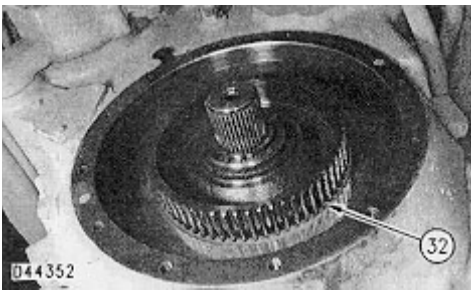

26. Remove clutch hub (32) from the transmission.

Install Parking Brake

Tools Needed		A
1U-9752	Transmission Jack	1

NOTE: During the installation of the parking brake, check the condition of all of the O-ring seals used in the assembly. If any of these seals are damaged, use new parts for replacement.

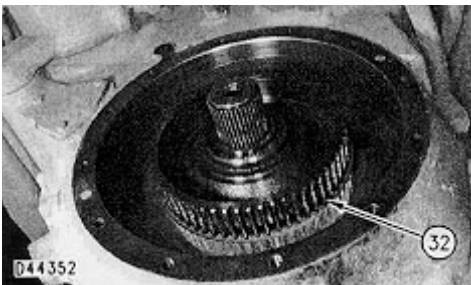

1. Install clutch hub (32) to the transmission.

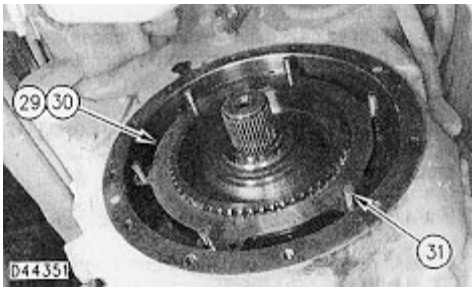
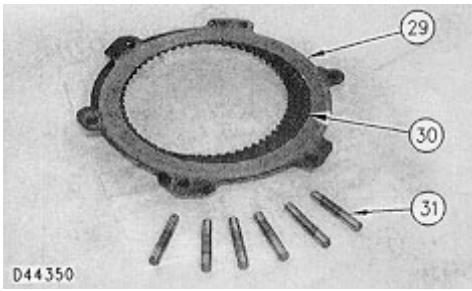

2. Install six reaction dowels (31) in the transmission.

3. Starting with a clutch plate, install six clutch plates (29) and five friction disc (30) in the transmission.

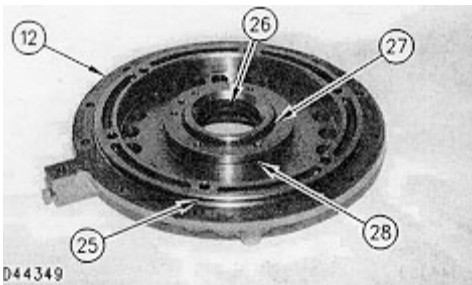

4. Install lip seal (26) to the parking brake housing (12). The sealing lip must face toward the transmission side of the parking brake housing. Lubricate the lip of the lip seal with clean transmission oil.

5. Install O-ring seal (27) in parking brake housing (12). Lightly lubricate O-ring seal (27) with clean transmission oil.

6. Install O-ring seal (28) in parking brake housing (12).

7. Install O-ring seal (25) to parking brake housing (12). Lightly lubricate O-ring seal (25) with clean transmission oil.

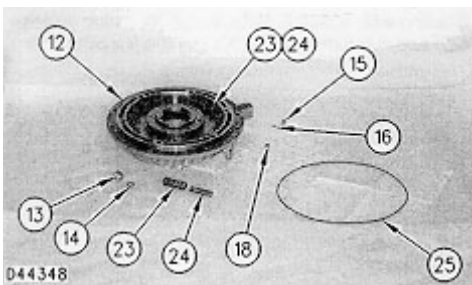

8. Install twenty springs (23) and twenty springs (24) in parking brake housing (12).

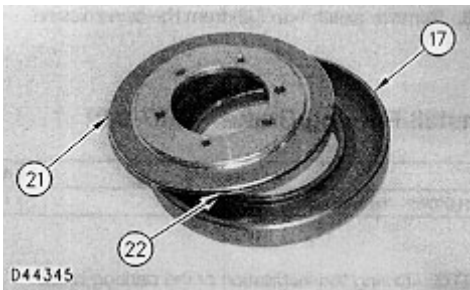
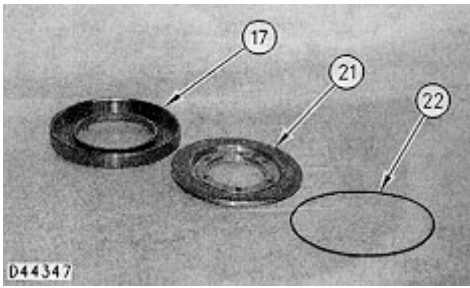

9. Install O-ring seal (22) to piston (21). Lightly lubricate O-ring seal (22) with clean transmission oil.

10. Install piston (21) in piston (17).

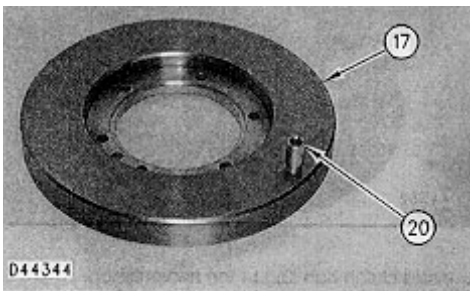

11. Install plug (20) in piston (17).

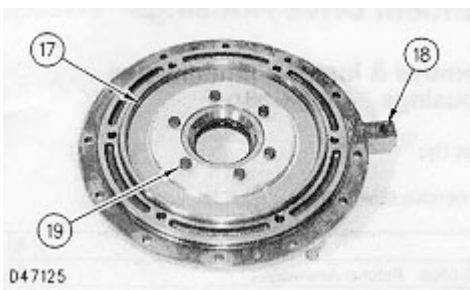

12. Install piston (17) in parking brake housing (12). Install six bolts (19) and the washers that hold piston (17) to parking brake housing (12).

13. Install O-ring seal (18) in parking brake housing (12).

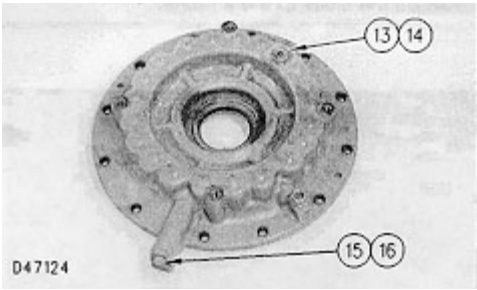

14. Install O-ring seal (16) on plug (15). Install plug (15) in parking brake housing (12).

15. Install O-ring seal (14) on plug (13). Install plug (13) in parking brake housing (12).

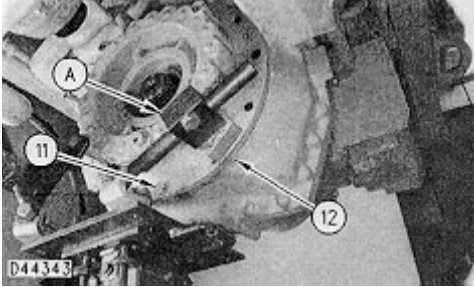

16. Install Tooling (A) to parking brake housing (12).

17. Position parking brake housing (12) to the transmission.

18. Install bolts (11) that hold parking brake housing (12) to the transmission.

19. Remove Tooling (A) from parking brake housing (12).

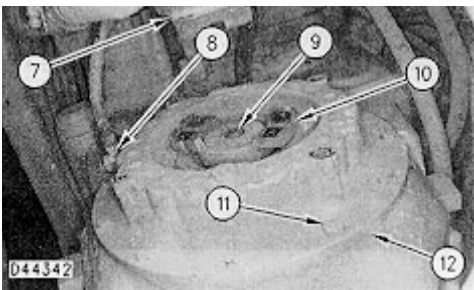

20. Install yoke (10) with its O-ring seal to the transmission shaft.

21. Install bolt (9) and the washer that hold yoke (10) to the transmission shaft. Tighten bolt (9) to a torque of $120 \pm 20 \text{ N}\cdot\text{m}$ ($90 \pm 15 \text{ lb ft}$).

22. Install yoke (7) to the differential.

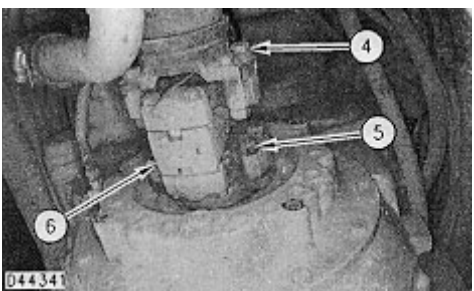

23. Position universal joint group (6) to the drive shaft. Install bolts (4), the nuts, bolts (5) and the washers that hold universal joint group (6) the drive shaft. Tighten bolts (4) and (5) to a torque of **160 ± 25 N·m (120 ± 18 lb ft)**.

24. Connect air line (8) to its fitting on parking brake housing (12).

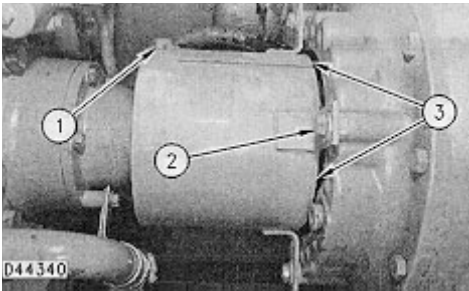

25. Position two guards (3) to the front of parking brake housing (12). Install bolts and washer (1) that hold two guards (3) together. Install bolts and washers (2) that hold the guards to the front of parking brake housing (12).

26. Fill the transmission with oil to the proper level. Refer to the "Operations and Maintenance Manual" for the proper procedure of filling the transmission.

Previous Screen

Product: MOTOR GRADER

Model: 120H ES MOTOR GRADER 6NM

Configuration: 120H Motor Grader 6NM00001-UP (MACHINE) POWERED BY 3116 Engine

Disassembly and Assembly
120H & 135H MOTOR GRADERS POWER TRAIN

Media Number -SEN8543-02

Publication Date -01/09/2004

Date Updated -25/08/2009

SEN85430007

Tandem Drive Housings

SMCS - 4064-010

Remove & Install Tandem Drive Housings

Start By:

- a. remove drive chains

Tools Needed		A
8S-9906	Ratchet Assembly	2



Do not disconnect any air line from the machine until all the air pressure in the air tank is to zero. Release air pressure from the air tank by loosening the bleed valves. The bleed valves are underneath the rear bumper on the sides of the air tank.

1. Disconnect air line (1) from the junction block.

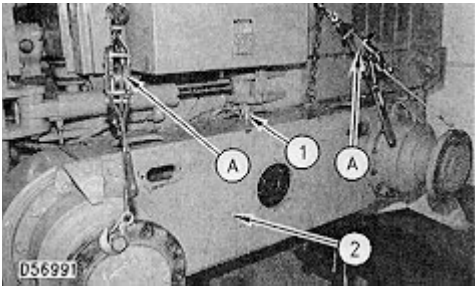

2. Attach chains and a hoist to tandem drive housing (2). Install Tooling (A) on the brake and wheel spindle housing and to the hoist.

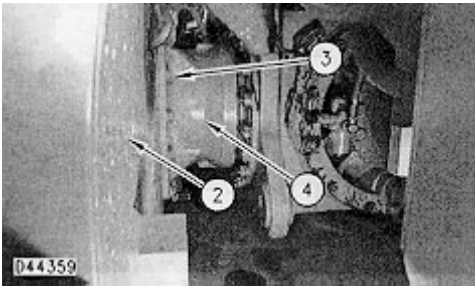

Back Side Of Tandem Drive Housing

3. Remove bolts and washers (3) that hold tandem drive housing (2) to final drive (4).
4. Remove tandem drive housing (2). The weight of tandem drive housing (2) is **594 kg (1310 lb)**.

NOTE: The following steps are for the installation of the tandem drive housings.

5. Attach chains and a hoist to tandem drive housing (2). Install Tooling (A) on the brake and wheel spindle housing and to the hoist. Position the tandem drive housing to the final drive.

6. Apply 9S-3263 Thread Lock Compound on bolts (3). Install bolts and washers (3) to final drive (4) and tandem drive housing (2). Do not use the four corner bolts to pull the final drive housing and tandem into initial contact. Then tighten the inner bolts first. Tighten the bolts to a torque of $120 \pm 20 \text{ N}\cdot\text{m}$ ($90 \pm 15 \text{ lb ft}$) on 120H Motor Graders and $240 \pm 40 \text{ N}\cdot\text{m}$ ($175 \pm 30 \text{ lb ft}$) on 135H Motor Graders.

7. Connect air line (1) to the block on tandem drive housing (2).

End By:

a. install drive chains

[Previous Screen](#)

Product: MOTOR GRADER

Model: 120H ES MOTOR GRADER 6NM

Configuration: 120H Motor Grader 6NM00001-UP (MACHINE) POWERED BY 3116 Engine

Disassembly and Assembly 120H & 135H MOTOR GRADERS POWER TRAIN

Media Number -SEN8543-02

Publication Date -01/09/2004

Date Updated -25/08/2009

SENR85430008

Drive Sprockets

SMCS - 4072-011; 4072-012

Remove Drive Sprockets

Tools Needed		A
5P-6153	Spanner Socket	1

Start By:

a. remove tandem housings

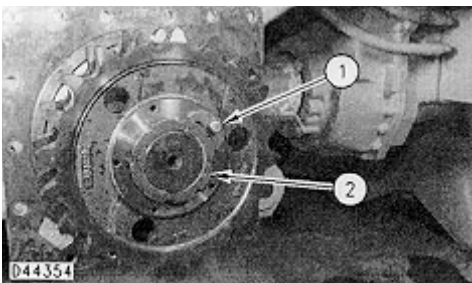

1. Remove bolt (1) and the clamp from spanner nut (2).

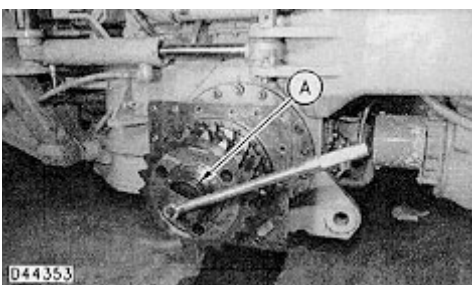

2. Use Tool (A) in order to remove spanner nut (2) from the drive sprocket shaft.

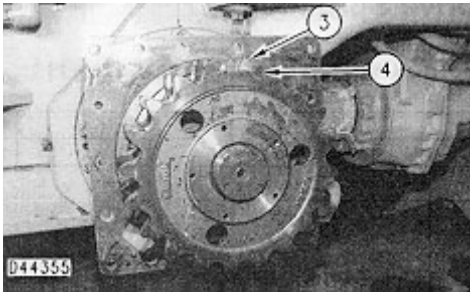

3. Remove sprockets (3) and (4) from the drive sprocket shaft. The weight of each sprocket is **15 kg (33 lb)**.

Install Drive Sprockets

Tools Needed		A
5P-6153	Spanner Socket	1

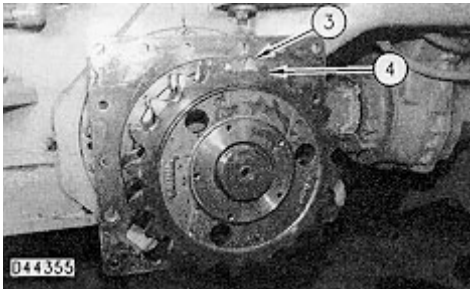

1. Position sprocket (3) on the drive sprocket shaft with the hub of the sprocket facing away from the final drives.

2. Position sprocket (4) on the drive sprocket shaft with the hub of the sprocket facing toward the hub of sprocket (3).

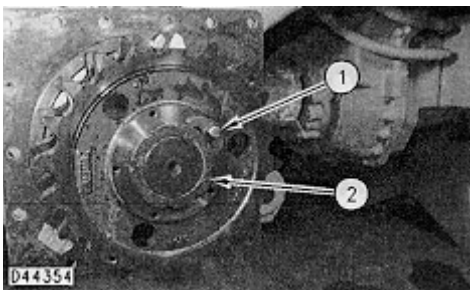

3. Install spanner nut (2) that holds sprockets (4) and (3) on the drive sprocket shaft.

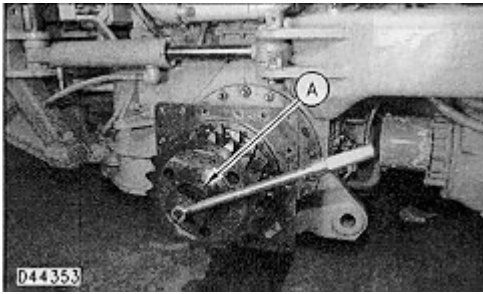

4. Use Tool (A) in order to tighten spanner nut (2) to the proper torque. The procedure is as follows:

a. Rotate the shaft and rap the sprockets while tightening nut (2) in order to preload the bearings. Tighten nut (2) to a torque of **$12 \pm 1 \text{ N}\cdot\text{m}$ ($100 \pm 10 \text{ lb in}$)**.

b. Back the nut off one locking position and rap sprockets. This is done to assure that the bearings are fully seated.

c. Tighten nut (2) to a final rolling torque of **$4 \pm 1 \text{ N}\cdot\text{m}$ ($35 \pm 10 \text{ lb in}$) above seal drag.**

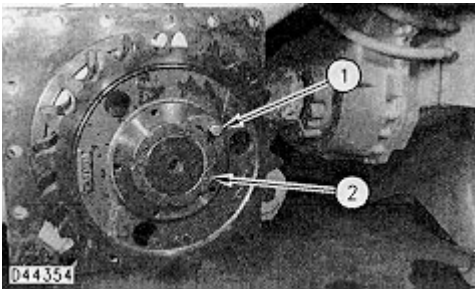

5. Install bolt (1) and the clamp on spanner nut (2).

End By:

a. install tandem housings

[Previous Screen](#)

Product: MOTOR GRADER

Model: 120H ES MOTOR GRADER 6NM

Configuration: 120H Motor Grader 6NM00001-UP (MACHINE) POWERED BY 3116 Engine

Disassembly and Assembly

120H & 135H MOTOR GRADERS POWER TRAIN

Media Number -SEN8543-02

Publication Date -01/09/2004

Date Updated -25/08/2009

SEN85430009

Final Drives

SMCS - 4050-010; 4050-015; 4050-016

Remove & Install Final Drives

Start By:

- a. remove tandem drive housings

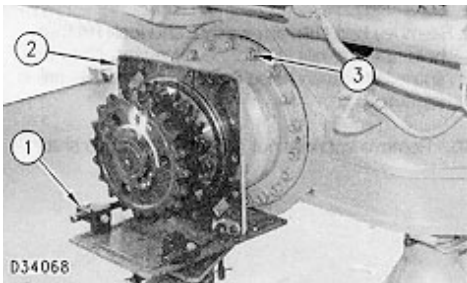

1. Install O.T.C. 1790 Transmission Jack (1) as shown. Secure the jack to final drive (2).

NOTE: It may be necessary to use forcing screws to loosen final drive (2) from the bevel gear case.

2. Remove nuts and washers (3) from the final drive flange.

3. Remove final drive (2) from the bevel gear case. Remove the O-ring seal from the back side of the final drive flange.

NOTE: The following steps are for installation of the final drives.

4. Check the condition of the O-ring seal that is used behind the back side of the final drive flange. If the seal is damaged, use a new part for replacement.

5. Install the O-ring seal in the back side of the final drive flange.

6. Install final drive (2) on O.T.C. 1790 Transmission Jack (1). Position final drive (2) to the bevel gear case.

7. Install nuts and washers (3) to the final drive flange. Tighten the nuts to a torque of 240 ± 40 N·m (177 ± 30 lb ft).

End by:

- a. install tandem drive housings

Disassemble Final Drives

Tools Needed		A
6V-2156	Link Brackets	2

Start By:

- a. remove final drives

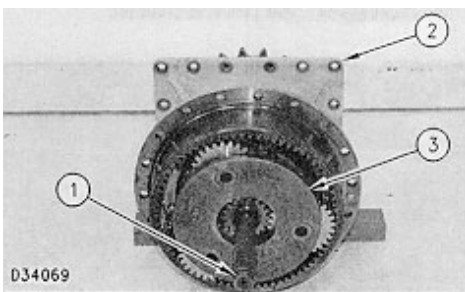

1. Remove sun gear shaft (1) from tandem housing assembly (2).
2. Remove planet carrier assembly (3) from tandem housing assembly (2).

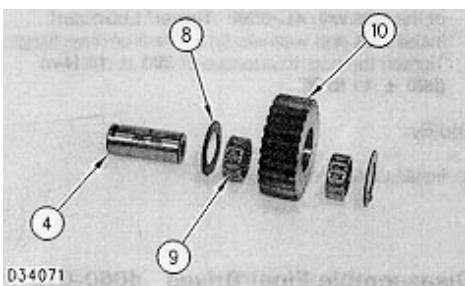
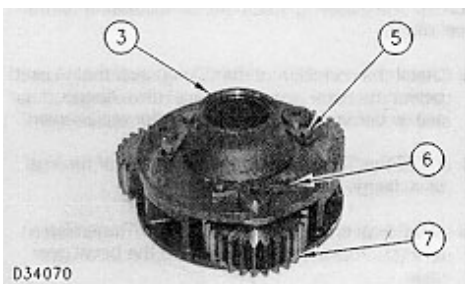

3. Remove six bolts (5), the washers and three retainers (6) from the planet carrier assembly (3).
4. Remove three shafts (4) in order to remove three gear assemblies (7) from the planet carrier assembly (3). Note the location of the components of the gear assemblies for assembly purposes.

5. Each gear assembly (7) consists of two washers (8), two bearings (9), gear (10) and shaft (4).

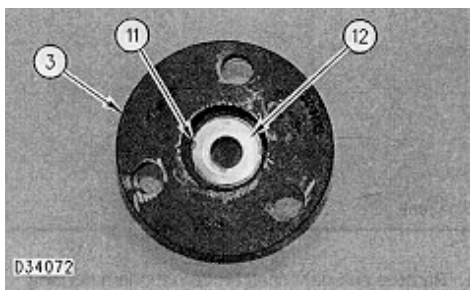

6. Remove retaining ring (11) and washer (12) from planet carrier assembly (3).

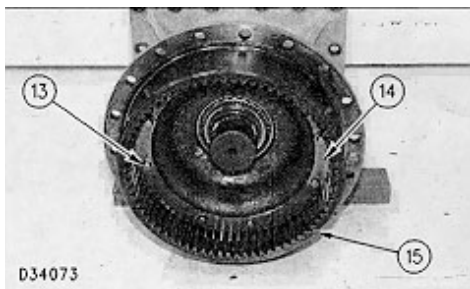

7. Remove eight bolts and washers (13) and four plates (14) in order to remove ring gear (15).

8. Remove ring gear (15) from tandem housing assembly (2).

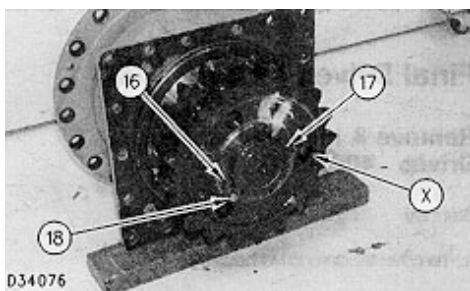

9. Remove bolt (18), the washer and lock (16) that hold spanner nut (17) to the drive shaft. Note that the spline lubrication holes (X) in both sprockets are in alignment.

10. Remove spanner nut (17) from the drive shaft.

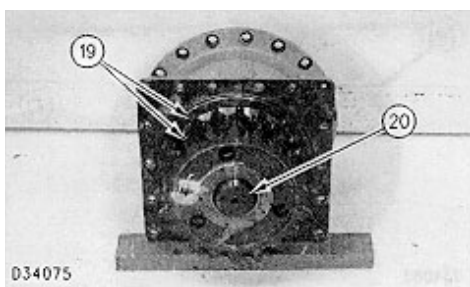

11. Remove two sprockets (19) from drive shaft (20). The weight of each sprocket is **15 kg (33 lb)**.

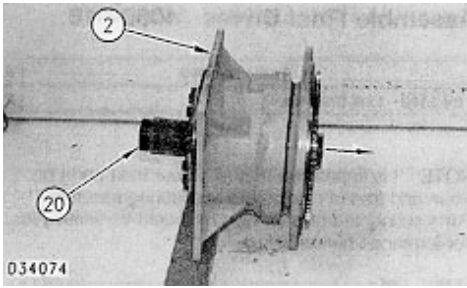

12. Remove drive shaft (20) and two bearing cones from tandem housing assembly (2). One bearing cone will come out with shaft (20). The remaining bearing cone has to be removed from the other end of tandem housing assembly (2). This will be done during Step 23.

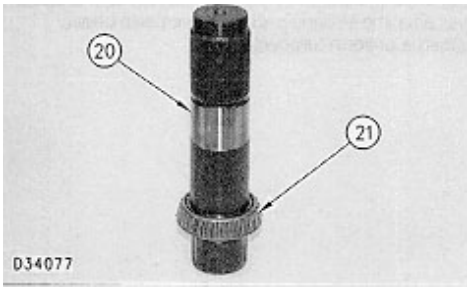

13. Remove bearing cone (21) from the drive shaft (20).

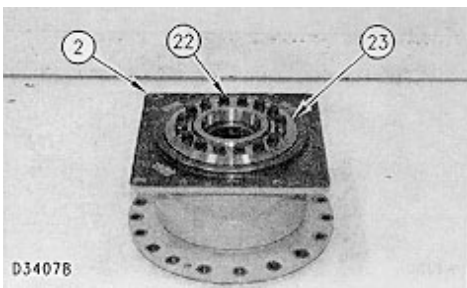

14. Remove 16 bolts and washers (22), retainer (23) and the shim pack (not shown) from tandem housing assembly (2).

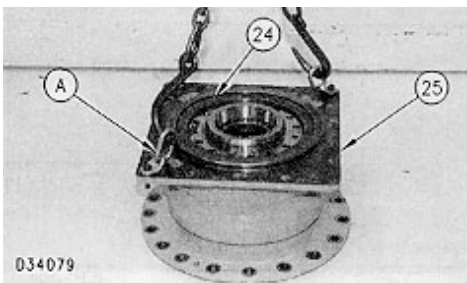

15. Install Tooling (A) and a hoist to tandem housing assembly (25).

16. Remove thrust washer (24) from tandem housing assembly (25).

17. Remove the housing from tandem housing assembly (25).

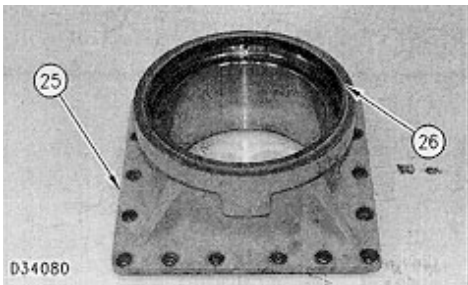

18. Remove lip seal (26) from tandem housing assembly (25).

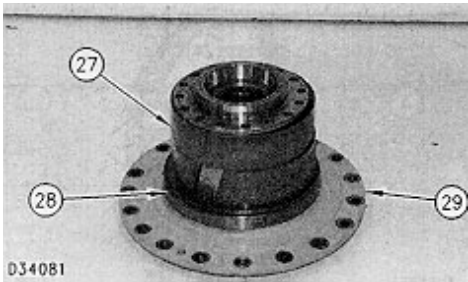

19. Remove two wear rings (27) from housing (29).

20. Remove thrust washer (28) from housing (29).

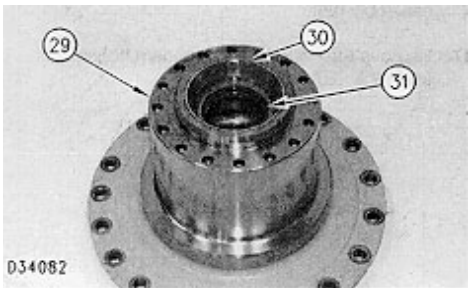

21. Remove bearing cup (30) from housing (29).

22. Remove lip seal (31) from housing (29).

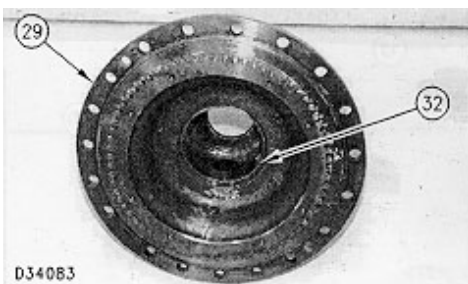

23. Remove inner bearing cup (32) from housing (29).

Assemble Final Drives

Tools Needed		A
6V-2156	Link Brackets	2

NOTE: It is imperative that all power train parts be clean and free of rust before and during assembly. Parts suspected of poor quality should be verified for conformance before using.

NOTE: Do not use preheating of bearing cones or precooling of bearing cups when you assemble the final drive unit in a shop. Use a suitable power press to install the cones on shafts and cups in the housing bores.

NOTE: Preheating or precooling of bearing cones or cups may be used to aid assembly where a power press is not available. Limit the heating of the cones to **135° C (275° F)** for no more than one hour. It is important to reseat the cone or the cup with a suitable driver after the bearing and adjacent parts have reached a uniform temperature.

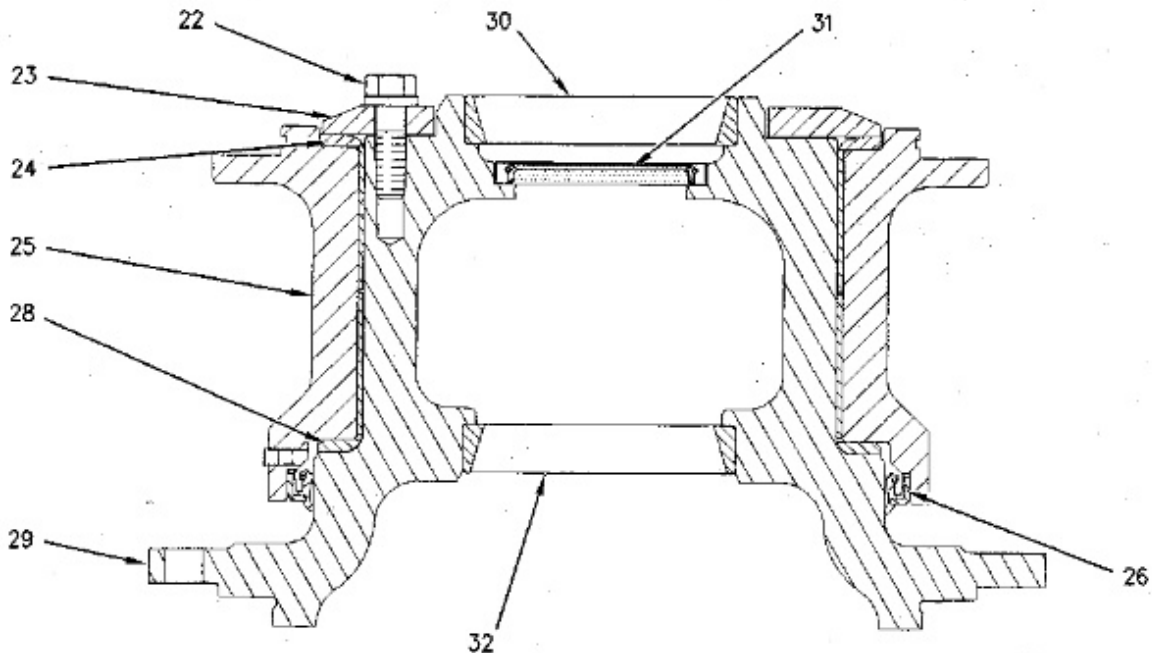

D34766

Tandem Housing Assembly

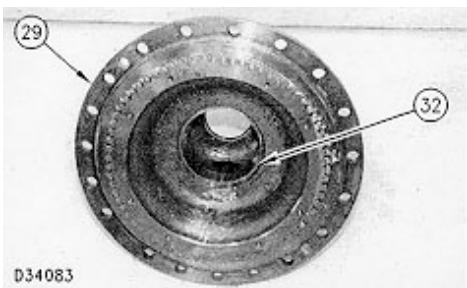

1. Lower the temperature of bearing cup (32) and install it in housing (29). Check for full seating of the cup with a **0.0005 mm (.0002 in) Feeler Gage**.

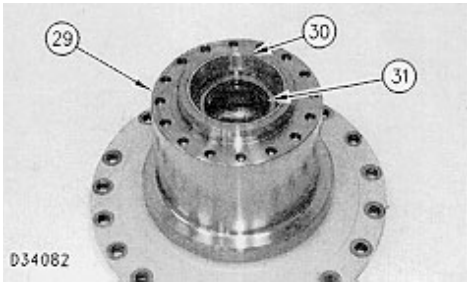

2. Place housing (29) in vertical position with the flange down. Install lip seal (31) in housing (29). The lip of the seal must face outward. Lubricate the sealing lip with the lubricant being sealed.

3. Lower the temperature of bearing cup (30) and install it in housing (29). Check for full seating of the cup with a **0.0005 mm (.0002 in) Feeler Gage**.

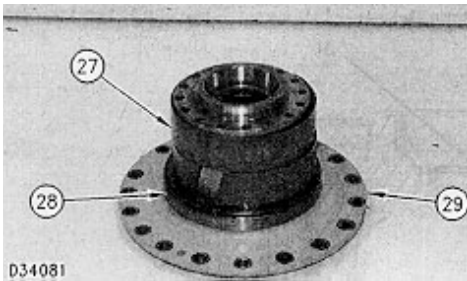

4. Coat the surfaces of thrust washer (28) with **6V-4876 Lubricant** and install it on housing (29).

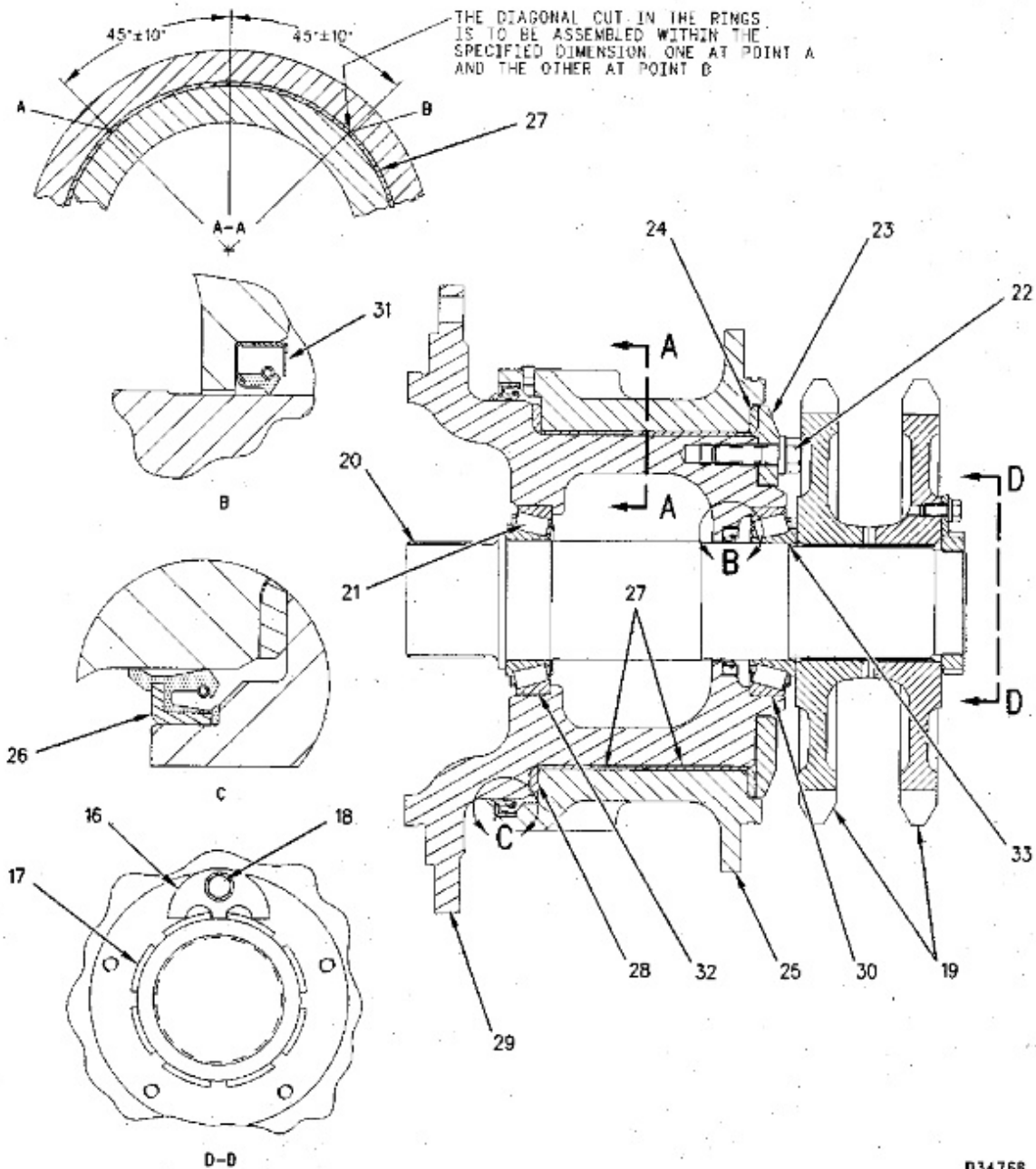

D34768

5. Coat the inner and outer surfaces of two wear rings (27) with **6V-4876 Lubricant** and install them on housing (29). The diagonal cuts in the wear rings must be located 90 degrees apart. Refer to the illustration **D34768** for an example of the locating positions.

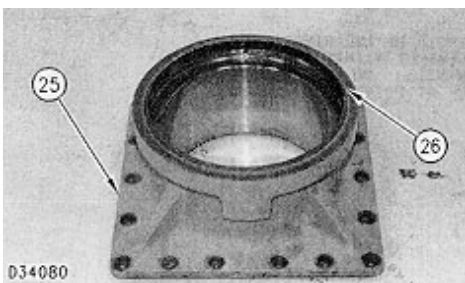

6. Install lip seal (26) in tandem housing assembly (25). The seal must be installed flush with the end of the tandem housing assembly (25). The sealing lip must face outward.

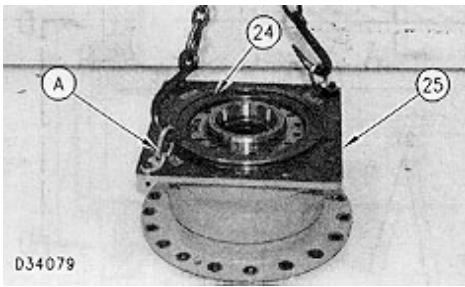

7. Install Tooling (A) and a hoist to tandem housing assembly (25). Carefully install tandem housing assembly (25) on the final drive assembly. Make sure wear rings (27) remain in the 90 degree location to each other.

8. Coat surfaces of thrust washer (24) with **6V-4876 Lubricant** and install it in tandem housing assembly (25).

NOTE: For rebuild of the oscillation joint, start with the same shim pack that was removed from the original assembly.

9. Install the shim pack and retainer (23) with the bolt holes aligned. Install 16 bolts and washers (22). Tighten the bolts to a torque of **270 ± 15 N·m (200 ± 11 lb ft)**. Use a dial indicator to check if the housing end play is within **0.0 to 0.060 mm (0.0 to .0025 in)**. Adjust the shim pack thickness and repeat the procedure if the end play is not within specification.

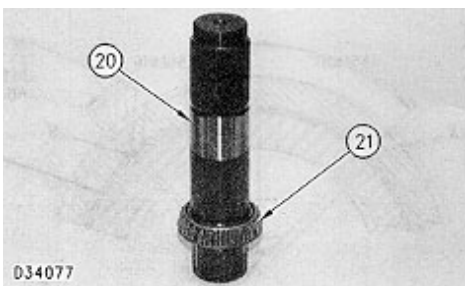

10. Preheat and install bearing cone (21) on shaft (20). Check for full seating of the cone with a **0.0005 mm (.0002 in) Feeler Gage**. With the shaft in a vertical position, set the tandem housing assembly down on bearing cone (21).

11. Start the second bearing cone on the top of shaft (20). **Do not** preheat this bearing cone. It can be seated in position by using the sprocket during step 12. Make sure that the bearing cone is seated in the cup.

12. Place the first sprocket on shaft (20). The large diameter must face downward.

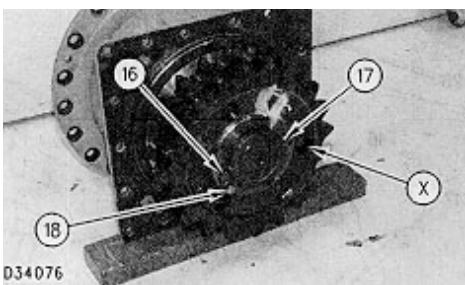

13. Place the second sprocket on shaft (20). The hub must face downward and the large diameter must face upward. Make sure that spline lubrication holes (X) are in alignment.



Suggest:

If the above button click is invalid.

Please download this document

first, and then click the above link

to download the complete manual.

Thank you so much for reading

14. Install the spanner nut and adjust the bearing preload.

a. Install spanner nut (17) to the drive shaft.

b. Rap the sprockets with a hammer while you rotate the shaft. Continue to turn the shaft. Tighten nut (17) in order to achieve a rolling torque of $7.9 \pm 1.1 \text{ N}\cdot\text{m}$ ($70 \pm 10 \text{ lb in}$).

c. Back nut (17) by one lockring position. Rap the sprockets in order to ensure that the bearings are seated properly.

d. Check the final rolling torque. The final rolling torque should be $2.3 \pm 1.1 \text{ N}\cdot\text{m}$ ($20 \pm 10 \text{ lb in}$). As required, adjust nut (17) in order to achieve the correct final rolling torque.

NOTE: The rolling torque in the Test & Adjust, "Final Drive Preload-Check" includes more components. The rolling torque is substantially higher. Do not confuse the two values for rolling torque.

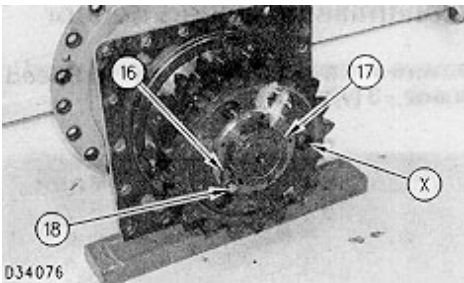

15. Install bolt and washer (18) and lock (16) that hold spanner nut (17) to the drive shaft. Tighten bolt (18) to a torque of $50 \pm 10 \text{ N}\cdot\text{m}$ ($37 \pm 7 \text{ lb ft}$).

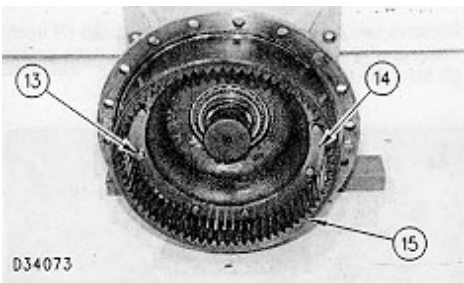

16. Place tandem housing assembly (25) in a vertical position, Place the sprockets on wooden blocks. Position ring gear (15) to tandem housing assembly (25).

17. Install eight bolts and washers (13) and four plates (14) in order to hold ring gear (15) to tandem housing assembly (25). Tighten bolts (13) to a torque of $50 \pm 10 \text{ N}\cdot\text{m}$ ($37 \pm 7 \text{ lb in}$).

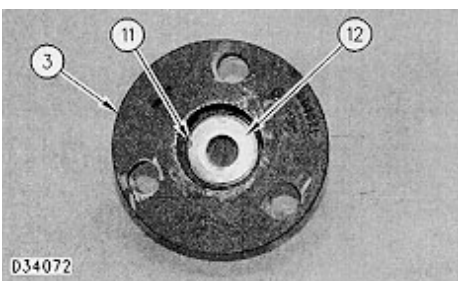

18. Install washer (12) and retainer (11) in planet carrier assembly (3).

<https://www.ebooklibonline.com>

Hello dear friend!

Thank you very much for reading.

Enter the link into your browser.

The full manual is available for immediate download.

<https://www.ebooklibonline.com>