WX210

WX240

HYDRAULIC EXCAVATOR

Service manual

Print No. 9-91270 English

SUMMARY

SAFETY INSTRUCTIONS	SECT. 0
TECHNICAL DATA AND SPECIAL TOOLS	SECT. 1
MACHINE STRUCTURE	SECT. 2
ELECTRICAL SYSTEM	SECT. 3
ELECTRONICS	SECT. 4
HYDRAULICS	SECT. 5
TROUBLESHOOTING AND REPAIR	SECT. 6
REPAIR INSTRUCTIONS	SECT. 7



Service manual

Section 0 Safety Instructions



WX210 - WX240

<https://www.ebooklibonline.com>

Hello dear friend!

Thank you very much for reading.

Enter the link into your browser.

The full manual is available for immediate download.

<https://www.ebooklibonline.com>

REPRODUCTION OF THESE OPERATING INSTRUCTIONS IN WHOLE OR
IN PART IS STRICTLY PROHIBITED EXCEPT WITH THE WRITTEN CONSENT
OF THE PUBLISHER

The data contained in this handbook were valid at the time of publication. As we constantly endeavour to improve our products and to provide additional options, modifications or changes made in this context may have an impact on the procedures described in this handbook. Please contact your local dealer if you find any discrepancies.

Table of contents

PREFACE	6
To the reader	6
Handling	6
Repair	6
Further information material	6
Warnings and symbols	7
Risks resulting from failure to observe the safety instructions	7
SAFETY INSTRUCTIONS	8
Personal safety instructions	8
Observe the safety instructions	8
Protection from noise	8
Preparing for emergencies	8
Wearing protective clothing	9
Safety instructions before starting work	10
Checking the machine	10
Keeping the working area clean	10
Using grab handles and steps	11
Adjusting the operator's seat	11
Applying the safety belt	12
Working from the operator's seat only	12
Never take passengers on the machine	12
Safety instructions for machine operation	13
Before setting off	13
Note the position of the working equipment	13
Taking care during operation	13
Taking care when trenching	14
Distance from overhead power lines	14
Accident Prevention when reversing and slewing	15
Rules for driving on the road	16
Recovering and towing the machine	16
Travelling uphill and downhill	17
Preventing the machine from overturning	18
Inspecting the deployment location	18
Parking the machine safely	19
Preventing accidents when the machine is moving	19
Confirming the direction of machine travel	19
Avoid caving out high banks	20
Protection from rockfall and landslides	20
Caving prevention	21
Never move the bucket above persons	21

Safety instructions, maintenance/servicing	22
Safety during transport.....	22
Safety during servicing operations.....	23
Warning instructions for servicing work	24
Correct machine support.....	24
Working at greater heights.....	25
Keeping clear of moving parts	25
Prestressed units	26
Never remove lead seals	26
Safety instructions for accumulators.....	26
Dismantling components.....	27
After repair work.....	27
Correct waste disposal.....	27
Welding operations	28
Starting the engine with starter batteries	29
Prevention of acid-induced burns	29
Prevention of scalding.....	30
Safe handling of fluids.....	30
Fire prevention	31
Evacuation in case of fire.....	32
Risks from exhaust gases.....	32
Risks from fluids in pressure systems.....	33
Preventing heat build-up close to pressure systems	34
Preventing heat build-up in lines carrying combustible fluids	34
Removing paint before welding.....	35
Risks from breaking-away components	36
Use appropriate tools	36
Warning and instruction signs	38
Organizational measures	42
Selection and qualification of personnel; basic responsibilities	43
Safety instructions governing specific operational phases	43
Warning of special dangers	45

PREFACE

40000000-en

To the reader

The Technical Manual (TM) has been written for the **repair specialist**. It provides important information on carrying out repair work expertly.

Please go carefully through the **Technical Manual** as well as the Owner's Manual for the **hydraulic excavator** before starting any repair work. Use the **Technical Manual** as well as the **Owner's Manual** and **spare-parts list** as a reference book and source of information even if you are familiar with hydraulic excavator technology.

Using the Technical Manual, the experienced construction machine mechanic can carry out any necessary repairs expertly.

Handling

The Technical Manual is divided into eight sections and covers the originally delivered version of the machine. Any additions or modifications undertaken at a later date are not described in this manual.

- Introduction
- Safety Instructions
- Technical Data and Special Tools
- Description of Functioning
- Performance Testing
- Troubleshooting
- Repair Instructions
- Annex

The **Safety Instructions** section describes the recommended procedures to be observed in order to prevent any risk of accidents to the operator and to the personnel responsible for the works and for machine servicing measures.

The **Description of Functioning** section provides technical information on operating the main devices and systems.

The **Technical Data and Special Tools** section lists service data, conversion tables and special tools and servicing materials required.

The **Performance Testing** section gives the information required for carrying out performance testing.

The **Troubleshooting** section contains information on detecting faults in the machine.

The **Repair Instructions** section gives the technical information needed to carry out servicing and repair work on the machine, describes the equipment needed for servicing works, and provides

information on maintenance standards, removal and installation procedures, and dismantling and assembly procedures.

The required information can easily be found by referring to the table of contents.

For reasons of clarity, some of the illustrations are presented in simplified form. Differences from the actual version at the hydraulic excavator are therefore possible if this adds to the clarity of the information.

Repair

Carry out any necessary repair work as soon as possible. This reduces repair costs and increases the availability of your hydraulic excavator.

When doing any work on the hydraulic excavator, always observe the instructions given in the Technical Manual and in the Owner's Manual.

Extensive works not described in the Technical Manual will gladly be executed for you by the O&K after-sales service.

Always use **original spare parts** only.

Further information material

Please consult the following documents in addition to this Manual:

- Owner's Manual
- Spare-parts catalogue



Warnings and symbols

The following signs are used in the Technical Manual to designate exceptionally important information:

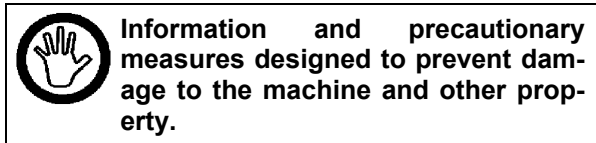
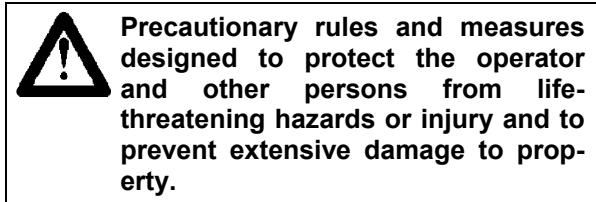

Risks resulting from failure to observe the safety instructions



This hydraulic excavator has been built in accordance with state-of-the-art standards and recognized safety regulations.

Nevertheless, its use may constitute a risk if it continues to be operated despite damage being suspected or having occurred, or if it is inexpertly repaired.

There is then a risk of

- life-threatening injury**
- irreparable damage to the machine and other assets.**

The hydraulic excavator must be stopped immediately if suspected damage or damage that has occurred affects the safety of the operator, other persons at the excavator deployment site, or other assets. All components are carefully coordinated. Trouble-free operation and a long service life are assured only if original spare parts are used.

□

SAFETY INSTRUCTIONS

4000004-en

Personal safety instructions

Observe the safety instructions



- Read carefully through all safety instructions attached to the machine and observe them; read all safety instructions in this manual in addition.
- Safety instruction stickers/plates must be affixed, maintained and replaced when necessary.
- If a safety instruction sticker/plate or this manual is damaged or missing, obtain a replacement from your dealer. The procedure is the same as when ordering spare parts (it is essential to quote the machine type and the serial number).
- Familiarize yourself with the correct, safety-oriented procedure for operating the machine and its control elements.
- Allow only trained, qualified and authorized persons to operate the machine.
- Keep the machine in good working order.
- Unauthorized modifications to the machine may affect its efficiency and/or safety and reduce its service life.
- The instructions given in this Safety Instructions section are designed to show the fundamental safety procedures for the machine. However, they cannot cover all hazardous situations with which you may be confronted. If in doubt, consult your immediate superior before operating the machine or carrying out servicing work.

Protection from noise



- Sustained effects of noise may lead to impaired hearing or deafness.
- Wear appropriate ear protectors such as earplugs or muffs for protection from disturbing or intolerable noise.

Preparing for emergencies



- Be prepared for the event of a fire breaking out or an accident occurring.
- Keep the first-aid box and the fire extinguisher readily accessible at all times.
- Read the instructions for operating the fire extinguisher and learn how to use it properly.
- Stipulate emergency procedures for the event of fire or accidents.
- Keep the emergency numbers of doctors, emergency services, hospitals and the fire service in the immediate vicinity of the phone.



Wearing protective clothing



Wear close-fitting clothing and protective equipment suited to the work.

You need:

- a safety helmet
- safety footwear
- goggles or face guard
- protective gloves
- ear protectors
- reflective clothing
- waterproof clothing
- respirator or filtering mask.

Ensure that you wear the right equipment and clothing for the job.

- Never take risks.
- Never wear loosely fitting clothing, jewellery or other objects that might get caught on operating levers or other machine components.

Safe operation demands the operator's complete attention. Never wear headphones to listen to the radio or to music while operating the machine.



Safety instructions before starting work

4000008-en

Checking the machine



Before starting up the machine each day or before each shift, give the outside of the machine a careful visual inspection to prevent damage and injury.

- Check the machine for superficial damage.
- Check before starting work that all covers and caps are closed and locked.



Fig. 1

Keeping the working area clean



Clean the working area before starting work.

- Remove any objects that might endanger the mechanics or persons in the working area.
- Keep your cab clean and cleared; loose items may disturb the machine operation.

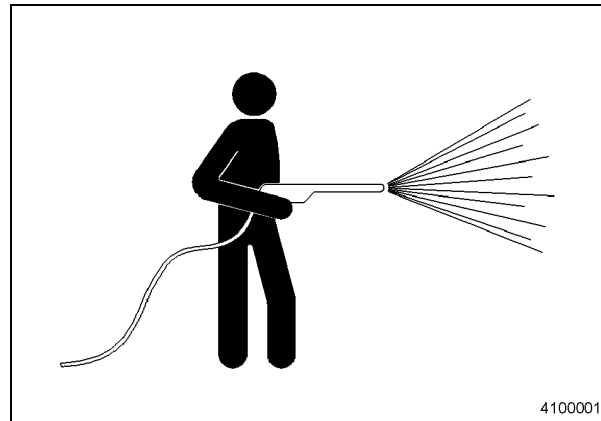



Fig. 2



Using grab handles and steps



Falls are one of the main causes of injury.

- Always face the machine when entering or leaving it, and use only the aids provided, e.g. steps and handrails.
- Never use operating elements as grab handles.
- Never jump down from the machine.
- Never climb up onto or down from a moving machine.
- Watch for slippery platforms, steps and handles when leaving the machine.

Adjusting the operator's seat



A seat that is poorly adjusted with respect to the operator or the working conditions may result in premature operator fatigue and thus in faulty operation.

- The seat must be adjusted with any change of machine operator.
- The operator must be able to depress the pedals completely and move the control levers effortlessly with his back resting against the backrest.

If that is not possible, move the seat forward or back and check the setting again.

Consult the relevant section in the Owner's Manual.

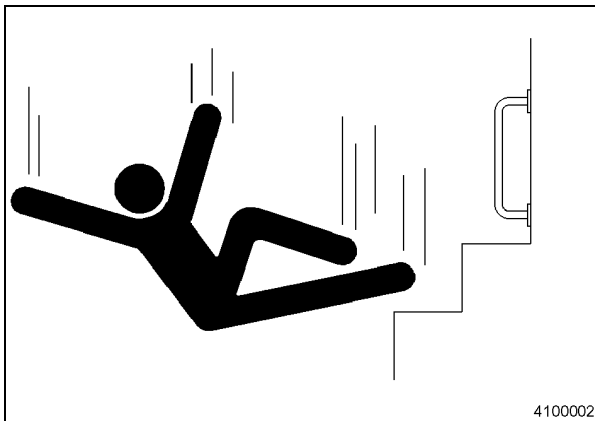

4100002

Fig. 3



4100003

Fig. 4



Applying the safety belt



If the machine overturns, the operator may be injured and/or thrown out of the cab. He may be severely injured or even crushed to death by the overturning machine.

- Before operating the machine, check the belt fabric, the closure and the fastening components carefully. If one of the parts is damaged or worn, replace the safety belt or the components before starting up the machine.
- Always remain seated and keep the safety belt fastened while operating the machine. This will help minimize the risk of injury in the event of an accident.

The safety belt must be replaced after any serious accident even if it appears to be undamaged.

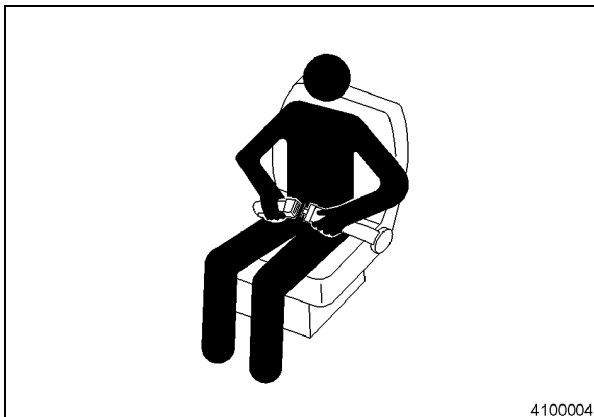

4100004

Fig. 5

Working from the operator's seat only



Starting up the engine incorrectly may cause the machine to make unexpected movements that might lead to severe, even fatal, injury.

- Always start up the engine from the operator's seat only.
- Never start the engine by short-circuiting the starter.
- After starting up the engine, check that all driving levers, driving pedals and control levers are in neutral position.

Never take passengers on the machine



Passengers on the machine may suffer injury e.g. from foreign bodies or through being thrown off.

- Only the operator is allowed onto the machine. Never take passengers.
- Passengers also obstruct the operator's view so that the machine is no longer safely operated.

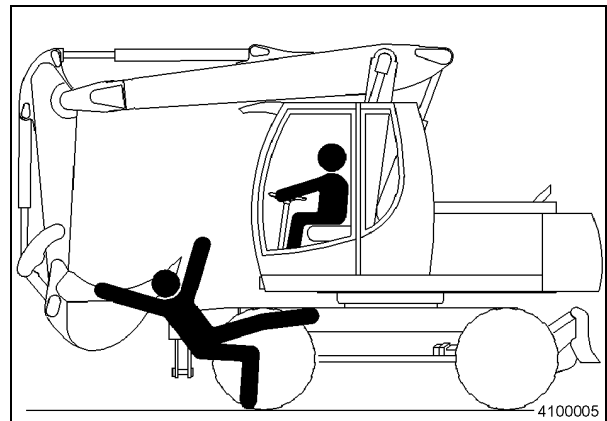

4100005

Fig. 6



Safety instructions for machine operation

4000022-en

Before setting off



Remove any soil, mud, snow, ice, grease and oil from your working footwear before operating the machine. You might otherwise slip from steps and pedals and thus initiate inadvertent movements.

Adjust the driver's seat and the mirror before setting off.

Close the front window and the cab door.

If the machine is equipped with a restraining belt for the operator, fasten the belt.

Before setting off, sound the horn to warn any persons in the immediate vicinity.

Never allow other persons to travel with you on the machine.

Taking care during operation



If the front equipment or another part of the machine collides with a higher obstacle, e.g. a bridge, both the machine and the other object are damaged, and persons may be injured.

Take care to prevent the boom or stick from colliding with higher obstacles.

Note the position of the working equipment



Never drive with the working equipment extended, as that may impair the stability of the machine. Bring the working equipment as close as possible to the machine.

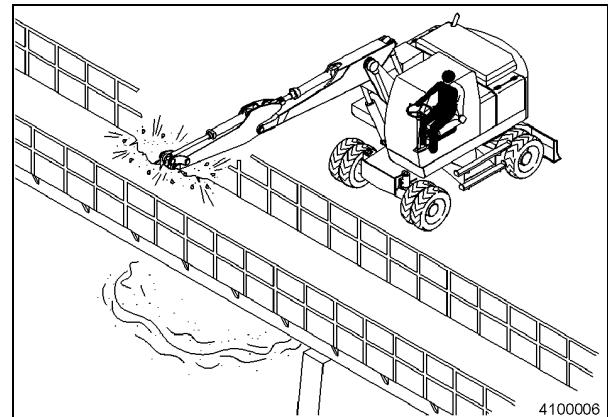

Fig. 7



Taking care when trenching



The inadvertent severing of underground cables or gas pipes may cause an explosion and / or fire. This may result in severe, potentially fatal injury.

- Before doing any trenching work, check the course of cables, gas pipes and water pipes.
- Observe the statutory minimum distance from cables, gas pipes and water pipes. Never look into the end of an inadvertently severed fibre-optics cable, as that may severely injure the eyes.

Contact the local authorities and / or supply enterprises (electricity, gas, water, sewage, telecommunications etc.) to obtain information on underground supply lines.

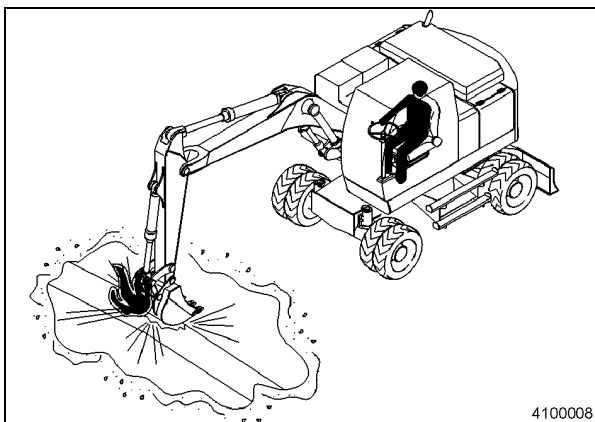

4100008

Fig. 8

Distance from overhead power lines



Severe, potentially fatal injury may result from the machine or the front equipment not being kept well clear of overhead power lines.

- If work is being done close to an overhead power line, no part of the machine or the load must come within a distance of 3 m plus twice the length of the overhead power line insulator from the power line.
- Check out and observe the relevant local regulations.
- Wet ground increases the range in which a person may get an electric shock.
- Keep all persons or colleagues clear of the location.

After contacting live wires

- Do not leave the machine.
- Drive the machine out of the hazard zone. Warn others against approaching and touching the machine.
- Have the live wire de-energized.

Do not leave the machine until the contacted / damaged line has been de-energized with absolute certainty.

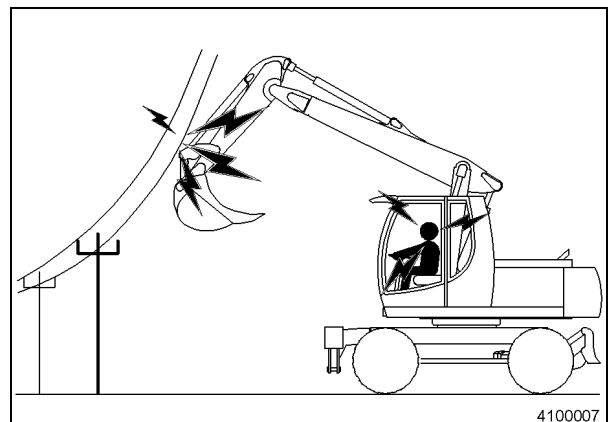

4100007

Fig. 9



Accident Prevention when reversing and slewing

 Any person in the immediate vicinity of the machine may be hit or run over when the machine is being reversed or the superstructure is being slewed. This may result in severe, potentially fatal injury.

To prevent accidents during reversing and slewing:

- Enlist the assistance of a marshaller if your view is restricted.
- Always look in all directions before reversing or slewing. Make sure there is no one in the immediate vicinity.
- Keep the acoustic reversing alarm (if present) in a good operating state.
- Always be prepared for the possibility of persons entering the hazard zone. Use the horn or another signal to warn any persons in the immediate vicinity.
- Enlist a marshaller for reversing if your view is restricted. Always ensure that the marshaller is within sight.
- The machine must not be moved until agreement has been reached with the marshaller on correct interpretation of the signals.
- Familiarize yourself with the meaning of all markings, signs and designations used in the operation and come to an agreement on them with the marshaller.

 - Keep windows, mirrors and headlamps clean and in good order.

- Dust, heavy rain, fog, etc. may reduce visibility. If this is the case, reduce your speed and switch on appropriate lighting.

Read the Owner's Manual carefully.

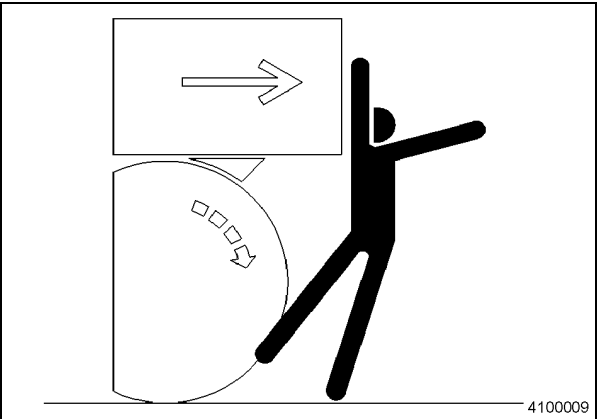

Fig. 10

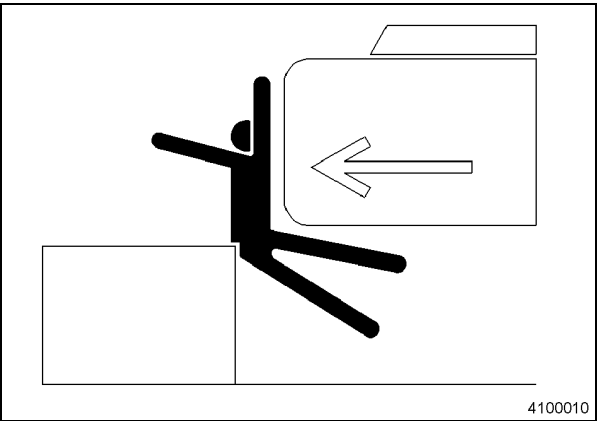

Fig. 11



Rules for driving on the road



The machine must not be driven on the public highway unless the conditions of the "General Operating Permit" are observed or, in the event of deviations from the "General Operating Permit", a vehicle-specific operating permit has been granted. These permits must be present in the cab during such travel.

- Always have a warning triangle, warning lamp and first-aid kit on board.
- Bring the working equipment into a position in which the maximum machine dimensions are not exceeded.
- Switch the bucket/grab switchover valve to "Grab" position. The bucket cylinder is then hydraulically blocked.
- Mount clearance lamp on stick and connect to a socket.
- Raise levelling blade completely and attach a reflector.
- Raise claws (option) completely and block mechanically.
- Switch off floodlamps.
- Lock superstructure..

Recovering and towing the machine



Tow the machine with a tow-rod or towing rope only.

The tow-rod or rope must be free from damage. They must be dimensioned in such a way that the calculated breaking load is equal to three times the tractive power of the towing machine.

The towing vehicle must have adequate tractive power.

Drive slowly, carefully and smoothly.

All persons must keep clear of the tow-rod or rope.



- Tow only if the brakes and the steering of the machine are functioning properly and if the machine cannot be otherwise transported.

- Tow defective machines only as far as necessary to recover the machine from hazardous areas.

- After the recovery, the machine must be secured against inadvertent movements and unauthorized starting.

- Have the machine repaired before transporting it over greater distances, or load it onto a transport vehicle.

- The machine is not suitable for towing trailers or other vehicles over longer distances; this would result in damage to axles and gearboxes. The tow coupling is designed solely for towing or recovering vehicles from hazardous areas or for lashing purposes on transport vehicles.



Travelling uphill and downhill



Before starting up the machine, read through the Owner's Manual carefully.

- Before driving the machine, put it into neutral position (see Owner's Manual).
- Never drive down slopes with a gradient of more than 30°. Take an alternative route with lower gradients.
- Keep the bucket 20 - 30 cm above the ground on the uphill side while travelling uphill or downhill.
- If the machine starts to slip or to lose its stability, lower the bucket immediately.
- Driving across slopes may cause the machine to slip or overturn.
- Steering manoeuvres on slopes may cause the machine to overturn.
- Never coast downhill. This may result in a loss of control over the vehicle and in severe damage to property as well as fatal injury.
- Always change to first gear before the downhill / uphill slope. This increases the brake action of the travel motor, preventing inadmissibly high travel speeds.
- When working on a slope, the fuel tank must be topped up as soon as the fuel indicator lights up.

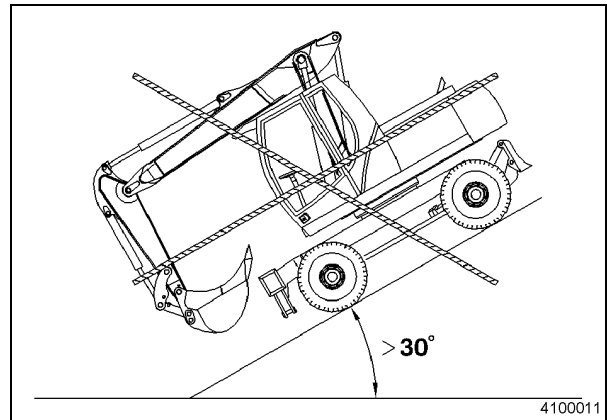

Fig. 12

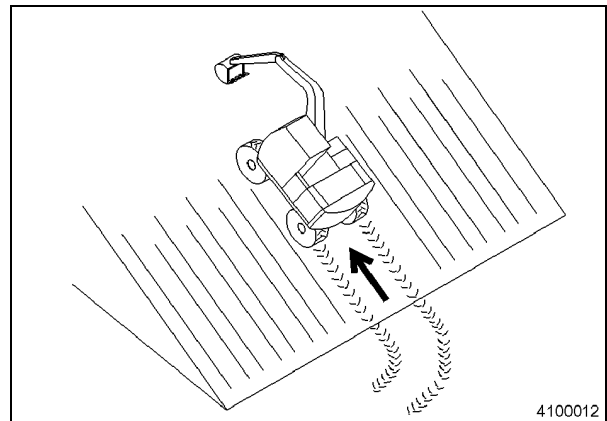

Fig. 13

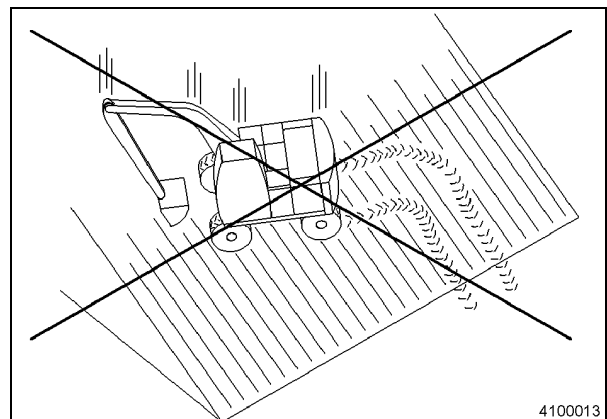

Fig. 14



Preventing the machine from overturning



Working on slopes always entails a risk of the machine overturning. This may result in severe, potentially fatal injury.

To prevent overturning:

- Exercise special care when working on a slope.
- Prepare the working area of the machine by levelling it.
- Keep the bucket close to the ground and to the machine.
- Reduce the working speed of the machine to prevent overturning or slipping.

Avoid changing direction when driving on a slope.

- Always try to avoid crossing a slope with a gradient of more than 5 degrees.
- When slewing a load, reduce the slewing speed to meet safety requirements.

Special care must be taken when working on frozen ground.

- A rise in temperature softens the soil, impairing the stability of the machine during travel.

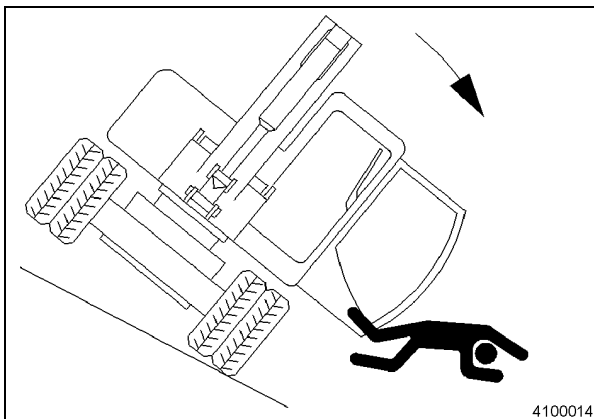

4100014

Fig. 15

Inspecting the deployment location



Working at the edge of excavations or on the verge of a road entails a risk of the machine overturning. This may result in severe, potentially fatal injury.

- Before starting work, inspect the site and the ground conditions to prevent any risk of the machine overturning and of the ground, a stockpile or a wall giving way.
- If necessary, the ground, excavation site edges and verges must be reinforced. Keep sufficient clearance with the machine from the edges of the excavation site and the verges.
- When working on a slope or on the verge of a road, enlist the services of a marshaller if necessary.
- If the ground has a poor load-bearing potential, reinforce it before starting work.
- Special attention is needed when working on frozen ground. If the ambient temperature rises, the ground becomes soft and slippery.

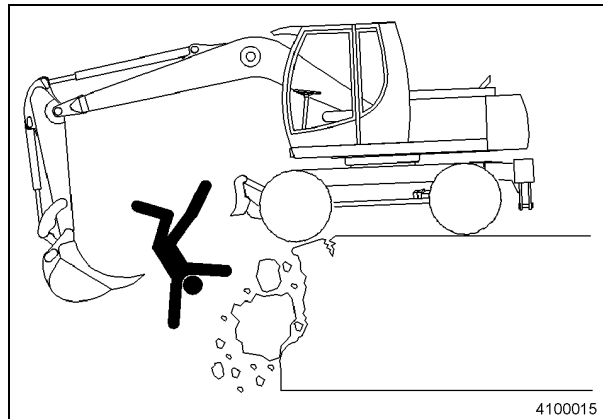

4100015

Fig. 16



Parking the machine safely



To prevent accidents:

- Park on a flat, horizontal surface.
- Turn the brake switch to braking position.
- Set the working equipment down on the ground.
- Lower the levelling blade and/or the outrigger claws onto the ground.
- Engage the superstructure lock.
- Run the engine unloaded at minimum speed for ca. 5 minutes.
- Turn the ignition key to OFF position to switch off the engine. Then withdraw the key.
- Move the steering safety lever to block the machine.
- Lock the windows, the sliding roof and the cab door.
- Lock all covers and flaps.

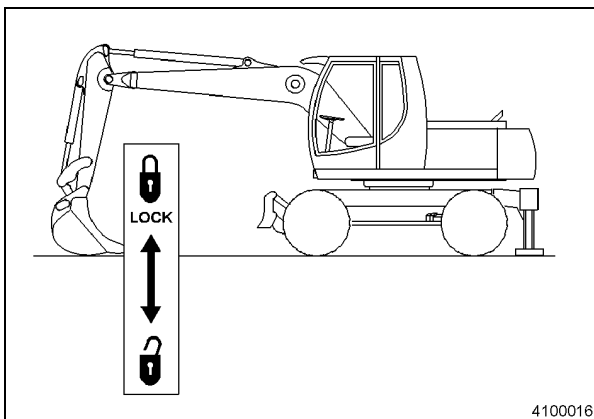

4100016

Fig. 17

Preventing accidents when the machine is moving



Severe or fatal accidents may result from an attempt to enter or leave a moving machine.

- Before leaving the operator's seat, select a flat, horizontal area for parking if possible.
- Park the machine safely.
- Block both wheels and set the working equipment down on the ground.
- Park at a reasonable distance from other vehicles.

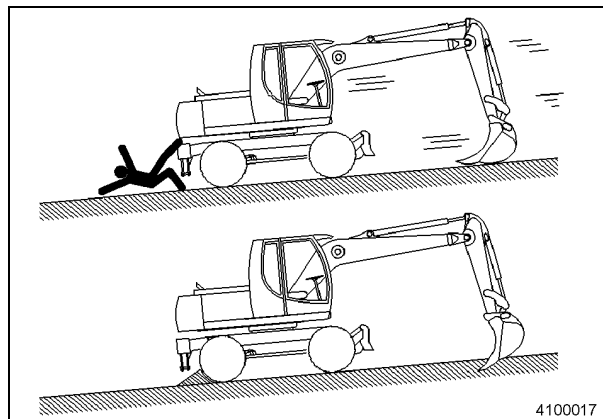

4100017

Fig. 18

Confirming the direction of machine travel



Inadvertent activation of the operating pedal may result in severe damage or fatal accidents.

Check the machine position. Read the corresponding section in the Owner's Manual.



Avoid caving out high banks

 **The edges may cave in or there may be a landslide. This can result in severe, potentially fatal injury.**

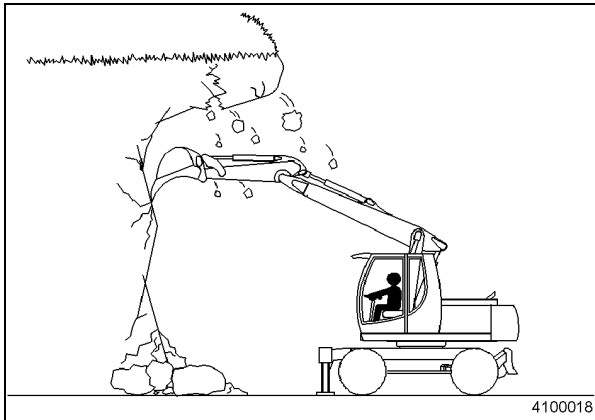



Fig. 19

Protection from rockfall and landslides

 **Before working at locations with a risk of rockfall, make sure your machine has a Falling Object Protective Structure (FOPS).**

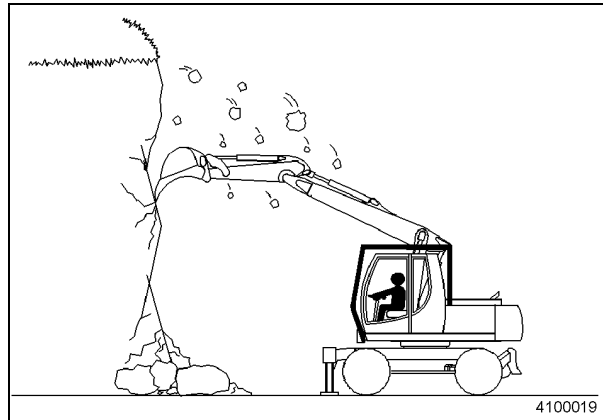



Fig. 20



Caving prevention

 To reverse away from the edge of an excavation in the event of the ground giving way, the tracks must always be positioned with the rear travel motors at right angles to the edge of the excavation.

Do not panic if the ground starts to give way and adequate withdrawal is impossible. In such cases the machine can often be secured by lowering the front equipment.

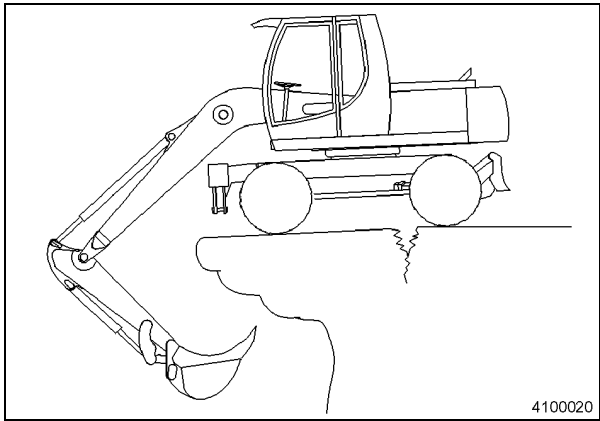



Fig. 21

Never move the bucket above persons

 The bucket must never be lifted, moved or slewed above persons or a truck cab.

Material falling from the bucket or a collision with the bucket may result in injury and in damage to the machine.

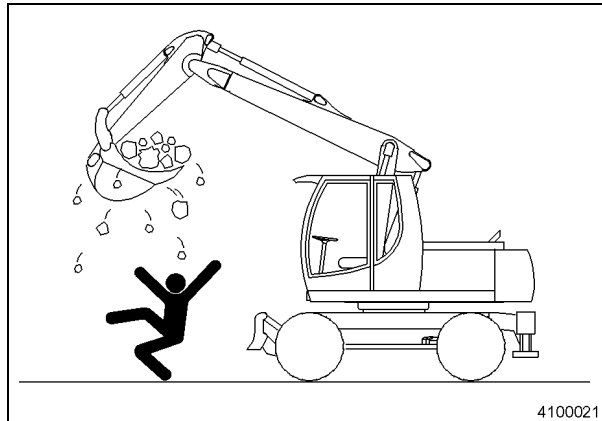

Fig. 22

□

Safety instructions, maintenance/servicing

4000024-en

Safety during transport



There is a risk of the machine overturning when it is being loaded onto a truck or trailer and when it is being unloaded.

- Ensure that local regulations are observed when the machine is being transported on the public highway.
- An appropriate truck or trailer must be provided for the transport of the machine.

When loading/unloading the machine, the following precautions must be taken:

- Find firm, horizontal ground.
- Always use a loading platform or drive-on ramp.
- A marshaller must be enlisted to help with loading/unloading the machine.
- When loading or unloading the machine, the automatic speed reset must always be switched off to prevent an unexpected increase in speed due to inadvertent activation of an operating lever.

Always set the transmission stage switch to "slow".

In the "fast" transmission stage, the travelling speed may be automatically increased.

- Avoid steering movements when driving up or down the ramp, as that is extremely dangerous. If steering is absolutely essential, first drive back onto the ground or the loading area, correct the driving direction, and set off again.



- At the top end of the ramp, which adjoins the loading area, there is a joint. Drive over it with care.
- When slewing the superstructure, avoid fast movements as they might cause the machine to overturn, resulting in potential injury.
- Keep the stick retracted and turn the superstructure slowly to ensure maximum stability.
- Secure the machine frame with chains or cables.

Details are given in the appropriate sections of the Owner's Manual.

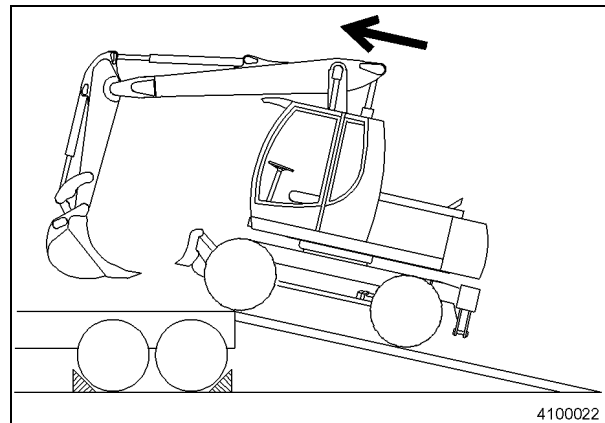

Fig. 23



Safety during servicing operations



To prevent accidents:

- Before starting work, familiarize yourself with the servicing procedure.
- Keep the working area clean and dry.
- Never perform any lubrication or servicing work while the machine is in motion.

Before carrying out servicing work on the machine:

- Park the machine safely.
- Never leave the machine unsupervised if servicing work has to be carried out with the engine running.
- If the machine has to be raised, the boom and stick must be positioned at an angle of 90° - 110°. Secure the machine components that have to be raised for servicing or repair work with appropriate supports.
- Work must never be done under a raised machine that is supported by the boom.

Certain components have to be checked at regular intervals and repaired or replaced if necessary. Details are given in the corresponding sections of the Owner's Manual.

- Use original spares only.
- All components must be kept in a good state and correctly installed. Any defect must be repaired immediately.
- Any damage must be rectified immediately. Worn or non-functioning components must be replaced. Remove any lubricating grease, oil and dirt deposits.



Disconnect the cable from the negative pole of the battery before doing any work on the electrical system or arc welding on the machine.



4100023

Fig. 24

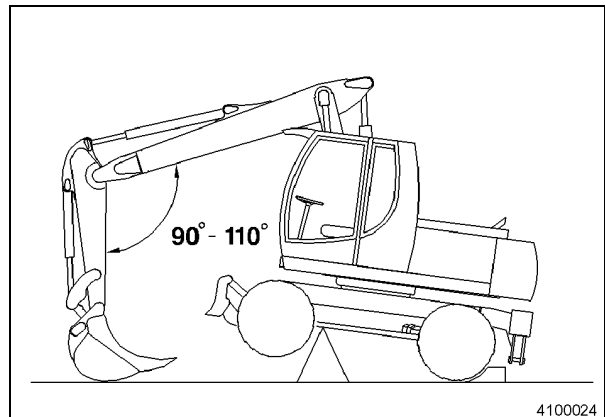

4100024

Fig. 25



Warning instructions for servicing work



Unexpected machine movements may result in serious injury.

- Prior to doing any work on the machine, display a notice "Servicing work in progress" to ensure that the machine is not used inadvertently.

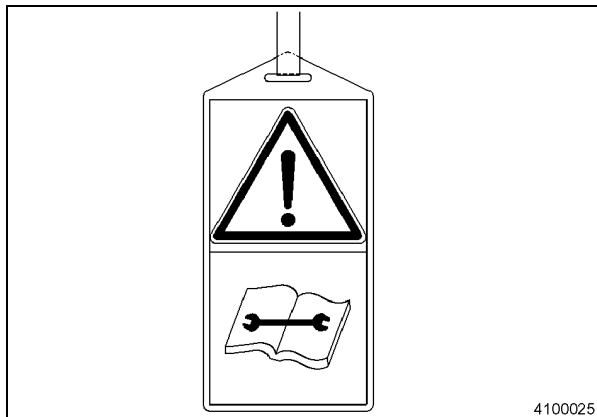



Fig. 26

Correct machine support



Never carry out work on the machine without first securing it.

- Always lower the working equipment or the tool onto the ground before working on the machine.
- If you have to work on a raised machine or raised working equipment, stabilize the machine or working equipment with a support.
- The machine must not be supported with hollow blocks, tyres or supports that give way when continuously loaded.
- Never work under a machine that is supported with lifting gear only.

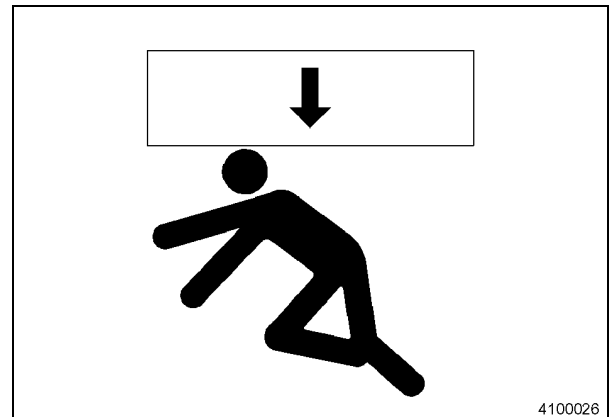

Fig. 27



Working at greater heights

 **Always wear a safety harness when working at greater heights.**
Wear an approved safety harness; it must be equipped with stabilizers and safety cables.

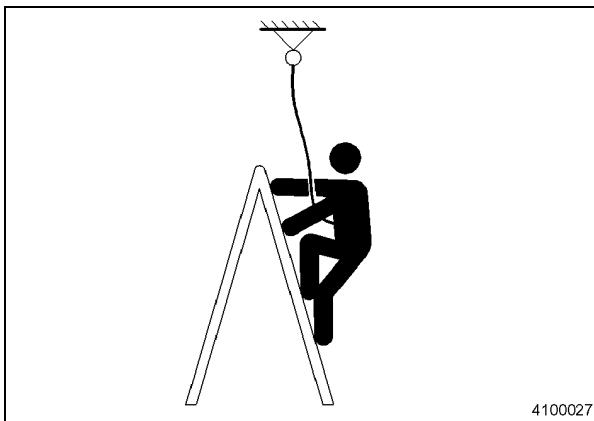



Fig. 28

Keeping clear of moving parts

 **Catching in moving parts may result in severe injury.**
To prevent accidents, care must be taken to ensure that hands, feet, clothing, jewellery and hair cannot get caught in moving parts when work is being done close to them.

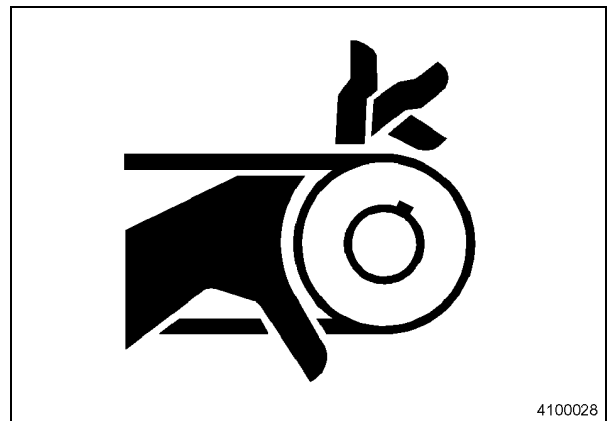

Fig. 29



Prestressed units



Never open defective prestressed systems but replace the entire system.

Open only in exceptional cases, when the system and the operational sequence are exactly known and the necessary special tools are available.

Never remove lead seals



Never change the rated pressure of pressure-reducing valves without the explicit authorization of the manufacturer.

Never remove lead seals from pressure-reducing valves and accumulators.

Safety instructions for accumulators



Accumulators are installed in the hydraulic system. They contain nitrogen under high initial pressure.

Even when the hydraulic system has been depressurized, the nitrogen pressure is maintained in the accumulator.

The accumulators are completely safe in operation. If incorrectly handled, however, there is a risk of explosion.

The accumulators installed in this machine cannot be repaired. Defective accumulators must be replaced.

Never handle accumulators mechanically, never weld or solder them.

Before dismantling the accumulator, put on goggles and working gloves, and depressurize the hydraulic system.

Use original spares only. If in doubt, contact your local agent or the after-sales service.

Never remove or paint over warning and information plates, rating plates or type identification markings. Replace illegible or damaged plates immediately.





Suggest:

If the above button click is invalid.

Please download this document

first, and then click the above link

to download the complete manual.

Thank you so much for reading

Dismantling components



Never dismantle while the machine is still at operating temperature.

Oils, greases, brake fluid or coolant may have a high temperature and thus result in burning or scalding.

Wait for the machine to cool down.

Depressurize pipelines and hoses, cylinders, radiator, hydraulic tank, compressed air reservoir and other systems or units before starting work.

Replace defective components in good time to prevent greater damage.

Clean the defective component carefully before dismantling it.

Mark dismantled components in the correct sequence to facilitate installation.

When dismantling the component, close exposed hose and pipe connections, open boreholes and housings with care to prevent dirt from penetrating.

After repair work



To prevent corrosion, coat all bright metal machine components with a grease film.

On completing the work, reassemble all protective devices, covers, and sound- and vibration-insulation material.

Never start up the driving motor while work is being done on the machine.

Check the repaired components and all machine functions with a trial run.

Never release the machine for re-commissioning until it is fully functioning.

Correct waste disposal



Incorrectly discarded waste is an environmental hazard. Hazardous substances used in excavators include lubricants, fuels, coolants, brake fluids, filters and batteries.

- Use sealed containers to discard fluids. Never use containers designed for food or drinks.
- Never discard waste onto the ground, into drains or into water.

Ask your local authorities, collection points or dealer about the correct procedure for recycling or discarding waste.



<https://www.ebooklibonline.com>

Hello dear friend!

Thank you very much for reading.

Enter the link into your browser.

The full manual is available for immediate download.

<https://www.ebooklibonline.com>