

# W26 SERIES B LOADER

## TABLE OF CONTENTS

SERIES/SECTION	SECTION NO.	FORM NO.
10 SERIES - GENERAL		
Maintenance and Lubrication .....	IX	9-71015
General Engine Specifications .....	1010	9-77195
Detailed Engine Specifications .....	1020	9-76875
20 SERIES - ENGINES		
Stall Checks and Engine Removal .....	1A	9-71015
Engine Diagnosis .....	2001	9-76365
Engine Tune-Up .....	2002	9-76379
Cylinder Head, Valve Train and Camshaft .....	2015	9-76166
Cylinder Block, Sleeves, Pistons and Rods .....	2025	9-76176
Crankshaft, Main Bearings, Flywheel and Oil Seal Replacement .....	2035	9-76187
Lubrication System .....	2046	9-76805
Cooling System .....	2055	9-76337
Turbocharger Failure Analysis .....	2565	9-78235
30 SERIES - FUEL SYSTEM		
Fuel System and Filters .....	3010	9-75297
Robert Bosch Fuel Injection Pumps .....	3012	9-74937
Roosa Master Fuel Injectors .....	3013	9-74959
40 SERIES - HYDRAULICS		
Hydraulic System .....	VI	9-71015
50 SERIES - STEERING		
Steering System .....	VII	9-71015
60 SERIES - POWER TRAIN		
Transmission and Torque Converter Removal and Installation .....	III A	9-71015
Allison Powershift Transmission Service Manual .....		SA 1104G
Differential and Planataries .....	IV	9-71015
70 SERIES - BRAKES		
Brakes and Air Operated Accessories .....	V	9-71015
80 SERIES - ELECTRICAL		
Electrical System .....	II	9-71015
90 SERIES - MOUNTED EQUIPMENT		
Loader .....	VIII	9-71015

**SECTION IX  
MAINTENANCE  
AND  
LUBRICATION**

## **TABLE OF CONTENTS**

SERIAL NUMBER LOCATIONS .....	3
MAINTENANCE CHART .....	4-6
LUBRICANT CHART .....	6
LUBRICATION POINTS .....	7
FUEL SPECIFICATIONS .....	8
DRY TYPE AIR CLEANER .....	9
AIR CLEANER SERVICE INDICATOR .....	11
TRANSMISSION FILTER, STRAINER AND BREATHER SERVICING .....	12
U.S. AND METRIC TORQUE SPECIFICATIONS .....	13

**<https://www.ebooklibonline.com>**

Hello dear friend!

Thank you very much for reading.

Enter the link into your browser.

The full manual is available for immediate download.

**<https://www.ebooklibonline.com>**

## SERIAL NUMBER LOCATIONS

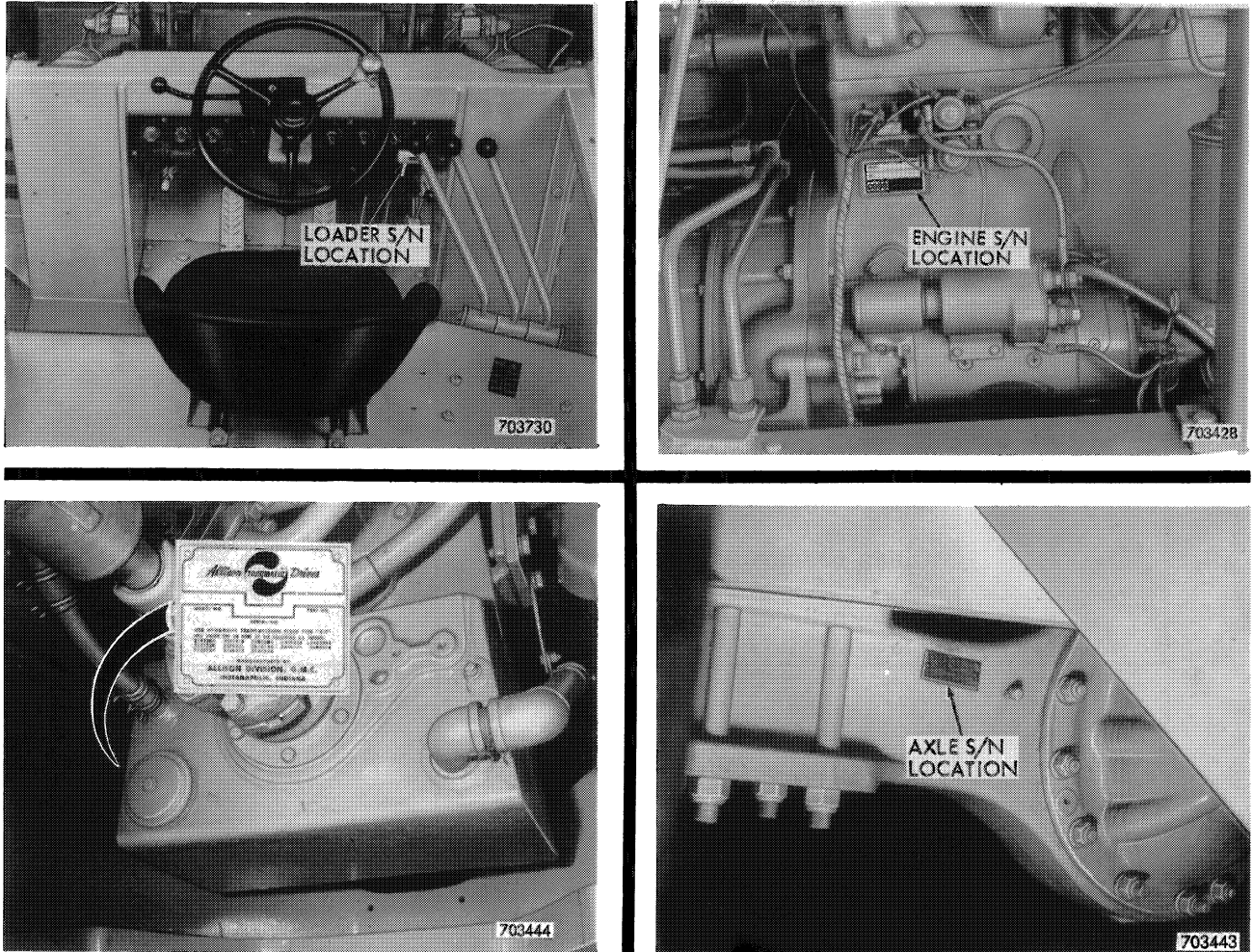

Figure 1

### Component Serial Numbers

These vendor items have serial number plates:

1. Alternator
2. Starter
3. Hydraulic equipment pump
4. Steering Control Valve

5. Equipment Control Valve
6. Demand Valve (Optional)

### Right Hand And Left Hand

The terms "right hand" (RH) and "left hand" (LH), used throughout this manual, are determined by standing at the rear of the unit and facing in the forward direction of travel.

## MAINTENANCE CHART

INTERVAL	TYPE OF SERVICE	FLUIDS & LUBRICANTS
Run-In Every 2 Hours	Check wheel bolt torque until stabilized. Torque 380 to 420 foot pounds. (Dry threads)	
Run-In After first 20 hours	Change engine oil. Replace engine oil filter. Change hydraulic oil. Replace hydraulic oil outlet filters (3). Clean reservoir breather Clean hydraulic oil inlet screen	See Chart, page 6  Case TCH fluid
Every 10 hours or daily	Grease the loader pivot points Check engine oil level Drain water from main air reservoir Drain water from auxiliary air reservoir Check radiator coolant level	See Chart, page 6
Every 60 hours or weekly	Grease rear axle trunnion pivots Grease upper and lower hinge pins Grease steering cylinders Check hydraulic oil level Check transmission oil level Check battery electrolyte level Lubricate brake pedals Drain water from 1st stage fuel filter	See Chart, page 6 See Chart, page 6 See Chart, page 6  Distilled water Few drops engine oil.

INTERVAL	TYPE OF SERVICE	FLUIDS & LUBRICANTS
Every 100 hours	Change engine oil Grease all drive line grease fittings and plugs.	See Chart, page 6 See Chart, page 6
Every 200 hours	Grease pitman arm link Grease foot throttle cross shaft Replace engine oil filter Check brake master cylinders (3) fluid level	See Chart, page 6 See Chart, page 6 SAE J1703 fluid
Every 500 hours	Check front and rear axle oil level Check steering gear box oil level Check fan belts and air compressor drive belt tensions Change hydraulic oil Replace hydraulic oil outlet filters (3) Clean reservoir breather Clean hydraulic oil inlet screen Drain water from fuel tank	Case TCH fluid
Every 1000 hours	Clean transmission breather Clean transmission oil screen Replace transmission oil filter Change transmission oil Drain and clean cooling system Change front and rear axle oil Remove air compressor cylinder head and clean (by Case dealer only)	Case TCH fluid See Chart, page 6

INTERVAL	TYPE OF SERVICE	FLUIDS & LUBRICANTS
Every 2000 hours	Remove, inspect, service and clean the turbo supercharger (by Case dealer only)	
Every 3000 hours	Rebuild or replace air compressor (by Case Dealer only)	
As required	Clean air cleaner filter element when indicator red band is showing  Replace fuel filters when gauge enters red zone  Remove and clean fuel tank filler screen	

### LUBRICANT CHART

LUBRICATION POINTS	CAPACITY		RECOMMENDED LUBRICANT
	U.S.	LITERS	
Engine crankcase (without filter change) Engine crankcase (with filter change)	12 qts. 13 qts.	11,3 12,3	Engine oil meeting the following specifications: Service DS; Series 3 & MIL-L-45199.  Above 32° F. . . . . SAE 30 10° F. to 50° . . . . . SAE 20W Below 32° F. . . . . SAE 10W
Transmission and Converter	5-1/2 gal.	20,8	Case TCH Fluid
Hydraulic reservoir	31 gal.	117,3	Case TCH Fluid (See Note)
Steering gear housing Front axle Rear axle	2-1/2 pt. 42 pts. 40 pts.	1,2 19,9 18,8	Multipurpose gear lubricant SAE 90 (AP1-GL-4, MIL-L-2105B)
Grease fittings	Use as required		Above 32° F.    Multipurpose or No. 1 lithium—soap base grease  Below 32° F.    Multipurpose or No. 2 lithium—soap base grease

**NOTE:** Alternate oil - Motor oil meeting API service designation MS or DG; non foaming. Use SAE 10W above 32° F. and SAE 5W below 32° F.

## LUBRICATION POINTS

If the loader is operated in severe or abnormal conditions, lubricate more often. Wipe all fittings clean before greasing. Clean grease must be maintained in all pivot points to assure long bearing life.

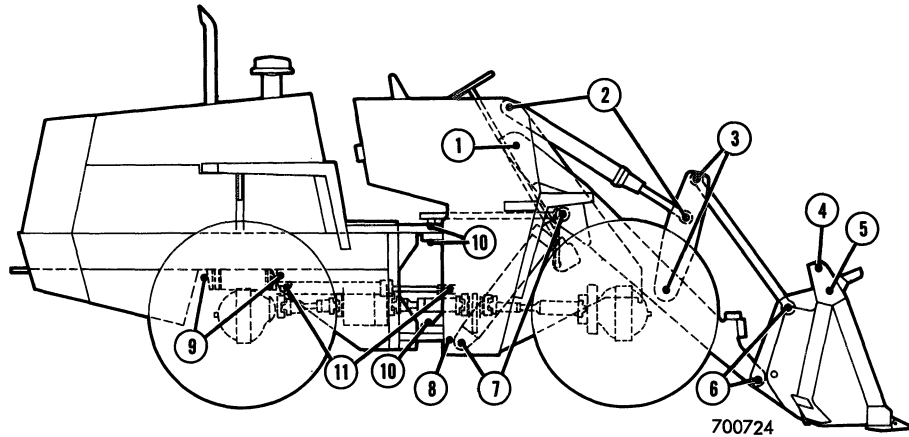

Figure 2

### Every 10 Hours

- |    |                                     |                                   |
|----|-------------------------------------|-----------------------------------|
| 1. | Lift arm pivots .....               | (2) One each side                 |
| 2. | Tilt cylinders .....                | (9) Four LH side and five RH side |
| 3. | Tilt linkage .....                  | (10) Five each side               |
| 4. | Drott clam cylinder (rod end) ..... | (2) One each side                 |
| 5. | Drott clam pivot .....              | (2) One each side                 |
| 6. | Bucket pivot points .....           | (12) Six each side                |
| 7. | Lift cylinder .....                 | (6) Three each side               |
| 8. | Lift cylinder cross shaft .....     | (1) One in the middle             |

### Every 60 Hours

- |     |                                 |   |
|-----|---------------------------------|---|
| 9.  | Rear axle trunnion pivots ..... | (2) One each end                              |
| 10. | Chassis center pivot .....      | (3) Two on upper pivot and one on lower pivot |
| 11. | Steering cylinders .....        | (4) One each end of each cylinder             |

### Every 100 Hours

- |                                       |                         |
|---------------------------------------|-------------------------|
| Universal joints .....                | (6) One each joint      |
| Front drive line center bearing ..... | (1)                     |
| Drive line splines .....              | (3) One plug each shaft |

### Every 200 Hours

- |                                 |                   |
|---------------------------------|-------------------|
| Pitman arm link .....           | (2) One each end  |
| Foot throttle cross shaft ..... | (2) One each side |

# FUEL

## Diesel Fuel

### Recommended Fuel

Case diesel engines are designed to operate most efficiently with No. 2 diesel fuel. Most well known refiners and distributors market a good grade of diesel fuel and there should be no difficulty in obtaining it.

Do not confuse No. 2 diesel fuel with No. 2 furnace oil which is similar but does not always meet specifications for diesel engines.

**CAUTION:** No. 1 diesel fuel is not recommended for normal operating conditions. This is a lighter fuel which can result in loss of engine power, increased fuel consumption, and lessened injection pump life.

### Fuel Specifications

There can be considerable variation in diesel fuels marketed as No. 2. The American Society for Testing Materials (ASTM) has established a widely recognized specification, ASTM Designation D975, which is used in the United States, Canada, and many other areas of the world. Any fuel purchased for use in a Case engine should meet this ASTM specification.

However, there is no world-wide standardization of diesel fuels and ASTM specifications are not used everywhere. Following are the most important specifications of an acceptable diesel fuel:

Pour point, maximum . . . . .	10° F. below lowest atmospheric temperature at which engine must start and operate.
Cetane number, minimum . . . . .	40 (45-55 for winter or high altitudes).
Sulphur, by weight, maximum . . . . .	.50 of 1%
Water and sediment, by volume, maximum . . . . .	.05 of 1%
Ash, by weight, maximum . . . . .	.01 of 1%
Carbon residue on 10%, maximum . . . . .	.20 of 1%
Distillation, 90% point . . . . .	540° - 625°
End point . . . . .	675°
Flash point, minimum . . . . .	125° or legal
Viscosity, centistokes at 100° F. . . . .	2.0 - 4.3
Saybolt Universal Seconds at 100° F. . . . .	32 - 40
Corrosion, copper strip, 3 hours at 212° F. . . . .	No. 3 ASTM
API gravity, minimum . . . . .	30

700313

## DRY TYPE AIR CLEANER

The air cleaner must be serviced when the red band is in full view on the air cleaner service indicator.

### Servicing Primary Element

Refer to Figure 4.

Washing is the preferred method of cleaning the element as it removes more dust and soot, thus restoring the element to an almost new condition.

Wash the filter in Case Filter Element Cleaner, Part No. A40910. Mix according to instructions on container. Do not use water pressure over 40 PSI at the nozzle. Let the element dry completely before installing. Do not use air pressure to dry the element.

The element can be cleaned with compressed air although it is not recommended because it will not remove carbon and soot. Do not use air pressure in excess of 100 PSI at the nozzle. Place the element on a clean

flat surface, then place a cover (wood or metal) with a small opening over the top of the element. Place nozzle in opening in cover. Blow element clean, starting with low air pressure and gradually increasing it.

Inspect the element after it is clean and dry as shown in Figure 3.

Rotate the filter around the light and check for damage and pin holes. Check the gasket for defects. Inspect the metal covering for dents. Any dent in the covering is a potential puncture, in that the paper element will rub the dent and a hole will result. Elements with holes or indications of fuzz must be replaced. Replace gasket if it is found to be defective. Do not accept a new filter or install a new or used filter if the metal covering is dented.

The filter should be replaced after it has been cleaned six times or once a year (1000 hours), whichever occurs first. When servicing the air cleaner, make sure all connections are air tight. Air cleaner efficiency is directly dependent upon air tight connections.

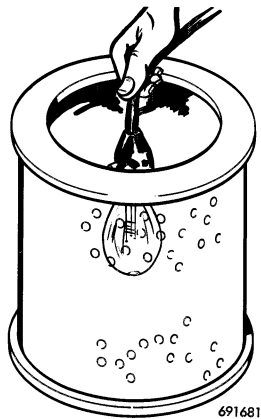
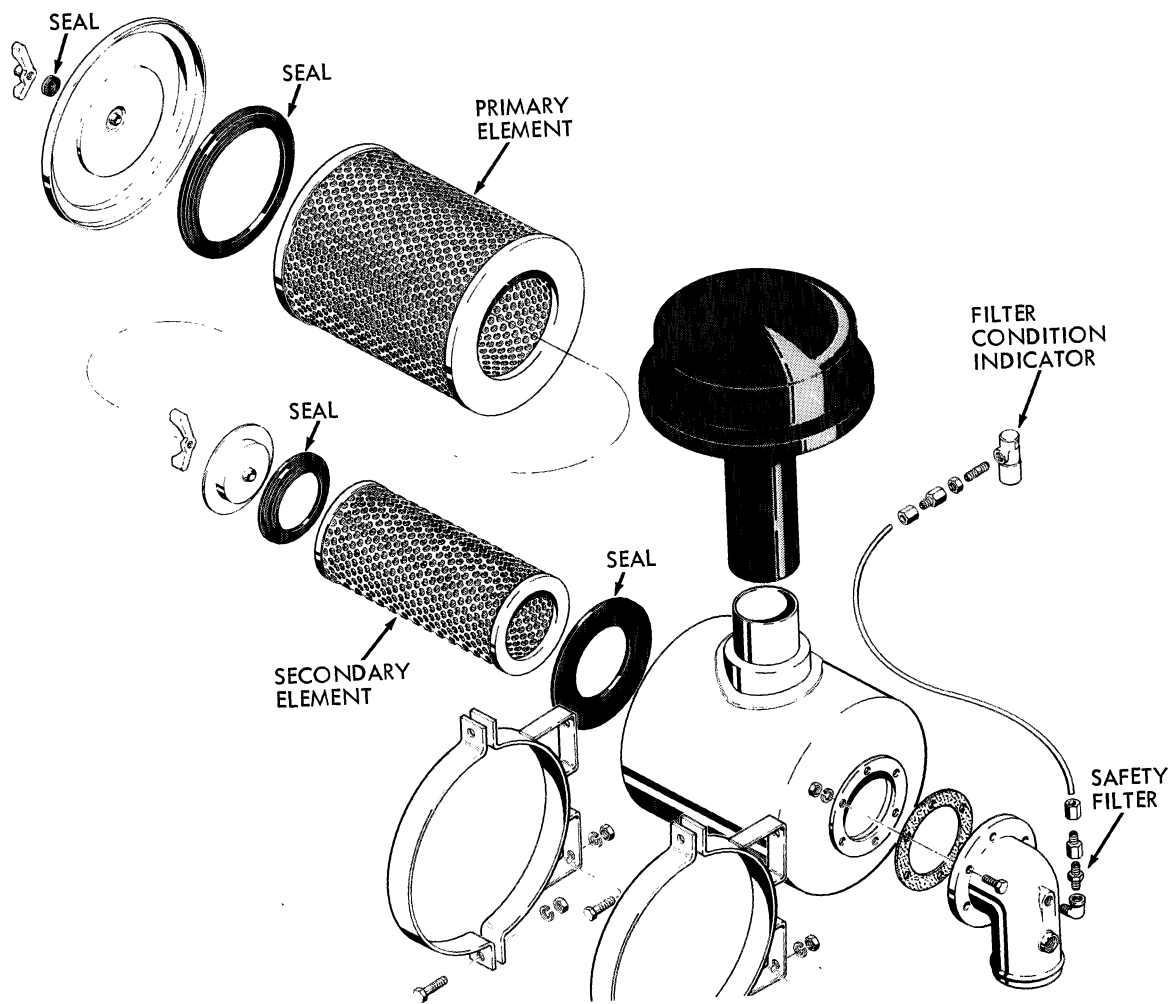

Figure 3

### Servicing Secondary Element

Cleaning the secondary element is not recommended except in an emergency. If the element is cleaned it should be replaced as soon as possible. Check the secondary element for replacement as follows: Install cleaned or new primary filter element and start engine. Observe air cleaner service indicator. If the red signal is still in full view on the service indicator the secondary filter element must be replaced immediately.



700821

Figure 4 - Air Cleaner

## AIR CLEANER RESTRICTION INDICATOR

### Specifications

Case No. . . . . L-40280  
Manometer Test  
Inches of water . . . . . 20"

### Trouble Shooting

Refer to Figure 4. The restriction indicator is mounted to the front of the rear chassis.

1. The restriction indicator is serviced as an assembly only. It is non adjustable.
2. If restriction indicator troubles are suspected, first check out the safety filter.
3. Check fittings for tightness. Check the tube and fittings for visible damage.
4. If a distributor tester equipped with a manometer is available, the restriction indicator can be tested as follows:
  - a. Remove the condition indicator from the engine and attach the manometer hose to indicator.
  - b. Turn on the tester. Turn the tester vacuum regulator control on and slowly increase the vacuum until the red signal band is in full view. The signal band should be in full view at 20" of water.
  - c. If the restriction indicator does not meet this specification, it should be

replaced. The indicator is nonadjustable.

### Safety Filter

A safety filter is built into the connector which joins the tube from service indicator to the air intake line. This filter prevents unfiltered air from entering the engine, if the tube to the service indicator or the service indicator itself becomes damaged.

The safety filter will plug up with continued operation if a leak occurs. When the filter becomes plugged the service indicator will fail to operate.

### Checking For Plugged Safety Filter

1. Remove the air cleaner cap and seal off the air cleaner intake opening.
2. Start the engine. If the red signal band in the restriction indicator fails to appear, the safety filter is plugged and must be serviced.

### Servicing Safety Filter

1. Disconnect the tube from the restriction indicator at the connector. Remove the connector and safety filter.
2. Try to clean the filter with compressed air. If it cannot be cleaned, replace the fitting with the filter. Repeat the test above to make sure problem is corrected.

## TRANSMISSION FILTER, STRAINER, AND BREATHER SERVICING

Service Interval . . . . . Every 1000 hours

### Removal And Service

**TRANSMISSION OIL STRAINER** - Remove drain plug and strainer and gasket. Discard gasket. Clean the strainer in cleaning solvent.

**NOTE:** Do not install drain plug and strainer until the oil filter and breather have been serviced. This procedure is recommended to allow maximum oil drainage.

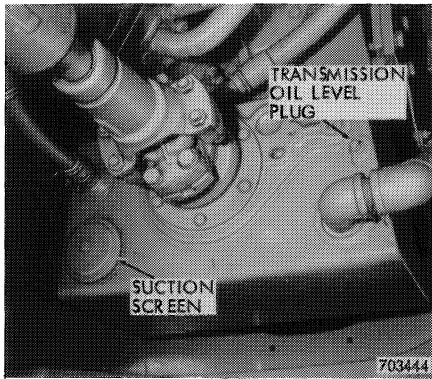

Figure 5 - Transmission Oil Strainer

**TRANSMISSION BREATHER** - Remove breather and clean in cleaning solvent. Reinstall breather. If the breather appears to be damaged it must be replaced.

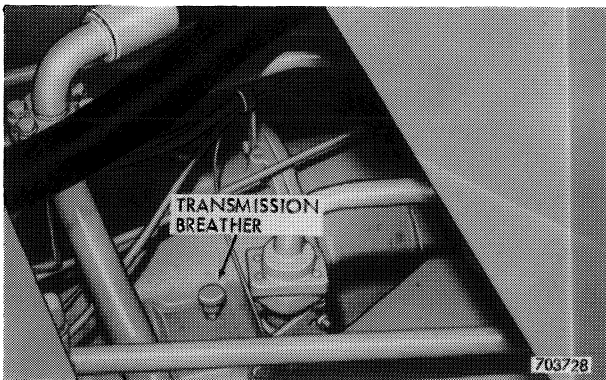

Figure 6 - Transmission Breather

**TRANSMISSION OIL FILTER** - To remove the filter element, loosen the cover retaining clamp bolts and remove clamp, cover with relief valve, gasket and filter element. Discard gasket and filter element. Remove the remaining oil from the filter case with a hand suction gun. Clean the inside of the filter case with a lint free cloth. Install a new filter element and gasket. Reinstall cover and retaining clamp and tighten.

After servicing the oil filter, reinstall the drain plug and strainer with a new gasket. Fill transmission with 5-1/2 gallons of new Case TCH Fluid. Start engine and run at idling speed for a few minutes to fully charge the transmission and converter. Check oil level as instructed in Transmission Section. Check for oil leaks.

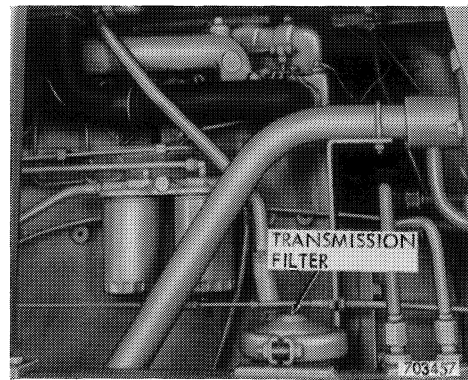





Figure 7 - Transmission Oil Filter



## U.S. AND METRIC TORQUE SPECIFICATIONS

Torque values for all situations unless special torque is specified.

### Grade 5 Bolts, Nuts, Studs (Dry)

Thread Size	Torque			Thread Size	Torque	
	ft. lbs.	m-kg			ft. lbs.	m-kg
1/4" - 20 NC	5-10	0,7-1,4		3/4" - 10 NC	235-285	32-39
1/4" - 28 NF	10-15	1,4-2,1		3/4" - 16 NF	270-330	37-46
5/16" - 18 NC	15-20	2,1-2,8		7/8" - 9 NC	360-440	50-61
5/16" - 24 NF	15-20	2,1-2,8		7/8" - 14 NF	395-490	55-68
3/8" - 16 NC	25-35	3,5-4,8		1" - 8 NC	520-640	72-88
3/8" - 24 NF	30-40	4,1-5,5		1" - 12 NF	575-705	79-97
7/16" - 14 NC	45-55	6,2-7,6		1-1/8" - 7 NC	720-820	99-113
7/16" - 20 NF	50-60	6,9-8,3		1-1/8" - 12 NF	790-970	109-134
1/2" - 13 NC	65-85	9,0-12,0		1-1/4" - 7 NC	1010-1240	139-171
1/2" - 20 NF	80-100	11-14		1-1/4" - 12 NF	1115-1365	154-188
9/16" - 12 NC	100-120	14-17		1-3/8" - 6 NC	1315-1610	181-222
9/16" - 18 NF	110-130	15-18		1-3/8" - 12 NF	1510-1850	208-255
5/8" - 11 NC	135-165	19-23		1-1/2" - 6 NC	1745-2135	241-295
5/8" - 18 NF	160-200	22-28		1-1/2" - 12 NF	1880-2420	259-334

### Grade 8 Bolts, Nuts, Studs (Dry)

Thread Size	Torque			Thread Size	Torque	
	ft. lbs.	m-kg			ft. lbs.	m-kg
1/4" - 20 NC	10-15	1,4-2,1		3/4" - 10 NC	340-420	47-58
1/4" - 28 NF	15-20	2,1-2,8		3/4" - 16 NF	380-460	52-63
5/16" - 18 NC	20-30	2,8-4,1		7/8" - 9 NC	540-660	75-91
5/16" - 24 NF	25-30	3,5-4,1		7/8" - 14 NF	595-725	82-100
3/8" - 16 NC	40-50	5,5-6,9		1" - 8 NC	810-990	112-137
3/8" - 24 NF	45-55	6,2-7,6		1" - 12 NF	900-1100	124-152
7/16" - 14 NC	60-80	8,3-11,0		1-1/8" - 7 NC	1150-1400	159-193
7/16" - 20 NF	70-90	9,7-12,0		1-1/8" - 12 NF	1295-1585	179-219
1/2" - 13 NC	100-120	14-17		1-1/4" - 7 NC	1640-2000	226-276
1/2" - 20 NF	110-130	15-18		1-1/4" - 12 NF	1800-2200	248-304
9/16" - 12 NC	135-165	19-23		1-3/8" - 6 NC	2140-2620	295-362
9/16" - 18 NF	155-190	21-26		1-3/8" - 12 NF	2450-3000	338-414
5/8" - 11 NC	200-240	28-33		1-1/2" - 6 NC	2845-3475	393-480
5/8" - 18 NF	215-265	30-37		1-1/2" - 12 NF	3200-3900	442-538

### Hydraulic Fittings (Steel)

Dash Size	Tube O.D.	Thread Size	37° Flare Female Swivel Torque		Straight Thread O-Ring Torque	
			ft. lbs.	m-kg	ft. lbs.	m-kg
4	1/4	7/16 - 20	6-12	0,8-1,7	12-19	1,7-2,6
5	5/16	1/2 - 20	8-16	1,1-2,2	16-25	2,2-3,5
6	3/8	9/16 - 18	10-25	1,4-3,5	25-40	3,5-5,5
8	1/2	3/4 - 16	15-42	2,1-5,8	42-67	5,8-9,2
10	5/8	7/8 - 14	25-58	3,5-8,0	58-92	8,0-12,7
12	3/4	1-1/16 - 12	40-80	5,5-11,0	80-128	11-18
14	7/8	1-3/16 - 12	60-100	8,3-14,0	100-160	14-22
16	1	1-5/16 - 12	75-117	10-16	117-187	16-26
20	1-1/4	1-5/8 - 12	125-165	17-23	165-264	23-36
24	1-1/2	1-7/8 - 12	210-250	29-35	250-400	35-55

700926

# Section 1010

## GENERAL ENGINE SPECIFICATIONS W26 SERIES LOADER

### 504BDT DIESEL ENGINES

THE ENGINE MODEL AND SERIAL NUMBER IS STAMPED ON A PLATE LOCATED ON THE SIDE OF THE ENGINE ABOVE THE CRANKING MOTOR.

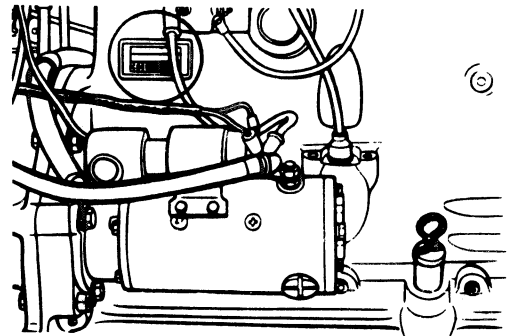

#### General

Type .....	6 Cylinder, 4 Stroke Cycle, Valve-in-Head Turbo-Charged
Firing Order .....	1-5-3-6-2-4
Bore .....	4-5/8 Inches (117.5mm)
Stroke .....	5 Inches (127mm)
Piston Displacement .....	504 Cubic Inches (8 259cm <sup>3</sup> )
Compression Ratio .....	15.8 to 1
No Load Governed Speed .....	2330-2370 RPM
Rated Engine Speed .....	2200 RPM
Engine Idling Speed .....	725 to 775 RPM
Exhaust Valve Rotators .....	Positive Type
*Valve Tappet Clearance (Exhaust) .....	(Hot) .020 Inch (0.508mm) (Cold) .025 Inch (0.635mm)
(Intake) .....	(Hot and Cold) .015 Inch (0.381mm)

\*Hot Settings Are Made After the Engine Has Operated At Thermostat Controlled Temperature For At Least Fifteen Minutes.

## **Piston and Connecting Rods**

Rings per Piston .....	3
Number of Compression Rings .....	2
Number of Oil Rings .....	1
Type Pins .....	Full Floating Type
Type Bearing .....	Replaceable Precision, Steel Back, Copper-Lead or Aluminum Alloy Liners

## **Main Bearings**

Number of Bearings .....	7
Type Bearings .....	Replaceable Precision Steel Back, Copper-Lead or Aluminum Alloy Liners

## **Engine Lubricating System**

Crankcase Capacity .....	12 U.S. Qts., 9.9 Imperial Qts. (11.4 liters)
with Filter Change .....	13 U.S. Qts., 10.8 Imperial Qts. (12.3 liters)
Oil Pressure .....	45 (310 kPa) to 60 (413 kPa) PSI with Engine Warm and Operating at Rated Engine Speed
Type System .....	Pressure and Spray Circulation
Oil Pump .....	Gear Type
Oil Filter .....	Full Flow Spin on Type

## **Fuel System**

Fuel Injection Pump .....	Robert Bosch, Type PES Multiple Plunger
Pump Timing .....	30 Degrees Before Top Dead Center (Port Closing)
Fuel Injectors .....	Pencil Type, Opening Pressure 3200 PSI (22 063 kPa)
Fuel Transfer Pump .....	Plunger Type, Integral Part of Injection Pump
Governor .....	Variable Speed, Fly-Weight Centrifugal Type, Integral Part of Injection Pump
1st Stage Fuel Filter .....	Full Flow Spin on Type
2nd Stage Fuel Filter .....	Full Flow Spin on Type

# Section 1020

## DETAILED SPECIFICATIONS 504BDT ENGINE

### FRACTION to DECIMAL to MILLIMETER CONVERSION TABLE

Fraction	Decimal	MM	Fraction	Decimal	MM	Fraction	Decimal	MM
1/64	.0156	0.397	23/64	.3593	9.128	45/64	.7031	17.859
1/32	.0312	0.794	3/8	.3750	9.525	23/32	.7187	18.256
3/64	.0468	1.191	25/64	.3906	9.922	47/64	.7343	18.653
1/16	.0625	1.587	13/32	.4062	10.319	3/4	.7500	19.050
5/64	.0781	1.984	27/64	.4218	10.716	49/64	.7656	19.447
3/32	.0937	2.381	7/16	.4375	11.113	25/32	.7812	19.844
7/64	.1093	2.778	29/64	.4531	11.509	51/64	.7968	20.240
1/8	.1250	3.175	15/32	.4687	11.906	13/16	.8125	20.637
9/64	.1406	3.572	31/64	.4843	12.303	53/64	.8281	21.034
5/32	.1562	3.969	1/2	.5000	12.700	27/32	.8437	21.431
11/64	.1718	4.366	33/64	.5156	13.097	55/64	.8593	21.828
3/16	.1875	4.762	17/32	.5312	13.494	7/8	.8750	22.225
13/64	.2031	5.159	35/64	.5468	13.890	57/64	.8906	22.622
7/32	.2187	5.556	9/16	.5625	14.287	29/32	.9062	23.019
15/64	.2343	5.953	37/64	.5781	14.684	59/64	.9218	23.415
1/4	.2500	6.350	19/32	.5937	15.081	15/16	.9375	23.812
17/64	.2656	6.747	39/64	.6093	15.478	61/64	.9531	24.209
9/32	.2812	7.144	5/8	.6250	15.875	31/32	.9687	24.606
19/64	.2968	7.541	41/64	.6406	16.272	63/64	.9843	25.003
5/16	.3125	7.937	21/32	.6562	16.669	1	1.0000	25.400
21/64	.3281	8.334	43/64	.6718	17.065			
11/32	.3437	8.731	11/16	.6875	17.462			

### INCH to MILLIMETER CONVERSION TABLE

Inch	MM	Inch	MM	Inch	MM	Inch	MM
1	25.400	6	152.000	10	254.000	60	1,524.000
2	50.800	7	177.800	20	508.000	70	1,778.000
3	76.200	8	203.200	30	762.000	80	2,032.000
4	101.600	9	228.600	40	1,016.000	90	2,286.000
5	127.000	10	254.000	50	1,270.000	100	2,540.000

## TABLE OF CONTENTS

RUN-IN INSTRUCTIONS .....	3,4
DETAILED ENGINE SPECIFICATIONS	
Cylinder Sleeves .....	5
Piston .....	5
Piston Rings .....	5
Oil Ring .....	5
Piston Pin .....	5
Connecting Rod .....	6
Crankshaft .....	6,7
Camshaft .....	7
Valve Push Rod Lifters .....	7
Gear Train .....	8
Oil Pump .....	8
Cylinder Head .....	8
Intake Valve .....	8,9
Exhaust Valve .....	9
Intake and Exhaust Valve Guides .....	9
Valve Spring .....	9
Rocker Arm Assembly .....	10
SPECIAL TORQUES .....	10
GENERAL TORQUE SPECIFICATION TABLE .....	11

## RUN-IN INSTRUCTIONS

### Engine Lubrication

When the engine rebuild is complete, fill the engine crankcase with Case HDM oil and install new engine oil filters. **NOTE:** If Case HDM oil is not used, use only a Series 3 DS or CD Service Classification oil that has the proper viscosity rating for prevailing air temperature. Refer to vehicle Operators Manual.

After the first 20 hours of operation, change the engine oil while the engine is hot and replace the engine oil filter/s. **DO NOT DRAIN OIL UNTIL THE ENGINE HAS BEEN OPERATED 20 HOURS.**

Change the engine oil and filter/s at the recommended intervals thereafter as outlined in the Operator's Manual.

### Break-In Procedure for Rebuilt Engines (With a Dynamometer)

The following procedure must be implemented when using a PTO dynamometer to break-in the engine. The dynamometer will insure control of the engine load at each speed and will eliminate over stressing new parts during break-in.

During the break-in, continually check the oil pressure, coolant level, and coolant temperature.

STEP	TIME	ENGINE SPEED	DYNAMOMETER SCALE LOAD*
1	**10 Minutes	1000 RPM	None
2	**10 Minutes	1800 RPM	None
3	20 Minutes	1800 RPM	1/3
4	20 Minutes	1800 RPM	1/2
5	***30 Minutes	100 RPM below rated speed	3/4
6	Retorque the cylinder head bolts using the procedure described in Section 2015 of this service manual.		

\*Based upon normal dynamometer scale load at rated speed for the particular vehicle model. Reduce this scale load as indicated.

\*\*The most ideal break-in procedure would be to constantly vary the throttle between 750 to 1000 RPM for the first 10 minutes and from 1000 RPM to 1800 RPM for the next 10 minutes. The purpose of this changing RPM is to vary the lubrication and coolant flow.

\*\*\*30 minutes at 3/4 load is a minimum amount of time the engine should be run. It is recommended that whenever possible the engine (especially turbocharged diesels) should be run for four (4) hours or more at the above speed and load before checking the full engine horsepower or before using the engine for heavy field work.

### Break-In Procedure for Rebuilt Engines (Without a Dynamometer)

STEP	TIME	ENGINE SPEED	LOAD
1	*10 Minutes	1000 RPM	None
2	*10 Minutes	1800 RPM	None
3	30 Minutes	2/3 Rated RPM	Light Load
4	1 Hour	Full RPM (not over 2000 RPM)	80 to 90%
5	Retorque the cylinder head bolts using the procedure described in Section 2015 of this service manual.		

\*If engine must then run at or near full load to operate the machine - for first hour remove load and run at high idle for a few minutes at 15 minute intervals.

## **Run-In Procedure (Agricultural Tractors)**

For the first 8 hours of field operation stay one gear lower than normal. For the next 12 hours DO NOT "lug" the engine. Prevent "lugging" by shifting to a lower gear. The engine must not be "lugged" below its Rated Engine RPM during the early hours of life.

## **Run-In Procedure (Construction Equipment)**

For the first 8 hours, operate the engine at full throttle maintaining a normal load. DO NOT baby the engine, but avoid prolonged converter or hydraulic stall. Engine must not be "lugged" below its Rated Engine RPM (Do not exceed 10 seconds of stall).

## **Run-In Procedure (Power Units)**

For the first 1/2 hour, operate engine at 2/3 rated RPM with a light load or no load. For the next (1) hour, run engine at 80 to 90% load at rated RPM (but not over 2000 RPM). Then full load and rated RPM as required in application.

## DETAILED ENGINE SPECIFICATONS

### Cylinder Sleeves

	Decimal System	Metric System
I.D. of sleeve including wear .....	4.6250 to 4.6333"	117.475 to 117.7163mm
Sleeve out of round (installed in block) .....	.001"	.025mm
Maximum Limit including wear .....	.002"	.0508mm
Taper (installed in block) .....	.001"	.0254mm
Maximum limit including wear .....	.007"	.1778mm
Clearance to bottom of piston skirt, 90° to piston pin including wear .....	.0052 to .0175"	.1321 to .445mm

### Piston

Type .....	Cam ground	
Material .....	Aluminum Alloy	
O.D. at bottom of skirt, 90° to piston pin including wear .....	4.6178 to 4.6198"	117.2921 to 117.3429mm
I.D. of piston pin bore including wear .....	1.8001 to 1.8015"	45.7225 to 45.7581mm
Width of 3rd ring groove including wear .....	.188 to .191"	4.775 to 4.851mm

### Piston Rings

No. 1 Compression (chrome) .....	Keystone	
End gap in 4.625 I.D. (117.475 I.D.) sleeve including wear .....	.017 to .037"	.432 to .940mm
No. 2 Compression (chrome) .....	Keystone	
End gap in 4.625 I.D. (117.475mm I.D.) sleeve including wear .....	.013 to .033"	.330 to .838mm

### Oil Ring

Width .....	.186 to .187"	4.724 to 4.75mm
End gap in 4.625 I.D. (117.475mm I.D.) sleeve .....	.013 to .033"	.330 to .838mm
Side clearance including wear .....	.001 to .005"	.025 to .127mm

### Piston Pin

Type .....	Full Floating	
O.D. of pin .....	1.7994 to 1.7996"	45.7052 to 45.7102mm
Fit in piston .....	.0005 to .0011"	.0127 to .0279mm
Fit in rod bushing .....	.0008 to .0014"	.0203 to .0356mm

**Connecting Rod**

Decimal System

Metric System

Bushing .....	Replaceable	
Bushing I.D. installed (ream to size) .....	1.8004 to 1.8008"	45.7302 to 45.7403mm
Maximum limit including wear .....	1.8018"	45.7657mm
Bushing out of round including wear .....	.0015"	.0377mm
Bearing liners .....	Replaceable	
Bearing liner width .....	1.586 to 1.596"	40.284 to 40.538mm
Journal I.D. without bearing liners .....	3.1503 to 3.1513"	80.0176 to 80.0426mm
Bearing oil clearance including wear .....	.0013 to .005"	.0326 to .127mm
Undersize bearings for service .....	.002,.010,.020,.030"	.051,.254,.508,.762mm
Side clearance .....	.007 to .016"	.178 to .406mm
Cap bolts .....	12 point flange head	

**Crankshaft**

Type .....	Balanced	
Main bearing liners .....	Replaceable	
End play, No. 5 main bearing cap including wear .....	.003 to .020"	.076 to .508mm
Thrust bearings std. thickness including wear .....	.147 to .157"	3.734 to 3.988mm
Thrust bearings oversize thickness for service including wear .....	.153 to .163"	3.886 to 4.140mm
Connecting rod journal std. O.D. ....	2.998 to 2.999"	76.149 to 76.175mm
.010" (.254mm) O.D. undersize, grind to .....	2.988 to 2.989"	75.895 to 75.921mm
.020" (.508mm) O.D. undersize, grind to .....	2.978 to 2.979"	75.641 to 75.667mm
.030" (.762mm) O.D. undersize, grind to .....	2.968 to 2.969"	75.387 to 75.413mm
Connecting rod journal maximum taper including wear .....	.0015"	.0377mm
Journals out of round .....	.0005"	.0127mm
Main bearing liner width 1st, 3rd, 5th and 7th .....	2.1515 to 2.1615"	54.6477 to 54.9017mm
Main bearing liner width 2nd, 4th and 6th .....	1.214 to 1.224"	30.836 to 31.09mm
Undersize main bearing liners for service .....	.002,.010,.020,.030"	.051,.254,.508,.762mm
Main bearing oil clearance including wear .....	.0016 to .006"	.0402 to .152mm
Main bearing journal std. O.D. ....	3.498 to 3.499"	88.849 to 88.875mm
.010" (.254mm) O.D. undersize, grind to .....	3.488 to 3.489"	88.595 to 88.621mm
.020" (.508mm) O.D. undersize, grind to .....	3.478 to 3.479"	88.341 to 88.367mm
.030" (.762mm) O.D. undersize, grind to .....	3.468 to 3.469"	88.087 to 88.113mm
Main journal bore I.D. without liners .....	3.691 to 3.692"	93.751 to 93.777mm

**Crankshaft (Cont'd)**

	Decimal System	Metric System
Main journal width between cheeks:		
2nd, 4th and 6th .....	1.618 to 1.633"	41.097 to 41.478mm
3rd .....	2.555 to 2.570"	64.897 to 65.278mm
5th .....	2.561 to 2.565"	65.049 to 65.151mm
7th .....	2.585 to 2.600"	65.659 to 66.040mm
Connecting rod journals width between cheeks .....	1.9775 to 2.0025"	50.2287 to 50.8637mm

**Camshaft**

Type .....	Parabolic	
Bushings .....	5, Replaceable	
Bushing Lubrication .....	Pressurized	
Oil clearance including wear .....	.0014 to .0124"	.0352 to .3150mm
I.D. of bushing including wear .....	2.2484 to 2.2554"	57.1092 to 57.2872mm
Bushing width:		
1st (front) .....	1.646 to 1.666"	41.808 to 42.316mm
2nd, 3rd and 4th .....	1.4275 to 1.4475"	36.2587 to 36.7667mm
5th .....	1.1462 to 1.1662"	29.1131 to 29.6211mm
O.D. of each bearing surface including wear .....	2.242 to 2.247"	56.947 to 57.074mm
Thrust washer thickness including wear .....	.1105 to .1275"	2.8067 to 3.2385mm
Thrust plunger spring:		
Free length .....	3.625"	92.075mm
O.D. of spring .....	.3912 to .4062"	9.9361 to 10.3171mm
Compressed 2.750" (69.85mm) .....	45 to 55 lbs.	20.37 kg. to 24.97 kg.

**Valve Push Rod Lifters**

Type .....	Mushroom	
O.D. of lifter stem, standard .....	.8097 to .8102"	20.5668 to 20.5791mm
O.D. of lifter stem, oversize for service .....	.8190 to .8195"	20.803 to 20.8157mm
I.D. of block bore, std. including wear .....	.8115 to .8145"	20.6117 to 20.6883mm
I.D. of block bore, oversize for service .....	.8215 to .8225"	20.8657 to 20.8917mm

**Gear Train**

Decimal System

Metric System

## Backlash:

Crankshaft gear to camshaft gear .....	.004 to .011"	.102 to .279mm
Idler drive gear to idler gear .....	.003 to .010"	.076 to .254mm
Idler gear to fuel pump gear .....	.004 to .012"	.102 to .305mm
Crankshaft gear to oil pump gear .....	.006 to .011"	.152 to .279mm
Crankshaft gear to fuel pump gear .....	Maximum .027"	Maximum .686mm
O.D. of idler gear shaft including wear .....	1.732 to 1.733"	43.993 to 44.019mm
I.D. of idler gear with bushing including wear .....	1.7345 to 1.740"	44.0567 to 44.196mm
Idler gear thrust washer thickness .....	.057 to .063"	1.448 to 1.600mm
Idler gear end play (maximum limit including wear) .....	.010"	.254mm

**Oil Pump**

Positive displacement .....	Gear Type	
Backlash, pump gear to crankshaft gear .....	.006 to .011"	.152 to .279mm
Drive gear to pump body clearance .....	.0035 to .0065"	.0889 to .1651mm
Pump gears to body radial clearance including wear .	.003 to .009"	.0760 to .229mm
Pump gears to pump cover clearance including wear	.0015 to .008"	.0377 to .203mm
Oil pressure .....	45 to 60 PSI	3.164 to 4.218 kg/cm <sup>2</sup>
Relief valve spring:		
No. coils .....	12	
Wire thickness .....	.071"	1.803mm
Minimum I.D. ....	.469"	11.913mm
Free length .....	2.06"	52.32mm
Compressed 1.252" (31.801mm) .....	17.25 to 19 lbs.	7.84 to 8.62 kg

**Cylinder Head**

Warpage .....	(Max. Limit Incl. wear) .005"	0.127mm
---------------	-------------------------------	---------

**Intake Valve**

Tappet clearance (COLD and HOT) .....	.015"	3.81mm
Face angle .....	44 <sup>0</sup>	44 <sup>0</sup>
Face run-out (max. limit Incl. wear) .....	.002"	.051mm
Length .....	6.4195 to 6.4405"	163.0557 to 163.5887mm
O.D. of stem including wear .....	.400 to .403"	10.160 to 10.236mm
O.D. of head .....	1.995 to 2.005"	50.673 to 50.927mm
Seat angle .....	45 <sup>0</sup>	45 <sup>0</sup>



**Suggest:**

**If the above button click is invalid.**

**Please download this document**

**first, and then click the above link**

**to download the complete manual.**

**Thank you so much for reading**

**Intake Valve (Cont'd)**

	Decimal System	Metric System
Seat contact width .....	.0775 to .0975"	1.9685 to 2.4511mm
Seat run-out (max. limit Incl. wear) .....	.002"	.051mm
Insert height .....	.2775 to .2825"	7.0485 to 7.1755
O.D. of insert .....	2.0990 to 2.1000"	53.315 to 53.34mm
I.D. of insert .....	1.805 to 1.815"	45.847 to 46.101mm

**Exhaust Valve**

Tappet clearance (COLD) .....	.025"	.635mm
Tappet clearance (HOT) .....	.020"	.508mm
Face angle .....	44°	44°
Fan run-out .....	(Max. Limit Incl. wear) .002"	.051mm
O.D. of head .....	1.745 to 1.755"	44.323 to 44.577mm
O.D. of stem end including wear .....	.400 to .403"	10.160 to 10.236mm
O.D. of taper 4.2675" (108.3947mm) including wear .....	.399 to .402"	10.135 to 10.211mm
Length .....	6.4195 to 6.4405"	163.0557 to 163.5887mm
Insert seat angle .....	45°	45°
Seat contact width .....	.0800 to .1000"	2.032 to 2.540mm
Seat run-out (max. limit Incl. wear) .....	.002"	.051mm
Insert height .....	.313 to .316"	7.95 to 8.026mm
O.D. of insert .....	1.9455 to 1.9465"	49.4157 to 49.4407mm
I.D. of insert .....	1.571 to 1.577"	39.903 to 40.056mm

**Intake and Exhaust Valve Guides**

Length .....	3.219"	81.763mm
O.D. ....	.7510 to .7515"	19.075 to 19.202mm
I.D. (installed and reamed) .....	.4045 to .4055"	10.2747 to 10.2997mm
Maximum limit including wear .....	.4065"	10.3251mm
Protrusion above cylinder head .....	.953"	24.206mm

**Valve Spring**

Free length .....	2.28"	57.912mm
Total coils .....	7.75	
Wire diameter .....	.171"	4.343mm
Compressed to 1.48" (30.480mm) (valve open) .....	135 to 145 lbs.	61.24 to 65.78 kg.
Compressed to 1.94" (49.276mm) (valve closed) .....	40 to 50 lbs.	18.14 to 22.68 kg.

**<https://www.ebooklibonline.com>**

Hello dear friend!

Thank you very much for reading.

Enter the link into your browser.

The full manual is available for immediate download.

**<https://www.ebooklibonline.com>**