

W9, W9A, W10, AND W12 LOADERS TABLE OF CONTENTS

SERIES/SECTION	SECTION NO.	FORM NO.
10	SERIES - GENERAL	
	Specifications for W9 and W9A Engines	C 9-74563
	Specifications for W10 and W12 Engines	CC 9-74562
20	SERIES - ENGINE	
	Cylinder Heads, Valve Systems, Rocker Arms, Decompressor on Diesel Engines	K 9-76972
	Cylinder Heads, Valve Systems, Rocker Arms on Spark Ignition Engines	L 9-76962
	Assemblies Contained in Engine Block	M 9-75222
	Engine Counter Balancer	MM 9-76731
	Water Pump	3M 9-76741
	Spark Ignition Governor	4M 9-76751
	Governor Linkage	None 9-75711
30	SERIES - FUEL SYSTEM	
	Fuel Injectors, Fuel Injection Pump	I 9-75421
	TSX Series Gasoline Carburetor	N 9-75771
40	SERIES - HYDRAULICS	
	Relief Valve Pressure Setting	None 9-74562
	Hydraulic Cylinders	A 9-76621
	"H" Series Gear Type Hydraulic Pump	B 9-74562
	VDP-4 and VY-5 Hydraulic Control Valves	D 9-74562
	Relief Valve and Lift Spool on VY-5 Hydraulic Control Valve	D, Supp't 1 9-74562
	VDP-14 Hydraulic Control Valve	DD 9-74561
	Model 32 Backhoe	3D 9-75091
50	SERIES - STEERING	
	Combined Unit Power Steering Valve and Gear Box, Steering Linkage, Power Steering Cylinder (W9 and W9A)	O 9-74561
	Gear and Roll Type Power Steering Pumps	P 9-74561
	Combined Unit Power Steering Cylinder and Valve, Steering Linkage, Steering Gear Box (W10 and W12)	Q 9-74563
60	SERIES - POWER TRAIN	
	Model CRT 3331-1 Allison Torqmatic Transmission . . .	None SA1073
	Single Reduction Differentials, Universal Joints, Drive Shafts	T 9-74561
	Planetaries and Axles	U 9-74561

SERIES/SECTION

SECTION NO.

FORM NO.

70 SERIES - BRAKES

Series "01" Hydraulic Brake Cylinder, Brake Shoes and Drums (W9, W9A)	W	9-74562
Power Assist Hydraulic Brake Valve, Brake Shoes and Drums (W10 and W12)	WW	9-74562
Hydrovac Brake System	3W	9-74563

80 SERIES - ELECTRICAL

Wiring Diagrams		
W9 Gasoline Electrical Systems	None	9-76701
W9A Gasoline Electrical Systems	None	9-76711
W10, W12 Diesel Electrical Systems	None	9-76691
Electrical System, Cranking Circuit, Charging Circuit (24-volt Alternator)		
	F	9-75202
Electrical System	3F	9-76721

SECTION

K

SERVICING THE



CYLINDER HEADS



VALVE SYSTEMS



ROCKER ARMS



DECOMPRESSOR

ON

CASE POWRCEL DIESEL ENGINES

<https://www.ebooklibonline.com>

Hello dear friend!

Thank you very much for reading.

Enter the link into your browser.

The full manual is available for immediate download.

<https://www.ebooklibonline.com>

TABLE OF CONTENTS

CYLINDER HEAD AND COMPONENTS - Disassembly and Installation	K-2 thru K-5
DECOMPRESSOR (If So Equipped) - Disassembly and Assembly	K-6
ROCKER ARMS AND SHAFTS - Disassembly, Inspection and Assembly	K-8
CYLINDER HEAD AND VALVES - Disassembly and Assembly	K-10
EXHAUST VALVE ROTATORS	K-10
VALVES, GUIDES AND SPRINGS - Inspection	K-12
INTAKE AND EXHAUST VALVES - Refacing	K-14
INTAKE AND EXHAUST VALVE SEATS - Grinding	K-15
LOCATING TOP DEAD CENTER AND TAPPET ADJUSTMENT	K-16

CYLINDER HEAD AND COMPONENTS

(Refer to Figure K-1)

Removal

Steam clean the engine completely before doing any disassembly or service work.

Drain cooling system. Remove the intake, exhaust and water manifolds. Remove the rocker arm covers. Disconnect and remove the decompressor if so equipped, Page K-6.

Remove the rocker arm assemblies and tag them for proper installation. (Refer to Page K-8.

Disconnect the high pressure fuel lines to

the injectors and cap them. Disconnect the fuel leak-off tubes between each cylinder head and cap them.

Remove the push rods and tag or store them in a holder or rack so they can be installed in their same locations.

Remove the cylinder head bolts or nuts and lift the heads off the engine. Remove the head gaskets and discard them.

Inspection and Installation

Remove all carbon and clean all parts before installation.

STANDARD HEAD GASKETS

If you are installing the standard gasket, install the new gasket with new rubber seals. The gasket must be installed with either the copper side up or the side with the case part number up. Continued on Page K-5.

FIRE RING HEAD GASKETS

If you are installing the fire ring head gasket, inset B, cylinder sleeve protrusion

must be checked to determine which fire ring to install. Only the standard fire ring is included in the valve grind gasket kit, however a thicker fire ring (.004") is available if the protrusion checks indicate a need for it. The thicker fire ring can be identified by a blue marking stripe.

Refer to Pages K-4 and K-5 for the procedure to follow when installing the fire ring cylinder head gasket.

REMOVAL AND INSTALLATION OF CYLINDER HEAD AND COMPONENTS

CAUTION
DO NOT OVER
TIGHTEN COVER NUTS

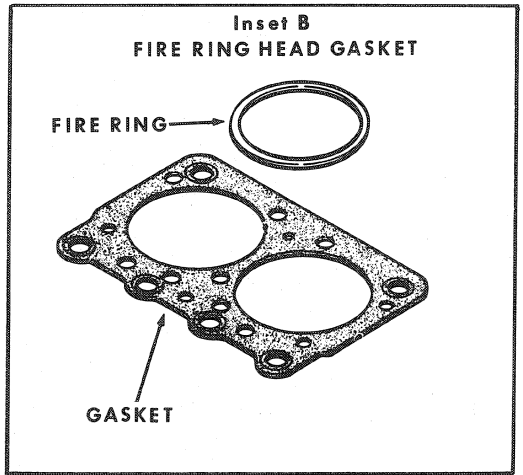
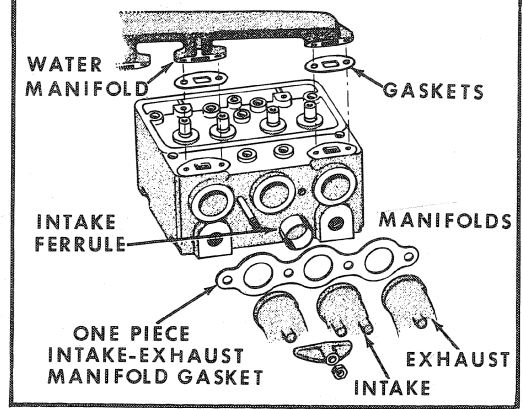
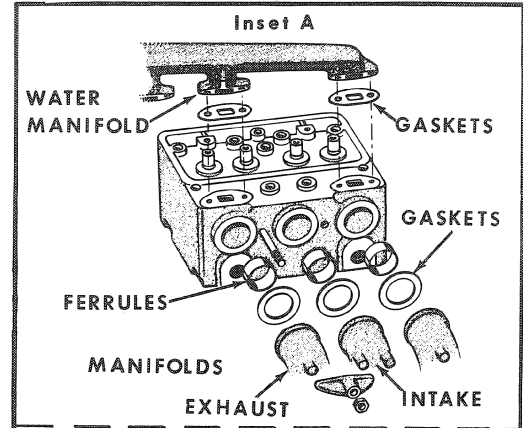
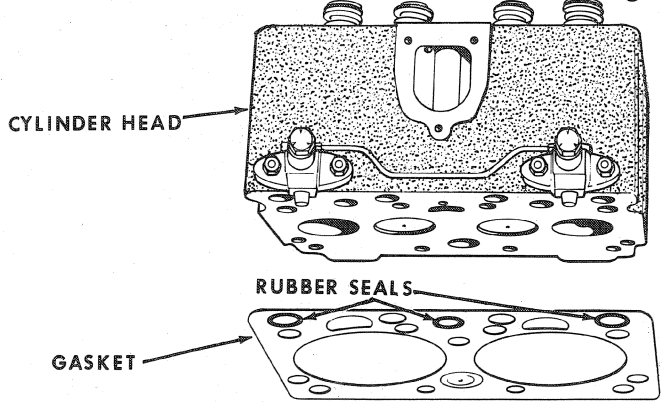
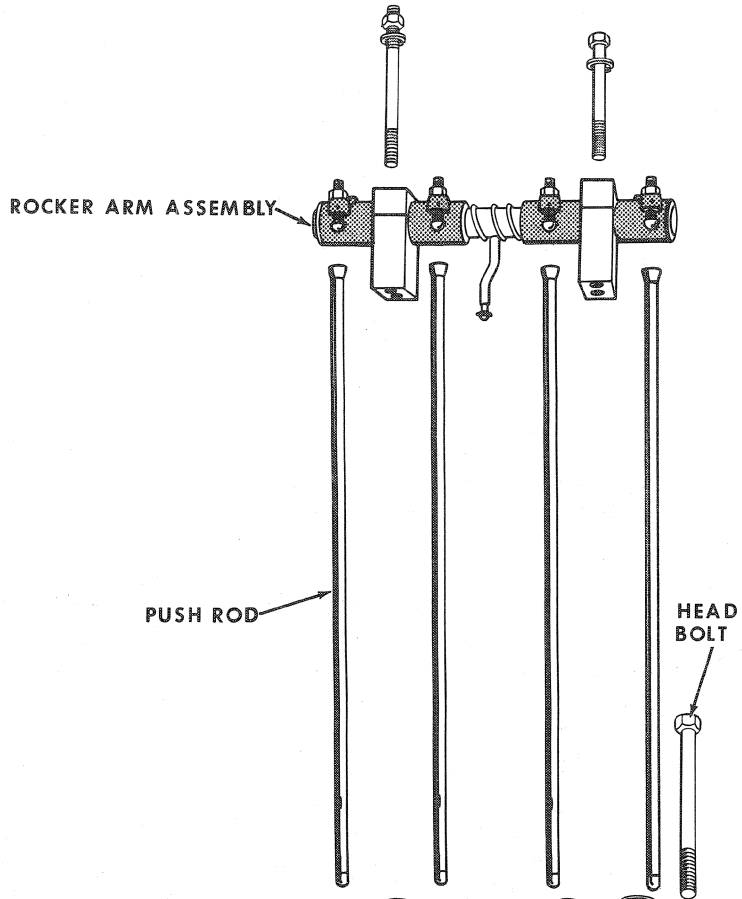
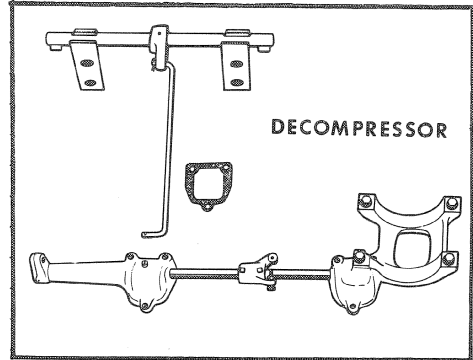
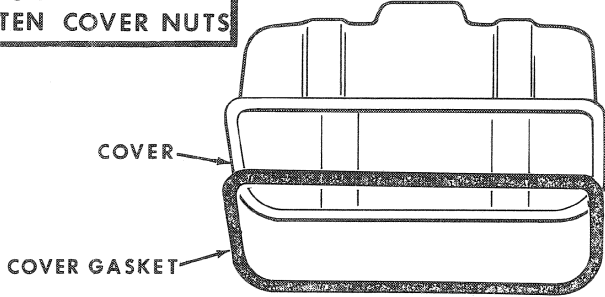

Inspection and Installation Fire Ring Gaskets (Continued)

The following procedure must be followed when installing the fire ring head gasket:

1. Clean the top surface of the block and sleeve flange carefully. All traces of carbon and other deposits must be removed. During the final cleaning operation, the use of a rag dampened in solvent is recommended.
2. Using a small stone, remove any small burrs in the areas to be measured so that accurate readings can be obtained.

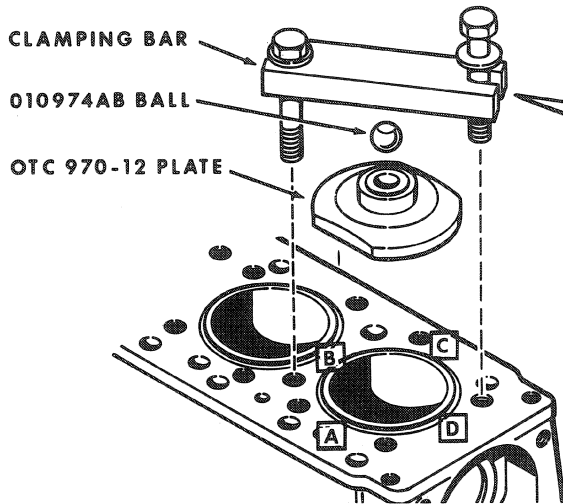

MEASURE SLEEVE PROTRUSION AT POINTS A, B, C, AND D.

Figure K-2

4. Either a magnetic base dial indicator or a depth micrometer can now be used to determine the cylinder sleeve protrusion as indicated in Figure K-3. Refer to chart, Figure K-5, to make sure the correct fire ring is used.

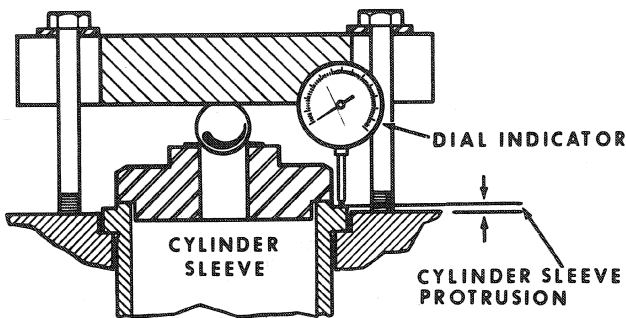
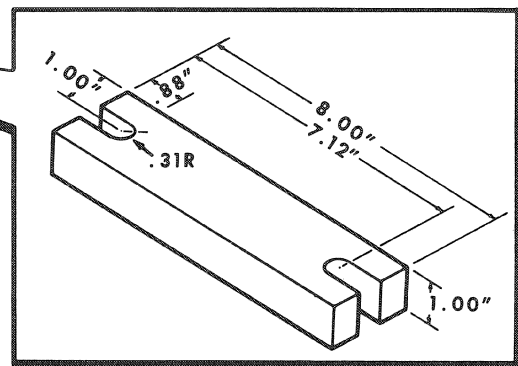

Figure K-3

5. Install cylinder head gaskets. **IMPORTANT** Two of the capscrew holes in the gasket are slightly smaller and act as guides to position the gasket as well as the fire ring,

3. Using plate OTC970-12* from cylinder sleeve puller OTC970*, 010974AB ball and clamping bar, clamp the cylinder sleeve in place, Figure K-2. Torque the hold down capscrews evenly to 50 foot pounds. **NOTE** Refer to Figure K-2 for clamping bar dimensions.

*These tools are available through local Owatonna Tool Dealers or the Owatonna Tool Co., Owatonna, Minnesota.



- Figure K-4. Regular line-up studs could be used for most engines. In some instances it is very difficult to install the

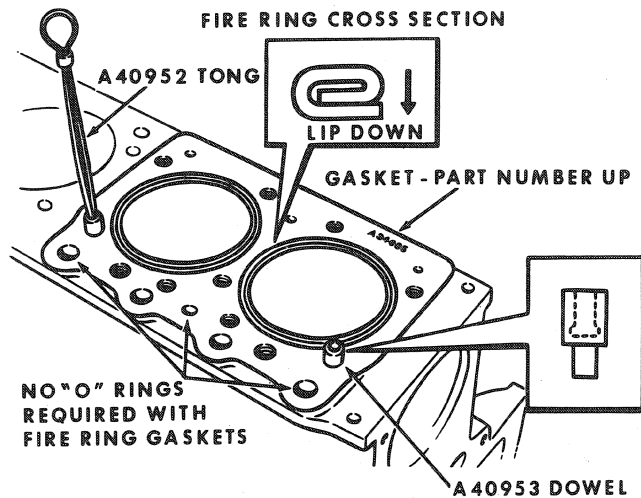

Figure K-4

rear cylinder head due to the limited space in which to place the head when lowering it down over the long guide studs.

Inspection and Installation(Continued)

CYLINDER SLEEVE PROTRUSION	USE STANDARD FIRE RING	USE OVERSIZE (THICKNESS) FIRE RING
BOTH SLEEVES UNDER ONE HEAD FLUSH TO .002"		X
BOTH SLEEVES UNDER ONE HEAD .002" OR OVER BUT LESS THAN .0025" BETWEEN SLEEVES	X	
BOTH SLEEVES UNDER ONE HEAD OVER .0025" DIFFERENCE BETWEEN SLEEVES	ON THE HIGH SLEEVE	ON THE LOW SLEEVE

Figure K-5

6. For difficult installations, the use of dowel pins and a tong are recommended and can be purchased through a local Snap-On Tool Dealer or J.I. Case Central Parts Dept. under the following part numbers.

Snap-On Tool No.	Case Part No.
CF83-1 Tong	A40952
CF83-4 Dowel	A40953

7. Install the fire rings with the lip downwards, Figure K-4. **NOTE** Fire ring gaskets must be installed dry.

8. Carefully clean the cylinder heads as described in No. 1. If evidence of fretting or erosion exist in the area of the fire ring contact or if the head is warped more than .005", the head must be resurfaced.

9. Install cylinder heads and several bolts, then remove the A40953 dowels using A40952 tong and install all the bolts.

STANDARD AND FIRE RING HEAD GASKETS

10. Install intake and exhaust manifold ferrules and new gaskets. **NOTE** When the manifolds are designed for the one piece manifold gasket, the ferrules are used only in the intake ports. Refer to Page K-3, inset A. Install the intake and exhaust manifolds and torque to proper torque. Refer to Specification Section.

11. Torque cylinder head bolts or nuts to the proper sequence illustrated in Figure K-6. The three torquing steps recommended are 50 foot pounds, 100 foot pounds and finally 150 foot pounds.

12. Install the push rods in their original location. Connect the high pressure fuel lines and leak-off tubes. Install the de-

compressor (if so equipped.) Refer to Page K-16 for proper firing order.

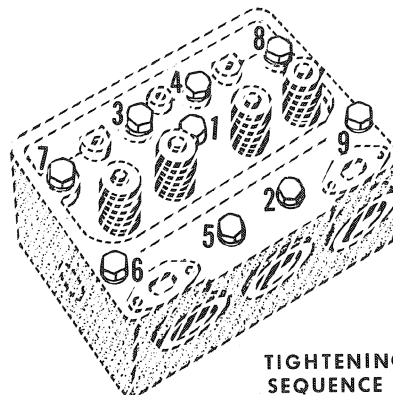

Figure K-6

13. Install the rocker arm assemblies in their original location.

14. Adjust the valve tappet clearance, refer to Page K-16.

15. Fill cooling system and start engine. Check that the rocker arms are receiving lubrication.

16. Run engine for approximately one (1) hour, under load if possible, to thoroughly warm up the engine and seat the head gaskets.

17. Stop the engine and retorque the cylinder head bolts or nuts to 150 foot pounds while the engine is still hot. Check and readjust the tappets.

18. Clean the rocker arm covers and remove the old gasket. Install new gaskets and seals; then install covers. Refer to Specification Section for proper torque. Do not over torque the valve cover nuts.

INSPECTION OF DECOMPRESSOR

(If So Equipped)

(Refer to Figure K-7)

When the decompressor is engaged all the exhaust valves must be held in an open position. Inspect the trip pins for excessive wear. Inspect for bent or worn control linkage if the valves are not held open.

When the decompressor is disengaged and the tappet clearance is correct be sure the trip pins release the rocker arms completely. Inspect for loose coupling set screws, bent or worn control linkage, control link cotter pin missing or a pin in one of the control levers sheared off.

DISASSEMBLY OF DECOMPRESSOR

(Refer to Figure K-7)

Remove the control link cotter pins (1) and link (2). Remove the decompressor control housings (3) and the housing gaskets (4). Loosen the coupling set screws (5) and remove the coupling (6).

Remove the roll pins (7) from the control

levers (8). Remove the control shafts (9) from the housings. Remove the control levers (8). Remove the trip pins (10) from the decompressor shaft (11). Remove and discard the "O" rings (12) from the shafts.

ASSEMBLY

(Refer to Figure K-7)

Install the trip pins (10) and lever (8) with roll pin (7) to the decompressor mounting brackets (13). Install the new "O" rings (12) on the shafts - Install the shafts (9) into the housings (3) and install the control levers (8) with roll pins (7). Install the shaft coupl-

ing (6) and tighten square head set screws (5).

Install the housing and shaft assembly to the cylinder heads with new gaskets (4). Install the control link (2) with cotter pins (1).

DECOMPRESSOR ADJUSTMENTS

(Refer to Figure K-7)

The stop bolts (14) in the coupling stop (6) should be adjusted so the decompressor can open the valves when engaged and lift the trip pins so they are clear of the rocker arms when disengaged (Refer to Inset A). Tighten the lock nuts (15) on the stop bolts (14) after adjustment is made.

DISASSEMBLY AND ASSEMBLY OF DECOMPRESSOR

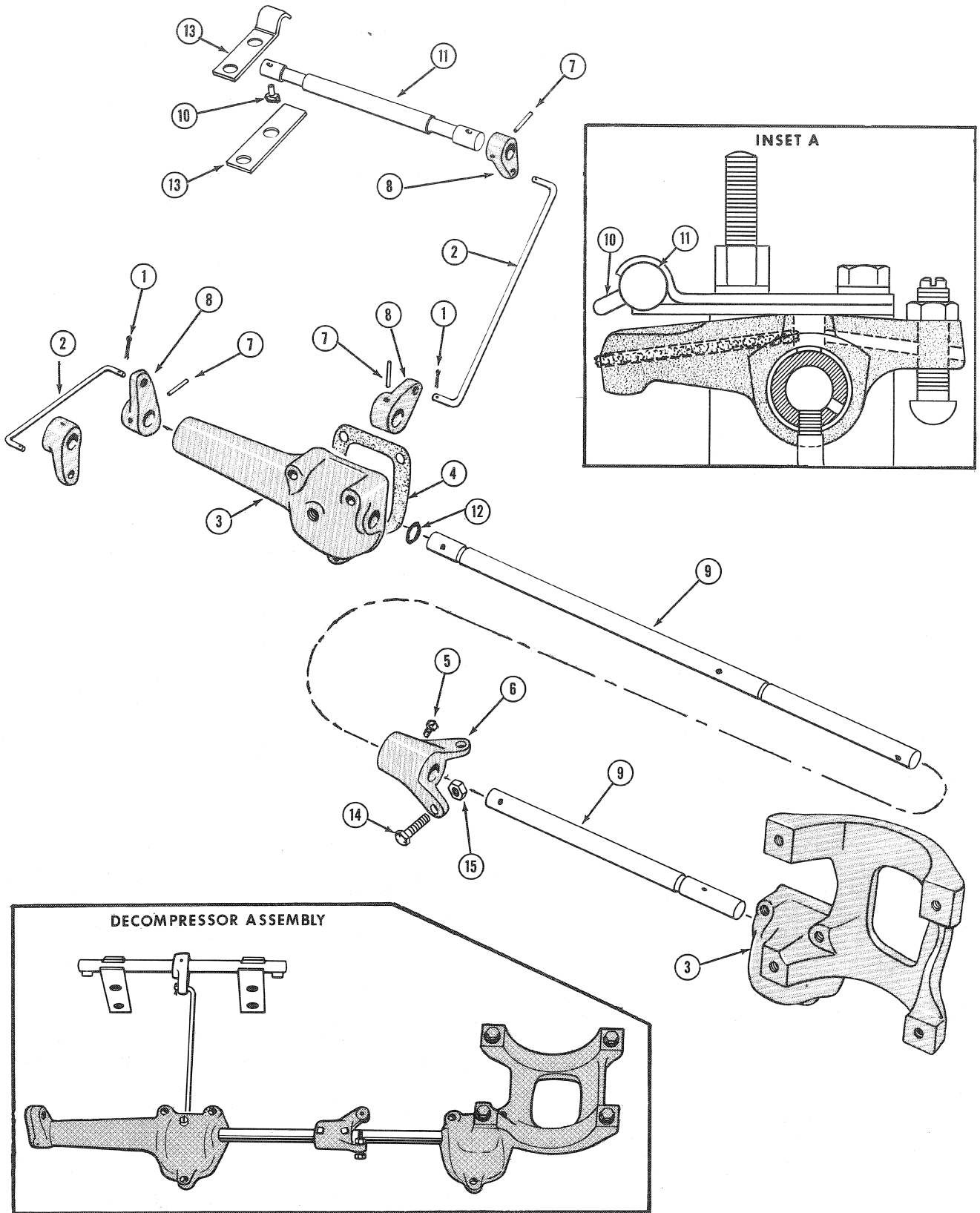

Figure K-7

DISASSEMBLY OF THE ROCKER ARMS (Refer to Figure K-8)

Remove the rocker arm shaft bracket studs (15) and bolts (16). Remove and tag shaft assemblies for installation.

Unscrew the oil tube (1) and discard the "O" ring (2). Remove the snap rings (3), spacer washer (5) and keep count of the number of washers at each end of the shaft. Tag each rocker arm for original location. Remove the exhaust rocker arms (6) and the shaft brackets (7) from each end of the shaft.

Remove the intake rocker arms (8) and the shaft spring (9). Remove the plugs (10) by

using a rod and driving one plug clear thru the shaft. This will also clean out the dirt or sludge that has formed inside of the shaft.

Replacement shafts have these plugs installed at the factory. Remove the push rods and store them in a rack or holder so they can be installed in their original location.

Remove the oil wick (11) from each exhaust rocker arm and discard. Remove the bushing (12) from the cast rocker arm if it is worn using an Arbor (See Inset A).

INSPECTION (Refer to Figure K-8)

Inspect the shaft spring for proper tension and broken coils. Refer to "Specification" Section. Inspect the rocker arm shaft for excessive worn spots on the bottom side of the shaft. Replace shaft if worn condition exists.

Inspect the rocker arm bushings by installing each rocker arm on the shaft in its proper location. The rocker arm must be free on the shaft without any side "wobble" If any is noted replace the cast rocker arm

bushing or replace the stamped rocker arm. Note the stamped rocker arm bushing is not replaceable. Replacement rocker arms come complete with bushings. Inspect the valve contact area on the rocker arm for wear. Replace if worn. Inspect the tappet adjusting screw for wear marks or pitting. Inspect the push rods for straightness, cracked or worn ends.

ASSEMBLY (Refer to Figure K-8)

Clean all parts thoroughly. Place new bushing on Arbor and press into the cast rocker arm so the bushing (12) is evenly centered in the rocker arm and the oil hole is lined up with the oil hole in the rocker arm, (See Inset A). Check the bushing for high or rough spots and if they exist, they should be honed out. Install new oil wick (11) in the exhaust rocker arm. Lubricate each part with engine oil as they are installed.

Install a shaft spring (9) and two intake rocker arms (8) on the shaft (4). When installing the cast rocker arms the adjusting screw and the shaft oil hole must be on the same side, (See Inset A).

When installing the stamped steel rocker arms the adjusting screw and the shaft oil hole must be on opposite sides (See inset B).

Install the shaft brackets (7) on the shaft with the split side toward the push rod side of the engine. Install the exhaust rocker arms

(6) on the shaft. Install the same number of spacer washers (5) that were removed.

Install the snap rings (3) at each end of the shaft. Check the rocker arms for free movement. Install the oil tube (1) with new "O" ring (2). Install the push rods in their original location if they were removed. Install the adjusting screws (13) and lock nuts (14) if they were removed.

Install the rocker arm and shaft assembly on the cylinder head. Make sure all the push rods are engaged with the adjusting screws. Install the bracket studs (15) and bolts (16). Refer to "Specification" Section for proper torque. Check that the oil tube is in the oil hole in the cylinder head. Check exhaust rocker arms for excessive end play. One or more spacer washers can be used between the rocker arm and snap ring to remove the excessive end play. Check and adjust the tappet clearance. (Refer to Page K-16.)

DISASSEMBLY AND ASSEMBLY OF THE ROCKER ARMS

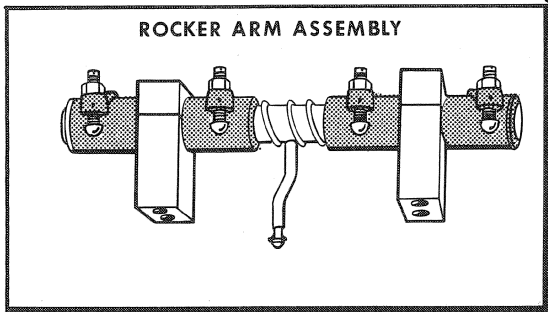
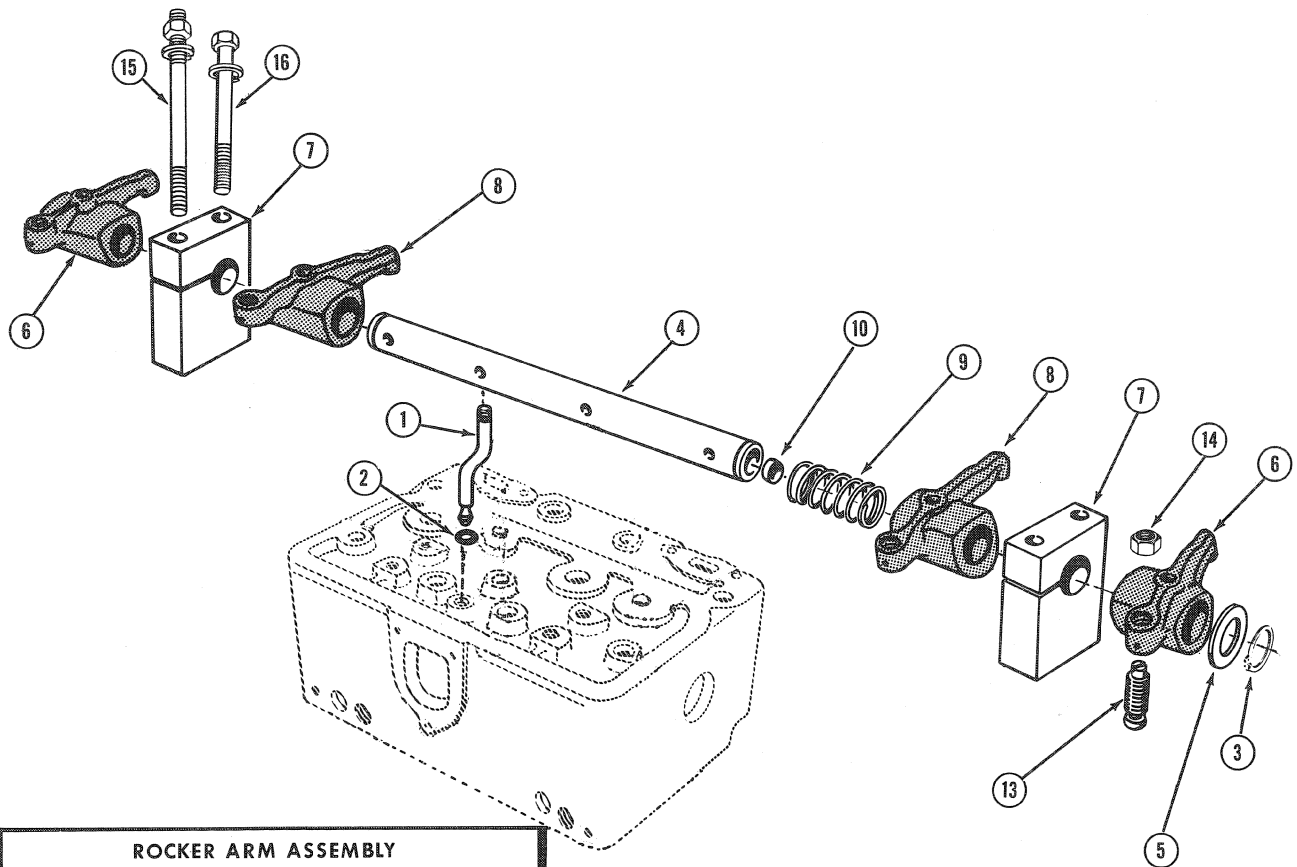
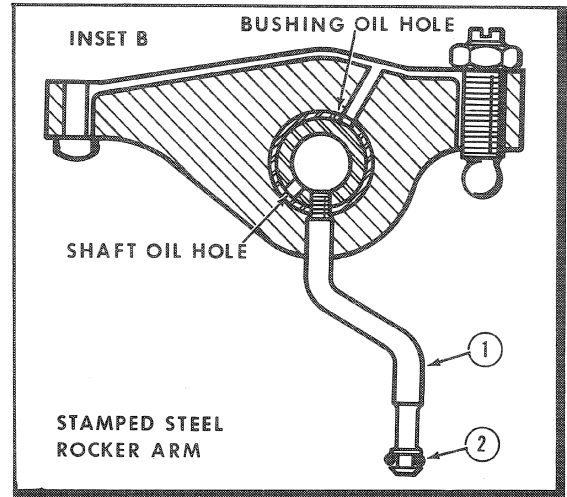
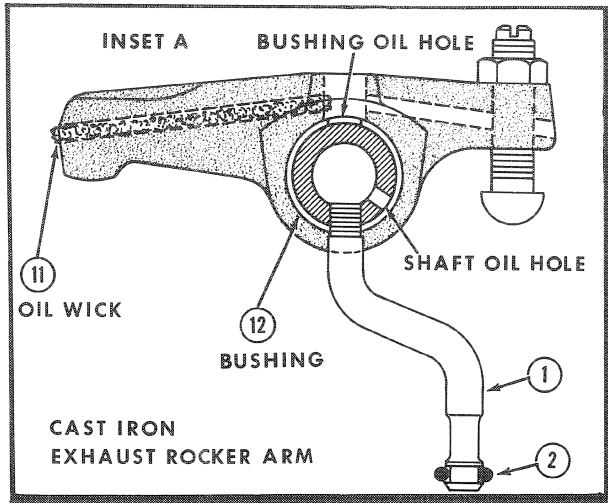

Figure K-8

DISASSEMBLY OF THE CYLINDER HEAD AND VALVES (Refer to Figure K-9)

Using a valve spring compressor (Refer to Inset A) compress the spring (1). Remove the valve retainer locks (2) and the spring retainers (3) or valve rotators (4). Remove the valve springs (1), valve stem oil seal (5) and the valve spring seat. Remove any carbon from the valve stems before they are moved from the head.

Remove the intake valves (7) and the exhaust valves (8) from the head and store them in a rack or holder. Remove the intake valve guide (9) exhaust valve guide (10)

down through head using an Arbor (See Inset B). Refer to "Specification" Section for dimension of valve guides. The exhaust valve seats (11) can be removed with a special seat removing tool (See Inset C).

NOTE Never attempt to remove a valve seat with a center punch, cold chisel or pry bar.

To remove the expansion plug (12) it must be drilled and then pryed out.

ASSEMBLY (Refer to Figure K-9)

Clean head completely and check for cracks. Remove all carbon from the bore of the valve guides with a wire brush and blow out with compressed air.

Install new valve guides (9 and 10) using an Arbor (See Inset B) and press the guides into the head from the top of the head. The distance the guides must protrude above the head is given in the "Specification" Section.

To install new exhaust valve seats (11) clean the recess in the cylinder head. Place the valve seats in dry ice to shrink them for easy installation. Insert the valve seats in the head and drive them in place using suitable driver. Lubricate the valves (7 and 8)

with engine oil and install them in the original location.

Install the valve spring seats (6), valve springs (1) and intake valve stem oil seal (5). Install the exhaust valve rotators (4) and the intake valve spring retainers (3). Compress the valve springs so the valve retainer locks (2) can be installed.

Install new expansion plug (12). Refer to Page K-2 for reinstalling the cylinder head.

EXHAUST VALVE ROTATOR (Refer to Figure K-9)

When re-installing the rocker arm assembly, check the operation of the exhaust valve rotators. To check the operation of the rotators, place a dab of white paint on the rotator - note its position; -- then start the engine and observe whether or not the rotator is turning. Replace any rotators that will not turn. Do not attempt repairs on rotators.

It is impossible to determine whether or not the rotator is turning without an identifying mark.

There is no set speed at which the rotators should turn; some rotators will turn faster than others. As long as the rotator is turning the valve, it is functioning properly.

NOTE

An excessive accumulation of deposits on the exhaust valve face and stem is also an indication that the rotators may not be functioning properly.

IMPORTANT

When installing valve rotators:

Reassemble the rotator with original valve as they tend to become matched parts when they wear in.

If it is necessary to install a new valve always install a new rotator and retaining lock.

DISASSEMBLY AND ASSEMBLY OF THE CYLINDER HEAD AND VALVES

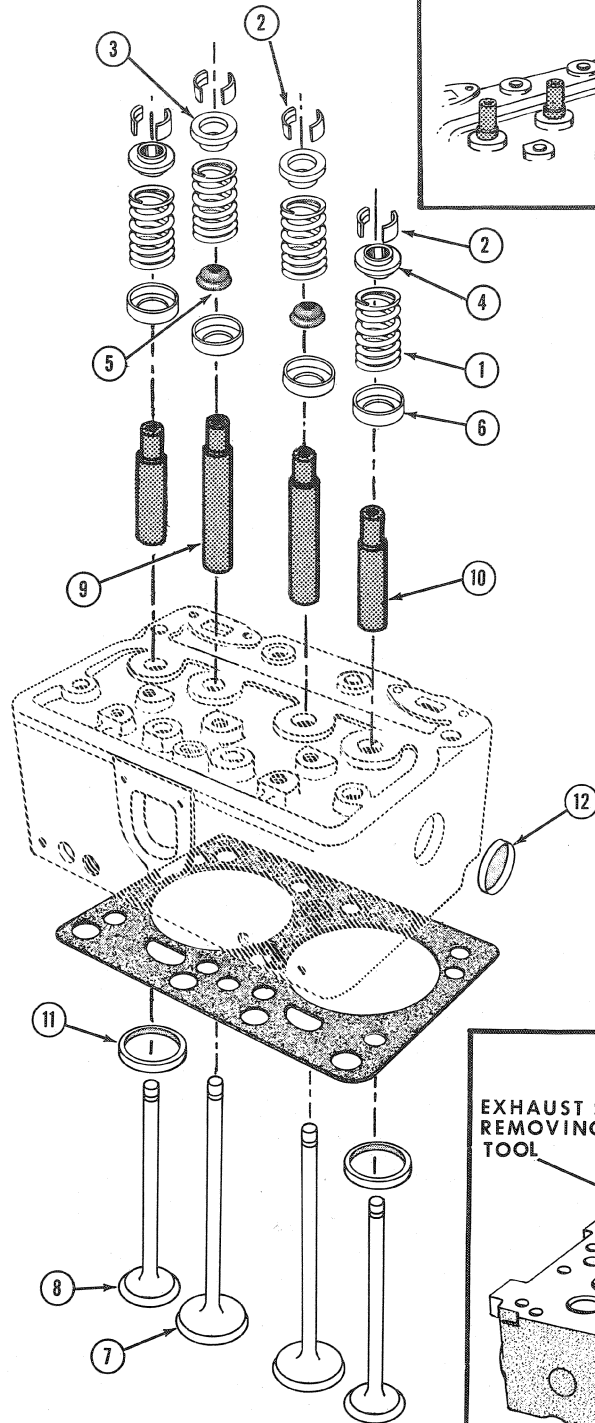
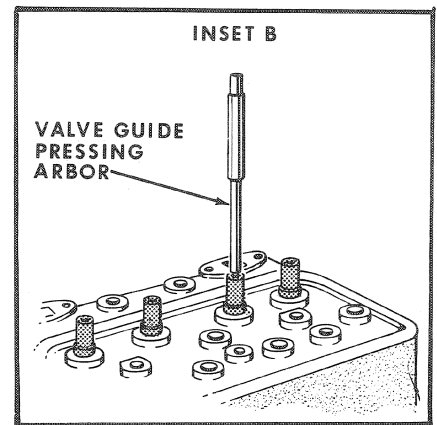
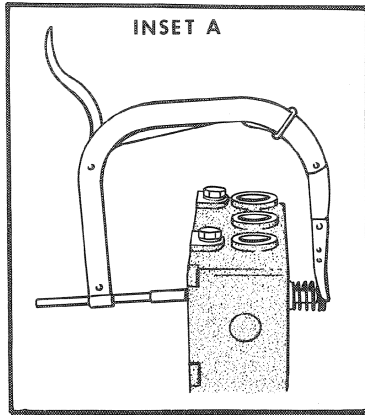
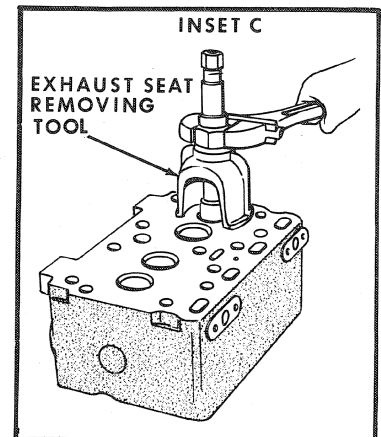
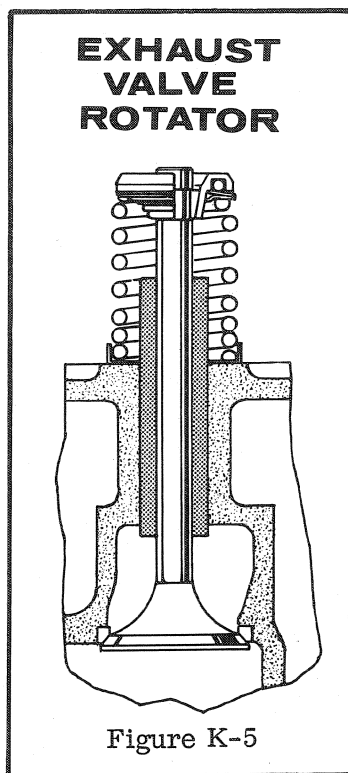

Figure K-9



INSPECTION OF THE VALVES, GUIDES AND SPRINGS

Valve springs should be checked for flat squared ends, broken or cracked coils and correct spring pressure. Use a Valve Spring Tension Tester. Refer to the "Specification" Section.

Valve guides can be checked for wear by using a bore gauge and micrometer (Refer to Figure K-11.) The valve guide should be checked at the top, middle and bottom of the bore for wear. Refer to Figure 10. The inside diameter wear limits of the valve guide should not exceed the specification given in the "Specification" Section, at any point along the bore of the guide. Replace guide if it does. Check the new valve guides after installation to make sure that the bore is not less than the inside diameter given in the "Specification" Section. Using an Arbor equal to the inside diameter of the valve guide will keep the guide from collapsing when pressed in place.

Clean the valves with a power driven fine wire brush, being very careful not to scratch the valve stems. Reference is made to the different parts of the valve (Refer to Figure K-12.)

Inspect the valves for excessive wear or necked stems (Refer to Figure K-13). This can be caused by lack of lubrication, plugged or dirty water passages or operating the engine under continuous overload at excessive engine RPM. Valves should be replaced.

Inspect the valves for deep grooves in the face (Refer to Figure K-14.) This can be caused by abrasives entering the engine through the intake system or not servicing the air cleaner regularly. A leaking valve cover gasket can also cause this condition. If grinding the valve face will not correct this condition, discard the valves.

Inspect the valve face and stem for rust or pitting (Refer to Figure K-15). Rust or pitting can usually be removed by grinding the valve face. If rust or pitting on the valve stem exist the valve should be replaced. These conditions can be caused by using poor quality engine oil or fuel that doesn't meet the specification given in the Operator's Manual. Rust could be caused by improper storing of the engine.

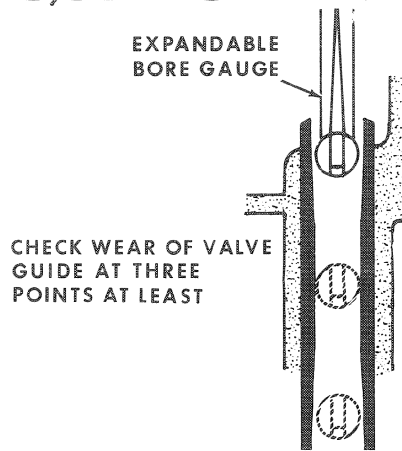

Figure K-10

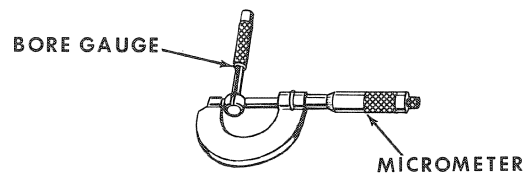

Figure K-11

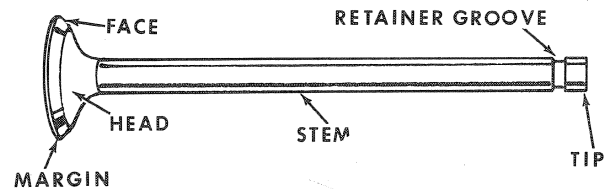

Figure K-12

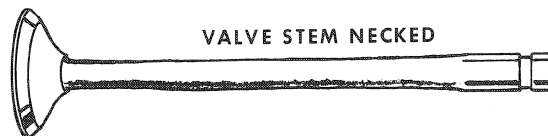

Figure K-13

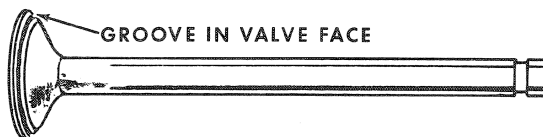

Figure K-14

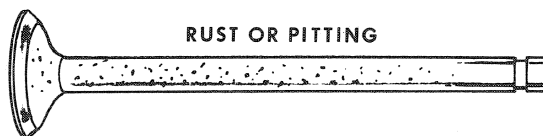

Figure K-15

INSPECTION OF THE VALVES, GUIDES AND SPRINGS (Contd)

Heavy carbon or varnish deposits on the valve (Refer to Figure K-16) should be removed before valves are ground. This condition is usually caused by worn piston rings and sleeves which allow too much oil to reach the combustion chamber. This condition could also be caused by worn valve guides or no seals on the intake valves. Low operating temperature is still another cause. These conditions should be corrected or the same trouble with the valves will happen again.

Inspect the valve head for dishing and the valve face for deep burned spots, Figure K-17. These conditions can't be corrected by grinding the valves. The valves should be replaced. These conditions are usually caused by running the engine under excessive load at high engine temperatures.

Valves with worn keeper grooves or the stem is worn or dished beyond the chamfer must be replaced (Refer to Figure K-18).

The checking of the valve stem diameter can best be done with a good accurate micrometer (Refer to Figure K-19). The valve stem should not vary more than the wear limits given in the "Specification" Section at any point on the valve stem. If this condition exists the valves must be replaced.

The checking of the valve face runout should be done after the valves have been ground. A Vee block type holder with a dial indicator (Refer to Figure K-20) should be used to check the valve face runout. The valve face should not vary more than the specification given in the "Specification" Section. The valve stem runout can also be checked with this Vee block and dial indicator.

IMPORTANT

Small amounts of very fine pitting, Figure K-21, may be found on the surfaces of the valve faces and seats after the valves are cleaned. These are normal and will not affect engine performance. This fine pitting is caused by a normal oxidation process and can happen on any engine during the run-in period. It is not necessary to grind valves or seats if this fine pitting is found as the pitting will generally reoccur after the engine is run for a few hours.

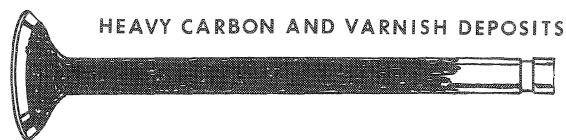

Figure K-16

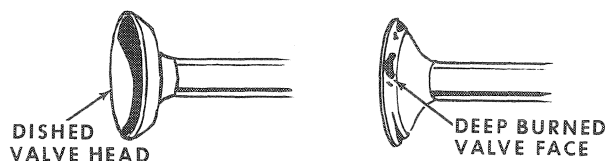

Figure K-17

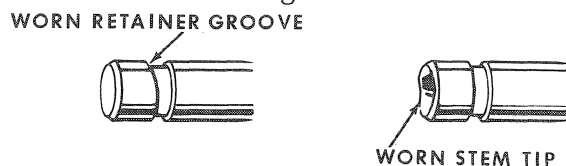

Figure K-18

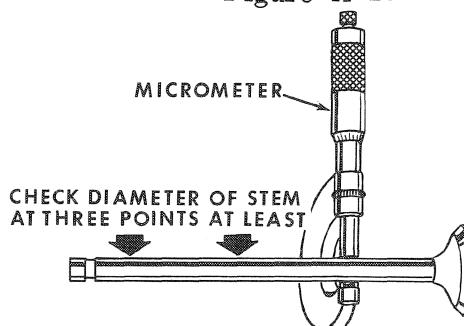

Figure K-19

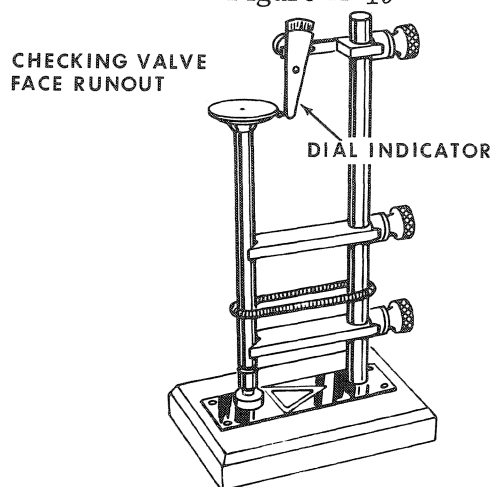

Figure K-20



Figure K-21

REFACING INTAKE AND EXHAUST VALVES

Before refacing the valves they should be wire brushed, cleaned and inspected. Refer to the "Specification" Section for the correct valve face grinding angle. Set the refacing machine protractor at this angle. Be sure the chuck of the machine is clean before installing valve. Dress the grinding wheel before starting to reface each valve. Take only light cuts as the valve is refaced and the last cut must be very fine so the valve face will have a polished finish.

IMPORTANT Replace any valve that after grinding has a thin edge or margin (Refer to Figure K-22). If the margin on the ground valve is less than half the margin on a new valve replace the valve.

The tip end of the valve should be checked for roughness or wear. Usually this can be removed with some very light cuts against the side of the grinding wheel and will square up the end. Never grind the chamfer off the valve stem end. Any excessive grinding should not be done to the stem end. Replace the valve.

Before installing new valves a fine finish grinding should be done to each new valve. Check the valve face and valve stem runout before installing (Refer to Page 13).

The valve face and seat contact location should be checked. Place valve bluing (Prussian Blue) on the face of the valve. Install the valve in the head and rotate the valve on its seat. Remove the valve and inspect the contact area on the valve face. The bluing will have been removed from the valve face evenly at the top edge of the contact area (Refer to Figure K-23). This is due to the fact that the valve face and seat are ground with 1° INTERFERENCE ANGLE. Refer to "Specification" Section.

When the top edge of the contact area is too high or low on the valve face, the seat contact area must be moved. This is done by using the narrowing stones (Refer to Page K-15). The contact area width should never exceed the dimension given in the "Specification" Section.

CAUTION DO NOT USE BLUING TO CHECK VALVE SEAT AND VALVE FACE RUN-OUT.

The valve face could be contacting the seat at only a few points, but the bluing would still be rubbed off by the high points and make it appear as though you had solid contact all around. The only thing bluing will indicate is the location on the valve face where the seat is contacting -- no more!

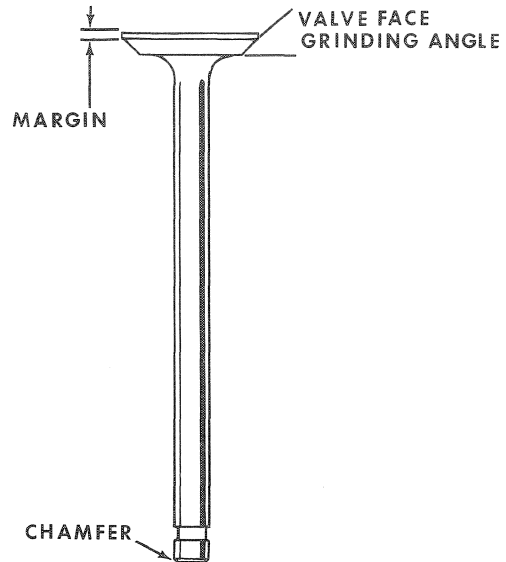

Figure K-22

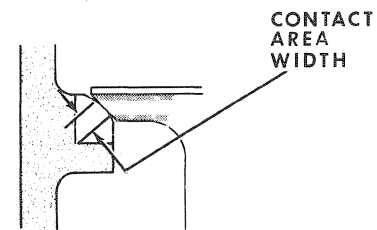
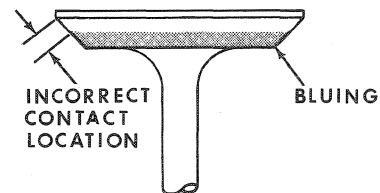
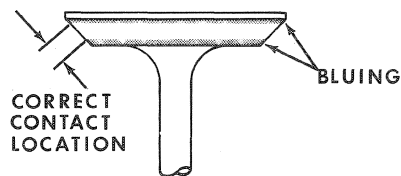

Figure K-23

GRINDING INTAKE AND EXHAUST VALVE SEATS

Always use a precision type power seat grinder similar to the one shown in Figure K-24. The valve seats can not be ground with manual operated equipment. The intake valve seat is part of the head and for this reason only a finishing stone should be used to grind the seat. The exhaust valve seat should be first ground with a roughing stone and then use a finishing stone. Take very light cuts with the grinding stones so just enough metal is removed to end up with a good smooth seat finish.

Refer to the "Specification" Section for the proper specifications of the intake, exhaust seats and valve guides (Refer to Figure K-25). From the specifications the proper grinding stones and pilot can be chosen.

When using the grinding stones the seat grinding angle of the stone should be dressed on a (stone dresser) frequently so the seat angle will not vary when grinding the seats.

INSPECTION

The valve seat runout should be checked after finish grinding with a dial indicator and seat grinding pilot (Refer to Figure K-26). After checking the runout, turn the pilot 1/4 turn and check runout again. The width of the valve seat contact area must also be checked. Refer to "Specification" Section for dimension of seat width contact area.

The valve seat contact area width should never vary from this dimension. The exhaust valve seat contact area width and location can be changed by using the 30° and 60° narrowing stone. Refer to Figure K-27.

CAUTION The intake valve seat should not be changed by using the narrowing stones. If the seat width exceeds the dimension given in the "Specification" Section, the cylinder head should be replaced.

When the step above the intake seat (Refer to Figure K-25) has been reduced by the grinding operation, installing a new valve will help to restore the compression that would normally be lost by excessive grinding of the seat and valves. Excessive grinding of the valves and seats moves the valves further into the head thereby reducing the compression ratio.

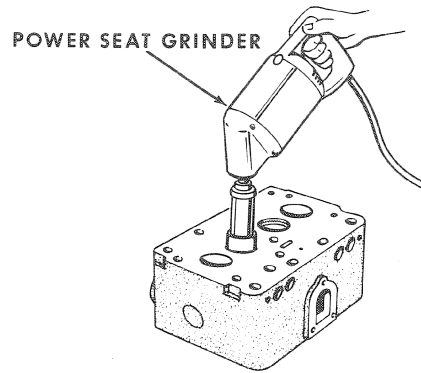

Figure K-24

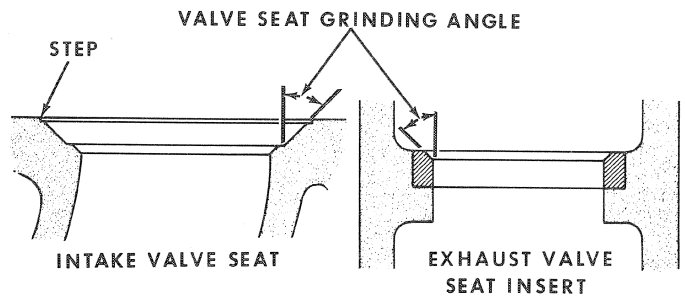

Figure K-25

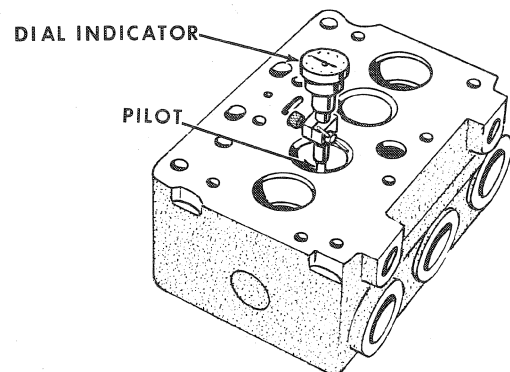

Figure K-26

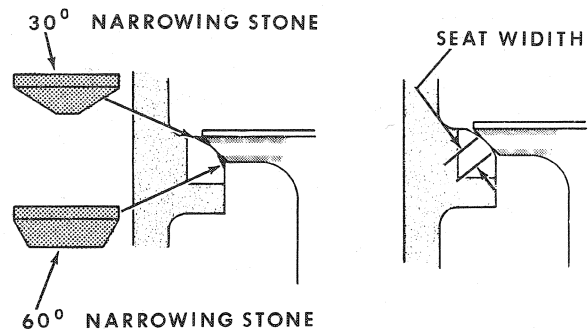

Figure K-27

LOCATING TOP DEAD CENTER AND TAPPET ADJUSTMENT

Refer to "Specification Section" for the correct tappet clearance.

The two valve tappets for each cylinder are to be checked and adjusted when the piston for that particular cylinder is at top dead center on the compression stroke. Start with the number 1 cylinder (nearest the radiator) and follow the sequence of firing order.

4 Cylinder

Firing Order ----- 1-3-4-2

The top dead center position of the pistons for checking valve clearance is indicated by marks on the crankshaft pulley flange. The 4 cylinder engines use the marks 180° apart, Figure K-28.

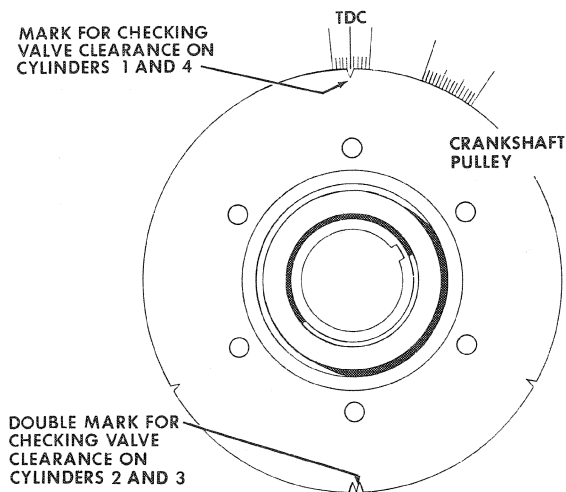

Figure K-28

NUMBER 1 CYLINDER

To set No. 1 cylinder on top of compression stroke remove the valve covers and crank engine until the push rods are loose on No. 1 cylinder (top of compression stroke) and the rocker arms on the opposing cylinder No. 4 can be rocked open or closed with a slight back and forth movement of the crankshaft. Then check and adjust the valve tappets on No. 1 cylinder, refer to Figure K- 29.

NUMBER 3 CYLINDER

Crank the engine approximately 1/2 turn or until the push rods on No. 3 cylinder are loose and the rocker arms on the opposing

cylinder No. 2 can be rocked open or closed slightly by crank movement. Adjust tappets on No. 3 Cylinder.

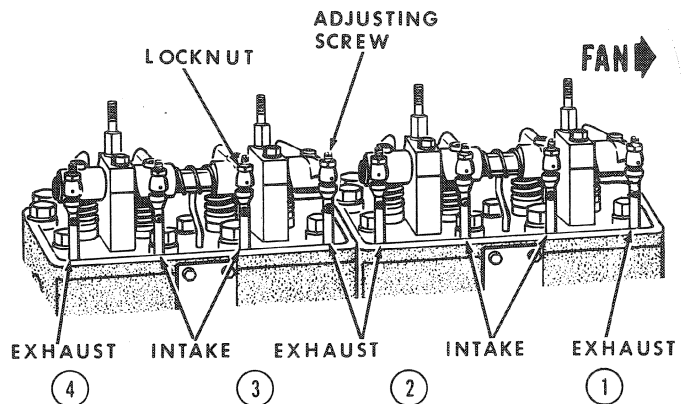

Figure K-29

NUMBER 4 CYLINDER

Crank engine another 1/2 revolution or until the push rods on No. 4 cylinder are loose and the rocker arms on No. 1 can be rocked open or closed slightly by crank movement. Adjust tappets on No. 4 cylinder.

NUMBER 2 CYLINDER

Crank engine another 1/2 revolution or until the push rods on No. 2 cylinder are loose and the rocker arms on No. 3 can be rocked open or closed slightly by crank movement. Adjust tappets on No. 2 cylinder.

While the valve covers are removed, start the engine and check that the rocker arm assemblies are receiving proper lubrication; then install new valve cover gaskets and replace valve covers properly to prevent oil leaks.

LOCATING TOP DEAD-CENTER AND TAPPET ADJUSTMENT

6 Cylinder

Firing Order ----- 1-5-3-6-2-4

The top dead center position of Nos. 1 and 6 cylinders is indicated by the TDC mark on the crankshaft pulley flange.

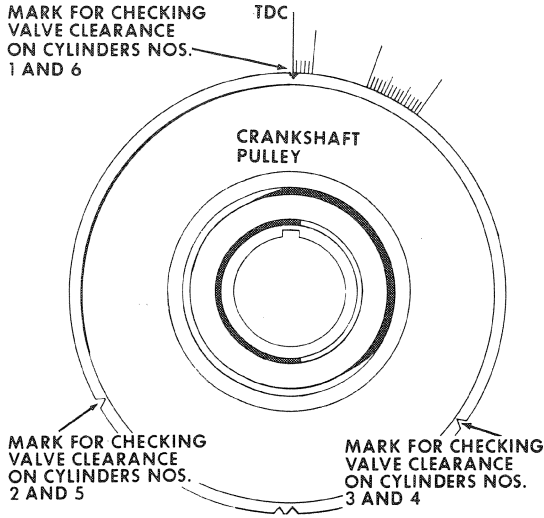

Figure K-30

NUMBER 1 CYLINDER

To set No. 1 cylinder on top of compression stroke, remove the valve covers and crank engine until the push rods are loose on No. 1 cylinder (top of compression stroke) and the rocker arms on the opposing cylinder No. 6 can be rocked open or closed with a slight movement of the crankshaft. Then crank and adjust the valve tappets on No. 1 cylinder, refer to Figure K-31.

NUMBER 5 CYLINDER

Crank the engine approximately 1/3 turn or until the push rods on No. 5 are loose and the rocker arms on No. 2 can be rocked open or closed slightly by crank movement. Adjust tappets on No. 5 cylinder.

NUMBER 3 CYLINDER

Crank engine another 1/3 revolution or until the push rods on No. 3 cylinder are loose and the rocker arms on No. 4 can be rocked open or closed slightly by crank movement. Adjust tappets on No. 3 cylinder.

NUMBER 6 CYLINDER

Crank engine another 1/3 (TDC mark) revolution or until the push rods on No. 6 are loose and the rocker arms on No. 1 can be rocked open or closed slightly by crank movement. Adjust tappets on No. 6 cylinder.

NUMBER 2 CYLINDER

Crank engine another 1/3 revolution or until the push rods on No. 2 cylinder are loose and the rocker arms on No. 5 can be rocked open or closed slightly by crank movement. Adjust the tappets on No. 2 cylinder.

NUMBER 4 CYLINDER

Crank engine another 1/3 revolution or until the push rods on No. 4 cylinder are loose and the rocker arms on No 3 can be rocked open or closed slightly by crank movement. Adjust the tappets on No. 4 cylinder.

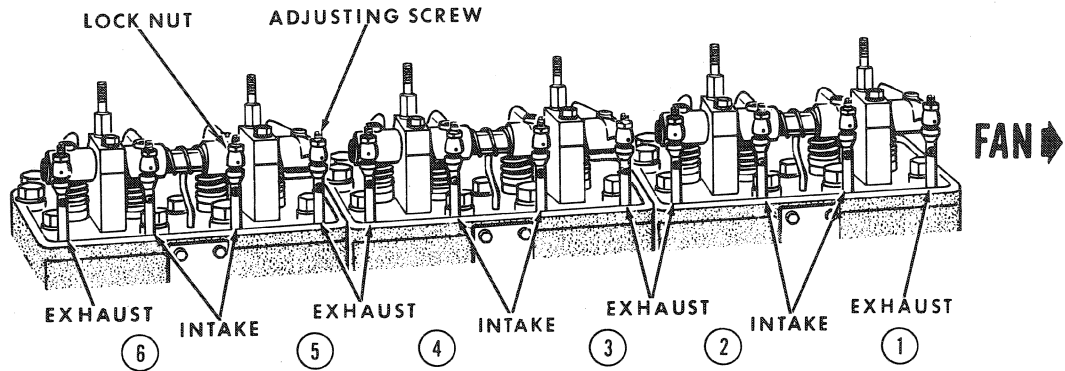

Figure K-31

SECTION

L

SERVICING THE



CYLINDER HEADS



VALVE SYSTEMS



ROCKER ARMS

ON

CASE POWRDYNE SPARK IGNITION ENGINES

TABLE OF CONTENTS

CYLINDER HEAD AND COMPONENTS - Disassembly and Installation. L-2 thru L-5	
ROCKER ARMS AND SHAFTS - Disassembly, Inspection and Assembly	L-6
CYLINDER HEAD AND VALVES - Disassembly and Assembly	L-8
EXHAUST VALVE ROTATORS	L-8
VALVES, GUIDES AND SPRINGS - Inspection	L-10
INTAKE AND EXHAUST VALVES - Refacing.	L-12
INTAKE AND EXHAUST VALVE SEATS - Grinding	L-13
LOCATING TOP DEAD CENTER AND TAPPET ADJUSTMENT	L-14

CYLINDER HEAD AND COMPONENTS

(Refer to Figure L-1)

Removal

Steam clean the engine completely before doing any disassembly or service work.

Drain cooling system. Disconnect the fuel line, throttle and choke control at the carburetor. Remove the spark plug wires from each spark plug. Remove the intake, exhaust and water manifolds. Remove the rocker arm covers.

Remove the rocker arm assemblies and

tag them for proper installation. (Refer to Page L-6).

Remove the push rods and tag or store them in a holder or rack so they can be installed in their same locations.

Remove the cylinder head bolts or nuts and lift the heads off the engine. Remove the head gaskets and discard them.

Inspection and Installation

Remove all carbon and clean all parts before installation.

STANDARD HEAD GASKETS

If you are installing the standard gasket, install the new gasket with new rubber seals. The gasket must be installed with either the copper side up or the side with the case part number up. Continued on Page L-5.

FIRE RING HEAD GASKETS

If you are installing the fire ring head gasket, inset B, cylinder sleeve protrusion

must be checked to determine which fire ring to install. Only the standard fire ring is included in the valve grind gasket kit, however a thicker fire ring (.004") is available if the protrusion checks indicate a need for it. The thicker fire ring can be identified by a blue marking stripe.

Refer to Pages L-4 and L-5 for the procedure to follow when installing the fire ring cylinder head gasket.

REMOVAL AND INSTALLATION OF CYLINDER HEAD AND COMPONENTS

CAUTION
DO NOT OVER
TIGHTEN COVER NUTS

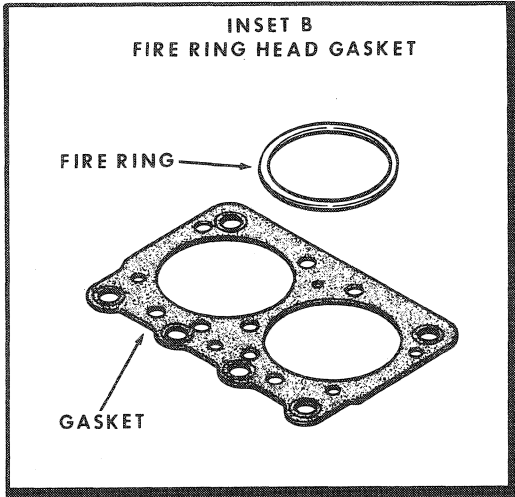
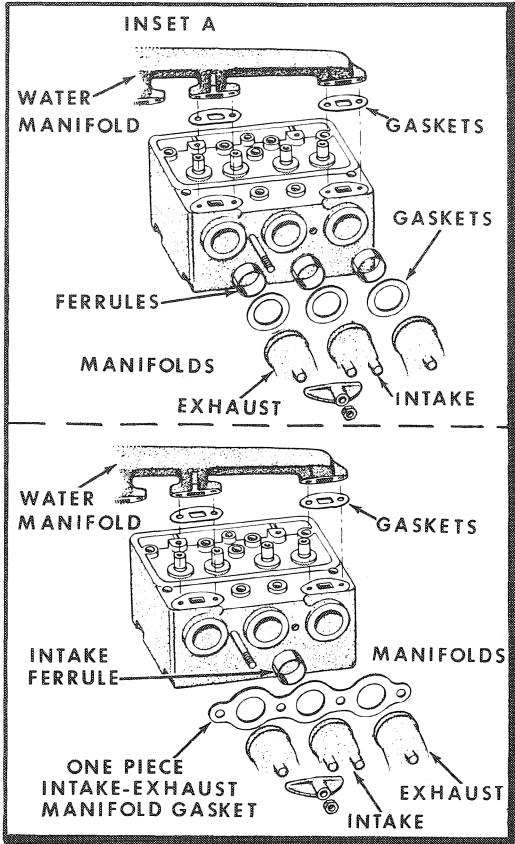
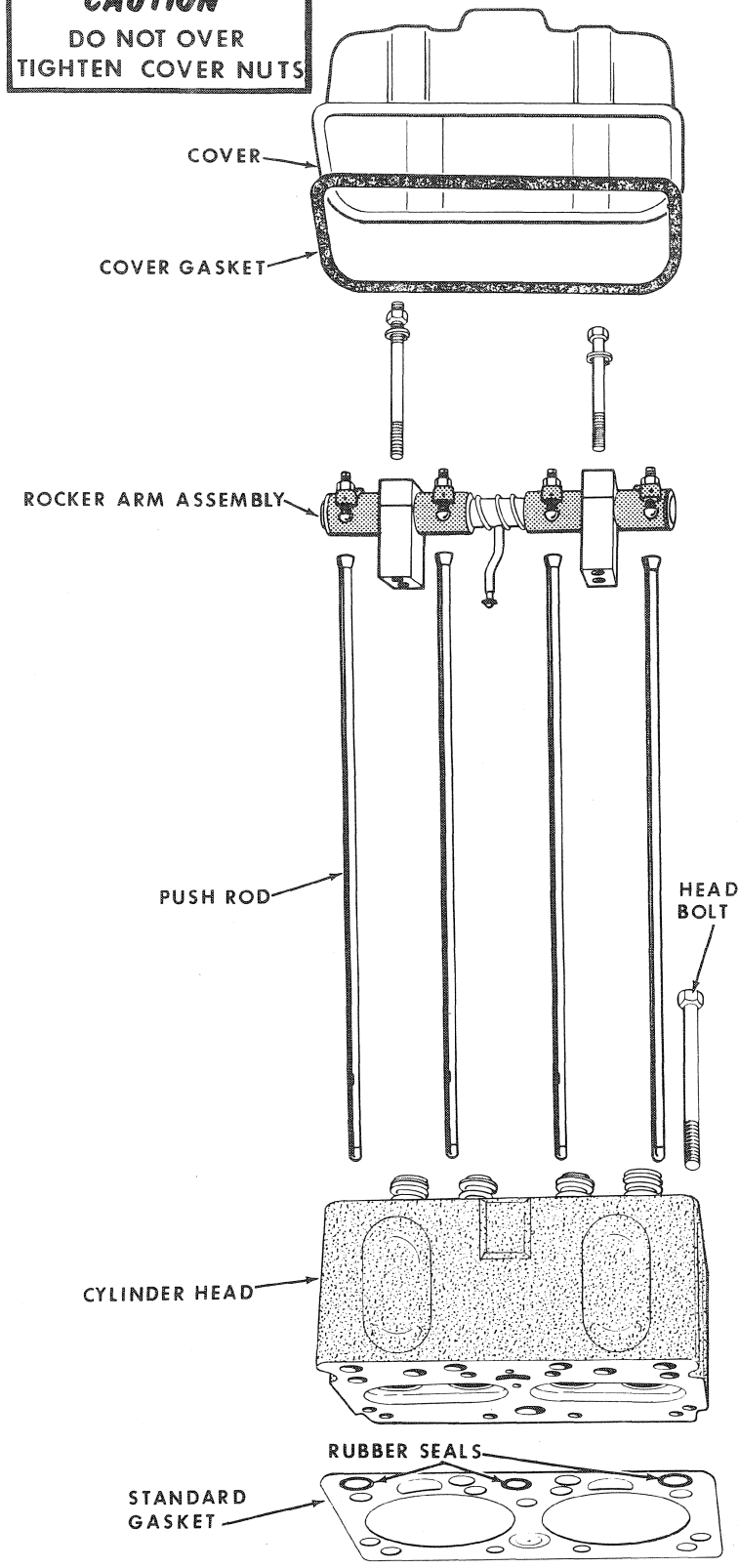
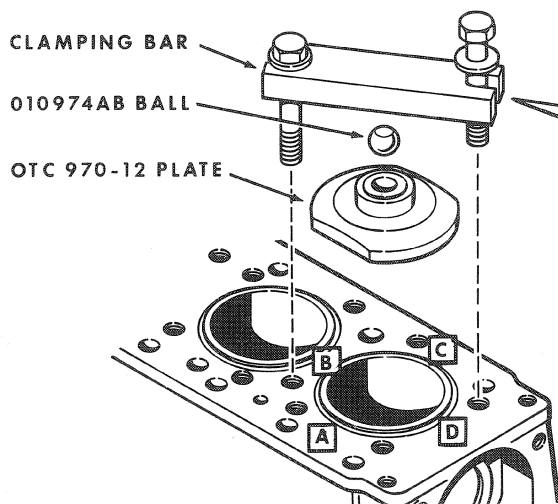

Figure L-1

Inspection and Installation Fire Ring Gaskets(Continued)

The following procedure must be followed when installing the fire ring head gasket:

1. Clean the top surface of the block and sleeve flange carefully. All traces of carbon and other deposits must be removed. During the final cleaning operation, the use of a rag dampened in solvent is recommended.
2. Using a small stone, remove any small burrs in the areas to be measured so that accurate readings can be obtained.



MEASURE SLEEVE PROTRUSION AT POINTS A, B, C, AND D.

Figure L-2

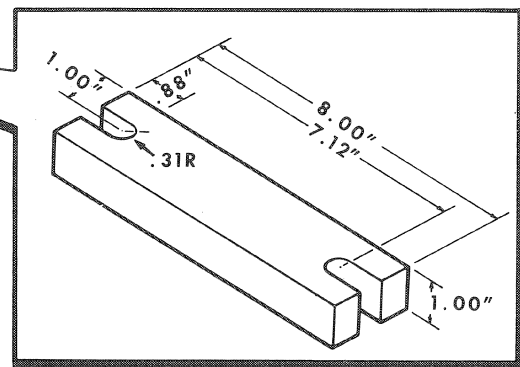

4. Either a magnetic base dial indicator or a depth micrometer can now be used to determine the cylinder sleeve protrusion as indicated in Figure L-3. Refer to chart, Figure L-5, to make sure the correct fire ring is used.

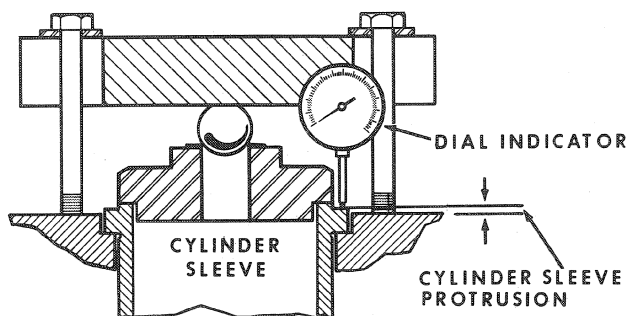

Figure L-3

5. Install cylinder head gaskets. **IMPORTANT** Two of the capscrew holes in the gasket are slightly smaller and act as guides to position the gasket as well as the fire ring,

3. Using plate OTC970-12* from cylinder sleeve puller OTC970*, 010974AB ball and clamping bar, clamp the cylinder sleeve in place, Figure L-2. Torque the hold down capscrews evenly to 50 foot pounds. **NOTE** Refer to Figure L-2 for clamping bar dimensions.

*These tools are available through local Owatonna Tool Dealers or the Owatonna Tool Co., Owatonna, Minnesota.

- Figure L-4. Regular line-up studs could be used for most engines. In some instances it is very difficult to install the

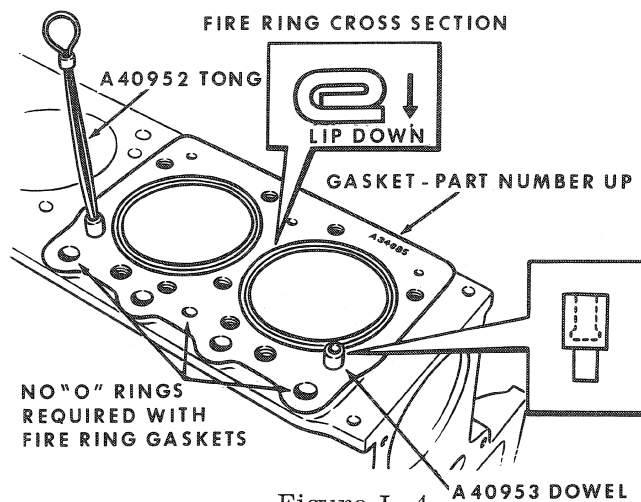

Figure L-4

rear cylinder head due to the limited space in which to place the head when lowering it down over the long guide studs.

Inspection and Installation(Continued)

CYLINDER SLEEVE PROTRUSION	USE STANDARD FIRE RING	USE OVERSIZE (THICKNESS) FIRE RING
BOTH SLEEVES UNDER ONE HEAD FLUSH TO .002"		X
BOTH SLEEVES UNDER ONE HEAD .002" OR OVER BUT LESS THAN .0025" BETWEEN SLEEVES	X	
BOTH SLEEVES UNDER ONE HEAD OVER .0025" DIFFERENCE BETWEEN SLEEVES	ON THE HIGH SLEEVE	ON THE LOW SLEEVE

Figure L-5

6. For difficult installations, the use of dowel pins and a tong are recommended and can be purchased through a local Snap-On Tool Dealer or J.I. Case Central Parts Dept. under the following part numbers.

Snap-On Tool No.	Case Part No.
CF83-1 Tong	A40952
CF83-4 Dowel	A40953

7. Install the fire rings with the lip downwards, Figure 4. **NOTE** Fire ring gaskets must be installed dry.

8. Carefully clean the cylinder heads as described in No. 1. If evidence of fretting or erosion exist in the area of the fire ring contact or if the head is warped more than .005", the head must be resurfaced.

9. Install cylinder heads and several bolts, then remove the A40953 dowels using A40952 tong and install all the bolts.

STANDARD AND FIRE RING HEAD GASKETS

10. Install intake and exhaust manifold ferrules and new gaskets. **NOTE** When the manifolds are designed for the one piece manifold gasket, the ferrules are used only in the intake ports. Refer to Page L-3, inset A. Install the intake and exhaust manifolds and torque to proper torque. Refer to Specification Section.

11. Torque cylinder head bolts or nuts to the proper sequence illustrated in Figure L-6. The three torquing steps recommended are 50 foot pounds, 100 foot pounds and finally 150 foot pounds.

12. Install the push rods in their original location. Reconnect the fuel line, throttle control and choke control. Reconnect the

spark plug wires. Refer to Page L-14 for proper firing order.

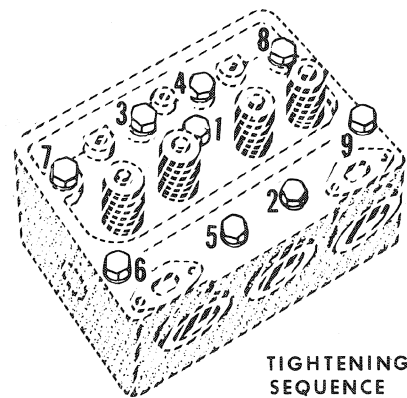

Figure L-6

13. Install the rocker arm assemblies in their original location.

14. Adjust the valve tappet clearance, refer to Page L-14.

15. Fill cooling system and start engine. Check that the rocker arms are receiving lubrication.

16. Run engine for approximately one (1) hour, under load if possible, to thoroughly warm up the engine and seat the head gaskets.

17. Stop the engine and retorque the cylinder head bolts or nuts to 150 foot pounds while the engine is still hot. Check and readjust the tappet.

18. Clean the rocker arm covers and remove the old gasket. Install new gaskets and seals; then install covers. Refer to Specification Section for proper torque. Do not over torque the valve cover nuts.



Suggest:

If the above button click is invalid.

Please download this document

first, and then click the above link

to download the complete manual.

Thank you so much for reading

DISASSEMBLY OF THE ROCKER ARMS **(Refer to Figure L-7)**

Remove the rocker arm shaft bracket studs (15) and bolts (16). Remove and tag shaft assemblies for installation.

Unscrew the oil tube (1) and discard the "O" ring (2). Remove the snap rings (3), spacer washer (5) and keep count of the number of washers at each end of the shaft. Tag each rocker arm for original location. Remove the exhaust rocker arms (6) and the shaft brackets (7) from each end of the shaft.

Remove the intake rocker arms (8) and the shaft spring (9). In rocker shafts not reamed with stamped steel cup plugs, inset "C", remove the plugs (10) by using a rod and driving one plug clear thru the shaft. This will

also clean out any sludge that has accumulated inside of the shaft. To remove cup plugs (10) in reamed rocker shafts, Inset "C" drill hole thru the plug and remove. Rocker shafts with aluminum type plugs, Inset "D" are permanent type. The plugs are not replaceable. Replacement shafts have these plugs installed at the factory.

Remove the push rods and store them in a rack or holder so they can be installed in their original location.

Remove the oil wick (11) from each exhaust rocker arm of the cast iron type and discard. Remove the bushing (12) from the cast rocker arm if it is worn using an Arbor (See Inset A).

INSPECTION **(Refer to Figure L-7)**

Inspect the shaft spring for proper tension and broken coils. Refer to "Specification" Section. Inspect the rocker arm shaft for excessive worn spots on the bottom side of the shaft. Replace shaft if worn condition exists.

Inspect the rocker arm bushings by installing each rocker arm on the shaft in its proper location. The rocker arm must be free on the shaft without any side "wobble".

In the cast rocker arms if any is noted, replace the bushing. In the stamped rocker arms the bushing is not replaceable. Replacement rocker arms are purchased complete with bushings. Inspect the valve contact area on the rocker arm for wear. Replace if worn. Inspect the tappet adjusting screw for wear marks or pitting. Inspect the push rods for straightness, cracked or worn ends.

ASSEMBLY **(Refer to Figure L-7)**

Clean all parts thoroughly. Place new bushing on Arbor and press into the cast rocker arm so the bushing (12) is evenly centered in the rocker arm and the oil hole is lined up with the oil hole in the rocker arm, (See Inset A). Check the bushing for high or rough spots and if they exist, they should be honed out. Install new oil wick (11) in the cast iron exhaust rocker arm. Lubricate each part with engine oil as they are installed.

Install a shaft spring (9) and two intake rocker arms (8) on the shaft (4). When installing the cast rocker arms, the adjusting screw and the shaft oil hole must be on the same side. (See Inset A).

When installing the stamped steel rocker arms, the adjusting screw and the shaft oil hole must be on opposite sides (See inset B).

Install the shaft brackets (7) on the shaft with the split side toward the push rod side

of the engine. Install the exhaust rocker arms (6) on the shaft. Install the same number of spacer washers (5) that were removed.

Install the snap rings (3) at each end of the shaft. Check the rocker arms for free movement. Install the oil tube (1) with new "O" ring (2). Install the push rods in their original location if they were removed. Install the adjusting screws (13) and lock nuts (14) if they were removed.

Install the rocker arm and shaft assembly on the cylinder head. Make sure all the push rods are engaged with the adjusting screws. Install the bracket studs (15) and bolts (16). Torque studs and bolts 54 to 64 foot pounds. Check that the oil tube is in the oil hole in the cylinder head. Check exhaust rocker arms for excessive end play. One or more spacer washers (5) can be used between the rocker arm (6) and snap ring (3) to remove the excessive end play. Check and adjust the tappet clearance. (Refer to Page L-14).

<https://www.ebooklibonline.com>

Hello dear friend!

Thank you very much for reading.

Enter the link into your browser.

The full manual is available for immediate download.

<https://www.ebooklibonline.com>