

# W8C, W9C, W10C LOADERS

## TABLE OF CONTENTS

SERIES/SECTION	SECTION NO.	FORM NO.
10 SERIES - GENERAL Specifications for Case Engines . . . . .	CC	9-74562
20 SERIES - ENGINE Cylinder Heads, Valve Systems, Rocker Arms, Decompressor on Diesel Engines . . . . .	K	9-76972
Cylinder Heads, Valve Systems, Rocker Arms on Spark Ignition Engines . . . . .	L	9-76962
Servicing Assemblies Contained in Engine Block . . . . .	M	9-75222
Water Pump . . . . .	3M	9-77461
Spark Ignition Governor . . . . .	4M	9-76751
Governor Linkage . . . . .	---	9-77511
30 SERIES - FUEL SYSTEM Fuel Injectors, Fuel Injection Pump . . . . .	I	9-75421
62 Series Gasoline Carburetor . . . . .	NN	9-74561
40 SERIES - HYDRAULICS "25X" Series Gear Type Hydraulic Pump . . . . .	3B	9-74561
Loader Hydraulic System . . . . .	4D	9-99795
50 SERIES - STEERING VTM Vane Type Power Steering Pump . . . . .	PP	9-74561
Combined Unit Power Steering Cylinder and Valve, Steering Linkage, Steering Gear Box . . . . .	Q	9-74563
60 SERIES - POWER TRAIN Single Reduction Differentials, Universal Joints, Drive Shafts . . . . .	T	9-74561
Planetaries and Axles (PS and PR 100, 150, and 200 Series) . . . . .	U	9-74561
C-270 Series Torque Converter . . . . .	X	9-74563
2000 Series Transmission . . . . .	Y	9-74563
70 SERIES - BRAKES H Series Brake Shoes, Drums, Wheel Cylinders . . . . .	W	9-75151
"01" Brake Cylinder, Brake Shoes, Drums . . . . .	W	9-74562
Transmission Cut-Out (Lever Operated) . . . . .	W, Supp't 2	9-74562
Hydrovac Brake System . . . . .	3W	9-74563
80 SERIES - ELECTRICAL Electrical System, Cranking Circuit, Charging Circuit . . . . .	F	9-75202
Electrical System, Charging Circuit, Cranking Circuit, Ignition System . . . . .	3F	9-76721
Alternator and Wiring Diagrams with Motorola Alternator . . . . .	4F	9-99785

Reprinted

# SECTION



## SPECIFICATIONS FOR CASE

**W8B-A 401 DIESEL ENGINE**

**W8B-A 377 GASOLINE ENGINE**

**W9B-A 401 DIESEL ENGINE**

**W9B-A 377 GASOLINE ENGINE**

**W10B-A 401 DIESEL ENGINE**

**W10B-A 377 GASOLINE ENGINE**

**W10-A 401 DIESEL ENGINE**

**W12-A 451 DIESEL ENGINE**

The Specifications are the Same Unless Otherwise Indicated

# diesel engines

## CC-2 A401 AND A451 ENGINE SPECIFICATIONS

Type	CASE Full Diesel, 6 Cylinder 4 Stroke Cycle Valve-in-Head Engine.
Cylinder Heads	Multiple Cylinder Heads can be removed individually for Servicing(2 cylinders per head).
Firing Order	1-5-3-6-2-4
Bore	A401 4-1/8 Inches A451 4-3/8 Inches
Stroke	5 Inches
Piston Displacement	A401 401 Cubic Inches A451 451 Cubic Inches
Compression Ratio	15 to 1
Oil Filter, Crankcase	Replaceable Full Flow Element Type.
Method of Starting Diesel Engine	Engine Starts on Diesel Fuel (Electric Starting Motor).
Decompressor	Holds Exhaust Valves Open so Engine can be Cranked for Servicing.
Exhaust Valve Rotators	Positive Type

### Maximum Compression Pressures ENGINE WARMED UP TO OPERATING TEMP. AND RUNNING AT 1600 RPM

Altitude	Sea Level	1000 ft.	2000 ft.	3000 ft.	4000 ft.	5000 ft.
Compression Pressure	480 to 510 PSI	455 to 485 PSI	435 to 465 PSI	415 to 425 PSI	395 to 425 PSI	375 to 405 PSI

Allowable Variance Between Cylinders - 25 Pounds Pressure at 1600 RPM

### CYLINDER SLEEVES

Type	Replaceable Wet Type:Two Rubber O-Ring Seals carried on each sleeve.
Inside Diameter of Sleeve Bore	A401 4.125 to 4.126 Inches. Replace Sleeve when inside Diameter below Top Ring Ridge Exceeds 4.133. A451 4.375 to 4.376 Inches. Replace Sleeve when inside Diameter below Top Ring Ridge Exceeds 4.383 Inches.
Piston Clearance in Sleeve(At Skirt)	A401 .0045 to .0055 Inch A451 .0045 to .0065 Inch

### PISTON AND PISTON PINS

Piston Material	A401 Special Alloy Iron;Parco-Lubrized A401(W9 Series B) Aluminum A451 Aluminum
Piston Weight (Less Pin)	A401 4.742 to 4.758 Pounds A401(W9 Series B) 3.400 Pounds A451 3.937 to 3.939 Pounds
Diameter of Piston at Top	A401 4.106 to 4.109 Inches A401(W9 Series B) 4.092 to 4.096 Inches A451 4.341 to 4.345 Inches
Diameter of Piston at Skirt	A401 4.1205 to 4.1215 Inches A401(W9 Series B) 4.1155 to 4.1201 Inches A451 4.3675 to 4.3685 Inches
Piston Pins	Full Floating Type:Held in Position with Snap Rings in Piston. Replaceable Bronze Bushing in Connecting Rod.
Piston Pin Length	A401 3.395 to 3.405 Inches A401(W9 Series B) 3.485 to 3.490 Inches A451 3.670 to 3.675 Inches
Piston Pin Diameter	A401 1.3583 to 1.3586 Inches

A401(W9 Series B)	1.4994 to 1.4995 Inches
A451	1.4994 to 1.4995 Inches

Piston Pin Fit in Piston	A401 .0007 to .0012 Inch. When Pin is lubricated with Light Engine Oil and held upright in Vise, Weight of Piston should allow it to slide slowly into position over Pin. A401(W9 Series B) .0000 to .0003 Inch A451 .0000 to .0003
--------------------------	---

Piston Pin Fit in Connecting Rod Bushing	A401 .0004 to .0011 Inch A401(W9 Series B) .0009 to .0014 Inch A451 .0005 to .0010 Inch
--	---

### PISTON RINGS

Rings Per Piston	4- (3 Compression and 1 Oil).
Compression Rings (Top 3)	1st (Top ) Ring Chromium Plated; Tapered Face: Top Marked. 2nd and 3rd Rings Relief Indicates Bottom Side Width of Ring (All 3) .0930 to .0935 Inch Ring End Gap(All 3)when Compressed in 4.125 Inch Cylinder A401 .013 to .023 Inch Ring End Gap(All 3) when Compressed in 4.375 Inch Cylinder A451 .013 to .025 Inch Side Clearance in Groove of 1st (Top)Ring A401 .003 to .0045 Inch A451 .0045 to .0060 Inch Side Clearance in Groove of 2nd and 3rd Ring .0025 to .004 Inch Oil Ring To install Replacement Ring, Follow Instructions Packed with Rings. Width of Rings (Original Equipment) A401 .2455 to .2485 Inch A451 .2470 to .2490 Inch Replacement Ring .2441 to .2474 Inch Side Clearance in Groove(Original Equipment) A401 .0025 to .0065 Inch A451 .0025 to .0085 Inch Replacement Ring A401 .0036 to .0079 Inch A451 .0025 to .0085 Inch

### CONNECTING RODS

Connecting Rod Bushing	Replaceable Bronze Bushing Replacement Bushing must be Reamed. A401 Use 1.3590 to 1.3594 Reamer A401 (W9 Series B) Use 1.5004 to 1.5008 Reamer A451 Use 1.5004 to 1.5008 Reamer
------------------------	--

Piston Pin Hole Diameter in Rod (Without Bushing)	A401 1.483 to 1.485 Inches A401(W9 Series B) 1.686 to 1.688 Inches A451 1.686 to 1.688 Inches
---	---

Inside Diameter of Piston Pin Bushing in Rod	1.3590 to 1.3594 Inches; Install New Bushing if inside Diameter Exceeds 1.363 Inches. 1.5004 to 1.5008 Inches.Install New Bushing if inside Diameter Exceeds 1.504 Inches.
--	---

Connecting Rod Bearing	Replaceable, Precision, Steel Backed Copper Lead Alloy Liners.
------------------------	--

Connecting Rod Capscrews	Self Locking Type, No. Lock Wires Required May be used More Than Once.
--------------------------	--

Connecting Rod Length (Center to Center Between Pin Hole and Bearing Journal Hole)	10.499 to 10.501 Inches
--	-------------------------

Bearing Liner Width	1-5/8 Inch
---------------------	------------

Diameter of Crankshaft Journal Hole in Rod(Without Liner)	2.9005 to 2.9010 Inches
---	-------------------------

Inside Diameter of Bearing Liner(Standard Liner in place in Rod and Capscrews Tight)	2.7503 to 2.7518 Inches
--	-------------------------

Diameter of Crankshaft Rod Journal	2.748 to 2.749
------------------------------------	----------------

**<https://www.ebooklibonline.com>**

Hello dear friend!

Thank you very much for reading.

Enter the link into your browser.

The full manual is available for immediate download.

**<https://www.ebooklibonline.com>**

Clearance Between Rod Bearing and Crankshaft Journal ----- .0013 to .0038 Inch; Install New Bearing Liners When Clearance Exceeds .006 Inch.

Undersize Bearing Liners Available for Service ----- .002, .010, .020, .030 Inch

Allowable Connecting Rod Bearing End Play ----- .005 to .012 Inch

**CRANKSHAFT AND MAIN BEARINGS**

Crankshaft ----- Balanced; Drilled to Provide Pressure Lubrication to Main and Connecting Rod Bearings.

Type Main Bearings ----- Replaceable, Precision, Steel Backed Copper - Lead Alloy Liners.

Bearing Capscrews ----- Self Locking Type, No Lock Wires Required May Be Used More Than Once.

Bearing Taking End Thrust ----- 5th(Two Replaceable Bronze Thrust Washers.)

Crankshaft End Play(Measured at No. 5 Main Bearing) ----- .004 to .012 Inch; Install New Thrust Washers if End Play Exceeds .020 Inch.

Oversize Thrust Washers for End Play Available for Service ----- .006 Inch

Connecting Rod Bearing Journal Diameter----- 2.748 to 2.749 Inches

Main Bearing Journal Diameter ----- 2.998 to 2.999 Inches

Crankshaft Main and Connecting Rod Journal Bearings out of Round ----- Maximum .001 Inch

Inside Diameter of Main Bearing Liners (In Place and Capscrews Tight)----- 3.0006 to 3.0026 Inches

Clearance Between Main Bearing Liner and Journal ----- .0016 to .0046 Inch; Install New Bearing Liner when Clearance Exceeds .0065 Inches.

Width of 1st, 3rd 5th and 7th Main Bearing Liners ----- 2-7/32 Inches

Width of 2nd, 4th and 6th Main Bearing Liners ----- 1-5/32 Inches

Width Between Crankshaft Main Bearing Cheeks

A. 3rd, 7th ----- 2.620 to 2.630 Inches

B. 2nd, 4th and 6th ----- 1.5575 to 1.5675 Inches

C. 5th ----- 2.624 to 2.626 Inches

Width Between Crankshaft Rod Bearing Journal Cheeks ----- 1.9975 to 2.0025 Inches

Undersize Main Bearing Liners Available for Service ----- .002, .010, .020, .030 Inch

Crankshaft Main Bearing Journals Should Be

2.988-2.989 Inches for .010 Inch Undersize Bearing

2.978-2.979 Inches for .020 Inch Undersize Bearing

2.968-2.969 Inches for .030 Inch Undersize Bearing

Undersize Connecting Rod Bearing Shells Available for Service ----- .002, .010, .020, .030 Inch

Connecting Rod Crankshaft Journals Should Be Ground to----- 2.738-2.739 Inches for .010 Inch Undersize Bearing

2.728-2.729 Inches for .020 Inch Undersize Bearing

2.718-2.719 Inches for .030 Inch Undersize Bearing

**CAMSHAFT BUSHINGS**

Number of Bearing Surfaces on Camshaft ----- 5

Type Bushing ----- Replaceable, Precision, Steel Backed Babbitt

Bushing Lubrication ----- Pressure Lubricated from Oil Pump; Camshaft Drilled to Provide Pressure Lubrication to Valve Rocker Arm Assembly, and to Timing Gear Train.

Diameter of Camshaft at Each Bearing Surface

A401 Camshaft No. 6310A (use w/Welch type Camshaft Plug)----- 2.121 to 2.122 Inches

A401 Camshaft No. A21428 (use w/Welch type Camshaft Plug)----- 2.246 to 2.247 Inches

A401 Camshaft No. A23486 (use w/cup type Camshaft Plug) ----- 2.246 to 2.247 Inches

A401 Camshaft No. A23513 (use w/cup type Camshaft Plug)----- 2.246 to 2.247 Inches

A451 ----- 2.246 to 2.247 Inches

**Inside Diameter of Each Bushing (Measured when in Place in Block)**

A401 Camshaft No. 6310A (use w/Welch Type Camshaft Plug) ----- 2.1234 to 2.1264 Inches

A401 Camshaft No. A21428 (use w/Welch type Camshaft Plug)----- 2.2484 to 2.5414 Inches

A401 Camshaft No. A23486 (use w/cup type Camshaft Plug) ----- 2.2484 to 2.5414 Inches

A401 Camshaft No. A23513 (use w/cup Type Camshaft Plug) ----- 2.2484 to 2.5414 Inches

A451----- 2.2484 to 2.5414 Inches

No. 1(Front) Bushing Length ----- 1-21/32 Inches

No. 2, 3 and 4 Bushing Lengths ----- 1-7/16 Inches

No. 5 Bushing Length(w/Welch Type Camshaft Plug) ----- 1-7/16 Inches

No. 5 Bushing Length(w/cup type Camshaft plug)----- 1-5/32 Inches

Camshaft End Play ----- Automatically Taken Up by Spring Loaded Thrust Button in Front End of Camshaft. Camshaft Washer Provided Between Drive Gear and Front Bearing.

**Camshaft Washer**

Outside Diameter ----- 3.240 to 3.260 Inches

**Inside Diameter**

A401 Camshaft No. 6310A (Use w/Welch type Camshaft Plug) ----- 2.125 to 2.135 Inches

A401 Camshaft No. A21428 (Use w/Welch type Camshaft Plug)----- 2.250 to 2.260 Inches

A401 Camshaft No. A23486 (Use w/cup type Camshaft Plug) ----- 2.250 to 2.260 Inches

A401 Camshaft No. A23513 (Use w/cup type Camshaft Plug)----- 2.250 to 2.260 Inches

A451----- 2.250 to 2.260 Inches

Thickness ----- .1225 to .1275 Inch

**VALVE PUSH ROD LIFTERS**

Type ----- Mushroom Type

**Outside Diameter of End that Projects into Block**

A401 Camshaft No. 6310A (Use w/Welch type Camshaft Plug)----- .8095 to .8105 Inches

A401 Camshaft No. A21428 (Use w/Welch type Camshaft Plug)----- .8097 to .8102 Inches

A401 Camshaft A23513 (Use w/cup type Camshaft Plug)----- .8097 to .8102 Inches

A451 ----- .8097 to .8102 Inch

Diameter of Bore in Block for Lifter ----- .8115 to .8130 Inch

Oversize Lifter Available for Service ----- .010 In. Oversize Lifter

Bore in Block Must Be Reamed to----- .8215 to .8225 Inch for .010 Inch Oversize Lifter.

**VALVES**

**Valve Tappet Clearance**

A401 Intake ----- .012 Inch, Engine Cold

Exhaust ----- .020 Inch, Engine Cold

A401(W9 Series B) ---- .025 In., Engine Cold (Both Intake and Exhaust)

A451 ----- .025 In., Engine Cold(Both Intake and Exhaust)

**Exhaust Valves**

Angle of Valve Face ----- 44 Degrees

Maximum Valve Face Runout ---- .002 Inch as Determined with a Dial Indicator.

Diameter of Valve Stem--- .4000 to .401 Inch. Install New Valve if there is More than .002 Inch Difference in Diameter at any Point on Stem.

Inside Diameter of Valve Guide----- .4045 to .4055 Inch(After Assembly).

Valve Stem Clearance in Guide ----- .0035 to .0055 Inch

**CC-4****Exhaust Valve Seat Insert**

Seat Angle ----- 45 Degrees  
 Seat Width ----- .073 to .084 Inch  
 Insert Height ----- .312 to .317 Inch  
 Outside Diameter of Insert  
 A401 ----- 1.640 to 1.641 Inches  
 A451 ----- 1.722 to 1.723 Inches  
 Inside Diameter of Insert  
 A401 ----- 1.323 to 1.333 Inches  
 A451 ----- 1.401 to 1.411 Inches  
 Maximum Allowable Seat Runout ----- .003 Inch as Determined  
 with a Dial Indicator

**Intake Valves**

Angle of Valve Face ----- 44 Degrees  
 Maximum Valve Face Runout ----- .002 Inch as Determined  
 with a Dial Indicator.  
 Diameter of Valve Stem ----- .402 to .403 Inch Install New Valve  
 if there is More than .002 Inch Difference in  
 Diameter at any Point on Stem.  
 Inside Diameter of Valve Guide ---- .4045 to .4055 Inch.(After Assembly)  
 Stem Clearance in Guide ----- .0015 to .0035 Inch

**Intake Valve Seat**

Seat Angle ----- 45 Degrees.  
 Seat Width  
 A401 ----- .086 to .096 Inch  
 A451 ----- .070 to .086 Inch

**Exhaust Valve Guides**

Length ----- 3-7/32 Inches  
 Outside Diameter ----- .7510 to .7515 Inch  
 Inside Diameter ----- .4045 to .4055 Inch.(After Assembly)  
 Valve Stem Clearance in Guide ----- .0035 to .0055 Inch  
 Distance Above Head Guide Must Protrude---1-1/16 Inches, Press Fit

**Intake Valve Guides**

Length ----- 4-3/8 Inches  
 Outside Diameter ----- .7510 to .7515 Inch  
 Inside Diameter ----- .4045 to .4055 Inch(After Assembly)  
 Valve Stem Clearance in Guide ----- .0015 to .0035 Inch  
 Distance Above Head  
 Guide Must Protrude ----- 1-1/16 Inches, Press Fit

**VALVE SPRINGS**

Free Length ----- Approximately 2.438 Inches  
 Spring Pressure at Compressed Height of  
 1-31/64 Inches (Valve Open)----- 102 Pounds; Install New Spring if  
 Pressure is Less than 92 Pounds.  
 Spring Pressure at Compressed Height of  
 1-15/16 Inches(Valve Closed)--- 45 Pounds; Install New Spring if Pres-  
 sure is Less than 41 Pounds.

**ROCKER ARM ASSEMBLY**

Rocker Arm Bushing ----- Replaceable Precision Bronze Bushing  
 Number of Bushings ----- 12  
 Lubrication ----- Pressure Lubricated; Crankcase Oil to  
 Rocker Arms Metered By Camshaft.  
 Oil Holes in Rocker Arm Shaft -----Oil Holes must Face Push Rod  
 Side of Engine Only. Shaft Cannot Be Rotated.  
 Positioning of Exhaust  
 Valve Rocker Arms ----- Spacer Washers Position Exhaust Valve  
 Rocker Arm and Eliminate End Play without Binding.

Outside Diameter of  
 Rocker Arm Shaft ----- .872 to .873 Inch

Inside Diameter of Rocker  
 Arm Bushing ----- .8745 to .8755 Inch

**OIL PUMP**

Type ----- Positive Displacement, Gear Type Pump;  
 Driven Off Camshaft.

Pressure Relief Valve -----Maintains 40 to 45 Pounds Full Pres-  
 sure(Oil Warm,Engine Operating at Full Governed  
 Speed)Relief Valve is Adjustable.

**WATER PUMP AND THERMOSTAT**

Type of System -----Pressurized Thermostat Controlled  
 By-Pass Type; Forced Circulation(Pump)

Type Pump ----- Impeller Vane Type

Radiator ----- Heavy Duty Fin and Tube Type

Temperature Control ----- By-Pass Type Thermostat

**FUEL SYSTEM**

Injection Pump -----Robert Bosch,Type PES Multiple Plunger Pump

Direction of Pump Rotation ----- Counter-Clockwise

Pump Mounting ----- Left Hand Side of Engine

Pump Drive ----- Gear Driven from Camshaft Gear at Camshaft Speed

Injection Pump Drive Lubrication ----- Pressure Lubricated From  
 Front Camshaft Bearing.

Injection Pump Drive Shaft Diameter ----- 1.3700 to 1.3705 Inches

Normal Clearance Between  
 Drive Shaft and Bushings ----- .001 to .002 Inch

Number of Drive  
 Shaft Bushings -----2- These Bushings are Not Re-  
 placeable. A Replacement Drive Housing with  
 Bushings in Place Aligned and Fine Bored is Provided.

Injection Pump Drive  
 Shaft End Play ----- Automatically Taken Up By a Spring  
 Loaded Thrust Button on Front End of Drive Shaft.  
 Thrust Washers Provided Between Front Drive Gear  
 and Drive Shaft Housing.

**Thrust Washer**

Outside Diameter ----- 2.085 to 2.105 Inches

Inside Diameter ----- 1.3725 to 1.3825 Inches

Thickness ----- .1225 to .1275 Inch

Timing Marks on Engine----- Timing Marks Located on Crankshaft  
 Pulley Flange(0 through 5 and 20 through 35  
 Degrees Before Top Dead Center). Pointer  
 Located on Timing Gear Cover.

Fuel Injectors ----- Robert Bosch Pintle Type;Opening Pressure  
 1950 to 2050 Pounds Per Square Inch.

Governor ----- Mechanical Variable Speed Fly-Weight Centrifugal  
 Type; Integral Part of Injection Pump.

**Fuel Filters**

Fuel Tank Breather Air Filter -----Located in Fuel Tank Filler Cap

Fuel Tank Water Trap ----- Located in Base of Fuel Tank

1st Stage Fuel Filter ----- Replaceable Element Type

2nd Stage Fuel Filter ----- Replaceable Element Type

Final Fuel Filter ----- Replaceable Sealed "Can"Type Filter.

## A377 ENGINE SPECIFICATIONS

Type ----- CASE 6 Cylinder, 4 Stroke Cycle, Valve-In-Head Engine.

Cylinder Heads -----Multiple Cylinder Heads can be removed individually for Servicing (2 Cylinders per head).

Firing Order ----- 1-5-3-6-2-4

Bore ----- 4 Inches

Stroke ----- 5 Inches

Piston Displacement ----- 377 Cubic Inches

Compression Ratio ----- 6.8 to 1

Maximum Compression at Cranking Speed (150 RPM) Engine Warmed up to Operating Temperature -----140 PSI at Sea Level

Allowable Variance Between Cylinders ----- 15 Pounds Pressure

Oil Filter, Crankcase-----Replaceable Full Flow Element Type.

Exhaust Valve Rotators----- Positive Type

Ignition ----- Distributor

### CYLINDER SLEEVES

Type ----- Replaceable Wet Type; Two Rubber O-ring Seals Carried on each sleeve.

Inside Diameter of Sleeve Bore ----- 4.00 to 4.001 Inches, Replace Sleeve when Inside Diameter Below Top Ring Ridge Exceeds 4.008 Inches.

Piston Clearance in Sleeve (At Skirt)----- .0035 to .0045 Inches

### PISTON AND PISTON PINS

Piston Material ----- Aluminum

Piston Weight (less Pin)----- 2.205 to 2.214 Pounds

Diameter of Piston at Top ----- 3.964 to 3.968

Diameter of Piston at Top of Skirt (Measured Immediately Below Oil Ring, Across Thrust Faces)----- 3.996 to 3.997

Piston Pins ----- Full Floating Type; Held in Position with Snap Rings in Piston; Replaceable Bronze Bushing in Connecting Rods.

Piston Pin Length----- 3.395 to 3.405 Inches

Piston Pin Diameter ----- 1.3583 to 1.3586 Inches

Piston Pin Fit in Piston ----- .0001 to .0003 Inch

Piston Pin Fit in Connecting Rod Bushing ----- .0004 to .0011 Inch

### PISTON RINGS

Rings Per Piston ----- 4 - (3 Compression and 1 Oil)

Compression Rings (Top 3)

1st (Top) Ring ----- Chromium Plated; Relief Indicates Top Side

2nd and 3rd Rings ----- Tapered Face, Top Marked

Width of Rings (All 3)----- .0930 to .0935 Inch

Ring End Gap (All 3) When Compressed in 4.000 Inch Cylinder ----- .013 to .023 Inch

Side Clearance in Groove of 1st (top) Ring ----- .0025 to .0040 Inch

Side Clearance in Groove of 2nd and 3rd Ring ---- .0020 to .0040 Inch

Oil Ring ----- To install Replacement Ring, Follow Instructions Packed with Rings.

Width of Ring (Both Original and Replacement)----- .2485 to .2490 Inch

Ring End Gap when Compressed in 4.00 Inch Cylinder ----- .002 to .0035

Side Clearance in Groove (Original Equipment)---- .0025 to .0065 Inch (Replacement Ring)----- .0036 to .0079 Inch

## CC-5

### CONNECTING RODS

Piston Pin Bushing ----- Replacement Bronze Bushing, Ream in place. Use 1.3590 to 1.3594 Reamer.

Piston Pin Hole Diameter in Rod (Without Bushing)----- 1.483 to 1.485 Inches

Inside Diameter of Piston Pin Bushing in Rod ----- 1.3590 to 1.3594 Inches; Install New Bushing if Inside Diameter Exceeds 1.363

Connecting Rod Bearing ----- Replaceable, Precision Steel Backed, Copper Lead Alloy Liners.

Connecting Rod Capscrews ----- Self Locking Type, No Lock Wire Required—May be Used More Than Once.

Connecting Rod Length (Center to Center Between Pin Hole and Bearing Journal Hole -----10.499 to 10.501 Inches

Bearing Liner Width ----- 1-5/8 Inch

Diameter of Crankshaft Journal Hole in Rod (Without Liner )----- 2.9005 to 2.9010 Inches

Inside Diameter of Bearing Liner (Standard Liner in Place in Rod and Capscrews Tight) ----- 2.7503 to 2.7518 Inches

Diameter of Crankshaft Rod Journal ----- 2.748 to 2.749 Inches

Clearance Between Rod Bearing and Crankshaft Journal ----- .0015 to .0036 Inch; Install New Bearing Liners When Clearance Exceeds .006 Inch.

Undersize Bearing Liners Available for Service ----- .002, .010, .020, .030 Inch

Allowable Connecting Rod Bearing End Play ----- .005 to .012 Inch

### CRANKSHAFT AND MAIN BEARINGS

Crankshaft ----- Balanced Drilled to Provide Pressure Lubrication to Main and Connecting Rod Bearings

Type Main Bearings ----- Replaceable Precision, Steel Backed, Copper Lead Alloy Liners.

Bearing Capscrews ----- Self Locking Type, No Lock Wires Required - May Be Used More Than Once

Bearing Taking End Thrust ----- 5th (Two Replaceable Bronze Thrust Washers.)

Crankshaft End Play (Measured At No. 5 Main Bearing)----- .004 to .012 Inch; Install New Thrust Washers if End Play Exceeds .020 Inch.

Oversize Thrust Washers for End Play Available for Service ----- .006 Inch

Connecting Rod Bearing Journal Diameter ----- 2.748 to 2.749 Inches

Main Bearing Journal Diameter ----- 2.998 to 2.999 Inches

Crankshaft Main and Connecting Rod Journal Bearing Out of Round ----- Maximum .001 Inch

Inside Diameter Of Main Bearing Liners (In Place and Capscrews Tight)----- 3.0006 to 3.0026 Inches

Clearance Between Main Bearing Liner and Journal ----- .0020 to .0046 Inch; Install New Bearing Liner when Clearance Exceeds .0065 Inches.

Width of 1st, 3rd, 5th and 7th Main Bearing Liners ----- 2-7/32 Inches

Width of 2nd, 4th and 6th Main Bearing Liners----- 1-5/32 Inches

Width Between Crankshaft Main Bearing Cheeks:

A. 3rd, 7th ----- 2.620 to 2.630 Inches

B. 2nd, 4th and 6th ----- 1.575 to 1.5675 Inches

**CC-6**

C.5th -----2.624 to 2.626 Inches

Width Between Crankshaft Rod Bearing Journal Cheeks ----- 1.9975 to 2.0025 Inches

Undersize Main Bearing Liners Available for Service ----- .002, .010, .020, .030 Inch

Crankshaft Main Bearing Journals should be ground to ----- 2.988-2.989 Inches for .010 Inch Undersize Bearing  
2.978-2.979 Inches for .020 Inch Undersize Bearing  
2.968-2.969 Inches for .030 Inch Undersize Bearing

Undersize Connecting Rod Bearing Shells Available for Service ----- .002, .010, .020, .030 Inch

Connecting Rod Crankshaft Journals should be ground to ----- 2.738-2.739 Inches for .010 Inch Undersize Bearing  
2.728-2.729 Inches for .020 Inch Undersize Bearing  
2.718-2.719 Inches for .030 Inch Undersize Bearing

**CAMSHAFT BUSHINGS**

Number of Bearing Surfaces on Camshaft ----- 5

Type Bushing ----- Replaceable, Precision, Steel Backed Babbitt

Bushing Lubrication ----- Pressure Lubricated from Oil Pump; Camshaft Drilled to Provide Pressure Lubrication to Valve Rocker Arm Assembly, and to Timing Gear Train.

Diameter of Camshaft at Each Bearing Surface ----- 2.246 to 2.247 Inches

Inside Diameter of Each Bushing (Measured when in Place in Block) ----- 2.2484 to 2.2514 Inches

No. 1 (Front) Bushing Length ----- 1-21/32 Inches

No. 2, 3 and 4 Bushings Lengths ----- 1-7/16 Inches

No. 5. Bushing Length ----- 1-5/32 Inches

Camshaft End Play ----- Automatically Taken up by Spring Loaded Thrust Button in Front End of Camshaft. Bronze Washer Provided Between Drive Gear and Front Bearing.

Camshaft Bronze Washer

Outside Diameter ----- 3.240 to 3.260 Inches

Inside Diameter ----- 2.250 to 2.260 Inches

Thickness ----- .1225 to .1275 Inch

**VALVE PUSH ROD LIFTERS**

Type ----- Mushroom Type

Outside Diameter of End that Projects into Block ----- .8097 to .8102 Inches

Diameter of Bore in Block for Lifter ----- .8115 to .8130 Inches

Oversize Lifter Available for Service ----- .010 Inch Oversize Lifter

Bore in Block Must be Reamed to ----- .8215 to .8225 Inch for .010 Inch Oversize Lifter.

**VALVES**

**Valve Tappet Clearance**

Intake ----- .015 Inch, Engine Cold  
Exhaust ----- .025 Inch, Engine Cold

**Exhaust Valves**

Angle of Valve Face ----- 44 Degrees

Maximum Valve Face Runout ----- .002 Inch as Determined with a Dial Indicator.

Diameter of Valve Stem ----- .400 to .401 Inch; Install New Valve if there is More Than .002 Inch Difference in Diameter at any Point on Stem.

Inside Diameter of Valve Guide ----- .4045 to .4055 Inch

Valve Stem Clearance in Guide ----- .0035 to .0055 Inch

Valve Rotators ----- Positive Type

**Exhaust Valve Seat Insert**

Seat Angle ----- 45 Degrees

Seat Width ----- .081 to .096

Insert Height ----- .250 to .255 Inch

Outside Diameter of Insert ----- 1.630 to 1.631 Inches

Inside Diameter of Insert ----- 1.370 to 1.380 Inches

Maximum Allowable Seat Runout ----- .002 Inch as Determined with a Dial Indicator.

**Intake Valves**

Angle of Valve Face ----- 44 Degrees

Maximum Valve Face Runout ----- .002 Inch as Determined With a Dial Indicator.

Diameter of Valve Stem ----- .402 to .403 Inch; Install New Valve if there is More Than .002 Inch Difference in Diameter at any Point on Stem.

Inside Diameter of Valve Guide --- .4045 to .4055 Inch (After Assembly)

Stem Clearance in Guide ----- .0015 to .0035 Inch

**Intake Valve Seat**

Seat Angle ----- 45 Degrees

Seat Width ----- .070 to .086 Inch

**Exhaust Valve Guides**

Length ----- 3-5/8 Inches

Outside Diameter ----- .7510 to .7515 Inch

Inside Diameter ----- .4045 to .4055 Inch

Valve Stem Clearance in Guide ----- .0035 to .0055 Inch

Distance Above Head Guide Must Protrude ----- 1-1/16 Inch Press Fit

**Intake Valve Guides**

Length ----- 3-5/8 Inches

Outside Diameter ----- .7510 to .7515 Inch

Inside Diameter ----- .4045 to .4055 Inch

Valve Stem Clearance in Guide ----- .0015 to .0035 Inch

Distance Above Head Guide Must Protrude ----- 1-1/16 Inch Press Fit

**VALVE SPRINGS**

Free Length ----- Approx. 2.438 Inches

Spring Pressure at Compressed Height of 1-17/32 Inches (Valve Open) ----- 95.5 Pounds; Install New Spring if Pressure is Less Than 86 Pounds.

Spring Pressure at Compressed Height of 1-15/16 Inches (Valve Closed) ----- 45 Pounds; Install New Spring if Pressure is Less Than 41 Pounds.

**ROCKER ARM ASSEMBLY**

Rocker Arm Bushings ----- Replaceable Precision Bronze Bushing

Number of Bushings ----- 12

Lubrication ----- Pressure Lubricated; Crankcase Oil to Rocker Arms Metered by Camshaft.

Oil Holes in Rocker Arm Shaft ----- Oil Holes Must Face Push Rod Side of Engine Only. Shaft Cannot Be Rotated.

Positioning of Exhaust Valve Rocker Arms ----- Spacer Washers Position Exhaust Valve Rocker Arm and Eliminates End Play Without Binding.

Outside Diameter of Rocker Arm Shaft ----- .872 to .873 Inch

Inside Diameter of Rocker Arm Bushing ----- .8745 to .8755 Inch

**OIL PUMP**

Type ----- Positive Displacement, Gear Type Pump  
Driven off Camshaft

Pressure Relief Valve ----- Maintains 40 to 45 Pounds Full Pressure  
(Oil Warm, Engine Operating at Full Governed  
Speed) Relief Valve is Adjustable.

**WATER PUMP AND THERMOSTAT**

Type of System ----- Pressurized Thermostat Controlled  
By-Pass Type; Forced Circulation(Pump).

Type Pump ----- Impeller Vane Type

Temperature Control ----- By-Pass Type Thermostat

**FUEL SYSTEM**

Type of System ----- Gravity Flow

Carburetor ----- Zenith Series 62

Float Level ----- 1-39/64 Inch from Machined Surface  
of Cover to Top Surface of the Float.

Load Jet ----- Adjustable

Venturi Size ----- 1.220 Inch Dia. Throat

Flange ----- SAE 1-1/2 Inch

**TIGHTENING TORQUE SPECIFICATIONS**

Engine	Torque in Ft. Lbs.	Size	Threads per In.	Type
Camshaft Nut -----	125	1-1/8	12	NF*
Connecting Rod Bearing Capscrews-----	95 to 105	1/2	20	NF
Crankshaft Pulley Bolt----	100	5/8	18	NF
Cylinder Head Cover (Valve Cover)Stud Nuts----	5 Max.	7/16	20	NF
Cylinder Head Stud Nuts---	120 to 125	9/16	18	NF
Cylinder Head Bolts (Grade 8)-----	145 to 150	9/16	18	NF
Engine to Flywheel Housing-Dust Cover and Capscrews-----	80	1/2	20	NF
	50	1/2	13	NC**
Flywheel to Crankshaft Capscrews-----	100	5/8	18	NF
		9/16	18	NF
Engine Mount-----	200	5/8	18	NF
	400	3/4(rubber mounted)	16	NF
	200	3/4(spring mounted)	16	NF
Generator Mounting Capscrews -----	15	5/16	18	NC
<b>Injectors, Diesel Fuel</b>				
Clamp Stud Nuts, Injector to Cylinder Head (Diesel)-----	14 to 17	3/8	24	NF
Injector Nozzle Cap Nut (Diesel)-----	50 to 55			
Powercl Clamp Screws (Diesel)-----	100	1-1/8	16	NC
Mainbearing Capscrews--	145 to 155	5/8	11	NC
<b>Manifolds</b>				
Manifold Clamp Stud Nuts-----	25	7/16	20	NF

Ft. Lbs. CC-7  
per In.

Exhaust Elbow Stud Nuts and Capscrews-----	25	1/2	13	NC
Water Manifold Hold Down Capscrews-----	15	5/16	18	NC
Oil Filter Mounting Capscrews -----	25	3/8	16	NC
Oil Pan Capscrews-----	10	3/8	16	NC
Rocker Arm Bracket Studs and Capscrews-----	40	7/16	14	NC
Water Pump and Fan Shaft Nut-----	60	5/8	18	NF
Water Pump Mounting Capscrews-----	25	3/8	16	NC

Loader Torque in Ft. Lbs. Size Threads per In. Type

Converter Housing to Flywheel Housing-----	30	3/8	16	NC
Transmission Mounting Brackets -----	100	5/8	11	NC
Transmission Bracket to Frame -----	200	3/4	16	NF
Steering Gear to Frame---	155	5/8	11	NC
Hydraulic Pump Mounting--	50	1/2	13	NC
Hydraulic Valve Mounting Capscrews-----	25	1/2	20	NF
Lift Cylinder Head Capscrews-----	140	5/8	18	NF
Lift Cylinder Piston Rod Nut -----	300	1-1/4	12	NF
Tilt Cylinder Head Capscrews -----	90	1/2	20	NF
Tilt Cylinder Piston Rod Nut -----	175	1	14	NF
Axle Mounting Bolts -----	400	3/4	16	NF
	625	7/8	14	NF
	950	1	14	NF
(W-9 Series B only)	550	1	14	NF
Wheel Mounting Nuts-----	250	3/4	16	NF







NOTE: The above Specifications are given in foot pounds dry torque.

\*NF - National Fine  
\*\*NC - National Coarse

## GENERAL TORQUE SPECIFICATION TABLE (Revised 5-64)

**USE THE FOLLOWING TORQUES WHEN SPECIAL TORQUES ARE NOT GIVEN**

**NOTE:** These values apply to fasteners as received from supplier, dry, or when lubricated with normal engine oil. They do not apply if special graphited or moly-disulphide greases or other extreme pressure lubricants are used. This applies to both UNF and UNC threads.

SAE Grade No.	5		8 *			
Bolt head identification marks as per grade Note: Manufacturing Marks Will Vary						
	Torque Foot Pounds			Torque Foot Pounds		
Bolt Size	Min.	Max.	Min.	Max.		
1/4"	9	11	12	15		
5/16	15	18	24	28		
3/8	35	40	45	50		
7/16	54	60	70	80		
1/2	80	90	110	125		
9/16	110	120	160	180		
5/8	150	165	220	240		
3/4	260	280	380	420		
7/8	360	400	600	660		
1"	540	600	900	1000		
1-1/8	720	800	1280	1440		
1-1/4	1000	1100	1800	2000		
1-3/8	1460	1680	2380	2720		
1-1/2	1940	2200	3160	3560		

\* Thick nuts must be used with Grade 8 bolts

### TIMING CHART

ENGINE	FULL LOAD GOVERNED ENGINE SPEED	NUMBER OF DEGREES
(W8B) A 401D (W9B) (W10B)	2000	33° BTDC
A 401D (W10)	1800	31° BTDC
A 451D (W12)	2000	31° BTDC
(W8B) A 377G (W9B) (W10B)	2000	4° BTDC (Static) 28° BTDC (Running at 2000 RPM)

### VALVE TIMING

With valve clearances set correctly, dial indicator mounted above valve stem, reading taken with valve .040" off its seat.

A401D Inlet Opening (No. 1 Cyl.) ----- 3° BTC  
 A377G Inlet Opening (No. 1 Cyl.) ----- 6° ATC

"Inlet opening" is the only position on these engines that can be checked by the crankshaft pulley marks. Since the crankshaft pulley is only marked to 5° ATC, the 6° ATC mark will have to be measured and scribed on the pulley. Use the degree marks already on the pulley for measurement. If this position is correct, it can be assumed that the timing gears are correctly marked and properly assembled.

NOTE: The CASE CORPORATION reserves the right to make improvements in design or changes in specifications at any time without incurring any obligation to install them on units previously sold.

**SECTION**

**K**

**SERVICING THE**



**CYLINDER HEADS**



**VALVE SYSTEMS**



**ROCKER ARMS**



**DECOMPRESSOR**

**ON**

**CASE POWRCEL DIESEL ENGINES**

## TABLE OF CONTENTS

CYLINDER HEAD AND COMPONENTS - Disassembly and Installation . . . . .	K-2 thru K-5
DECOMPRESSOR (If So Equipped) - Disassembly and Assembly . . . . .	K-6
ROCKER ARMS AND SHAFTS - Disassembly, Inspection and Assembly . . . . .	K-8
CYLINDER HEAD AND VALVES - Disassembly and Assembly . . . . .	K-10
EXHAUST VALVE ROTATORS . . . . .	K-10
VALVES, GUIDES AND SPRINGS - Inspection . . . . .	K-12
INTAKE AND EXHAUST VALVES - Refacing . . . . .	K-14
INTAKE AND EXHAUST VALVE SEATS - Grinding . . . . .	K-15
LOCATING TOP DEAD CENTER AND TAPPET ADJUSTMENT . . . . .	K-16

## CYLINDER HEAD AND COMPONENTS

(Refer to Figure K-1)

### Removal

Steam clean the engine completely before doing any disassembly or service work.

Drain cooling system. Remove the intake, exhaust and water manifolds. Remove the rocker arm covers. Disconnect and remove the decompressor if so equipped, Page K-6.

Remove the rocker arm assemblies and tag them for proper installation. (Refer to Page K-8.

Disconnect the high pressure fuel lines to

the injectors and cap them. Disconnect the fuel leak-off tubes between each cylinder head and cap them.

Remove the push rods and tag or store them in a holder or rack so they can be installed in their same locations.

Remove the cylinder head bolts or nuts and lift the heads off the engine. Remove the head gaskets and discard them.

### Inspection and Installation

Remove all carbon and clean all parts before installation.

#### STANDARD HEAD GASKETS

If you are installing the standard gasket, install the new gasket with new rubber seals. The gasket must be installed with either the copper side up or the side with the case part number up. Continued on Page K-5.

#### FIRE RING HEAD GASKETS

If you are installing the fire ring head gasket, inset B, cylinder sleeve protrusion

must be checked to determine which fire ring to install. Only the standard fire ring is included in the valve grind gasket kit, however a thicker fire ring (.004") is available if the protrusion checks indicate a need for it. The thicker fire ring can be identified by a blue marking stripe.

Refer to Pages K-4 and K-5 for the procedure to follow when installing the fire ring cylinder head gasket.

# REMOVAL AND INSTALLATION OF CYLINDER HEAD AND COMPONENTS

**CAUTION**  
DO NOT OVER  
TIGHTEN COVER NUTS

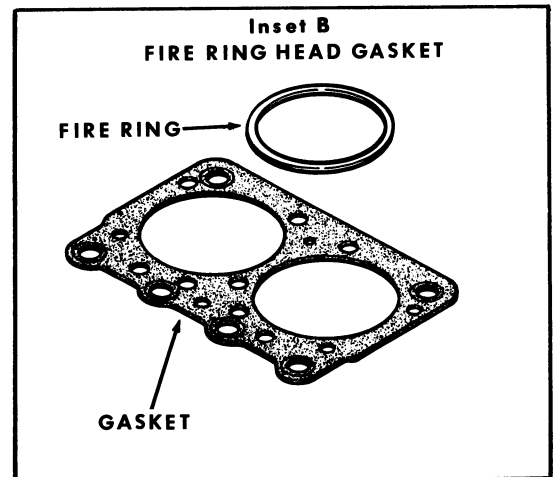
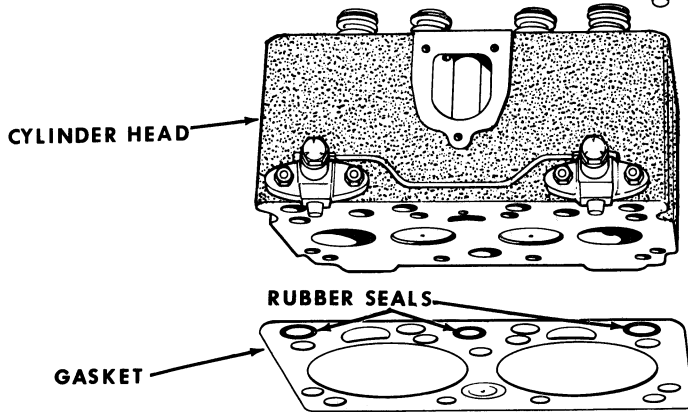
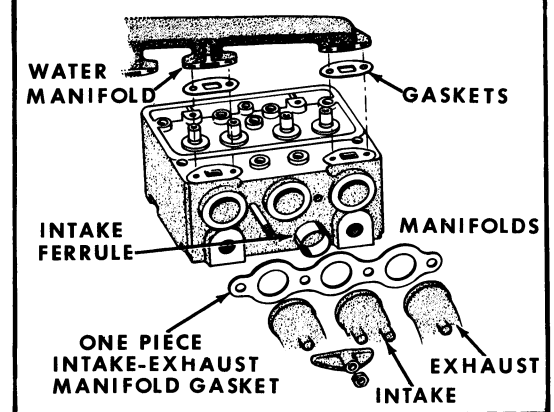
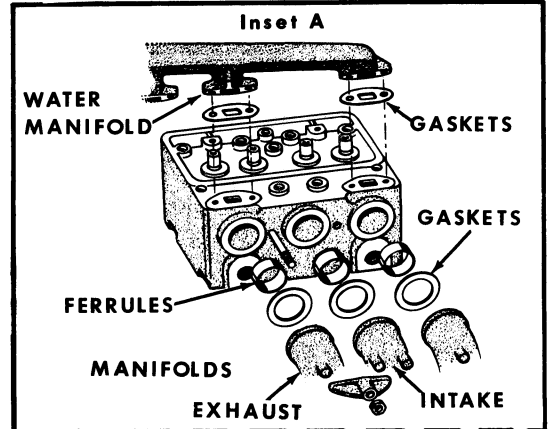
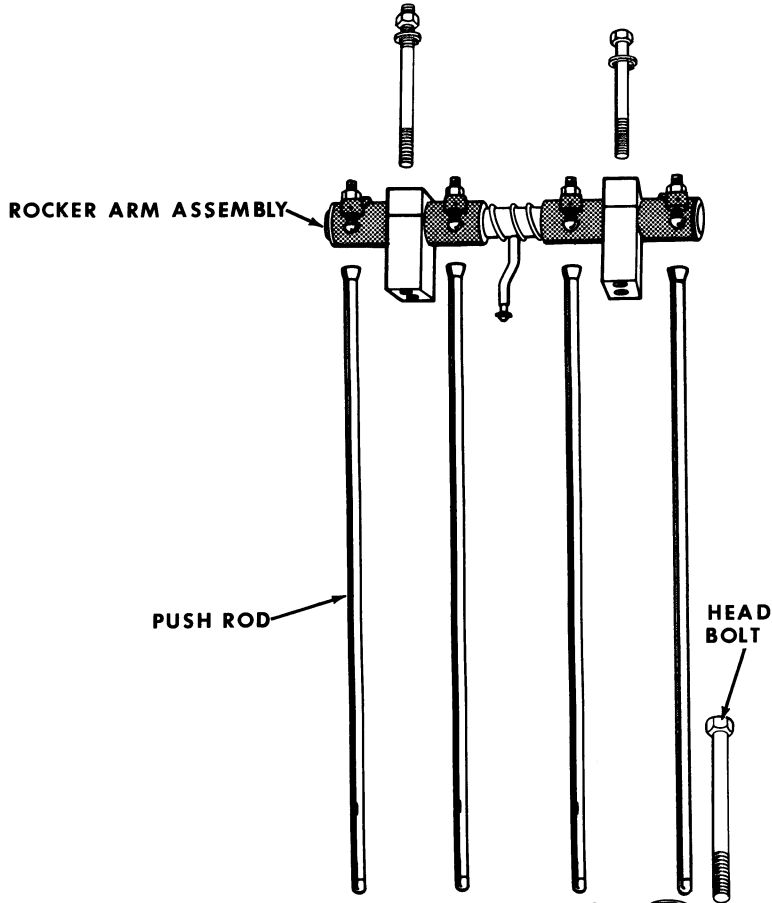
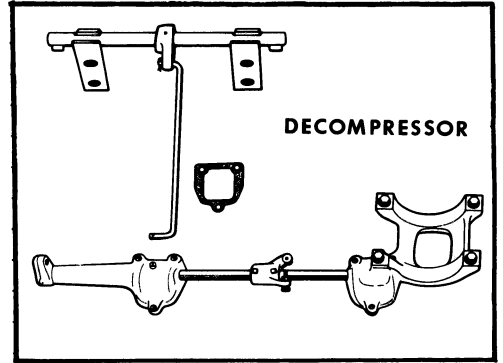
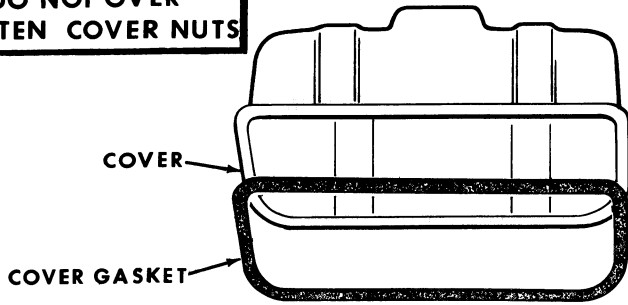

## Inspection and Installation Fire Ring Gaskets (Continued)

The following procedure must be followed when installing the fire ring head gasket:

1. Clean the top surface of the block and sleeve flange carefully. All traces of carbon and other deposits must be removed. During the final cleaning operation, the use of a rag dampened in solvent is recommended.
2. Using a small stone, remove any small burrs in the areas to be measured so that accurate readings can be obtained.

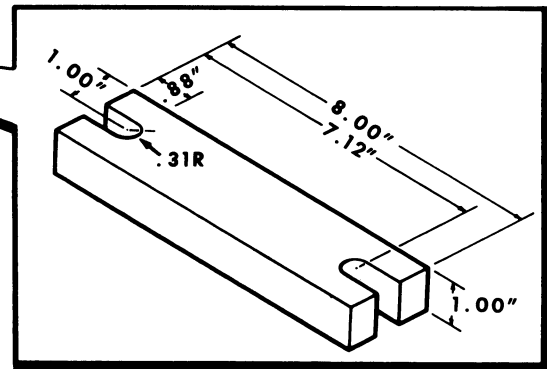
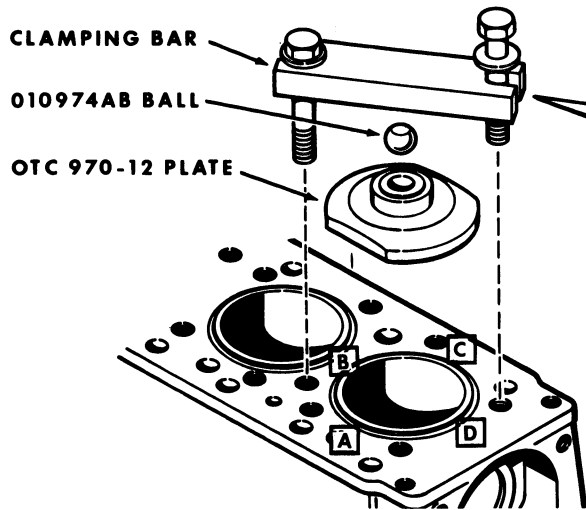

MEASURE SLEEVE PROTRUSION AT POINTS A, B, C, AND D.

Figure K-2

4. Either a magnetic base dial indicator or a depth micrometer can now be used to determine the cylinder sleeve protrusion as indicated in Figure K-3. Refer to chart, Figure K-5, to make sure the correct fire ring is used.

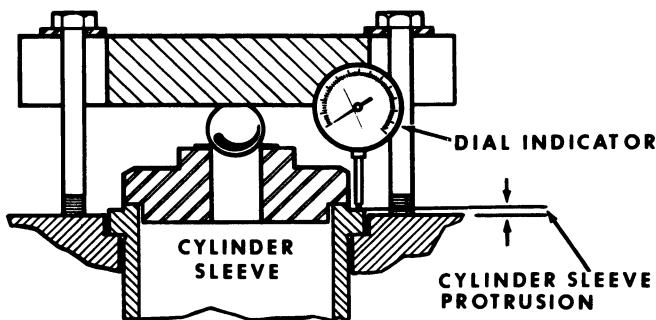

Figure K-3

5. Install cylinder head gaskets. **IMPORTANT**  
Two of the capscrew holes in the gasket are slightly smaller and act as guides to position the gasket as well as the fire ring,

3. Using plate OTC970-12\* from cylinder sleeve puller OTC970\*, 010974AB ball and clamping bar, clamp the cylinder sleeve in place, Figure K-2. Torque the hold down capscrews evenly to 50 foot pounds. **NOTE** Refer to Figure K-2 for clamping bar dimensions.

\*These tools are available through local Owatonna Tool Dealers or the Owatonna Tool Co., Owatonna, Minnesota.

Figure K-4. Regular line-up studs could be used for most engines. In some instances it is very difficult to install the

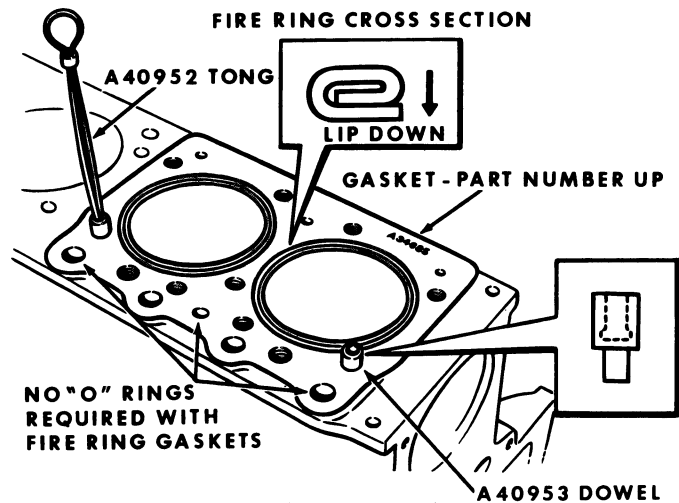

Figure K-4

rear cylinder head due to the limited space in which to place the head when lowering it down over the long guide studs.

## Inspection and Installation(Continued)

CYLINDER SLEEVE PROTRUSION	USE STANDARD FIRE RING	USE OVERSIZE (THICKNESS) FIRE RING
BOTH SLEEVES UNDER ONE HEAD FLUSH TO .002"		<b>X</b>
BOTH SLEEVES UNDER ONE HEAD .002" OR OVER BUT LESS THAN .0025" BETWEEN SLEEVES	<b>X</b>	
BOTH SLEEVES UNDER ONE HEAD OVER .0025" DIFFERENCE BETWEEN SLEEVES	ON THE HIGH SLEEVE	ON THE LOW SLEEVE

Figure K-5

6. For difficult installations, the use of dowel pins and a tong are recommended and can be purchased through a local Snap-On Tool Dealer or J.I. Case Central Parts Dept. under the following part numbers.

Snap-On Tool No.	Case Part No.
CF83-1 Tong	A40952
CF83-4 Dowel	A40953

7. Install the fire rings with the lip downwards, Figure K-4. **NOTE** Fire ring gaskets must be installed dry.

8. Carefully clean the cylinder heads as described in No. 1. If evidence of fretting or erosion exist in the area of the fire ring contact or if the head is warped more than .005", the head must be resurfaced.

9. Install cylinder heads and several bolts, then remove the A40953 dowels using A40952 tong and install all the bolts.

### STANDARD AND FIRE RING HEAD GASKETS

10. Install intake and exhaust manifold ferrules and new gaskets. **NOTE** When the manifolds are designed for the one piece manifold gasket, the ferrules are used only in the intake ports. Refer to Page K-3, inset A. Install the intake and exhaust manifolds and torque to proper torque. Refer to Specification Section.

11. Torque cylinder head bolts or nuts to the proper sequence illustrated in Figure K-6. The three torquing steps recommended are 50 foot pounds, 100 foot pounds and finally 150 foot pounds.

12. Install the push rods in their original location. Connect the high pressure fuel lines and leak-off tubes. Install the de-

compressor (if so equipped.) Refer to Page K-16 for proper firing order.

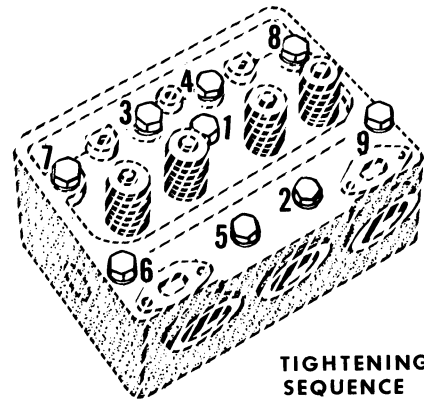

Figure K-6

13. Install the rocker arm assemblies in their original location.

14. Adjust the valve tappet clearance, refer to Page K-16.

15. Fill cooling system and start engine. Check that the rocker arms are receiving lubrication.

16. Run engine for approximately one (1) hour, under load if possible, to thoroughly warm up the engine and seat the head gaskets.

17. Stop the engine and retorque the cylinder head bolts or nuts to 150 foot pounds while the engine is still hot. Check and readjust the tappets.

18. Clean the rocker arm covers and remove the old gasket. Install new gaskets and seals; then install covers. Refer to Specification Section for proper torque. Do not over torque the valve cover nuts.

## **INSPECTION OF DECOMPRESSOR**

**(If So Equipped)**

**(Refer to Figure K-7)**

When the decompressor is engaged all the exhaust valves must be held in an open position. Inspect the trip pins for excessive wear. Inspect for bent or worn control linkage if the valves are not held open.

When the decompressor is disengaged and the tappet clearance is correct be sure the trip pins release the rocker arms completely. Inspect for loose coupling set screws, bent or worn control linkage, control link cotter pin missing or a pin in one of the control levers sheared off.

## **DISASSEMBLY OF DECOMPRESSOR**

**(Refer to Figure K-7)**

Remove the control link cotter pins (1) and link (2). Remove the decompressor control housings (3) and the housing gaskets (4). Loosen the coupling set screws (5) and remove the coupling (6).

Remove the roll pins (7) from the control

levers (8). Remove the control shafts (9) from the housings. Remove the control levers (8). Remove the trip pins (10) from the decompressor shaft (11). Remove and discard the "O" rings (12) from the shafts.

## **ASSEMBLY**

**(Refer to Figure K-7)**

Install the trip pins (10) and lever (8) with roll pin (7) to the decompressor mounting brackets (13). Install the new "O" rings (12) on the shafts - Install the shafts (9) into the housings (3) and install the control levers (8) with roll pins (7). Install the shaft coupl-

ing (6) and tighten square head set screws (5).

Install the housing and shaft assembly to the cylinder heads with new gaskets (4). Install the control link (2) with cotter pins (1).

## **DECOMPRESSOR ADJUSTMENTS**

**(Refer to Figure K-7)**

The stop bolts (14) in the coupling stop (6) should be adjusted so the decompressor can open the valves when engaged and lift the trip pins so they are clear of the rocker arms when disengaged (Refer to Inset A). Tighten the lock nuts (15) on the stop bolts (14) after adjustment is made.

# DISASSEMBLY AND ASSEMBLY OF DECOMPRESSOR

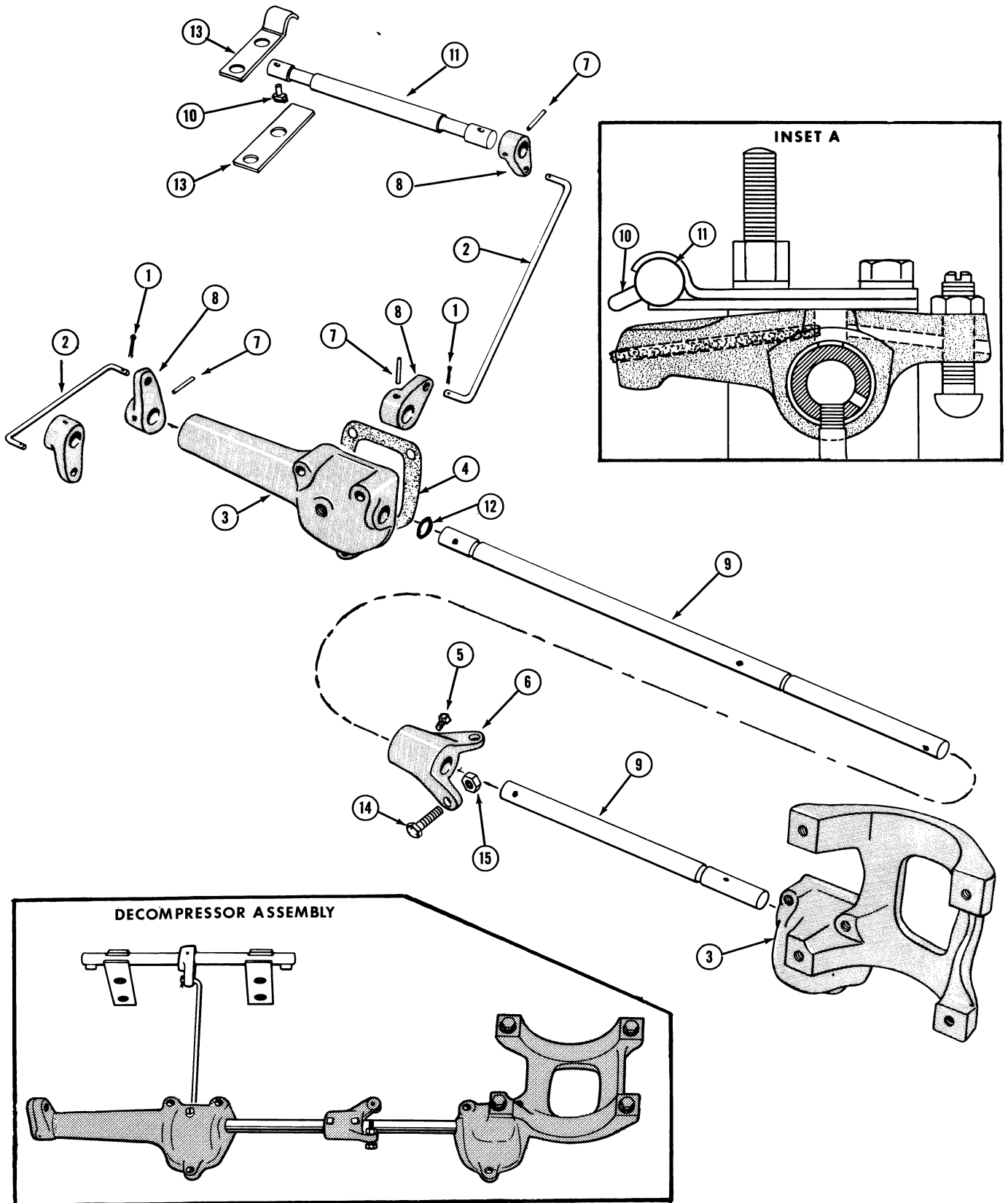

Figure K-7

## **DISASSEMBLY OF THE ROCKER ARMS (Refer to Figure K-8)**

Remove the rocker arm shaft bracket studs (15) and bolts (16). Remove and tag shaft assemblies for installation.

Unscrew the oil tube (1) and discard the "O" ring (2). Remove the snap rings (3), spacer washer (5) and keep count of the number of washers at each end of the shaft. Tag each rocker arm for original location. Remove the exhaust rocker arms (6) and the shaft brackets (7) from each end of the shaft.

Remove the intake rocker arms (8) and the shaft spring (9). Remove the plugs (10) by

using a rod and driving one plug clear thru the shaft. This will also clean out the dirt or sludge that has formed inside of the shaft.

Replacement shafts have these plugs installed at the factory. Remove the push rods and store them in a rack or holder so they can be installed in their original location.

Remove the oil wick (11) from each exhaust rocker arm and discard. Remove the bushing (12) from the cast rocker arm if it is worn using an Arbor (See Inset A).

## **INSPECTION (Refer to Figure K-8)**

Inspect the shaft spring for proper tension and broken coils. Refer to "Specification" Section. Inspect the rocker arm shaft for excessive worn spots on the bottom side of the shaft. Replace shaft if worn condition exists.

Inspect the rocker arm bushings by installing each rocker arm on the shaft in its proper location. The rocker arm must be free on the shaft without any side "wobble" If any is noted replace the cast rocker arm

bushing or replace the stamped rocker arm. Note the stamped rocker arm bushing is not replaceable. Replacement rocker arms come complete with bushings. Inspect the valve contact area on the rocker arm for wear. Replace if worn. Inspect the tappet adjusting screw for wear marks or pitting. Inspect the push rods for straightness, cracked or worn ends.

## **ASSEMBLY (Refer to Figure K-8)**

Clean all parts thoroughly. Place new bushing on Arbor and press into the cast rocker arm so the bushing (12) is evenly centered in the rocker arm and the oil hole is lined up with the oil hole in the rocker arm, (See Inset A). Check the bushing for high or rough spots and if they exist, they should be honed out. Install new oil wick (11) in the exhaust rocker arm. Lubricate each part with engine oil as they are installed.

Install a shaft spring (9) and two intake rocker arms (8) on the shaft (4). When installing the cast rocker arms the adjusting screw and the shaft oil hole must be on the same side, (See Inset A).

When installing the stamped steel rocker arms the adjusting screw and the shaft oil hole must be on opposite sides (See inset B).

Install the shaft brackets (7) on the shaft with the split side toward the push rod side of the engine. Install the exhaust rocker arms

(6) on the shaft. Install the same number of spacer washers (5) that were removed.

Install the snap rings (3) at each end of the shaft. Check the rocker arms for free movement. Install the oil tube (1) with new "O" ring (2). Install the push rods in their original location if they were removed. Install the adjusting screws (13) and lock nuts (14) if they were removed.

Install the rocker arm and shaft assembly on the cylinder head. Make sure all the push rods are engaged with the adjusting screws. Install the bracket studs (15) and bolts (16). Refer to "Specification" Section for proper torque. Check that the oil tube is in the oil hole in the cylinder head. Check exhaust rocker arms for excessive end play. One or more spacer washers can be used between the rocker arm and snap ring to remove the excessive end play. Check and adjust the tappet clearance. (Refer to Page K-16.)



## **DISASSEMBLY OF THE CYLINDER HEAD AND VALVES (Refer to Figure K-9)**

Using a valve spring compressor (Refer to Inset A) compress the spring (1). Remove the valve retainer locks (2) and the spring retainers (3) or valve rotators (4). Remove the valve springs (1), valve stem oil seal (5) and the valve spring seat. Remove any carbon from the valve stems before they are moved from the head.

Remove the intake valves (7) and the exhaust valves (8) from the head and store them in a rack or holder. Remove the intake valve guide (9) exhaust valve guide (10)

down through head using an Arbor (See Inset B). Refer to "Specification" Section for dimension of valve guides. The exhaust valve seats (11) can be removed with a special seat removing tool (See Inset C).

**NOTE** Never attempt to remove a valve seat with a center punch, cold chisel or pry bar.

To remove the expansion plug (12) it must be drilled and then pryed out.

## **ASSEMBLY (Refer to Figure K-9)**

Clean head completely and check for cracks. Remove all carbon from the bore of the valve guides with a wire brush and blow out with compressed air.

Install new valve guides (9 and 10) using an Arbor (See Inset B) and press the guides into the head from the top of the head. The distance the guides must protrude above the head is given in the "Specification" Section.

To install new exhaust valve seats (11) clean the recess in the cylinder head. Place the valve seats in dry ice to shrink them for easy installation. Insert the valve seats in the head and drive them in place using suitable driver. Lubricate the valves (7 and 8)

with engine oil and install them in the original location.

Install the valve spring seats (6), valve springs (1) and intake valve stem oil seal (5). Install the exhaust valve rotators (4) and the intake valve spring retainers (3). Compress the valve springs so the valve retainer locks (2) can be installed.

Install new expansion plug (12). Refer to Page K-2 for reinstalling the cylinder head.

## **EXHAUST VALVE ROTATOR (Refer to Figure K-9)**

When re-installing the rocker arm assembly, check the operation of the exhaust valve rotators. To check the operation of the rotators, place a dab of white paint on the rotator - note its position; -- then start the engine and observe whether or not the rotator is turning. Replace any rotators that will not turn. Do not attempt repairs on rotators.

It is impossible to determine whether or not the rotator is turning without an identifying mark.

There is no set speed at which the rotators should turn; some rotators will turn faster than others. As long as the rotator is turning the valve, it is functioning properly.

### **NOTE**

An excessive accumulation of deposits on the exhaust valve face and stem is also an indication that the rotators may not be functioning properly.

### **IMPORTANT**

When installing valve rotators:

Reassemble the rotator with original valve as they tend to become matched parts when they wear in.

If it is necessary to install a new valve always install a new rotator and retaining lock.



**Suggest:**

**If the above button click is invalid.**

**Please download this document**

**first, and then click the above link**

**to download the complete manual.**

**Thank you so much for reading**

# DISASSEMBLY AND ASSEMBLY OF THE CYLINDER HEAD AND VALVES

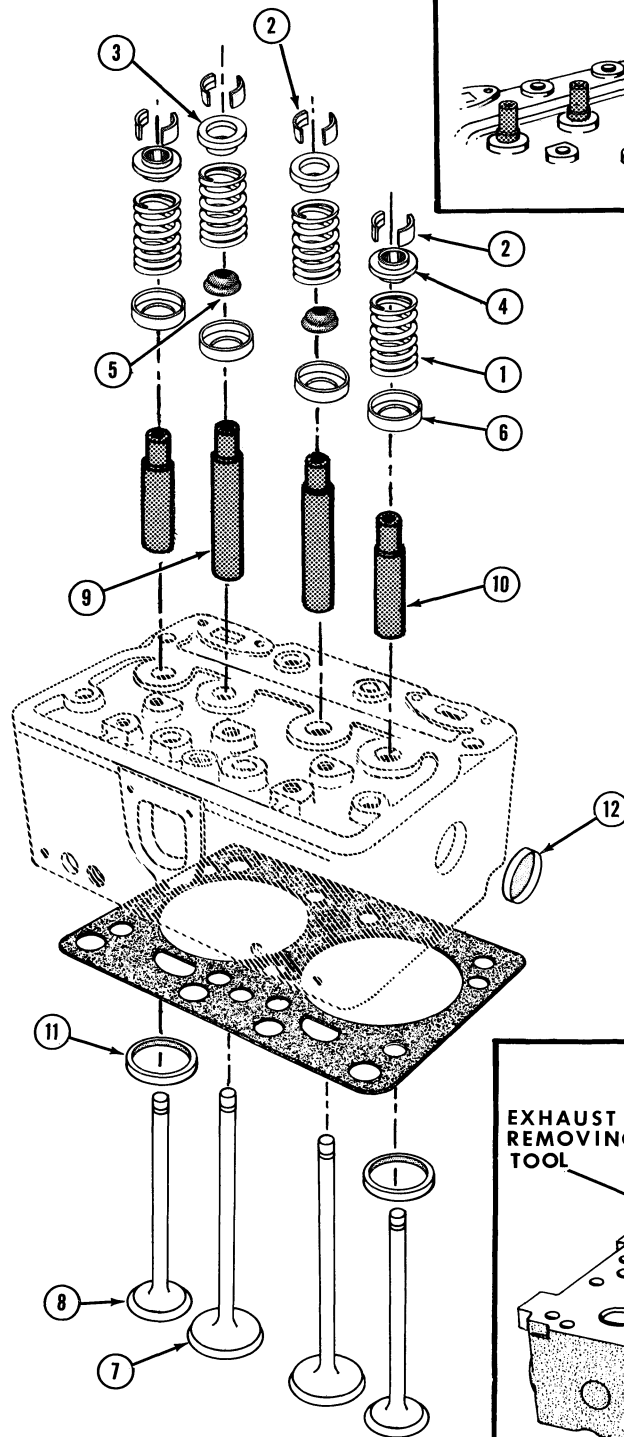
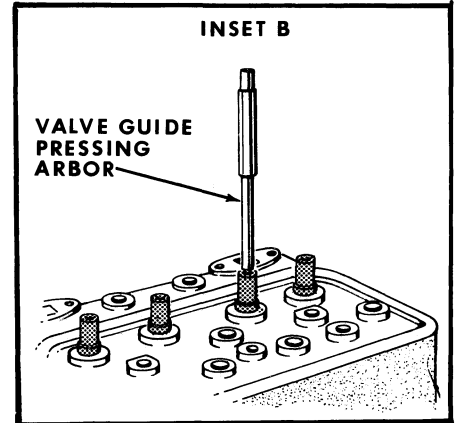
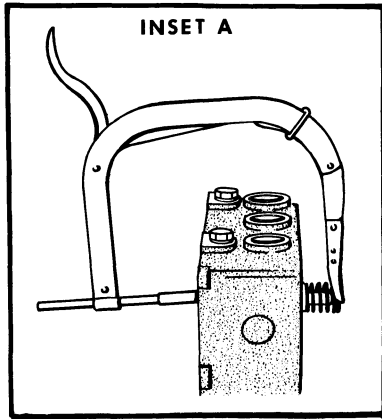
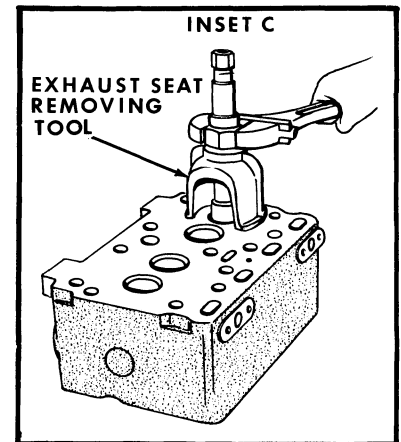
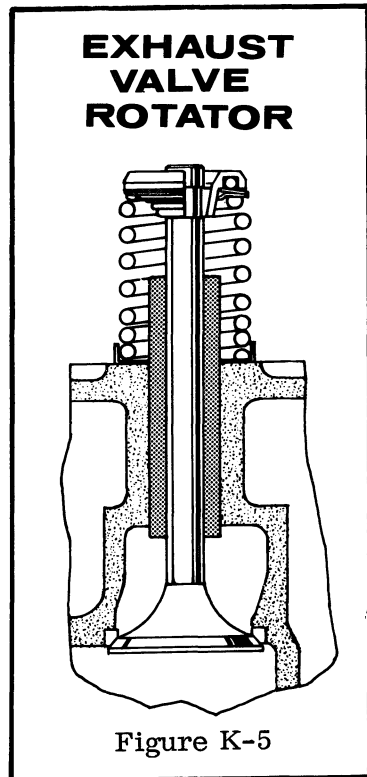

Figure K-9



**<https://www.ebooklibonline.com>**

Hello dear friend!

Thank you very much for reading.

Enter the link into your browser.

The full manual is available for immediate download.

**<https://www.ebooklibonline.com>**