

**W8,W9,W10  
Loaders**

**Service Manual**

9-99965R0

Reprinted



# TABLE OF CONTENTS

## W8, 9, 10 SERIES E LOADER

SERIES/SECTION	SECTION NO.	FORM NO.
10 SERIES - GENERAL INFORMATION		
General Engine Specifications .....	11	9-79541
Maintenance and Lubrication .....	IX	9-99965
20 SERIES - ENGINE		
Cylinder Head and Valves (Diesel Engines) .....	22	9-79391
Cylinder Head and Valves (Gasoline Engines) .....	22	9-79381
Engine Block Assemblies .....	23	9-79361
Water Pump, Pump Housing, Thermostats, Engine Oil Filter and Heat Exchanger .....	25	9-79421
Pierce Gear Driven Governor .....	26	9-79411
30 SERIES - FUEL SYSTEM		
Fuel System and Filter .....	31	9-79431
Robert Bosch Fuel Injection Pump .....	32	9-79452
Roosa Master Fuel Injectors .....	33	9-79463
62 Series Carburetor .....	35	9-79491
40 SERIES - HYDRAULICS		
Hydraulic System .....	VI	9-99965
Servicing the 25X Series Gear Type Hydraulic Pump .....	3B	9-74561
50 SERIES - STEERING		
Servicing the Combined Unit Power Steering Cylinder and Valve, Steering Linkage and Gear Box .....	Q	9-74563
Servicing the VTM Vane Type Power Steering Pump .....	PP	9-74561
60 SERIES - POWER TRAIN		
Servicing the Single-Reduction Differentials Universal Joints and Drive Shafts .....	T	9-74561
Supplement No. 1 Servicing the Single-Reduction Differentials .....	T	9-74561
Servicing the Planetaries and Axles .....	U	9-74561
Servicing the C-270 Series Torque Converter .....	X	9-74563
Servicing the 2000 Series Transmission .....	Y	9-74563
70 SERIES - BRAKES		
Servicing the Series 01 Hydraulic Brake Cylinder, Brake Shoes and Drums .....	W	9-74562
Supplement No. 2 Servicing the Transmission Cut-out Control Valve (Lever Operated) .....	W	9-74562
Servicing the Hydrovac Brake System .....	3W	9-74563
80 SERIES - ELECTRICAL SYSTEM		
Electrical System .....	11	9-99965
90 SERIES - MOUNTED EQUIPMENT		
Loader .....	VIII	9-99965

# Section 11

## GENERAL ENGINE SPECIFICATIONS W8E, W9E and W10E Loaders

THE MODEL AND ENGINE SERIAL NUMBER IS STAMPED ON A PLATE LOCATED ON THE SIDE OF THE ENGINE ABOVE THE CRANK-MOTOR.

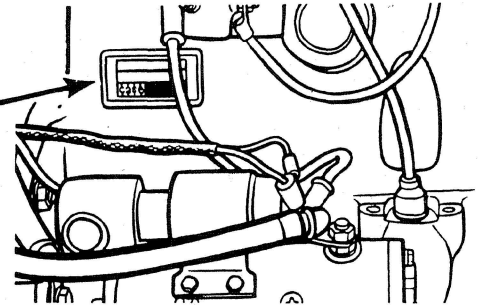

### DIESEL ENGINES

#### General

Type .....	6 Cylinder, 4 Stroke Cycle, Valve-in-Head.
Firing Order .....	1-5-3-6-2-4
Bore .....	4-1/8 Inches
Stroke .....	5 Inches
Piston Displacement .....	401 Cubic Inches
Compression Ratio .....	16.5 to 1
No Load Governed Speed .....	2150 RPM
Rated Engine Speed .....	2000 RPM
Engine Idling Speed .....	725 to 775 RPM
*Valve Tappet Clearance (Exhaust) .....	(Hot) .020 Inch .....(Cold) .025 Inch
(Intake) .....	(Hot and Cold) .015 Inch

\*Hot Settings Are Made After the Engine Has Operated At Thermostat Controlled Temperature For At Least Fifteen Minutes.

#### Piston and Connecting Rods

Rings per Piston .....	3
Number of Compression Rings .....	2
Number of Oil Rings .....	1
Type Pins .....	Full Floating Type
Type Bearing .....	Replaceable Precision, Steel Back, Copper-Lead Alloy Liners

#### Main Bearings

Number of Bearings .....	7
Type .....	Replaceable Precision Steel Back, Copper-Lead Alloy Liners

#### Engine Lubricating System

Oil Pressure .....	45 to 55 Pounds with Engine Warm and Operating at Rated Engine Speed
Type System .....	Pressure and Spray Circulation
Oil Pump .....	Gear Type
Oil Filter .....	Full Flow Spin on Type

#### Fuel System

Fuel Injection Pump .....	Robert Bosch, Type PES Multiple Plunger
Pump Timing .....	30 Degrees Before Top Dead Center (Port Closing)
Fuel Injectors .....	Pencil Type (Opening Pressure 2800 PSI)
Fuel Transfer Pump .....	Plunger Type, Integral Part of Injection Pump
Governor .....	Variable Speed, Fly-Weight Centrifugal Type, Integral Part of Injection Pump
1st Stage Fuel Filter .....	Full Flow Spin on Type
2nd Stage Fuel Filter .....	Full Flow Spin on Type

**<https://www.ebooklibonline.com>**

Hello dear friend!

Thank you very much for reading.

Enter the link into your browser.

The full manual is available for immediate download.

**<https://www.ebooklibonline.com>**

# GENERAL ENGINE SPECIFICATIONS W8E, W9E and W10E Loaders

## SPARK IGNITION ENGINES

### General

Type .....	6 Cylinder, 4 Stroke Cycle, Valve-in-Head
Firing Order .....	1-5-3-6-2-4
Bore .....	4 Inches
Stroke .....	5 Inches
Compression Ratio .....	7.5 to 1
Piston Displacement .....	377 Cubic Inches
No Load Governed Speed .....	2215 RPM
Rated Engine Speed .....	2000 RPM
Engine Idling Speed .....	725 to 775 RPM
*Valve Tappet Clearance (Intake) .....	(Hot and Cold) .015 Inches
(Hot) .015 Inches .....	(Cold) .025 Inches
Exhaust Valve Rotators .....	Positive Type
*Hot Settings Are Made After The Engine Has Operated At Thermostat Controlled Temperature For At Least Fifteen Minutes.	

### Piston and Connecting Rods

Rings per Piston .....	4
Number of Compression Rings .....	3
Number of Oil Rings .....	1
Type Pin .....	Full Floating Type
Type Bearings .....	Replaceable, Precision Steel Back, Copper Lead Alloy Liners.

### Main Bearings

Number of Bearings .....	7
Type Bearings .....	Replaceable, Precision Steel Back, Copper Lead Alloy Liners.

### Engine Lubricating System

Oil Pressure .....	45 to 55 Pounds with Engine Warm and Operating at Rated Engine Speed
Type System .....	Pressure Spray Circulation
Oil Pump .....	Gear Type
Oil Filter .....	Full Flow, Spin on Type

### Fuel System

Carburetor .....	Zenith w/solenoid shut-off
------------------	----------------------------

### Distributor Ignition

Contact Point Gap .....	.020 Inch
Dwell Angle .....	39°
Spark Plugs .....	Prestolite 18 8
Plug Gap .....	.025 Inch
Thread .....	18 MM
Shank Length .....	1/2 Inch

### Engine Timing

Static Timing .....	TDC
Running Timing .....	27° BTDC at Rated Engine Speed

**SECTION  
IX  
MAINTENANCE  
AND  
LUBRICATION**

## TABLE OF CONTENTS

SCHEDULED MAINTENANCE .....	3
Lubrication Points .....	4
LUBRICANTS .....	5
DIESEL FUEL .....	6
GASOLINE .....	7
APPROXIMATE CAPACITIES .....	7
AIR CLEANER SERVICE .....	8
Dry Air Cleaner .....	8
Oil Bath Air Cleaner .....	10
TRANSMISSION AND CONVERTER OIL AND FILTER CHANGE .....	11
SERVICING THE HYDRAULIC RESERVOIR .....	12
POWER STEERING SERVICE .....	14
BRAKE SYSTEM SERVICE .....	15

## MAINTENANCE/LUBRICATION

### Scheduled Maintenance

Component	Service	Comments
-----------	---------	----------

#### Every 10 Hours Or Daily

1. Loader Pivot Points Including Rear Axle Mounting Pivot Pins, Steering Cylinder and Linkage	Grease	Lithium "Soap-Base" Grease
2. Engine Oil	Check	
3. Rear Wheel Trunion Sockets	Grease	Lithium "Soap-Base" Grease
4. Oil Bath Air Cleaner	Check and service as required	Air cleaner must be serviced when dirt in oil cup is 1/2 inch deep.

#### Every 60 Hours Or Weekly

5. Drive Shaft Universal Joints NOTE: Slip joints, every 1000 hrs.	Grease	Lithium "Soap-Base" Grease
6. Hydraulic Oil	Check	
7. Differential Oil	Check	
8. Planetary Oil	Check	
9. Transmission Oil	Check	
10. Power Steering Oil	Check	
11. Hydrovac Breather	Clean	
12. Foot Throttle Cross Shaft	Lubricate	Engine Oil, A Few Drops

#### Every 120 Hours Of Operation

13. Engine Oil	Drain and Refill	With Filter, 13 quarts Without Filter, 12 quarts
14. Distributor	Grease	Lithium "Soap-Base" Grease

#### Every 240 Hours Of Operation

15. Steering Gear Box	Check	
16. Engine Oil Filter	Change	

#### Every 500 Hours Of Operation

17. Hydrovac Filter	Clean	
18. Hydrovac Cylinder	Lubricate	1 oz. Case TCH Oil

#### Every 1000 Hours Of Operation Or Yearly

19. Differential Oil	Drain and Refill	Refer to page 5.
20. Planetary Oil	Drain and Refill	Refer to page 5.
21. Transmission Oil	Drain and Refill	Case TCH Oil
22. Transmission Oil Filter	Replace	
23. Transmission Oil Strainer	Clean	
24. Transmission Breather	Clean	
25. Hydraulic Oil	Drain and Refill	Case TCH Oil
26. Hydraulic Oil Filter and Breather	Replace	
27. Power Steering Oil Filter	Replace	
28. Hydrovac Filter	Replace	

## Lubrication Points

The following points are to be lubricated once every 10 hours of operation or daily. In severe or abnormal working conditions lubrication should be more often. Clean grease fittings before applying grease gun.

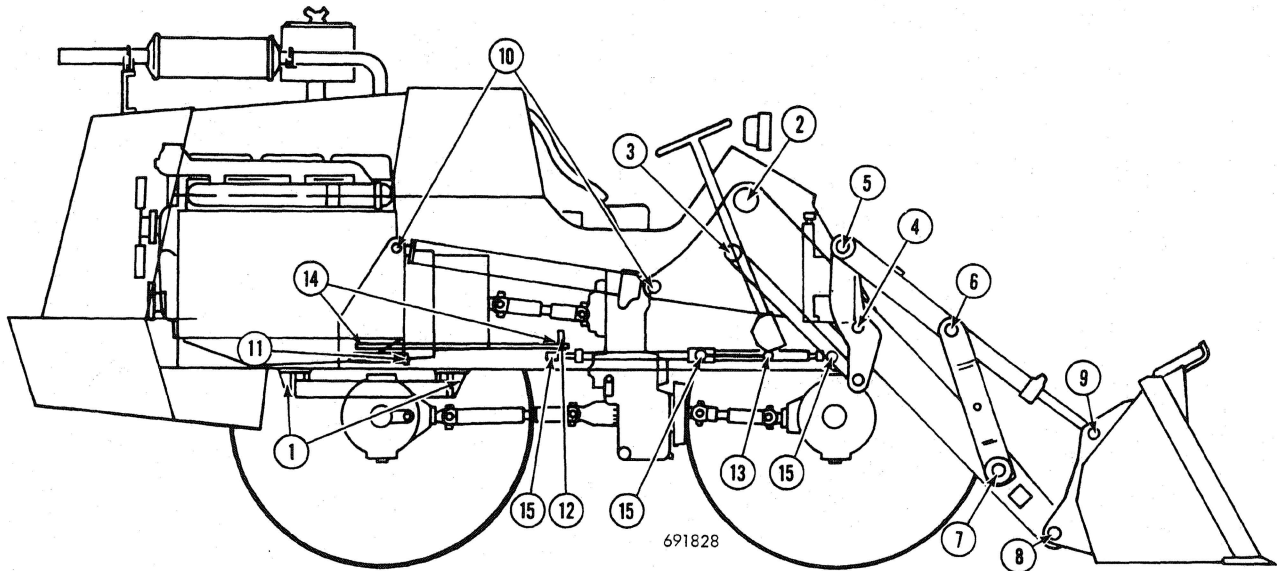

Figure 1

- |  |  |
|--|--|
| 1. Rear axle mounting pivot pins ..... | (2) Front and rear                           |
| 2. Lift arm pivot .....                | (2) One each side                            |
| 3. Leveling link .....                 | (4) Two each side                            |
| 4. Bellcrank .....                     | (2) One each side                            |
| 5. Bellcrank to tilt link .....        | (2) One each side                            |
| 6. Tilt cylinder pivot .....           | (4) Two each side                            |
| 7. Pivot link to lift arm .....        | (2) One each side                            |
| 8. Lift arm to bucket .....            | (2) One each side                            |
| 9. Tilt cylinder rod to bucket .....   | (2) One each side                            |
| 10. Lift cylinder .....                | (4) Two each side                            |
| 11. Tie rod ends .....                 | (2) One each side                            |
| 12. Intermediate steering lever .....  | (1) On pivot                                 |
| 13. Front drag link .....              | (1) Front ball stud                          |
| 14. Rear drag link .....               | (2) Front and rear ball studs                |
| 15. Steering cylinder .....            | (3) Front, rear and control valve ball studs |

## LUBRICANTS

### Engine Lubricating Oil

#### Diesel Engine

32° F. and above	SAE 30 (Service DS, Series 3, Mil-L-45199)
10° F. to 50° F.	SAE 20W (Service DS, Series 3, Mil-L-45199)
Below 32° F.	SAE 10W (Service DS, Series 3, Mil-L-45199)

#### Gas Engine

40° F. and above	SAE 30 (Service MS)
32° F. to 90° F.	SAE 20W (Service MS)
-10° F. to 60° F.	SAE 10W (Service MS)
Below -10° F. to 60° F.	SAE 5W-20 (Service MS)
All temp. above -10° F.	SAE 10W-30 (Service MS)

**NOTE:** If the Loader is operated during extremely cold weather, it may then be necessary to drain the oil while it is still hot and preheat it to approximately 100° F. before pouring it back into the crankcase just prior to starting.

### Transmission, Converter And Power Steering Oil

Use Case TCH Oil

#### Hydraulic System Oil

It is recommended that Case TCH Oil be used. An alternate oil may be used. It must be a heavy duty oil that meets American Petroleum Institute Service Designation MS or DG. For temperatures above 32° F. use SAE 10W. For temperatures below 32° F. use SAE 5W. If SAE 5W is not available, a Dexron type oil may be used.

#### Differentials And Planetaries

32° F. and above	SAE 90 Multipurpose Gear Lubricant, API-GL-4
Below 32° F.	SAE 80 Multipurpose Gear Lubricant, API-GL-4

The above lubricants are suitable for use in the steering gear housing.

#### Grease Fittings

##### RECOMMENDED LUBRICANTS

Below 32°	Multipurpose or No. 1 lithium soap-base grease
Above 32°	Multipurpose or No. 2 lithium soap-base grease

**FUEL**  
**Diesel Fuel**  
**Recommended Fuel**

Case diesel engines are designed to operate most efficiently with No. 2 diesel fuel. Most well known refiners and distributors market a good grade of diesel fuel and there should be no difficulty in obtaining it.

Do not confuse No. 2 diesel fuel with No. 2 furnace oil which is similar but does not always meet specifications for diesel engines.

**CAUTION:** No. 1 diesel fuel is not recommended for normal operating conditions. This is a lighter fuel which can result in loss of engine power, increased fuel consumption, and lessened injection pump life.

**Fuel Specifications**

There can be considerable variation in diesel fuels marketed as No. 2. The American Society for Testing Materials (ASTM) has established a widely recognized specification, ASTM Designation D975, which is used in the United States, Canada, and many other areas of the world. Any fuel purchased for use in a Case engine should meet this ASTM specification.

However, there is no world-wide standardization of diesel fuels and ASTM specifications are not used everywhere. Following are the most important specifications of an acceptable diesel fuel:

Pour point, maximum	10° F. below lowest atmospheric temperature at which engine must start and operate.
Cetane number, minimum	40 (45-55 for winter or high altitudes).
Sulphur, by weight, maximum	.50 of 1%
Water and sediment, by volume, maximum	.05 of 1%
Ash, by weight, maximum	.01 of 1%
Carbon residue on 10%, maximum	.20 of 1%
Distillation, 90% point	540° - 625°
End point	675°
Flash point, minimum	125° or legal
Viscosity, centistokes at 100° F.	2.0 - 4.3
Saybolt Universal Seconds at 100° F.	32 - 40
Corrosion, copper strip, 3 hours at 212° F.	No. 3 ASTM
API gravity, minimum	30

700312

## Gasoline

Case gasoline engines are designed to operate on REGULAR GRADE gasoline having a minimum Research Method rating of 90.7 Octane.

The average Octane ratings for regular grade gasoline are:

Motor Method .....	86.2 Octane
Research Method .....	94.2 Octane

These Octane ratings are used to define the anti-knock quality of gasoline. It has become common practice in the Petroleum Industry to refer to the Research Method rating.

When only one Octane rating is given and the rating method is not specified it can be assumed to be the Research Method rating.



**WARNING: NEVER FILL THE FUEL TANK WHEN THE ENGINE IS RUNNING OR WHEN NEAR AN OPEN FLAME. DO NOT SMOKE WHEN WORKING NEAR FLAMMABLE FUELS.**

### APPROXIMATE CAPACITIES

#### U. S. MEASURE

Fuel Tank .....	50 Gallons
Engine Crankcase	
Without Filter Change .....	12 Quarts
With Filter Change .....	13 Quarts
Differential Housing	
Front .....	22 Pints
Rear .....	29 Pints
Planetary Housing	
Front .....	3.5 Pints
Rear .....	5 Pints
Transmission and Torque Converter .....	25 Quarts
Cooling System .....	45 Quarts
Hydraulic System .....	14 Gallons
Power Steering System .....	3 Quarts
Steering Gear Housing .....	1 Pint
Air Cleaner Oil Cup	
Diesel .....	4.5 Pints
Gas .....	6 Pints

## AIR CLEANER SERVICE

### Dry Air Cleaner

The air cleaner must be serviced when the red band is in full view on the air cleaner service indicator.

**PRIMARY FILTER ELEMENT:** Washing is the preferred method of cleaning the element as it removes more dust and soot, thus restoring the element to an almost new condition.

Wash the filter in Case Filter Element Cleaner, Part No. A40910. Mix according to instructions on container. Do not use water pressure over 40 PSI at the nozzle. Let the element dry completely before installing. Do not use air pressure to dry the element.

The element can be cleaned with compressed air although it is not recommended because it will not remove carbon and soot. Do not use air pressure in excess of 100 PSI at the nozzle. Place the element on a clean flat surface, then place a cover (wood or metal) with a small opening over the top of the element. Place nozzle in opening in cover. Blow element clean, starting with low air pressure and gradually increasing it.

Inspect the element after it is clean and dry as shown in Figure 2.

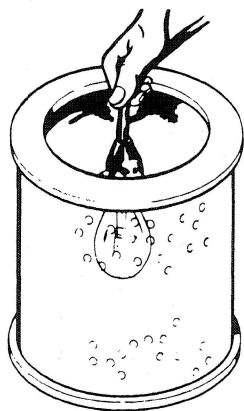

Figure 2

Rotate the filter around the light and check for damage and pin holes. Check the gasket for defects. Inspect the metal covering for dents. Any dent in the covering is a poten-

tial puncture, in that the paper element will rub the dent and a hole will result. Elements with holes or indications of fuzz must be replaced. Replace gasket if it is found to be defective. Do not accept a new filter or install a new or used filter if the metal covering is dented.

The filter should be replaced after it has been cleaned six times or once a year (1000 hours), whichever occurs first. When servicing the air cleaner, make sure all connections are air tight. Air cleaner efficiency is directly dependent upon air tight connections.

**SECONDARY FILTER ELEMENT:** Cleaning the secondary element is not recommended except in an emergency. If the element is cleaned it should be replaced as soon as possible. Check the secondary element for re-

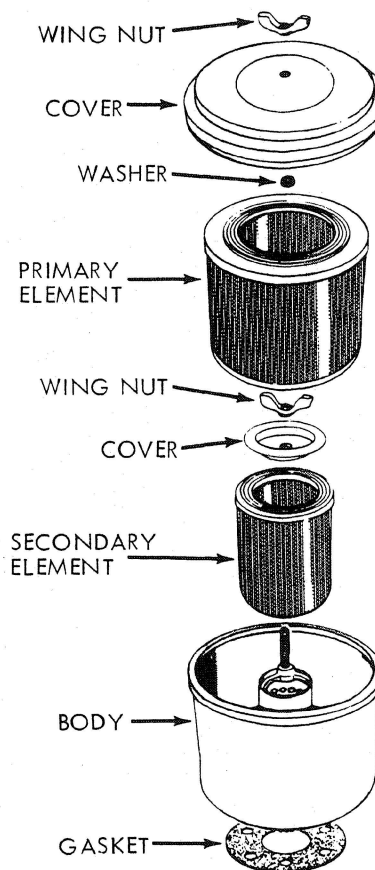

Figure 3

placement as follows: Install cleaned or new primary filter element and start engine. Observe air cleaner service indicator. If the

red signal is still in full view on the service indicator the secondary filter element must be replaced immediately.

# Oil Bath Air Cleaner

## Specifications

Oil capacity (Approximate) . . . . . Gas, 6 Pints, Diesel, 4.5 Pints  
 Oil used . . . . . Same as used in engine.  
 Service interval . . . . . Daily or when 1/2" dirt has collected (See "Servicing" below).

## Servicing

### INTERVAL

Service interval for this air cleaner depends on operating conditions. Remove and inspect oil cups daily. Clean the cups and element and change the oil whenever the dirt level reaches 1/2" in the bottom of either cup. Experience will dictate how often this occurs.

**NOTE:** Over-servicing does not utilize the oil bath feature to the fullest.

### OIL CUP SERVICING

1. Detach the oil cup retaining clamp/s and remove oil cup from air cleaner body.

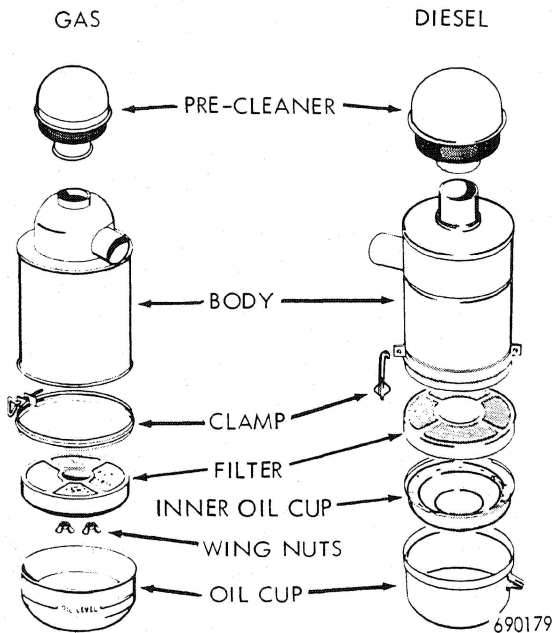

Figure 4

2. Remove filter screen from oil cup (diesel only). On gas engines, remove filter screen retaining wing nuts and remove filter from air cleaner body.

3. Pour out the oil, remove inner cup (diesel only), remove sludge and wipe clean.

4. Place inner cup in oil cup (diesel only). Refill oil cup to indicated level with engine oil specified on page 5.

**NOTE:** Do not overfill or underfill.

### ELEMENT ASSEMBLY SERVICING

1. Hold up the element to a strong light. An even, bright pattern of light through the element means it is clean.
2. If the element is even partially plugged with dirt, lint, or chaff, wash thoroughly with solvent. Then blow out with compressed air.
3. Place filter screen in oil cup (diesel only). On gas engines, position filter screen in air cleaner body and secure with wing nuts.
4. Position oil cup on air cleaner body and tighten oil cup retaining clamp/s.

### BODY ASSEMBLY SERVICING

1. The lower portion of the body assembly should be inspected each time the air cleaner is serviced. If there are any signs of dirt, clean as described below.
2. At least once a year, remove the body assembly and service as follows:
  - a. Remove oil cups and element assembly.
  - b. Check and clean the center tube.
  - c. Pump solvent through the air outlet with sufficient force and volume to produce a hard, even stream out the body assembly. Reverse flush until all foreign material is removed.

## TRANSMISSION AND CONVERTER OIL AND FILTER CHANGE

The transmission must be serviced after every 1000 hours of operation or yearly. This service consists of changing the transmission oil and oil filter and cleaning the oil strainer.

1. Remove the drain plug and oil strainer and gasket. Discard gasket.
2. Clean the oil strainer in cleaning solvent.

**NOTE:** Do not reinstall drain plug or strainer until the oil filter has been serviced. This procedure is recommended to allow maximum oil drainage.

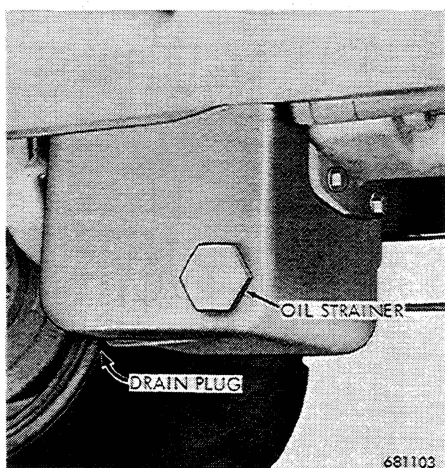

Figure 5

3. Loosen the filter cover retaining clamp

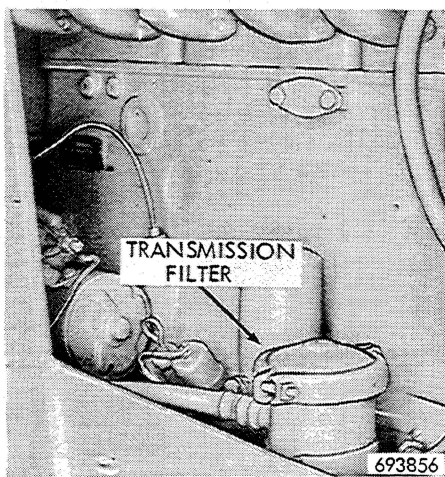

Figure 6

and remove clamp, filter cover with relief valve, gasket and filter element. Discard the gasket and filter element.

4. Remove the remaining oil from the filter case with a hand suction gun. Clean the inside of the filter case with a lint free cloth.
5. Place a new filter in the filter case. Position a new seal on the relief valve and a new gasket on the filter cover.
6. Position filter cover and clamp on filter case and tighten clamp bolts.
7. Fill the transmission with 5 gallons of Case TCH oil. Start the engine and run at low idle and slowly shift the transmission through all ranges. With the engine running and the transmission in neutral, oil should run out of the low level valve. Add oil as necessary to obtain the low oil level.
8. Run the engine at 1000 RPM with the transmission in neutral until the oil has reached operating temperature (180° - 200°). With the engine running at low idle and the transmission in neutral, oil should run out the full level valve. Add oil as necessary to obtain the proper level. Check for oil leaks.

**CAUTION:** The oil level must not be lower than the low level valve nor above the full level valve.

## SERVICING THE HYDRAULIC RESERVOIR

The hydraulic reservoir and its component parts must be serviced after every 1000 hours of operation.

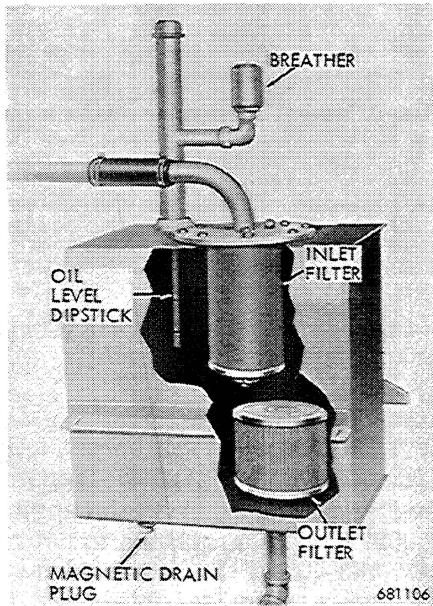

Figure 7

### Pressure/Vacuum Relief Valve (Breather)

In addition to replacing the filter at 1000 hour intervals the breather should be completely disassembled and cleaned to assure proper poppet operation.

#### Disassembly

1. Unscrew relief valve from fill tube.
2. Remove the two screws, end cap, cover, filter and flat washer from the valve body.
3. Push the sleeve and poppet assembly out of the valve body.
4. Remove the spring seat and O-ring from the sleeve.
5. Remove the snap ring from the bottom of the sleeve and push the poppet guide and poppet out of the sleeve. It may be necessary to remove the remaining snap ring in order to remove the poppet. Then remove the O-ring from the poppet.

6. Discard the O-rings and clean the valve parts and filter in mineral spirits. Dry with compressed air.

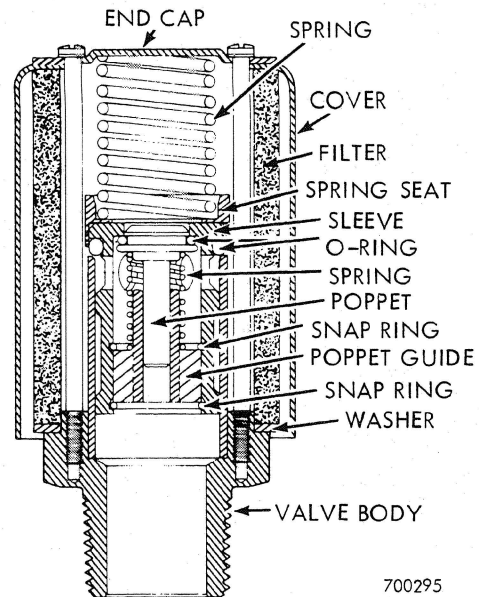

Figure 8

#### Assembly

1. Position a new O-ring on the poppet. Then place the poppet and poppet spring in the sleeve.
2. Install the upper snap ring if it was removed. Then position the poppet guide in the sleeve and install the lower snap ring in the sleeve.
3. Install a new O-ring on the sleeve. Then position the spring seat on the sleeve and install the sleeve and poppet assembly in the valve body sleeve.
4. Position the flat washer and filter on the valve body. Then place the cover over the filter.
5. Position the sleeve spring in the spring seat. Place the end cap on the spring and compress spring and install the two retaining screws with lockwashers.
6. Install relief valve on fill tube.

## Filters

1. Remove the reservoir drain plug and filler cap.

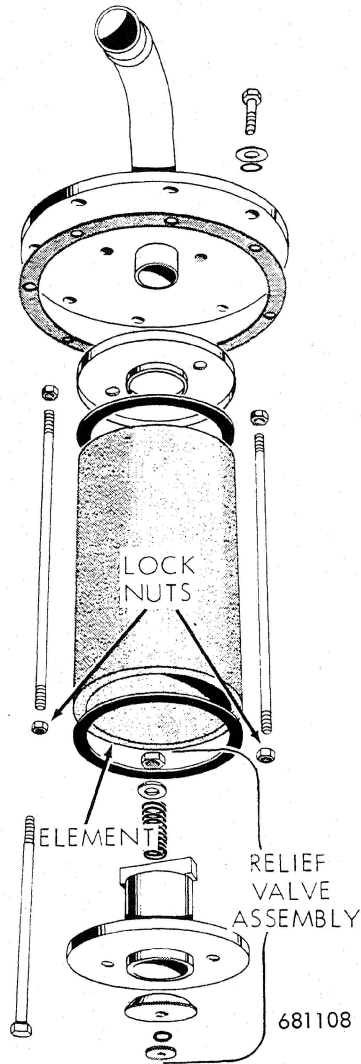

Figure 9

2. Disconnect the hose at the reservoir inlet elbow.

3. Remove the 8 bolts with flat washers and O-rings that secure the filter cover.
4. Remove the cover and inlet filter assembly from the reservoir. Then remove the inlet filter from the cover and discard the element. Refer to Figure 9.
5. Remove the outlet filter from the reservoir.
6. Clean the outlet filter in mineral spirits and dry with compressed air. Inspect the filter for holes and other defects which would reduce its filtering capabilities. Replace the filter if defects are found.

## Installation

1. Install the clean or a new outlet filter in the reservoir.
2. Position the inlet filter and its related parts on the filter cover. Torque the lock nuts to 30-35 inch pounds.
3. Position a new filter cover gasket and the filter cover assembly on the reservoir. Place a flat washer and new O-ring on the filter cover retaining bolts. Then install and tighten the bolts evenly.
4. Connect the hose to the inlet elbow and install the drain plug.
5. Refill reservoir with 8 gallons of Case TCH Oil. Start engine and operate the bucket through several complete cycles to properly charge the hydraulic system. Stop engine and check reservoir oil level and add oil as necessary.

## **POWER STEERING SERVICE**

The power steering system requires minor maintenance to assure a long service life. Normal servicing requires that only the power steering reservoir filter be replaced after every 1000 hours of operation. The power steering fluid need not be changed unless the fluid becomes contaminated. The fluid can be contaminated due to power steering pump failure, the entry of dirt and foreign matter into the reservoir while checking or adding fluid or internal steering cylinder failure. Using care when servicing the reservoir will prevent dirt from contaminating the fluid.

If the steering system is completely drained it will be necessary to bleed the air from the system. To bleed the system proceed as follows:

1. Fill the reservoir to the full mark on the dipstick. Use Case TCH Oil.
2. Start engine and run at low idle. **DO NOT** exceed low idle as the power steering pump could be damaged.
3. Turn the steering wheel one half turn to the right and left. Stop the engine and add fluid until the proper level is obtained.
4. Start the engine and turn the steering wheel through several complete turns. Stop the engine and check fluid level. Add fluid as required to obtain the proper fluid level.



**Suggest:**

**If the above button click is invalid.**

**Please download this document**

**first, and then click the above link**

**to download the complete manual.**

**Thank you so much for reading**

## BRAKE SYSTEM SERVICE

The brake system requires only minor preventive maintenance to assure a long service life. The areas of maintenance are the vacuum line filter, hydrovac cylinder breather and the hydrovac cylinder.

### Breather

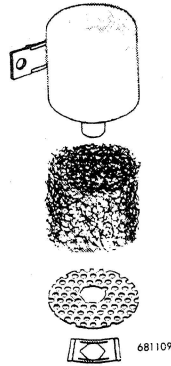

Figure 10

The breather should be cleaned after every 60 hours of operation and changed after every 1000 hours of operation or yearly.

Remove the breather from the loader and disassemble the breather by removing the filter retaining screen retainer, screen and filter. Clean the parts in cleaning solvent. Soak the filter in clean engine oil and let the excess oil drain off. Reassemble the breather and reinstall on the loader.

### Filter

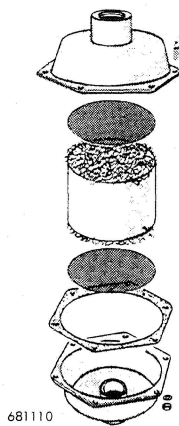

Figure 11

The filter should be cleaned after every 500 hours of operation and changed after every 1000 hours of operation or yearly.

Remove the filter from the vacuum line and disassemble by removing the six screws, lockwashers and nuts. Separate the filter halves and remove the filter, screens and gasket. Discard the gasket. Clean the parts in cleaning solvent. Soak the filter in clean engine oil and let the excess drain off. Reassemble the filter and install in the vacuum line.

### Hydrovac Cylinders

The hydrovac cylinder requires lubrication after every 500 hours of operation. To lubricate the cylinder, remove the pipe plug from the cylinder housing, Figure 12, and pour one (1) ounce of Case TCH oil into the cylinder and reinstall the pipe plug.

**NOTE:** The engine must not be running when servicing the hydrovac cylinder.

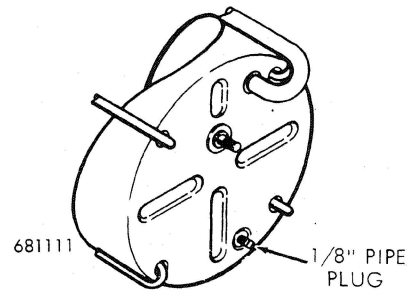

Figure 12

**<https://www.ebooklibonline.com>**

Hello dear friend!

Thank you very much for reading.

Enter the link into your browser.

The full manual is available for immediate download.

**<https://www.ebooklibonline.com>**