

SR210 / SR240 / SV280
Tier 4B (final)

Alpha Series Skid Steer Loader

PIN NGM418237 and above; PIN NHM435463 and above

TR270 / TR310 / TV370
Tier 4B (final)

Alpha Series Compact Track Loader

PIN NGM418237 and above; PIN NHM435463 and above

SERVICE MANUAL

Part number 48068130

1st edition English

January 2018



Contents

INTRODUCTION

Engine.....	10
[10.001] Engine and crankcase	10.1
[10.216] Fuel tanks	10.2
[10.400] Engine cooling system	10.3
[10.414] Fan and drive	10.4
[10.304] Engine lubrication system.....	10.5
Power coupling.....	19
[19.121] Pump-drive assembly	19.1
Front axle system	25
[25.450] Chain drive system.....	25.1
Rear axle system.....	27
[27.650] Chain drive system.....	27.1
Hydrostatic drive.....	29
[29.200] Mechanical control	29.1
[29.218] Pump and motor components.....	29.2
[29.202] Hydrostatic transmission	29.3
Brakes and controls	33
[33.110] Parking brake or parking lock	33.1
Hydraulic systems.....	35
[35.000] Hydraulic systems.....	35.1
[35.300] Reservoir, cooler, and filters.....	35.2
[35.104] Fixed displacement pump.....	35.3
[35.359] Main control valve.....	35.4
[35.525] Auxiliary hydraulic valves and lines	35.5
[35.600] High flow hydraulics.....	35.6

[35.724] Front loader hydraulic system control	35.7
[35.701] Front loader arm hydraulic system	35.8
[35.723] Front loader bucket hydraulic system	35.9
[35.734] Tool quick coupler hydraulic system	35.10
Frames and ballasting	39
[39.140] Ballasts and supports	39.1
Wheels	44
[44.511] Front wheels	44.1
[44.520] Rear wheels	44.2
Tracks and track suspension	48
[48.130] Track frame and driving wheels	48.1
[48.100] Tracks	48.2
[48.134] Track tension units	48.3
[48.138] Track rollers	48.4
Cab climate control	50
[50.100] Heating	50.1
[50.200] Air conditioning	50.2
Electrical systems	55
[55.000] Electrical system	55.1
[55.010] Fuel injection system	55.2
[55.011] Fuel tank system	55.3
[55.012] Engine cooling system	55.4
[55.019] Hydrostatic drive control system	55.5
[55.036] Hydraulic system control	55.6
[55.050] Heating, Ventilation, and Air-Conditioning (HVAC) control system	55.7
[55.051] Cab Heating, Ventilation, and Air-Conditioning (HVAC) controls	55.8
[55.100] Harnesses and connectors	55.9
[55.201] Engine starting system	55.10

<https://www.ebooklibonline.com>

Hello dear friend!

Thank you very much for reading.

Enter the link into your browser.

The full manual is available for immediate download.

<https://www.ebooklibonline.com>

[55.202] Cold start aid	55.11
[55.301] Alternator.....	55.12
[55.302] Battery.....	55.13
[55.404] External lighting	55.14
[55.408] Warning indicators, alarms, and instruments	55.15
[55.512] Cab controls.....	55.16
[55.518] Wiper and washer system.....	55.17
[55.525] Cab engine controls.....	55.18
[55.640] Electronic modules	55.19
[55.991] Telematics	55.20
[55.DTC] FAULT CODES.....	55.21
Front loader and bucket.....	82
[82.100] Arm.....	82.1
[82.300] Bucket.....	82.2
Platform, cab, bodywork, and decals.....	90
[90.150] Cab.....	90.1
[90.160] Cab interior trim and panels.....	90.2
[90.154] Cab doors and hatches	90.3
[90.102] Engine shields, hood latches, and trims	90.4
[90.120] Mechanically-adjusted operator seat.....	90.5
[90.124] Pneumatically-adjusted operator seat.....	90.6



INTRODUCTION

Contents

INTRODUCTION

Foreword - Important notice regarding equipment servicing	3
Safety rules - Ecology and the environment	4
Safety rules	5
Safety rules	6
Safety rules - Personal safety	7
Basic instructions - Loader arm lock and cab tilt procedure - radial lift machines (*)	8
Basic instructions - Loader arm lock and cab tilt procedure - vertical lift machines (*)	12
Torque - Standard torque data for hydraulics	16
Basic instructions - Shop and assembly	18
Torque - Minimum tightening torques for normal assembly	20
Basic instructions - Video links	25
General specification - Biodiesel fuels	26
Fluids and lubricants	29
General specification - Recommended engine oil for operating temperature ranges	30
General specification - Hydraulic oil for all models	31
Product identification	32
Product identification - Machine orientation	34

(*) See content for specific models

Foreword - Important notice regarding equipment servicing

All repair and maintenance work listed in this manual must be carried out only by qualified dealership personnel, strictly complying with the instructions given, and using, whenever possible, the special tools.

Anyone who performs repair and maintenance operations without complying with the procedures provided herein shall be responsible for any subsequent damages.

The manufacturer and all the organizations of its distribution chain, including - without limitation - national, regional, or local dealers, reject any responsibility for damages caused by parts and/or components not approved by the manufacturer, including those used for the servicing or repair of the product manufactured or marketed by the manufacturer. In any case, no warranty is given or attributed on the product manufactured or marketed by the manufacturer in case of damages caused by parts and/or components not approved by the manufacturer.

The manufacturer reserves the right to make improvements in design and changes in specifications at any time without notice and without incurring any obligation to install them on units previously sold. Specifications, descriptions, and illustrative material herein are as accurate as known at time of publication but are subject to change without notice.

In case of questions, refer to your CASE CONSTRUCTION Sales and Service Networks.

Safety rules - Ecology and the environment

Soil, air, and water quality is important for all industries and life in general. When legislation does not yet rule the treatment of some of the substances that advanced technology requires, sound judgment should govern the use and disposal of products of a chemical and petrochemical nature.

Familiarize yourself with the relative legislation applicable to your country, and make sure that you understand this legislation. Where no legislation exists, obtain information from suppliers of oils, filters, batteries, fuels, anti-freeze, cleaning agents, etc., with regard to the effect of these substances on man and nature and how to safely store, use, and dispose of these substances.

Helpful hints

- Avoid the use of cans or other inappropriate pressurized fuel delivery systems to fill tanks. Such delivery systems may cause considerable spillage.
- In general, avoid skin contact with all fuels, oils, acids, solvents, etc. Most of these products contain substances that may be harmful to your health.
- Modern oils contain additives. Do not burn contaminated fuels and or waste oils in ordinary heating systems.
- Avoid spillage when you drain fluids such as used engine coolant mixtures, engine oil, hydraulic fluid, brake fluid, etc. Do not mix drained brake fluids or fuels with lubricants. Store all drained fluids safely until you can dispose of the fluids in a proper way that complies with all local legislation and available resources.
- Do not allow coolant mixtures to get into the soil. Collect and dispose of coolant mixtures properly.
- The air-conditioning system contains gases that should not be released into the atmosphere. Consult an air-conditioning specialist or use a special extractor to recharge the system properly.
- Repair any leaks or defects in the engine cooling system or hydraulic system immediately.
- Do not increase the pressure in a pressurized circuit as this may lead to a component failure.
- Protect hoses during welding. Penetrating weld splatter may burn a hole or weaken hoses, allowing the loss of oils, coolant, etc.

Battery recycling

Batteries and electric accumulators contain several substances that can have a harmful effect on the environment if the batteries are not properly recycled after use. Improper disposal of batteries can contaminate the soil, groundwater, and waterways. CASE CONSTRUCTION strongly recommends that you return all used batteries to a CASE CONSTRUCTION dealer, who will dispose of the used batteries or recycle the used batteries properly. In some countries, this is a legal requirement.



Mandatory battery recycling

NOTE: The following requirements are mandatory in Brazil.

Batteries are made of lead plates and a sulfuric acid solution. Because batteries contain heavy metals such as lead, CONAMA Resolution 401/2008 requires you to return all used batteries to the battery dealer when you replace any batteries. Do not dispose of batteries in your household garbage.

Points of sale are obliged to:

- Accept the return of your used batteries
- Store the returned batteries in a suitable location
- Send the returned batteries to the battery manufacturer for recycling

Safety rules

Personal safety





This is the safety alert symbol. It is used to alert you to potential personal injury hazards. Obey all safety messages that follow this symbol to avoid possible death or injury.

Throughout this manual you will find the signal words DANGER, WARNING, and CAUTION followed by special instructions. These precautions are intended for the personal safety of you and those working with you.

Read and understand all the safety messages in this manual before you operate or service the machine.

 DANGER indicates a hazardous situation that, if not avoided, will result in death or serious injury.

 WARNING indicates a hazardous situation that, if not avoided, could result in death or serious injury.

 CAUTION indicates a hazardous situation that, if not avoided, could result in minor or moderate injury.

FAILURE TO FOLLOW DANGER, WARNING, AND CAUTION MESSAGES COULD RESULT IN DEATH OR SERIOUS INJURY.

Machine safety

NOTICE: Notice indicates a situation that, if not avoided, could result in machine or property damage.

Throughout this manual you will find the signal word Notice followed by special instructions to prevent machine or property damage. The word Notice is used to address practices not related to personal safety.

Information

NOTE: Note indicates additional information that clarifies steps, procedures, or other information in this manual.

Throughout this manual you will find the word Note followed by additional information about a step, procedure, or other information in the manual. The word Note is not intended to address personal safety or property damage.

Safety rules

**CALIFORNIA
PROPOSITION 65 WARNING**

Diesel engine exhaust and some of its constituents are known to the State of California to cause cancer, birth defects, and other reproductive harm.

Battery post, terminals and related accessories contain lead and lead compounds.

Wash hands after handling

BT09A213 1

Safety rules - Personal safety

Carefully study these precautions, and those included in the external attachment operators manual, and insist that they be followed by those working with and for you.

1. Thoroughly read and understand this manual and the attachment Operator's Manual before operating this or any other equipment.
2. Be sure all people and pets are clear of the machine before starting. Sound the horn, if equipped, three times before starting engine.
3. Only the operator should be on the machine when in operation. Never allow anyone to climb on to the machine while it is in motion. If the machine is equipped with an Instructors Seat, this must only be used for training purposes. Passengers must not be allowed to use the Instructors Seat.
4. Keep all shields in place. Never work around the machine or any of the attachments while wearing loose clothing that might catch on moving parts.
5. Observe the following precautions whenever lubricating the machine or making adjustments.
 - Disengage all clutching levers or switches.
 - Lower the attachment, if equipped, to the ground or raise the attachment completely and engage the cylinder safety locks. Completing these actions will prevent the attachment from lowering unexpectedly.
 - Engage the parking brake.
 - Shut off the engine and remove the key.
 - Wait for all machine movement to stop before leaving the operators platform.
6. Always keep the machine in gear while travelling downhill.
7. The machine should always be equipped with sufficient front or rear axle weight for safe operation.
8. Under some field conditions, more weight may be required at the front or rear axle for adequate stability. This is especially important when operating in hilly conditions or/when using heavy attachments.
9. Always lower the attachment, shut off the engine, set the parking brake, engage the transmission gears, remove the key and wait for all machine movement to stop before leaving the operators platform.
10. If the attachment or machine should become obstructed or plugged; set the parking brake, shut off the engine and remove the key, engage the transmission gears, wait for all machine or attachment motion to come to a stop, before leaving the operators platform to removing the obstruction or plug.
11. Never disconnect or make any adjustments to the hydraulic system unless the machine and/or the attachment is lowered to the ground or the safety lock(s) is in the engaged position.
12. Use of the flashing lights is highly recommended when operating on a public road.
13. When transporting on a road or highway, use accessory lights and devices for adequate warning to the operators of other vehicles. In this regard, check local government regulations. Various safety lights and devices are available from your CASE CONSTRUCTION dealer.
14. Practice safety 365 days a year.
15. Keep all your equipment in safe operating condition.
16. Keep all guards and safety devices in place.
17. Always set the parking brake, shut off the engine and remove the key, engage the transmission gears, wait for all machine or attachment motion to come to a stop, before leaving the operators platform to service the machine and attachment.
18. Remember: A careful operator is the best insurance against an accident.
19. Extreme care should be taken in keeping hands and clothing away from moving parts.

Basic instructions - Loader arm lock and cab tilt procedure - radial lift machines

SR210 TIER 4B (FINAL) [NGM418237 -]	
SR210 TIER 4B (FINAL) [NHM435463 -]	
SR240 TIER 4B (FINAL) [NGM418237 -]	
SR240 TIER 4B (FINAL) [NHM435463 -]	
TR270 TIER 4B (FINAL) [NGM418237 -]	
TR270 TIER 4B (FINAL) [NHM435463 -]	
TR310 TIER 4B (FINAL) [NGM418237 -]	
TR310 TIER 4B (FINAL) [NHM435463 -]	

⚠ DANGER

Crushing hazard!

Do not enter or exit the operator's compartment while the loader arms are raised or unsupported. Rest the loader arms on the ground or verify that loader arm is being supported by the loader arm strut or loader arm lock pin before entering or exiting the operator's compartment.

Failure to comply will result in death or serious injury.

D0168A

⚠ WARNING

Crushing hazard! Loader arms are unsupported during support strut removal.

Do not enter or exit the operator's compartment with an unsupported loader arm. Two persons are required during storage. One person should remove and store the support strut while the operator remains in the operator's compartment.

Failure to comply could result in death or serious injury.

W0077B

Raise and lock the loader arm for machine service

NOTE: An instructional decal on the inside of the right-hand loader arm, just above the support strut is also available. Understand the loader arm lock procedure before continuing.

1. Sit in the operator's seat, fasten the seat belt, pull down the restraint bar down, and start the engine.
2. Press the OPERATE button to enable the hydraulics.
3. Remove the bucket or attachment from the mounting plate.
4. Park the machine on firm and level surface.
5. If an assistant is not available, turn off the engine and exit the machine.
6. Remove the support strut pin (A) and let the support strut (B) rest on the lift cylinder barrel (C).

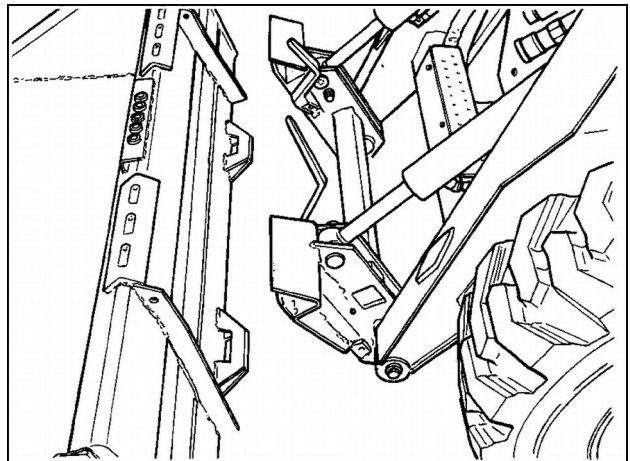

20092924 1

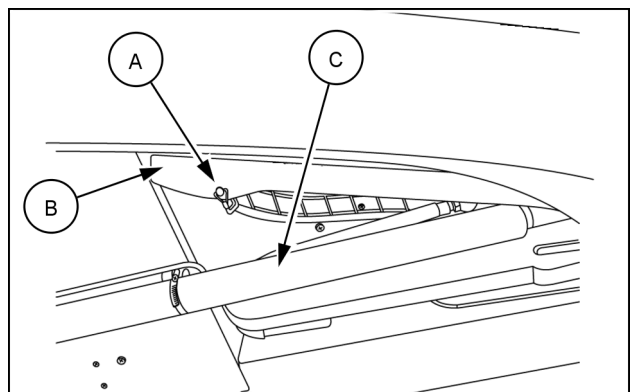

93106848A 2

INTRODUCTION

7. Slowly raise the loader arm until the support strut **(B)** falls onto the cylinder rod **(D)**.
8. Stop the engine.
9. Pull up on the override control knob (red control knob near the right-hand side of the operator's seat). The support strut **(B)** will brace against the top of the cylinder barrel **(C)**.
10. Ask an assistant to insert the pin **(A)** into the support strut **(B)**. If an assistant is not available visually confirm that the support strut is braced against the top of the cylinder barrel before exiting the machine.

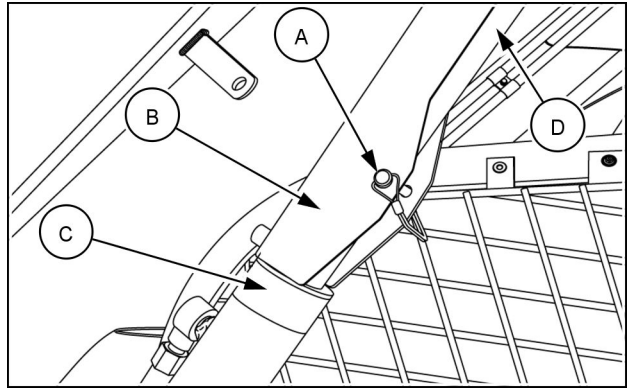

93106854A 3

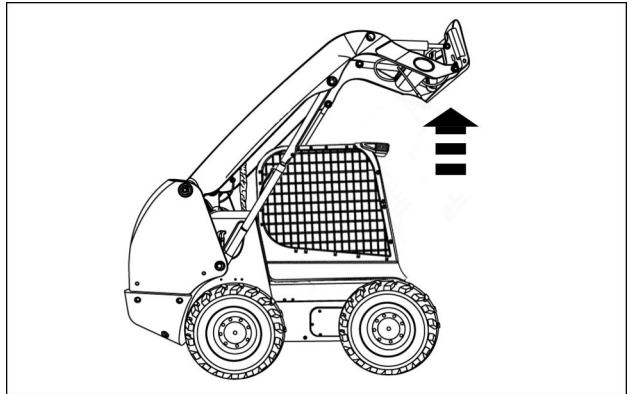

RAIL14SSL0418AA 4

Tilt and lock the cab forward for machine service

1. Remove the two, rear retaining nuts, located at the rear of the cab.

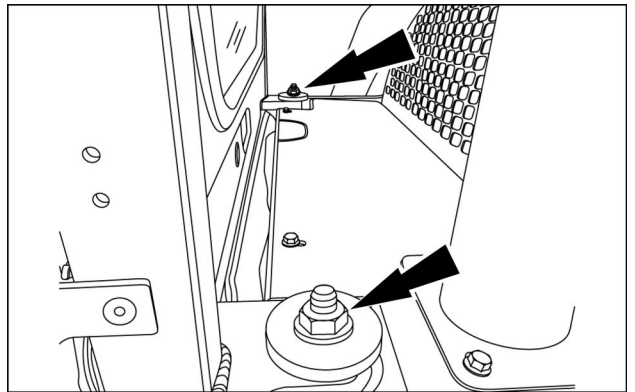

931001633 5

2. Pull on the hand holds at the front of the machine until the cab is completely tilted forward.

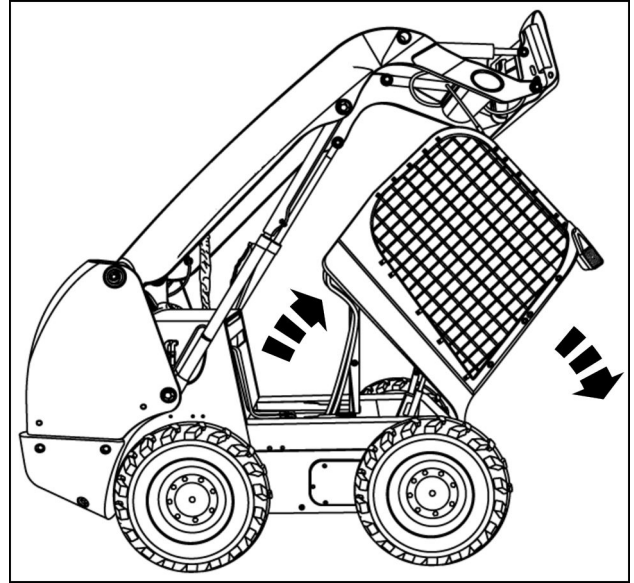

93107498 6

3. Confirm that the red lock tube has lowered over the cab pivot linkage. If it has the cab tilt position is now secure.

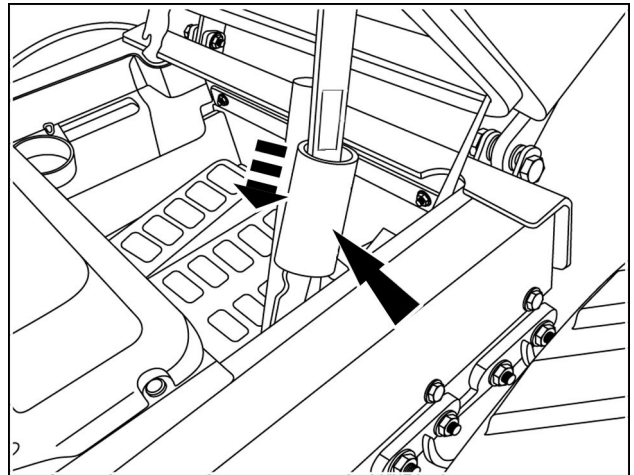

RAPH12SSL0420BA 7

Tilt and secure the cab for machine operation

1. Raise the red lock tube exposing the cab pivot linkage.
2. Push the cab backward into the operation position.

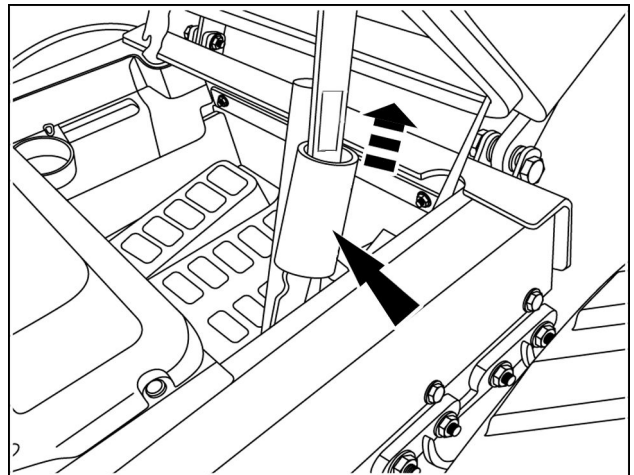

RAPH12SSL0420BA 8

3. Install the retaining nuts. Torque the nuts to **170 N·m (125 lb ft)**.

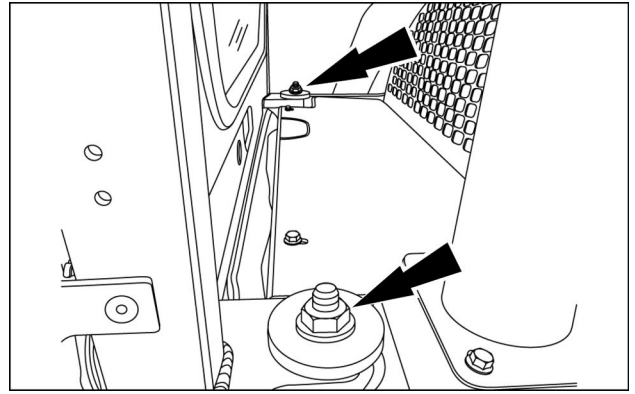

931001633 9

Unlock and lower the loader arm for machine operation

⚠ WARNING

Crushing hazard! Loader arms are unsupported during support strut removal. Do not enter or exit the operator's compartment with an unsupported loader arm. Two persons are required during storage. One person should remove and store the support strut while the operator remains in the operator's compartment. Failure to comply could result in death or serious injury.

W0077B

NOTE: An instructional decal on the inside of the right-hand loader arm, just above the support strut is also available. Understand the loader arm unlock procedure before continuing.

Placing the support strut in the storage position requires a second person. The operator must remain in the seat during this procedure.

1. Sit in the operator's seat, fasten the seat belt, pull down the restraint bar down, and start the engine.
2. Press the operate button to enable the hydraulics.
3. Raise the loader arm until the support strut **(B)** is not resting on the end of the cylinder barrel **(C)**.
4. Instruct the second person to remove the support strut pin **(A)** and place the support strut in the stowed position and reinstall the support strut pin **(A)**. When the second person has cleared the area, the operator may now lower the loader arm.
5. Commence work operations or park the machine and stop the engine.

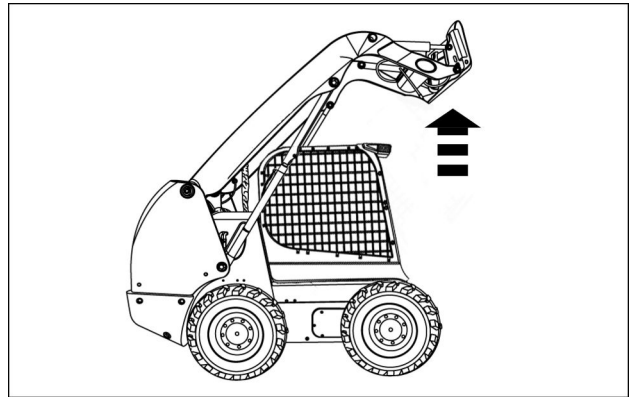

RAIL14SSL0418AA 10

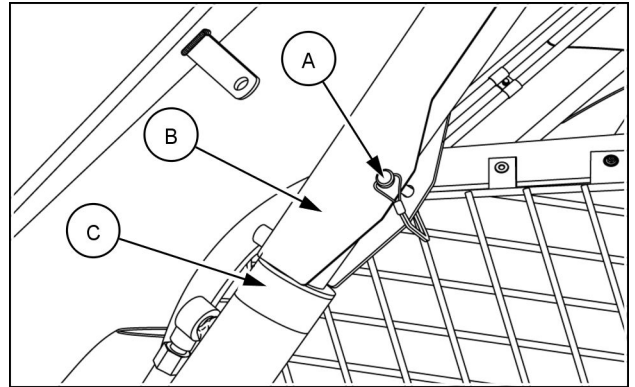

93106854A 11

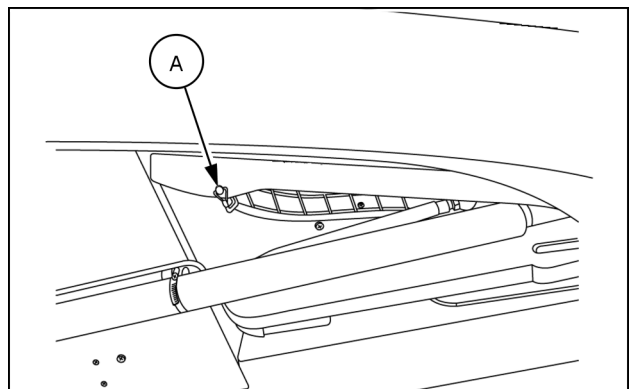

93106848A 12

Basic instructions - Loader arm lock and cab tilt procedure - vertical lift machines

SV280 TIER 4B (FINAL) [NGM418237 -]	
SV280 TIER 4B (FINAL) [NHM435463 -]	
TV370 TIER 4B (FINAL) [NHM435463 -]	

⚠ WARNING

Crushing hazard!

Do not enter or exit the operator's compartment while the loader arms are raised or unsupported. Rest the loader arms on the ground or verify that loader arm is being supported by the loader arm strut or loader arm lock pin before entering or exiting the operator's compartment.

Failure to comply could result in death or serious injury.

W1365A

Raise and lock the loader arm for machine service

1. Sit in the operator's seat, fasten the seat belt, pull down the restraint bar down, and start the engine.
2. Press the operate button to enable the hydraulics.
3. Remove the bucket or attachment from the mounting plate.
4. Park the machine on a level surface.

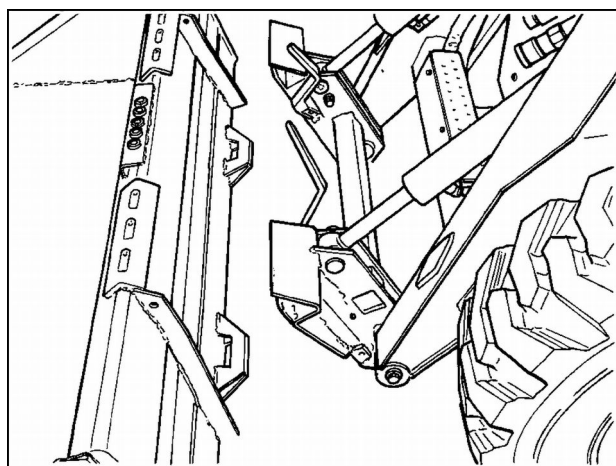

20092924 1

5. Fully raise the loader arm.

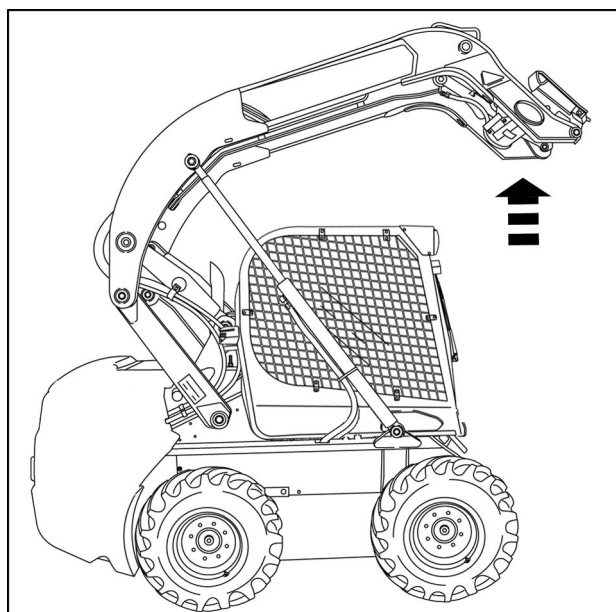

RAPH14SSL0351BA 2

INTRODUCTION

6. Locate the loader arm lock lever on the left-hand side of the operator's seat.
7. Rotate the lock lever toward the operator's seat (clockwise) to engage the lock support pin(s).
8. Stop the engine.

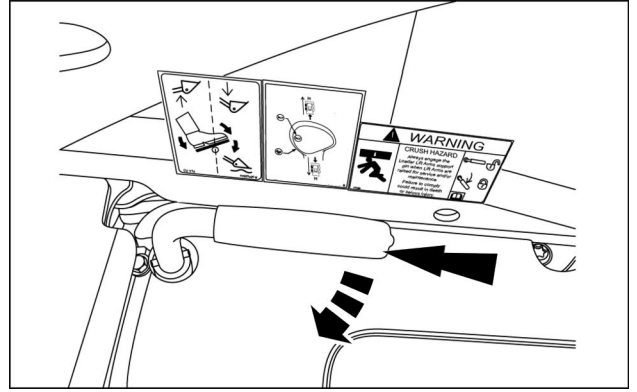

RAIL14SSL0429AA 3

9. Pull up on the override control knob (red control knob near the right-hand side of the operator's seat). The loader will brace against the lock support pin and keep the loader arm in a raised position.

NOTE: Only use the override control knob to lower the loader arm in emergency situations when engine power is not available or to lower it onto the lock support pin for servicing the machine.

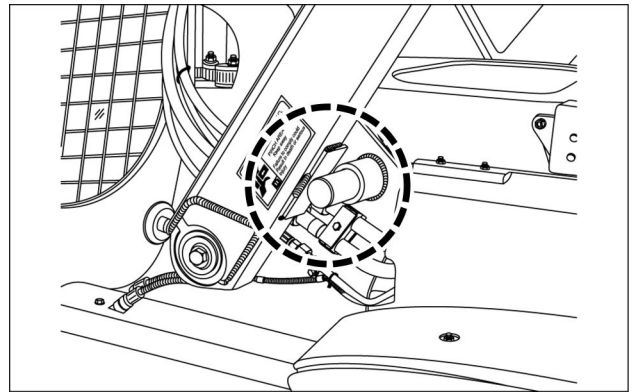

93107457 4

Tilt and lock the cab forward for machine service

1. Remove the two, rear retaining nuts, located at the rear of the cab.

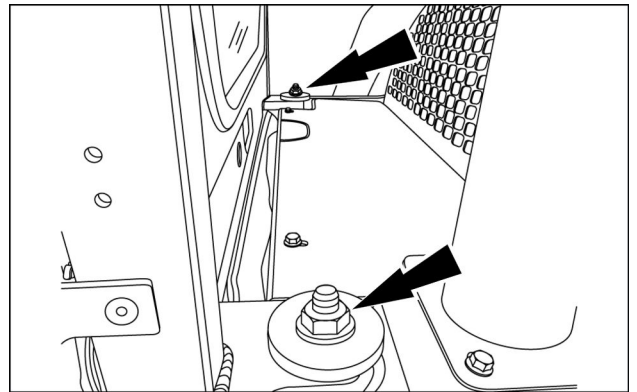

931001633 5

2. Pull on the hand holds at the front of the machine until the cab is completely tilted forward.

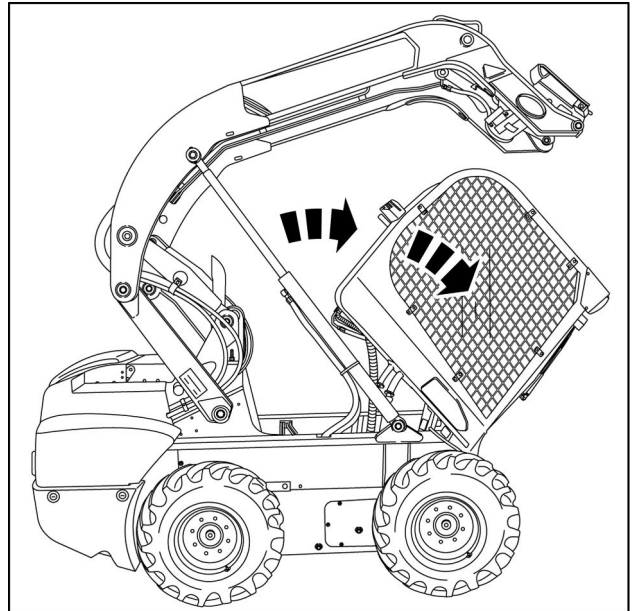

RAPH11SSL0016BA 6

3. Confirm that the red lock tube has lowered over the cab pivot linkage. If it has the cab tilt position is now secure.

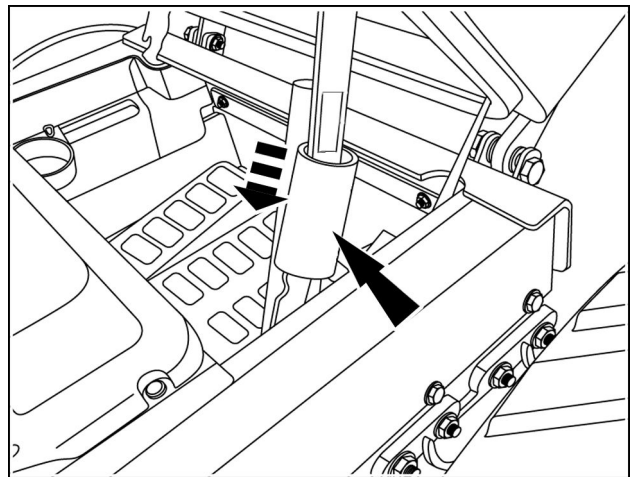

RAPH12SSL0420BA 7

Tilt and secure the cab for machine operation

1. Raise the red lock tube exposing the cab pivot linkage.
2. Push the cab backward into the operation position.

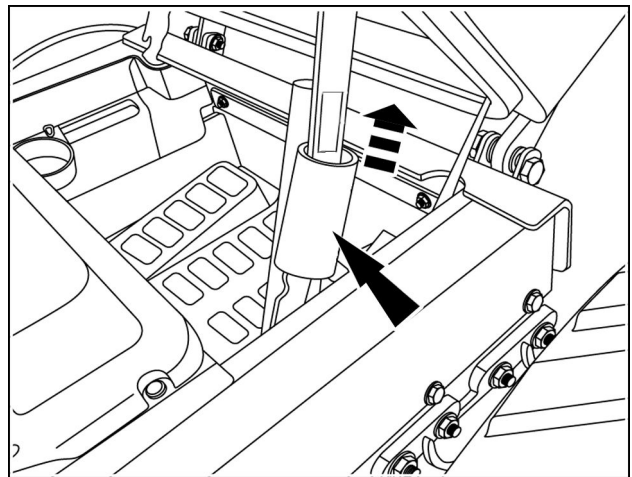

RAPH12SSL0420BA 8



Suggest:

If the above button click is invalid.

Please download this document

first, and then click the above link

to download the complete manual.

Thank you so much for reading

3. Install the retaining nuts. Torque the nuts to **170 N·m (125 lb ft)**.

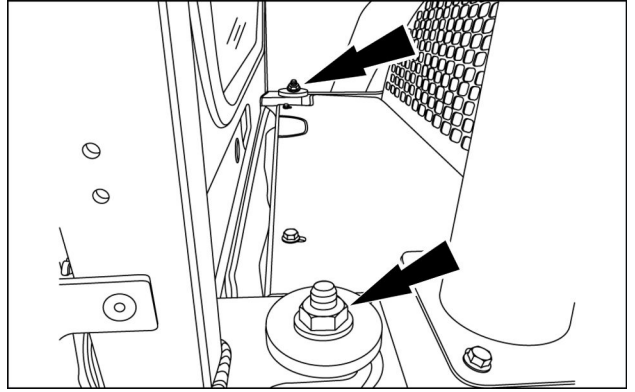

931001633 9

Unlock and lower the loader arm for machine operation

1. Sit in the operator's seat, fasten the seat belt, pull down the restraint bar down, and start the engine.
2. Press the operate button to enable the hydraulics.
3. Fully raise the loader arm.

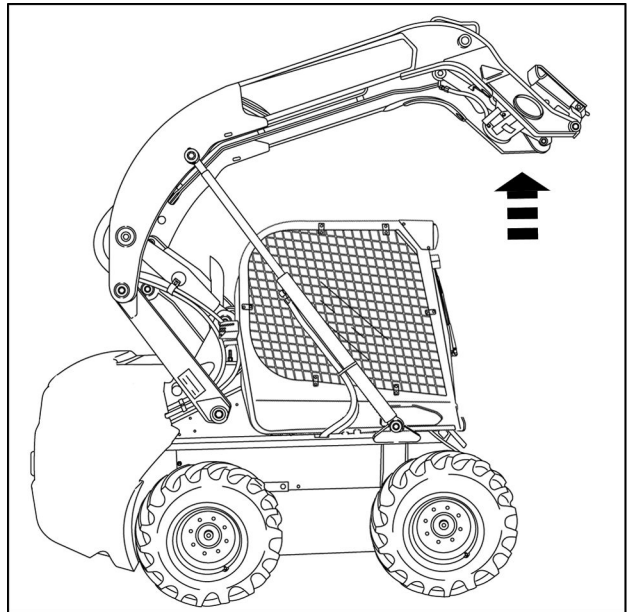

RAPH14SSL0351BA 10

4. Rotate the lock lever away from the seat (counter clockwise) to retract the lock pin(s).
5. Lower the loader arm.
6. Commence work operations or park the machine and stop the engine.

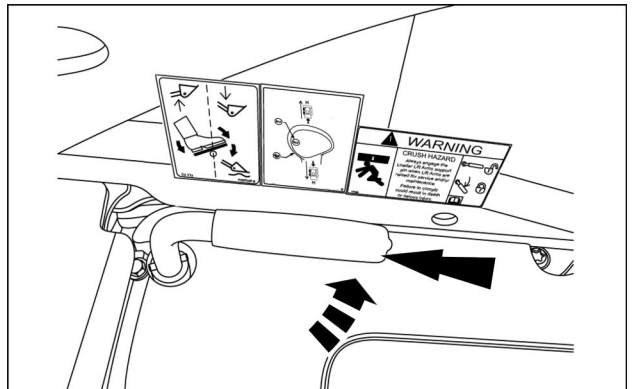

RAIL14SSL0429AA 11

<https://www.ebooklibonline.com>

Hello dear friend!

Thank you very much for reading.

Enter the link into your browser.

The full manual is available for immediate download.

<https://www.ebooklibonline.com>