

**TECHNICAL MANUAL
ORGANIZATIONAL MAINTENANCE**

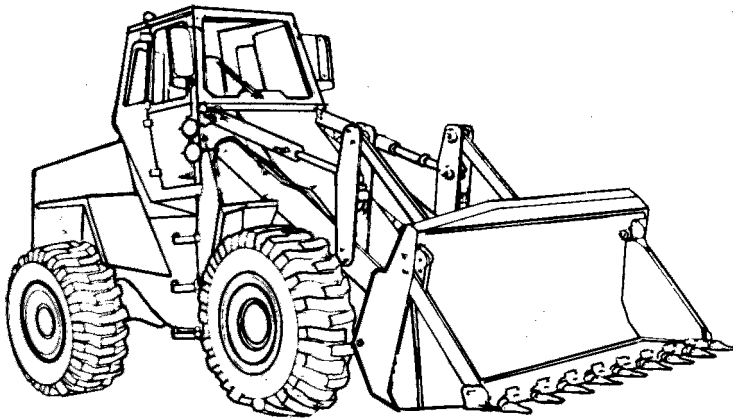

**LOADER, SCOOP TYPE, DED
4x4, ARTICULATED FRAME STEER,
2-1/2 CUBIC YARD
(J.I.CASE MODEL MW24C)
(NSN 3805-01-150-4814)**

TABLE OF CONTENTS PAGE i

HOW TO USE THIS MANUAL PAGE iii

**EQUIPMENT DESCRIPTION
AND DATA** PAGE 1-4

PRINCIPLES OF OPERATION PAGE 1-15

**PREVENTIVE MAINTENANCE CHECKS
AND SERVICES** PAGE 2-6

**TROUBLESHOOTING SYMPTOM
INDEX** PAGE 3-1

REFERENCES PAGE A-1

MAINTENANCE ALLOCATION CHART PAGE B-1

**EXPENDABLE/DURABLE SUPPLIES
AND MATERIALS LIST** PAGE C-1

MANUFACTURED ITEMS LIST PAGE D-1

**HYDRAULIC, PNEUMATIC, AND
ELECTRICAL DIAGRAMS** PAGE E-1

ALPHABETICAL INDEX PAGE INDEX 1

DISTRIBUTION STATEMENT A: Approved for public release. Distribution is unlimited.

WARNING

EXHAUST GASES CAN BE DEADLY

Exhaust gases can produce symptoms of headache, dizziness, loss of muscular control, or coma. Permanent brain damage or death can result from severe exposure. You can insure your safety by following these rules: DON'T operate the heater or engine in an enclosed area unless it is properly ventilated. DON'T drive with any of the loader's inspection plates, cover plates, or the hood off unless necessary for maintenance. If you notice exhaust odors or exposure symptoms, IMMEDIATELY VENTILATE the area.

If symptoms persist, remove the affected people and treat them:

- Expose them to fresh air.
- If necessary, give artificial respiration.
 - Keep them warm.
- DON'T permit physical exercise.

Refer to FM 21-11, First Aid for Soldiers, for first aid treatment of injured personnel.

WARNING

ROTATING FAN BLADES

Before working in area between radiator and engine, be sure engine is turned off. Failure to do so could cause serious injury to fingers or hand by rotating fan blade. If you injure your fingers or hand, obtain medical aid immediately.

WARNING

OIL UNDER PRESSURE

Hydraulic reservoir is pressurized. Shut off engine and operate hydraulic control valves before removing hydraulic reservoir fill cap. Failure to do so could cause serious injury or death.

WARNING

RETAINING/SNAP RINGS UNDER SPRING TENSION

Exercise care when removing retaining/snap rings. Some of these parts are under spring tension. Severe injury may result by the part striking your eye if you don't observe this precaution. If your eye is struck by a foreign object, seek medical aid immediately.

Hello

Thank you very much for your download.

In the last page of this PDF document.

There is a link.

Please click on that link and return to our website.

Then you can get the complete manual immediately.

No need to wait.

Thanks for continuing to read the documentation.

Best wishes.

WARNING

Toxic /FLAMMABLE

Dry cleaning solvent P-D-680 used to clean parts is toxic and flammable. Wear protective goggles and gloves and use only in a well ventilated area. Avoid contact with skin, eyes and clothes and don't breathe vapors. Do not use near open flame or excessive heat and don't smoke when using it. Failure to do so could cause serious injury. If you become dizzy while using cleaning solvent, get fresh air and medical attention immediately. If contact with skin or clothes is made, flush with large amounts of water. If contact with eyes is made, wash eyes with water and get medical aid immediately.

Starting fluid is toxic and highly flammable. Container is pressurized to act as an expellent. Don't heat container and don't discharge starting fluid in confined areas or near open flame. Don't discard used container in an open flame. To do any of the above will cause an explosion. Don't breathe ether vapor or allow ether to come in contact with your skin. To do so will cause severe injury or death.

WARNING

ELECTRICAL SHOCK HAZARD

Always disconnect battery ground cable before working on electrical components of this equipment. Death or severe injury may result if you fail to observe this precaution. If you receive an electrical shock, seek medical aid immediately.

WARNING

HIGH VELOCITY AIR

Compressed air used for cleaning purpose will not exceed 30 psi. Use only with effective chip guarding and personal protective equipment (goggles/shield, gloves, etc). Failure to do so could cause serious injury to eyes and possible blindness. If you hurt your eyes or if a foreign object is blown into your eyes, seek medical attention immediately.

WARNING

FALLING EQUIPMENT

When using chain hoist to remove or install parts, be sure chain hoist is securely fastened to the part and that all slack in chain is taken up. Failure to do so could cause serious injury due to the part falling on you. If you are injured by falling equipment, obtain medical aid immediately.

<https://www.ebooklibonline.com>

Hello dear friend!

Thank you very much for reading.

Enter the link into your browser.

The full manual is available for immediate download.

<https://www.ebooklibonline.com>

WARNING

NOISE HAZARD

Noise level exceeds 85 dB when operating loader with cab windows open or performing maintenance with engine operating. All personnel shall wear a hearing protective device when operating loader with windows open or performing loader maintenance with engine operating to prevent hearing loss.

WARNING

EXPLOSIVE HAZARD

Don't use jumper cables connected to battery terminals to start engine or charge batteries. Always use slave receptacle. Failure to do so could cause serious injury due to batteries exploding caused by improper connection of jumper cables to battery terminals.

WARNING

STEAM UNDER PRESSURE

Remove radiator cap slowly to relieve pressure before completely removing when engine is hot. Failure to do so could cause severe burns due to hot steam scalding. If you are scalded by hot steam, seek medical aid immediately.

WARNING

TIRE INFLATION

Check that tire is correctly mounted before inflating tire. Failure to do so may result in severe injury or death due to explosive separation of the tire and rim parts. If necessary, remove tire and install in a tire inflation cage. Always stand behind tire tread when inflating tire.

Do not inflate tire more than 40 psi. To do so may result in severe injury or death due to explosive separation of tire and rim parts. Stand behind tire tread and be sure personnel are not standing at side of tire before adding air. Failure to do so could cause severe injury or loss of life due to explosive separation of tire and rim parts.

WARNING

TIRE DEFLATION

Deflate tire completely before removing tire from rim. Refer to manual to completely deflate tire. Failure to follow this procedure could cause serious injury. If you are injured by not completely deflating tire, seek medical help immediately.

WARNING

JACKING LOADER

Make sure that loader will not roll or shift and that transport/service link is engaged before jacking loader. Secure with chock blocks. Death or serious injury may result by your failure to follow this procedure due to loader turning and slipping off jack or jack stands. If you are injured, obtain medical help immediately.

WARNING

Before starting engine, check and be sure that transport/service link is in released position. Failure to do so will cause loss of steering control which may result in serious injury or death and extensive property damage.

WARNING

Always use hand rails and steps when you mount or dismount loader. Don't use steering wheel or controls as a hand rail. Any other method of mounting or dismounting loader could make you slip and fall causing serious injury to yourself.

WARNING

Before moving loader up ramps, remove all ice, oil or grease from ramp to prevent loader from falling and causing death or serious injury and extensive damage to loader. Tell personnel to move away from loader.

WARNING

Don't allow personnel in or near the loader when it is being towed with the engine stopped. To do so could cause serious injury or death.

WARNING

Diesel fuel is highly combustible. Do not smoke or allow open flames or sparks into the area. Death or severe injury may result if personnel fail to observe this precaution. If you are burned, obtain medical aid immediately.

WARNING

Before performing any loader maintenance that requires servicing in area between front and rear chassis, be sure that transport/service link is engaged. Failure to do so could cause serious injury or death due to chassis pivoting and crushing you when you are working in area between front and rear chassis.

WARNING

Whenever a component or line in the brake system is disconnected for servicing, the air must be bled from the brake system. Failure to do so could cause serious injury or death due to loss of braking control.

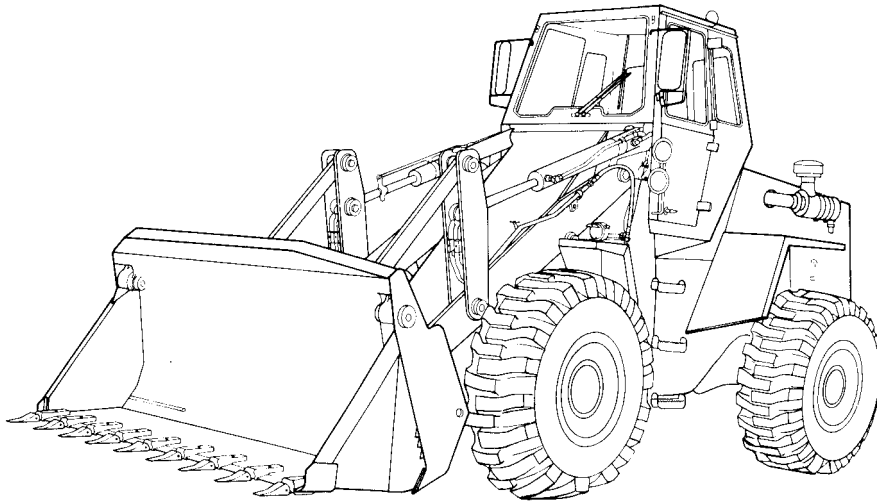

Left Front View

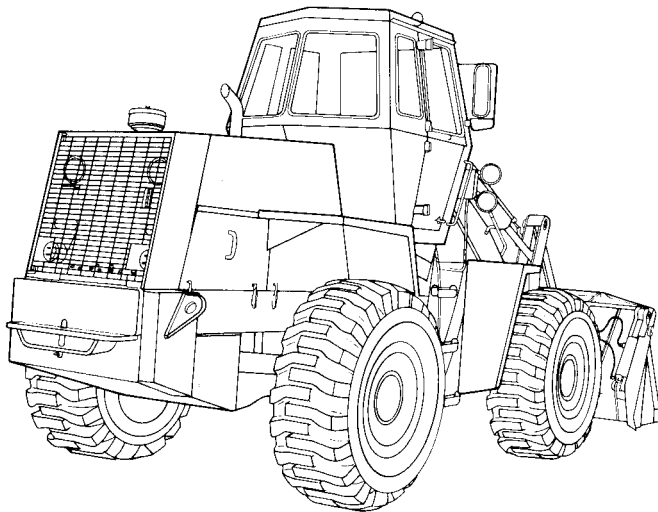

Right Rear View

MW24C Loader

TECHNICAL MANUAL
NO. 5-3805-262-20

HEADQUARTERS
DEPARTMENT OF THE ARMY
Washington D.C., 01 September 1987

ORGANIZATIONAL MAINTENANCE

**LOADER, SCOOP TYPE, DED, 4 X 4, ARTICULATED FRAME STEER,
2-1/2 CUBIC YARD**

**(J.I.CASE MODEL MW24C)
(NSN 3805-01-150-4814)**

REPORTING ERRORS AND RECOMMENDING IMPROVEMENTS

You can help improve this publication. If you find any errors, or if you would like to recommend any improvements to the procedures in this publication, please let us know. The preferred method is to submit your DA Form 2028 (Recommended Changes to Publications and Blank Forms) through the Internet, on the Army Electronic Product Support (AEPS) website. The Internet address is <https://aeps.ria.army.mil>. The DA Form 2028 is located under the Public Applications section in the AEPS Public Home Page. Fill out the form and click on SUBMIT. Using this form on the AEPS will enable us to respond quicker to your comments and better manage the DA Form 2028 program. You may also mail, E-mail, or fax your comments or DA Form 2028 directly to the U.S. Army TACOM Life Cycle Management Command. The postal mail address is U.S. Army TACOM Life Cycle Management Command, ATTN: AMSTA-LC-LMPP/TECH PUBS, 1 Rock Island Arsenal, Rock Island, IL 61299-7630. The E-mail address is tacomcmc.daform2028@us.army.mil. The fax number is DSN 793-0726 or Commercial (309) 782-0726.

TABLE OF CONTENTS

Page

CHAPTER 1	INTRODUCTION	1-1
	Chapter Overview	1-1
	Section I General Information	1-1
	Section II Equipment Description and Data	1-4
	Section III Principles of Operation	1-15
CHAPTER 2	MW24C LOADER MAINTENANCE	2-1
	Chapter Overview	2-1
	Section I Service Upon Receipt	2-1
	Section II Preventive Maintenance Checks and Services (PMCS)	2-6
	Section III Movement to a New Work Site	2-11
CHAPTER 3	TROUBLESHOOTING	3-1
	Chapter Overview	3-1
	Section I Troubleshooting Symptom Index	3-1
	Section II Troubleshooting	3-6
	Section II Troubleshooting using STE/ICE (Simplified Test Equipment for Internal Combustion Engines)	3-200
CHAPTER 4	ENGINE, FUEL, EXHAUST, AND COOLING SYSTEMS MAINTENANCE	4-1
	Chapter Overview	4-1
CHAPTER 5	ELECTRICAL SYSTEM MAINTENANCE	5-1
	Chapter Overview	5-1
CHAPTER 6	POWER TRAIN MAINTENANCE	6-1
	Chapter Overview	6-1

* This technical manual, in combination with TM 5-3805-262 series (-10, -24P, and -34) supersedes TM 5-3805-262-14&P-1 and TM 5-3805-262-14&P-2 in its entirety

TABLE OF CONTENTS

	Page
CHAPTER 7	BRAKE SYSTEM MAINTENANCE 7-1
	Chapter Overview 7-1
CHAPTER 8	WHEELS AND STEERING SYSTEM MAINTENANCE 8-1
	Chapter Overview 8-1
CHAPTER 9	FRAME AND TOWING ATTACHMENTS AND BODY AND CAB MAINTENANCE . . . 9-1
	Chapter Overview 9-1
CHAPTER 10	ACCESSORY ITEMS AND DATA PLATES MAINTENANCE 10-1
	Chapter Overview 10-1
CHAPTER 11	HYDRAULIC SYSTEM MAINTENANCE 11-1
	Chapter Overview 11-1
CHAPTER 12	SIGNALING DEVICES AND LOADER BUCKET ASSEMBLY MAINTENANCE . . . 12-1
	Chapter Overview 12-1
APPENDIX A	REFERENCES A-1
APPENDIX B	MAINTENANCE ALLOCATION CHART B-1
APPENDIX C	EXPENDABLE/DURABLE SUPPLIES AND MATERIALS LIST C-1
APPENDIX D	MANUFACTURED ITEMS LIST D-1
APPENDIX E	HYDRAULIC, PNEUMATIC, AND ELECTRICAL DIAGRAMS E-1
APPENDIX F	TORQUE LIMITS F-1
APPENDIX G	METRIC CONVERSIONS G-1
	GLOSSARY Glossary 1
	ALPHABETICAL INDEX Index 1

HOW TO USE THIS MANUAL

This manual is designed to help you operate and maintain the MW24C loader. It's divided into chapters, sections, and appendices. Chapter 1 contains general information, equipment description and data, and principles of operation of the loader. Chapter 2 contains data applicable to service to be performed on receipt of the loader, FMCS, and procedures to be followed when moving to a new work site. Chapter 3 contains troubleshooting information consisting of a symptom index and detailed troubleshooting procedures. Chapters 4 through 12 contain detailed maintenance procedures.

Appendices contain supplemental information which you require to maintain the loader.

Procedures in this manual tell you several things:

..... how to perform your PMCS and how often
 what tools you need to perform the job
 materials or parts required
 what condition the loader is to be in before work is started.

In addition to the text, you'll have either an assembled view or an exploded view illustration of the associated parts. Sometimes, the illustration will be keyed by an arrow to an overall view of the loader to help you determine the approximate location of the parts. The illustration is keyed to the text by numbers and shows you how to take the part off and put it on.

The following problem will show you some of the features of this manual:

PROBLEM

An operator brings his loader into the shop with an engine problem: The engine stalls frequently or doesn't develop full power. The best way to solve his problem is by using your manual. This is what you do:

1. How do you start?

Look at the cover of the manual.

On the cover you'll find a listing for TROUBLESHOOTING SYMPTOM INDEX. It tells you to go to page 3-1. To find page 3-1 fast, open the manual by using the black tab that lines up with the listing on the cover.

2. What kind of problem do you have?

Find it in the symptom index.

The symptom index is a list of problems covered by the section. It tells you that your problem "engine stalls frequently or doesn't develop full power" is covered in paragraph 3-4 MALFUNCTION entry number 6 on page 3-23. Directly beneath the MALFUNCTION entry number you'll also see a number enclosed in parentheses. This number refers to the paragraph and MALFUNCTION entry number where troubleshooting your problem is also covered using STE/ICE equipment if available. This troubleshooting using STE/ICE is covered on page 3-225.

HOW TO USE THIS MANUAL (CONT)

3. How do you determine what is causing the problem?

Go to page 3-23 or page 3-225 if you have STE/ICE, MALFUNCTION entry number 6.

There you'll find the troubleshooting procedures you'll need. The procedure has columns with the headings MALFUNCTION, TEST OR INSPECTION, and CORRECTIVE ACTION. Starting at step 1, read the procedure. Each step tells you what to do and what to look for. Follow the steps, in order, until you find your problem. When you find the problem, the CORRECTIVE ACTION column will tell you how to fix it.

4. Let's assume you've found that the air compressor is bad causing excessive drag on the engine. The procedure tells you to go to page 7-88. The procedure contains all the information you need to replace the air compressor. First check the introductory material. It tells what you'll need before you start the job. Within the detailed procedural text are illustrations showing you how to take out the air compressor and how to put it back in.

5. If on the other hand, you know what the problem is and its cause, refer to the alphabetical index located at the rear of this manual and find the name of the part to be replaced and its page number where maintenance procedures will be found. For example, the engine is overheating and on filling the radiator with water you see that water is pouring out the bottom radiator hose indicating that the hose requires replacement. Referring to the alphabetical index under the listing hoses, cooling system, page 4-74 is referenced. Turn to this page for hose removal procedure and following page(s) for installation procedure.

This manual has been designed so that you can quickly locate data you are looking for. Either look in the ALPHABETICAL INDEX for the subject matter, refer to the front cover index, table of contents, chapter index, or section index to locate the data.

CHAPTER 1 INTRODUCTION

CHAPTER OVERVIEW

The purpose of this chapter is to provide you with standard data required in all manuals, to familiarize you with the purpose and capabilities of the vehicle and to give you a brief description of its different systems and components.

Index

Section	Title	Page
I	General Information	1-1
II	Equipment Description and Data	1-4
III	Principles of Operation	1-15

Section I. GENERAL INFORMATION

	Para		Para
Scope	1-1	Reporting Equipment Improvement	
Maintenance Forms, Records, and		Recommendations (EIR)	1-7
Reports	1-2	Warranty Information	1-8
Destruction of Army Materiel to		Orientation	1-9
Prevent Enemy Use	1-3	Common Tools and	
Preparation for Storage or Shipment	1-4	Equipment	1-10
Quality Assurance/Quality Control		Special Tools, TMDE, and Support	
(QA/QC)	1-5	Equipment	1-11
Official Names and Nomenclature . .	1-6	Repair Parts	1-12
		Modification.	1-12.1

NOTE

The equipment described herein is non-metric and does not require metric common or special tools; therefore, metric units are not supplied. Tactical instructions for sake of clarity will also remain non-metric.

1-1. SCOPE

- a. Type of Manual. Organizational Maintenance Manual.
- b. Model Number and Equipment Name. MW24C 2-1/2 Cubic Yard Articulated Frame Steering 4 by 4 Diesel Engine Driven Scoop Type Loader.
- c. Purpose of Equipment. Loading trucks from stockpiles, stockpiling materiel, and excavating undisturbed and compacted soil. Unit also used as a clamshell to handle irregular shaped objects, as a dozer for general bulldozer work, and as a scraper.

1-2. MAINTENANCE FORMS, RECORDS, AND REPORTS

Department of the Army forms and procedures used for equipment maintenance will be those prescribed by DA PAM 738-750, The Army Maintenance Management System (TAMMS).

1-3. DESTRUCTION OF ARMY MATERIEL TO PREVENT ENEMY USE

Refer to TM 750-244-6.

1-4. PREPARATION FOR STORAGE OR SHIPMENT

Refer to TM 5-3805-262-10 for preparation for storage and page 2-13 of this manual for preparation for air transport instructions.

1-5. QUALITY ASSURANCE/QUALITY CONTROL

Quality assurance and quality control shall be in accordance with MIL-STD-109 and MIL-M-38784.

1-6. OFFICIAL NAMES AND NOMENCLATURE

The nomenclature, names, and designations used in this manual are in accordance with MIL-HDBK-63038-2 .

1-7. REPORTING EQUIPMENT IMPROVEMENT RECOMMENDATIONS (EIR)

If your MW24C loader needs improvement, let us know. Send us an EIR. You, the user, are the only one who can tell us what you don't like about your equipment. Let us know why you don't like the design. Put it on an SF 368 (Quality Deficiency Report). Mail it to us at: Commander, US Army Tank-Automotive Command, ATTN: AMSTA-MV, Warren, MI 48397-5000. We'll send you a reply.

1-8. WARRANTY INFORMATION

The MW24C loader is warranted by J.I. Case Company, Racine, Wisconsin for 15 months or 1500 hours of operation, whichever occurs first. Warranty starts on the date found on DA Form 2408-9 in the logbook and/or the equipment warranty data plate. Report all defects in material or workmanship to your supervisor who will take appropriate action.

1-9. ORIENTATION

The loader bucket is mounted at the front of the MW24C and the engine faces the rear. Controls for operating the bucket (lift, tilt, clam) are located to the right when you are sitting in the operator's seat. All references to right, left, front, or rear are from your viewpoint when you're sitting in the operator's seat.

1-10. COMMON TOOLS AND EQUIPMENT

For authorized common tools and equipment refer to the Modified Table of Organization and Equipment (MTOE) applicable to your unit.

1-11. SPECIAL TOOLS, TMDE, AND SUPPORT EQUIPMENT

No special tools are required. Tools, TMDE, and support equipment are listed in Section III of Appendix C.

1-12. REPAIR PARTS

Repair parts are listed and illustrated in the repair parts and special tools list TM 5-3805-262-24P covering organizational, direct support, and general support parts for the MW24C loader.

1-12.1 MODIFICATIONS

Refer to DAPAM 310-1 and DA PAM750-10 for all published Modification Work Orders which apply to the MW24C Scoop Loader. Refer to Department of the Army Modification Work Order MW05-3805-262-25-001 (effective 1988) for Installation of Alcohol Evaporator.

Section II. EQUIPMENT DESCRIPTION AND DATA

	Para
Equipment Characteristics, Capabilities, and Features	1-13
Location and Description of Major Components and Plates	1-14
Equipment Data	1-15
Safety, Care, and Handling	1-16

1-13. EQUIPMENT CHARACTERISTICS, CAPABILITIES, AND FEATURES

a. Purpose of MW24C Loader. Loading trucks and railcars from stockpiles, stockpiling materiel, and excavating undisturbed and compacted soil. Unit also used as a clamshell to handle irregular shaped objects, as a dozer for general bulldozer work, and as a scraper.

b. Capabilities and Features.

- (1) Two and one-half yard capacity bucket.
- (2) Operates over rough terrain.
- (3) Four speed ranges in forward; two speed ranges in reverse.
- (4) Declutch pedal disengages transmission during loader operation to provide maximum hydraulic power when needed.
- (5) Diesel engine driven.
- (6) Power steering.
- (7) Power assisted air over hydraulic brakes.
- (8) Enclosed operator's compartment.
- (9) Auxiliary steering automatically cuts-in if primary steering is disabled.
- (10) Bucket height control to automatically stop loader lift arms at a preselected dump height.
- (11) Bucket return-to-dig control to automatically return bucket to preselected position.
- (12) Four-in-one bucket used as a scraper, blade, clamshell, or standard bucket .
- (13) Ford depths up to 30 inches.
- (14) Collapsible steering wheel for air transport.

1-14. LOCATION AND DESCRIPTION OF MAJOR COMPONENTS AND PLATES

a. Location and Description of Major Components.

ENGINE. J.I. Case Model A504BD Diesel engine having a displacement of 504 cubic inches. Accessories mounted on and considered a part of the engine include the alternator, air compressor, starting motor, fuel injection pump, and fuel filters.

FUEL SYSTEM. Consists of fuel injectors, fuel injection pump, electric fuel pump, air cleaner, fuel filters, and cold start kit.

EXHAUST SYSTEM. Consists of muffler and exhaust pipe. Muffler mounted on top of engine.

COOLING SYSTEM. Includes radiator mounted in rear of loader, thermostat and housing, engine driven water pump, and fan.

1-14. LOCATION AND DESCRIPTION OF MAJOR COMPONENTS AND PLATES (CONT)

a. Location and Description of Major Components.

ELECTRICAL SYSTEM, 24 volt, negative ground, Includes engine driven alternator, starter motor, instrument panels, light system, and two 12 volt batteries connected in series,

BRAKES. Disk brakes, air over hydraulic. Air actuated drum type parking brake located on transmission output shaft.

STEERING SYSTEM. Consists of steering wheel, steering column and gear, and two steering cylinders. Power assist provided by hydraulic pump mounted on and driven by transmission. Also includes auxiliary steering system.

FRAME AND TOWING ATTACHMENTS. Two section frame consisting of front and rear chassis; drawbar pin located at rear of loader.

SIGNALING DEVICES, Consists of back-up alarm and turn signals. Back-up,alarm located at rear of loader; sounds when transmission is shifted into reverse. Turn signals located at top of cab; turn signal switch mounted on steering column.

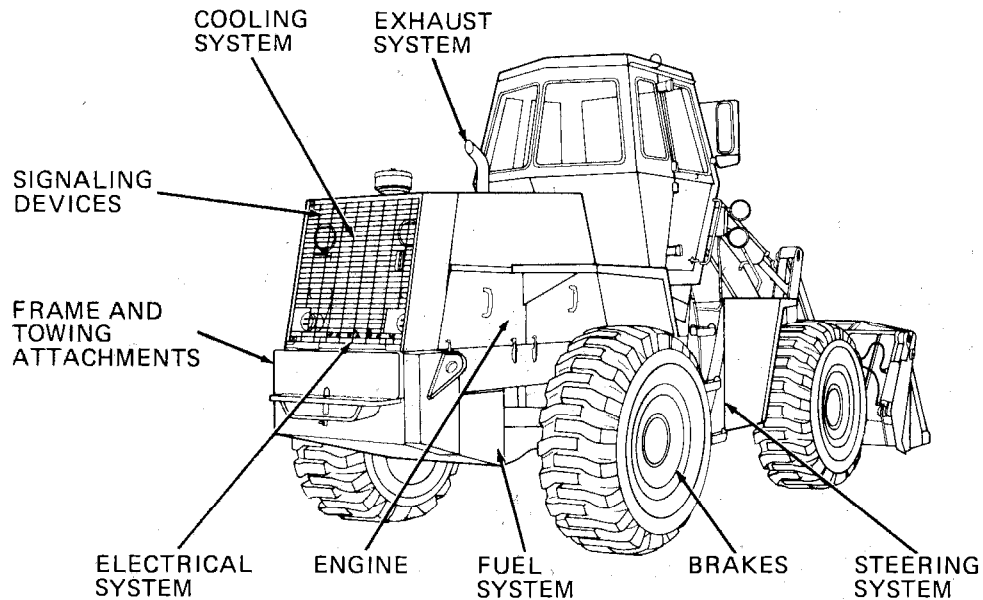

1-14. LOCATION AND DESCRIPTION OF MAJOR COMPONENTS AND PLATES (CONT)

a. Location and Description of Major Components (Cont).

TRANSMISSION AND DRIVE SHAFTS. Four speeds in forward and two speeds in reverse. Has declutch feature which permits neutralizing transmission. Three drive shafts used to transmit power to front and rear axles.

AXLES AND WHEELS. Standard planetary axles; pneumatic tires.

CAB. Fully enclosed and removable for shipment purposes when necessary. With doors, windows, and front and rear windshields.

ACCESSORIES. Includes air horn and control valve, windshield washer and wiper, outside mirrors, heater, and fan defrosters.

HYDRAULIC SYSTEM. Consists of hydraulic main pump assembly/steering pump, control valve assembly, hydraulic cylinders (lift arm, bucket tilt, and clam), hydraulic reservoir, and hydraulic filter.

EARTHMOVING COMPONENTS. Includes bucket lift arms and pivot assemblies and loader bucket assembly.

b. Location of Identification, Instruction, and Warranty Plates. For location of identification, instruction, and warranty plates, refer to illustrations on following pages.

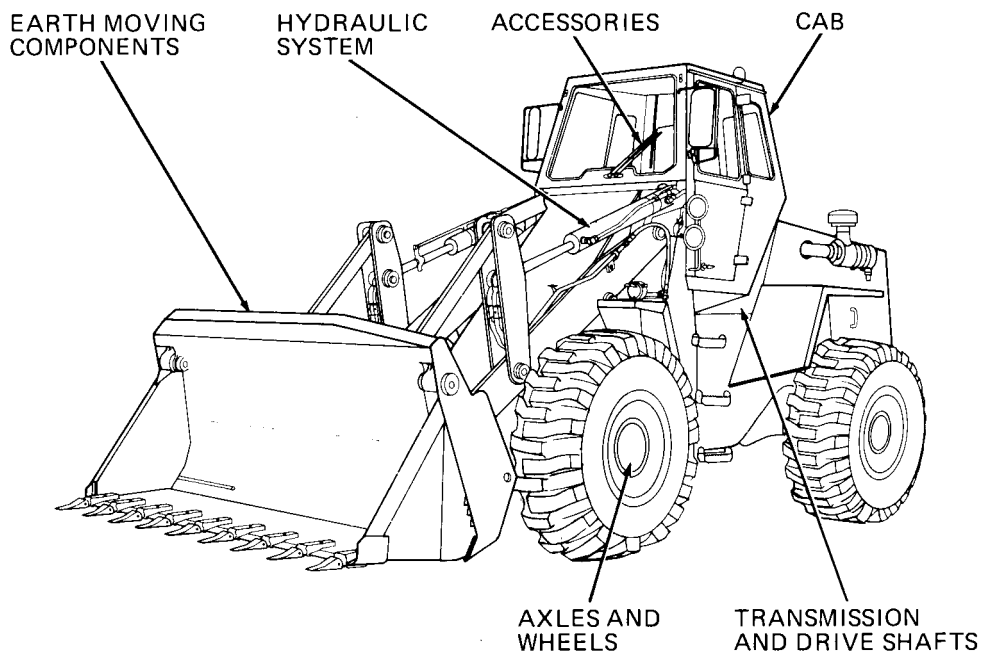

1-14. LOCATION AND DESCRIPTION OF MAJOR COMPONENTS AND PLATES (CONT)

b. Location of Identification, Instruction, and Warranty Plates (Cont).

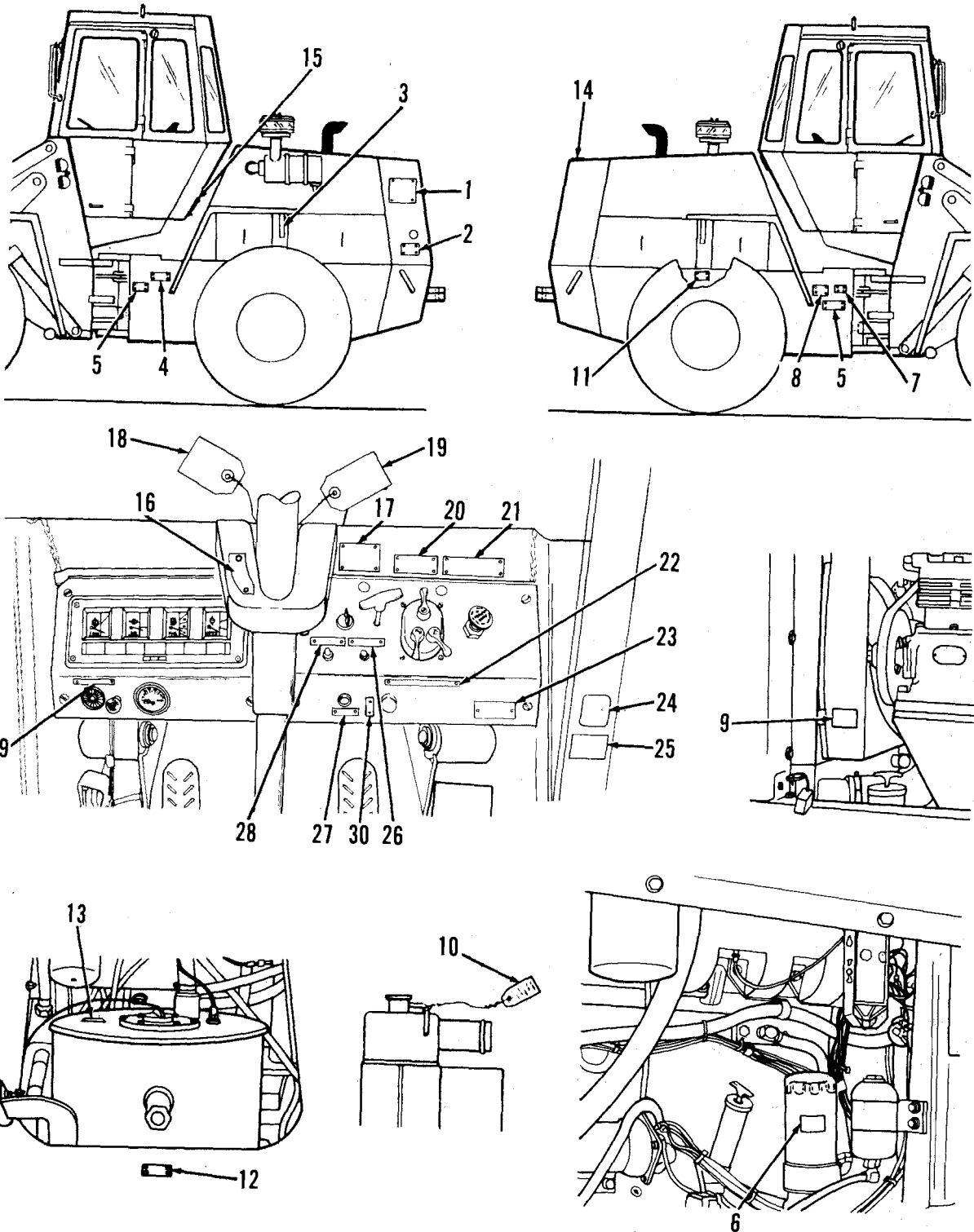

1-14. LOCATION AND DESCRIPTION OF MAJOR COMPONENTS AND PLATES (CONT)

b. Location of Identification, Instruction, and Warranty Plates (Cont).

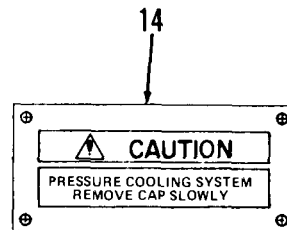
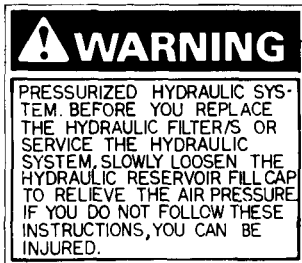
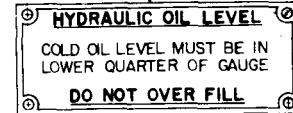
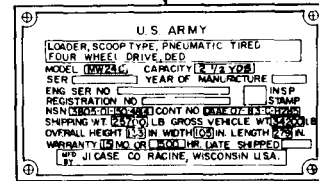
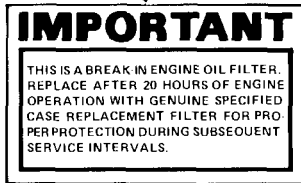
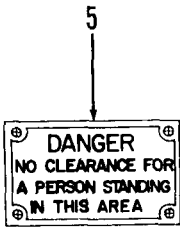
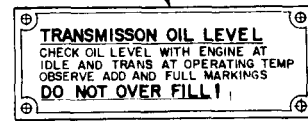
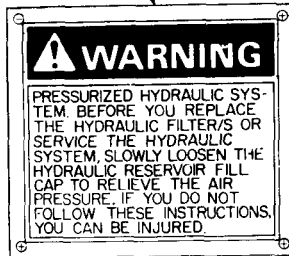
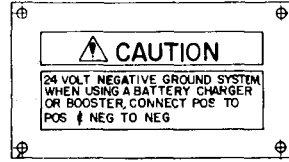
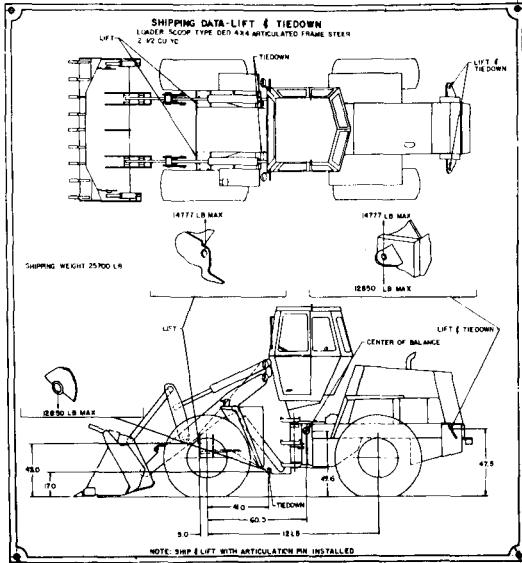

TM 5-3805-262-20

1-15. EQUIPMENT DATA

Equipment data is tabulated below.

Manufacturer J.I. Case
 Model MW24C

DIMENSIONS AND WEIGHT

Overall operating height (A)	16 feet, 1-1/2 inches
Dump clearance at maximum height, 45 degrees dump (B)	9 feet
Dump reach at maximum height, 45 degrees dump (C)	3 feet, 1 inch
Dump reach at 7 feet dump height, 45 degrees dump (D)	4 feet, 5 inches
Height to bucket hinge pin (E)	12 feet, 2-1/2 inches
Maximum shipping height (F)	10 feet, 10-1/2 inches
Overall length, bucket on ground (G)	22 feet, 5-1/2 inches
Overall width	94-1/2 inches
Wheel base (H)	10 feet, 1-1/2 inches
Tire tread	77 inches
Ground clearance (I)	16 inches
Height to top of steering wheel (J)	106-1/2 inches
Overall height without cab	106-1/2 inches
Width overtires	100 inches
Total weight	25,900 pounds
Front axle weight	12,750 pounds
Rear axle weight	13,150 pounds
Center of gravity location	44 inches high; 61.7 inches back from center of front axle

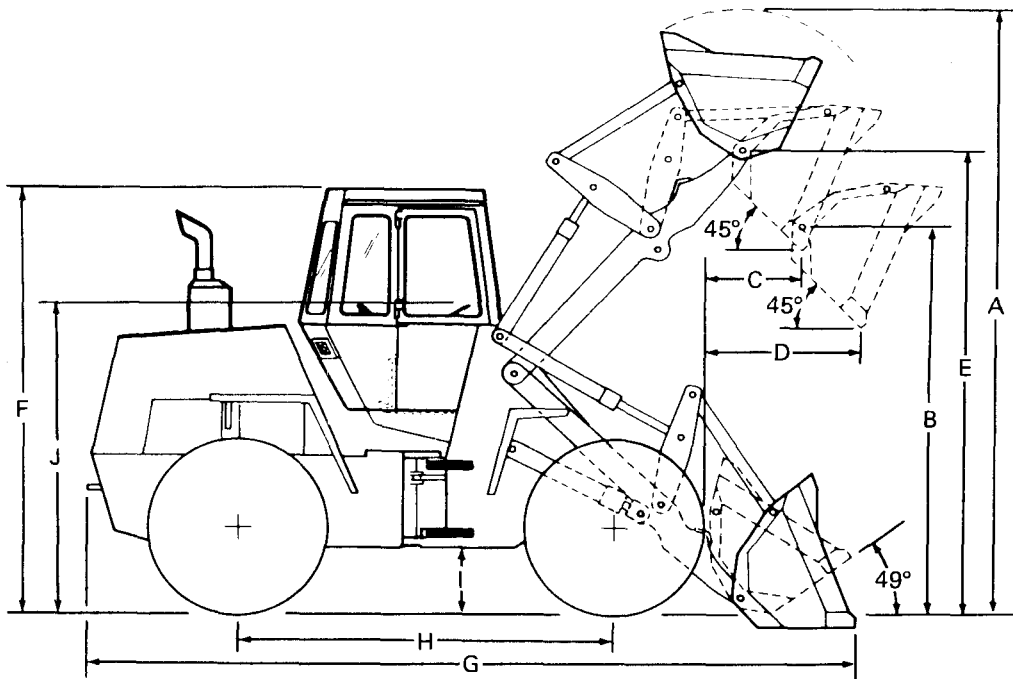

1-15. EQUIPMENT DATA (CONT)

ENGINE LUBRICATING SYSTEM (CONT)

Type System Pressure and Spray Circulation
Oil Pump Gear Type
Oil Filter Full Flow Turn on Type

FUEL SYSTEM

Fuel Injection Pump Robert Bosch, Type PES Multiple Plunger
Pump Timing 27 Degrees Before Top Dead Center (Port Closing)
1st Stage Fuel Filter Full Flow Turn on Type
2nd Stage Fuel Filter Full Flow Turn on Type
Operating Pressure 20 to 30 psi

ALTERNATOR

Manufacturer Delco-Remy
Part Number 1100077
Rating 65 ampere

AIR COMPRESSOR

Manufacturer Midland Ross
Part Number N5303AA
Number of Cylinders 2

RADIATOR

Manufacturer General 22-4173
. Young E299000

ELECTRICAL SYSTEM

Electrical system voltage 24volts
Batteries (2) 12 volt
Replacement Bulbs Bulb Number
Warning lamp for hydraulic filters 1895R
Cab lamp 93 or 1591
Stop and tail lamp 1683
Instrument panel lamp 363
Directional and flasher lamp 307
Driving lamps 4880
Flood lamps 4578
Instrument cluster lamps 194

BUCKET

Width 104 inches
SAE Rated Capacity 2.5 yards

HYDRAULIC SYSTEM

Reservoir Positive pressurization
Control Valve
Manufacturer Parker
Model VDPS24DRF36
Type Open center series
Relief Valve Setting 2300 psi



Suggest:

If the above button click is invalid.

Please download this document

first, and then click the above link

to download the complete manual.

Thank you so much for reading

1-15. EQUIPMENT DATA (CONT)

HYDRAULIC SYSTEM (CONT)

Hydraulic Pump

Manufacturer Commercial Shearing Inc.
 Model 313-9622-451
 Flow at 2200 rpm and 2300 psi 52 gallons per minute
 Pressure 2500 psi

Steering Pump

Flow at 2200 rpm and 2000 psi 23 gallons per minute
 Pressure 2000 psi

Hydraulic Cylinders

Tilt 4.50 inch diameter x 29.50 inch stroke x 2.50 inch rod
 Lift 5.0 inch diameter x 34.625 inch stroke x 3.0 inch rod
 Steering 3.0 inch diameter x 15.0 inch stroke x 1.25 inch rod
 Clam 4.0 inch diameter x 10.5 inch stroke x 2.0 inch rod

Auxiliary Steering Motor and Pump

Manufacturer Parker Hannifin
 Part Number D27AR1A-022
 Type 24 volts/6.4 gpm @ 2000 psi

AIR CLEANER

Manufacturer Donaldson
 Part Number FHG09-0023
 Type Dry - 2 Stage

STARTER

Manufacturer Delco-Remy
 Part Number 1114872
 clutch Sprag type

TRANSMISSION

Manufacturer Allison
 Model TT-2421-1
 Type Full power shift
 Ratio
 Forward Low Range - 1st 2.6 MPH
 Forward Low Range - 2nd 6.5 MPH
 Forward High Range - 3rd 11.4 MPH
 Forward High Range - 4th 22.2 MPH
 Reverse 1st 3.6 MPH
 Reverse 2nd 8.7MPH

TORQUE CONVERTER

Manufacturer Allison
 Model Integral TT425
 Stall Ratio 4.92:1

AXLES

Manufacturer Rockwell
 Model
 Front Standard planetary, disk brakes
 Rear Standard planetary, disk brakes

<https://www.ebooklibonline.com>

Hello dear friend!

Thank you very much for reading.

Enter the link into your browser.

The full manual is available for immediate download.

<https://www.ebooklibonline.com>