

**WD1904
WD2304
Tier 3**
Self-Propelled Windrower

SERVICE MANUAL

Part number 47904538

1st edition English

July 2015



Link Product / Engine

Product	Market Product	Engine
WD1904 [- YFG676501]	North America	F4HE9687
WD2304 [- YFG676501]	North America	F4HE9687

Contents

INTRODUCTION

Engine	10
[10.001] Engine and crankcase	10.1
[10.202] Air cleaners and lines	10.2
[10.206] Fuel filters	10.3
[10.216] Fuel tanks	10.4
[10.218] Fuel injection system.....	10.5
[10.250] Turbocharger and lines.....	10.6
[10.254] Intake and exhaust manifolds and muffler	10.7
[10.400] Engine cooling system	10.8
[10.414] Fan and drive	10.9
Front axle system	25
[25.310] Final drives	25.1
Rear axle system	27
[27.550] Non-powered rear axle.....	27.1
Hydrostatic drive	29
[29.100] Transmission and steering hydrostatic control	29.1
[29.202] Hydrostatic transmission	29.2
[29.218] Pump and motor components.....	29.3
Brakes and controls	33
[33.110] Parking brake or parking lock	33.1
Hydraulic systems	35
[35.000] Hydraulic systems.....	35.1
[35.100] Main lift system.....	35.2
[35.105] Charge pump.....	35.3
[35.220] Auxiliary hydraulic pump and lines	35.4

<https://www.ebooklibonline.com>

Hello dear friend!

Thank you very much for reading.

Enter the link into your browser.

The full manual is available for immediate download.

<https://www.ebooklibonline.com>

[35.300] Reservoir, cooler, and filters.....	35.5
[35.304] Combination pump units	35.6
[35.410] Header or attachment height system	35.7
[35.415] Header or attachment tilting system	35.8
[35.760] Header reverser drive	35.9
[35.910] Head and header hydraulic drive	35.10
Steering.....	41
[41.101] Steering control	41.1
Cab climate control	50
[50.200] Air conditioning	50.1
Electrical systems	55
[55.000] Electrical system	55.1
[55.019] Hydrostatic drive control system	55.2
[55.050] Heating, Ventilation, and Air-Conditioning (HVAC) control system.....	55.3
[55.100] Harnesses and connectors.....	55.4
[55.640] Electronic modules.....	55.5
[55.DTC] FAULT CODES.....	55.6
Platform, cab, bodywork, and decals	90
[90.124] Pneumatically-adjusted operator seat.....	90.1
[90.150] Cab.....	90.2
[90.151] Cab interior.....	90.3
[90.154] Cab doors and hatches	90.4



INTRODUCTION

Safety rules

WD1904	NA
WD2304	NA

Personal safety





This is the safety alert symbol. It is used to alert you to potential personal injury hazards. Obey all safety messages that follow this symbol to avoid possible death or injury.

Throughout this manual you will find the signal words DANGER, WARNING, and CAUTION followed by special instructions. These precautions are intended for the personal safety of you and those working with you.

Read and understand all the safety messages in this manual before you operate or service the machine.

 DANGER indicates a hazardous situation that, if not avoided, will result in death or serious injury.

 WARNING indicates a hazardous situation that, if not avoided, could result in death or serious injury.

 CAUTION indicates a hazardous situation that, if not avoided, could result in minor or moderate injury.

FAILURE TO FOLLOW DANGER, WARNING, AND CAUTION MESSAGES COULD RESULT IN DEATH OR SERIOUS INJURY.

Machine safety

NOTICE: Notice indicates a situation that, if not avoided, could result in machine or property damage.

Throughout this manual you will find the signal word Notice followed by special instructions to prevent machine or property damage. The word Notice is used to address practices not related to personal safety.

Information

NOTE: Note indicates additional information that clarifies steps, procedures, or other information in this manual.

Throughout this manual you will find the word Note followed by additional information about a step, procedure, or other information in the manual. The word Note is not intended to address personal safety or property damage.

Safety rules

WD1904	NA
WD2304	NA

General safety rules

Use caution when operating the machine on slopes. Raised equipment, full tanks and other loads will change the center of gravity of the machine. The machine can tip or roll over when near ditches and embankments or uneven surfaces.

- Only skilled operators who are familiar with all the controls and harvesting techniques should use the equipment. It is recommended to operate on cultivated land with slopes no greater than **26 % (15 °)** uphill and downhill.
- If necessary, when driving downhill change into a lower gear before starting the descent. Machine must be stopped to downshift into a lower gear.

Never permit anyone other than the operator to ride on the machine.

Never operate the machine under the influence of alcohol, drugs, or while otherwise impaired.

Pay attention to overhead power lines and hanging obstacles. High voltage lines may require significant clearance for safety.

Hydraulic oil or diesel fuel leaking under pressure can penetrate the skin, causing serious injury or infection.

- DO NOT use your hand to check for leaks. Use a piece of cardboard or paper.
- Stop engine, remove key and relieve the pressure before connecting or disconnecting fluid lines.
- Make sure all components are in good condition and tighten all connections before starting the engine or pressurizing the system.
- If hydraulic fluid or diesel fuel penetrates the skin, seek medical attention immediately.
- Continuous long term contact with hydraulic fluid may cause skin cancer. Avoid long term contact and wash the skin promptly with soap and water.

Keep clear of moving parts. Loose clothing, jewelry, watches, long hair, and other loose or hanging items can become entangled in moving parts.

Wear protective equipment when appropriate.

DO NOT attempt to remove material from any part of the machine while it is being operated or components are in motion.

Make sure all guards and shields are in good condition and properly installed before operating the machine. Never operate the machine with shields removed. Always close access doors or panels before operating the machine.

Dirty or slippery steps, ladders, walkways, and platforms can cause falls. Make sure these surfaces remain clean and clear of debris.

A person or pet within the operating area of a machine can be struck or crushed by the machine or its equipment. DO NOT allow anyone to enter the work area.

Raised equipment and/or loads can fall unexpectedly and crush persons underneath. Never allow anyone to enter the area underneath raised equipment during operation.

Never operate engine in enclosed spaces as harmful exhaust gases may build up.

Before starting the machine, be sure that all controls are in neutral or park lock position.

Start the engine only from the operator's seat. If the safety start switch is bypassed, the engine can start with the transmission in gear. Do not connect or short across terminals on the starter solenoid. Attach jumper cables as described in the manual. Starting in gear may cause death or serious injury.

Always keep windows, mirrors, all lighting, and Slow Moving Vehicle (SMV) emblem clean to provide the best possible visibility while operating the machine.

Operate controls only when seated in the operator's seat, except for those controls expressly intended for use from other locations.

Before leaving the machine:

1. Park machine on a firm level surface.
2. Put all controls in neutral or park lock position.
3. Engage park brake, use wheel chocks if required.
4. Lower all hydraulic equipment — Implements, header, etc.
5. Turn off engine and remove key.

When, due to exceptional circumstances, you would decide to keep the engine running after leaving the operator's station, then the following precautions must be followed:

1. Bring the engine to low idle speed.
2. Disengage all drive systems.

3. **⚠ WARNING**

**Some components may continue to run down after disengaging drive systems.
Make sure all drive systems are fully disengaged.
Failure to comply could result in death or serious injury.**

W0113A

Shift the transmission into neutral.

4. Apply the parking brake.

⚠ General maintenance safety ⚠

Keep area used for servicing the machine clean and dry. Clean up spilled fluids.

Service machine on a firm level surface.

Install guards and shields after servicing the machine.

Close all access doors and install all panels after servicing the machine.

Do not attempt to clean, lubricate, clear obstructions or make adjustments to the machine while it is in motion or while the engine is running.

Always make sure working area is clear of tools, parts, other persons and pets before you start operating the machine.

Unsupported hydraulic cylinders can lose pressure and drop the equipment causing a crushing hazard. Do not leave equipment in a raised position while parked or during service, unless securely supported.

Jack or lift the machine only at jack or lift points indicated in this manual.

Incorrect towing procedures can cause accidents. When towing a disabled machine follow the procedure in this manual. Use only rigid tow bars.

Stop the engine, remove key and relieve pressure before disconnecting or connecting fluid lines.

Stop the engine and remove key before disconnecting or connecting electrical connections.

Scalding can result from incorrect removal of coolant caps. Cooling system operates under pressure. Hot coolant can spray out if a cap is removed while the system is hot. Allow system to cool before removing cap. When removing a cap turn it slowly to allow pressure to escape before completely removing the cap.

Replace damaged or worn tubes, hoses, electrical wiring, etc.

Engine, transmission, exhaust components, and hydraulic lines may become hot during operation. Take care when servicing such components. Allow surfaces to cool before handling or disconnecting hot components. Wear protective equipment when appropriate.

When welding, follow this instructions in the manual. Always disconnect the battery before welding on the machine. Always wash your hands after handling battery components.

Wheels and tires

Make sure tires are correctly inflated. Do not exceed recommended load or pressure. Follow instructions in the manual for proper tire inflation.

Tires are heavy. Handling tires without proper equipment could cause death or serious injury.

Always have a qualified tire technician service the tires and wheels. If a tire has lost all pressure, take the tire and wheel to a tire shop or your dealer for service. Explosive separation of the tire can cause serious injury.

DO NOT weld to a wheel or rim until the tire is completely removed. Inflated tires can generate a gas mixture with the air than can be ignited by high temperatures from welding procedures performed on the wheel or rim. Removing the air or loosening the tire on the rim (breaking the bead) will NOT eliminate the hazard. This condition can exist whether tires are inflated or deflated. The tire MUST be completely removed from the wheel or rim prior to welding the wheel or rim.

Driving on public roads and general transportation safety

Comply with local laws and regulations.

Use appropriate lighting to meet local regulations.

Make sure SMV emblem is visible.

Lift implements and attachments high enough above ground to prevent accidental contact with road.

When transporting equipment or machine on a transport trailer, make sure it is properly secured. Be sure the SMV emblem on the equipment or machine is covered while being transported on a trailer.

Be aware of overhead structures or power lines and make sure the machine and/or attachments can pass safely under.

Travel speed should be such that complete control and machine stability is maintained at all times.

Slow down and signal before turning.

Pull over to allow faster traffic to pass.

Follow correct towing procedure for equipment with or without brakes.

Fire and explosion prevention

Fuel or oil leaked or spills on hot surfaces or electrical components can cause a fire.

Crop materials, trash, debris, bird nests, or flammable material can ignite on hot surfaces.

Always have a fire extinguisher on or near the machine.

At least once each day and at the end of the day remove all trash and debris from the machine especially around hot components such as engine, transmission, exhaust, battery, etc. More frequent cleaning of your machine may be necessary depending on the operating environment and conditions.

At least once each day, remove debris accumulation around moving components such as bearings, pulleys, belts, gears, cleaning fan, etc. More frequent cleaning of your machine may be necessary depending on the operating environment and conditions.

Inspect the electrical system for loose connections or frayed insulation. Repair or replace loose or damaged parts.

Do not store oily rags or other flammable material on the machine.



SERVICE MANUAL

Engine

WD1904 [- YFG676501]

WD2304 [- YFG676501]

Engine and crankcase - General specification

WD1904	NA
WD2304	NA

Model	WD1904	WD2304
Cylinders	6	6
Aspiration	turbocharged w/ charge air cooler	turbocharged w/ charge air cooler
Bore	104 mm (4.4 in)	104 mm (4.4 in)
Stroke	132 mm (5.0 in)	132 mm (5.0 in)
Displacement	6.7 L (456 cuin)	6.7 L (456 cuin)
Compression	17.5 to 1	17.5 to 1
Firing order	1-5-3-6-2-4	1-5-3-6-2-4
Power	142 kW (190HP)	142 kW (190HP)
Rated RPM	2200 RPM	2200 RPM
Torque at Rated RPM	636 N·m (469 ft-lb)	768 N·m (566 ft-lb)
Torque Rise %	23%	25%
Peak Torque	830N·m (612 ft-lb) @ 1600 RPM	961N·m (709 ft-lb) @ 1600 RPM
Idle Speed	900 RPM	900 RPM
Max. No Load Speed	2250 RPM	2250 RPM

Engine and crankcase - Overview

WD1904
WD2304

NA
NA

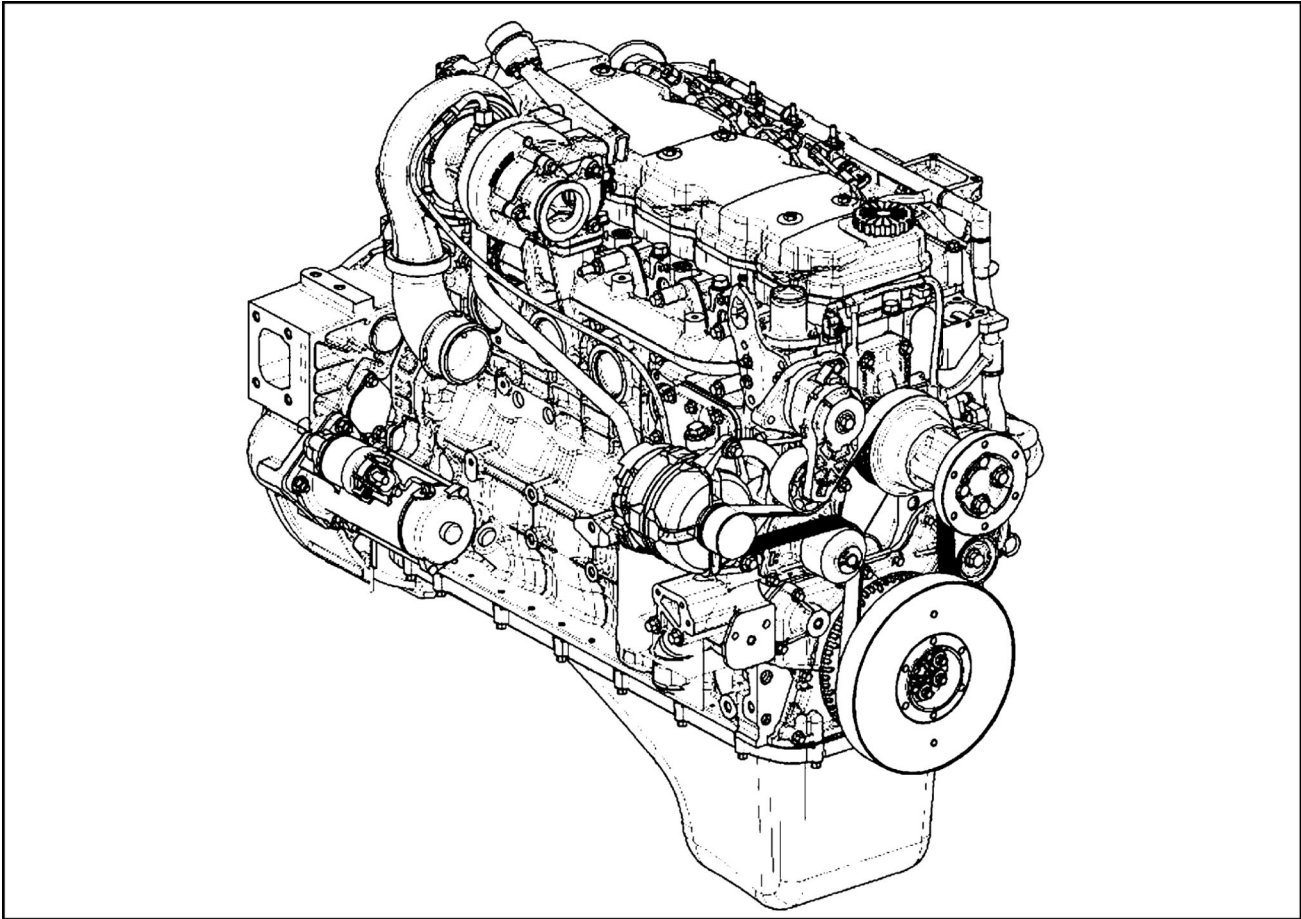

76075199 1

The NEF Tier III engine is a 6-cylinder turbocharged and after cooled unit, having a bore of 104 mm (4.4 in) and a stroke of 132 mm (5.0 in) which generates a displacement of 410 in³.

The engine uses a electronically controlled hi-pressure injection pump and has been designed to meet current emission regulations and must only be serviced by an authorized service agent.

All engines feature cross flow cylinder heads, with the inlet and exhaust manifolds on opposite sides of the cylinder head. The fuel and air combustion process, takes place in the specially designed bowl in the crown of the pistons.

NOTE: The FRONT of the engine is the water pump end. The REAR of the engine is the flywheel end. In this section, right and left correspond to the above when standing at the rear of the engine looking at the flywheel end with the water pump end away from you.

Cylinder block assembly

The cylinder block is an alloy cast iron with deep cylinder skirts, and water jackets for cooling the cylinders. The cylinder bores are machined integral with the cylinder block, during the manufacturing process.

Cylinders are in line and vertical and numbered 1 to 6 from the front (fan end) to the rear of the engine. They can be bored oversize for the fitment of sleeves, which are available in service.

In the following procedures and illustrations the engine is shown removed from the vehicle however there are certain operations that can be performed with the engine installed. Where it is necessary to remove the engine use a suitable hoist or overhead gantry and standard engineering procedures. Removal of the engine is described in Chapter 1 of Section 10 of this manual. Dismantle the engine following conventional techniques and by referring to the appropriate overhaul sections of this chapter. Always refer to the specification section as necessary.

Engine and crankcase - Remove - NEF 6 cylinder

WD1904
WD2304

NA
NA

1. Remove bolt **(2)** on starter to disconnect ground cable and the negative battery cable.
2. Remove battery post nut and disconnect positive battery cable **(3)**.
3. Remove protective cap and disconnect all cables from starter solenoid **(1)**.

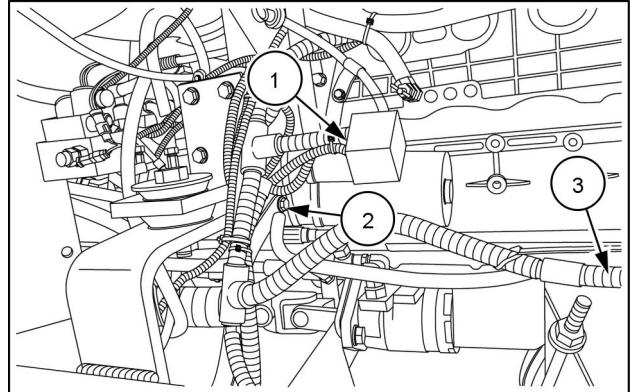

NHIL13WR00112AA 1

4. Disconnect cable and two wires **(1)** from alternator **(2)**. Remove complete wire harness from engine block.

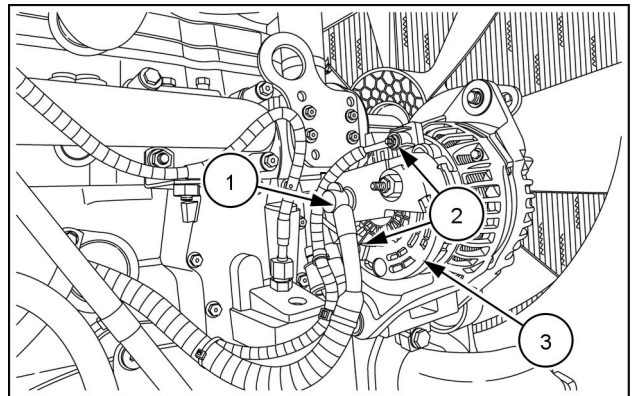

NHIL13WR00108AA 2

5. Drain coolant from radiator and engine by opening valve **(1)**. Catch fluid from drain hose and save for recycling. Remove the radiator cap to speed up the draining, using caution if the system is hot.
6. Disconnect drain hose.

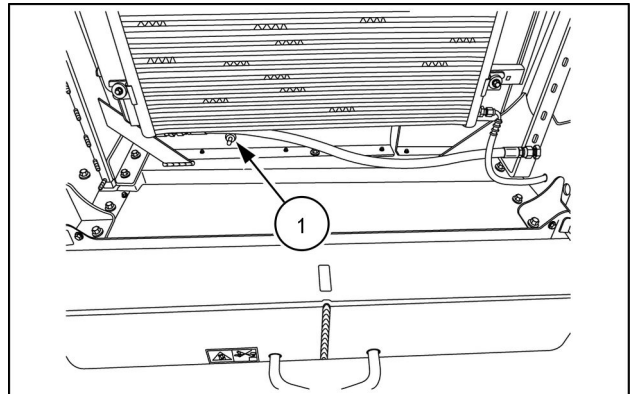

NHIL14WR00316AA 3

7. Remove the spring clamp **(1)** to remove the exhaust pipe elbow **(2)** from the turbocharger.

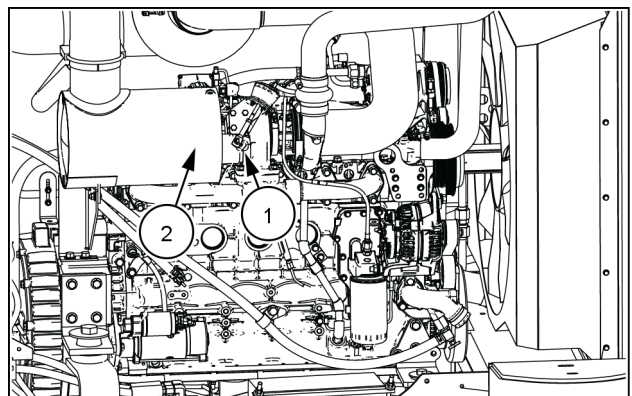

NHIL14WR01245FA 4

8. Using a helper, detach four gas springs (1) from engine area side doors by removing four flange nuts and lock washers.

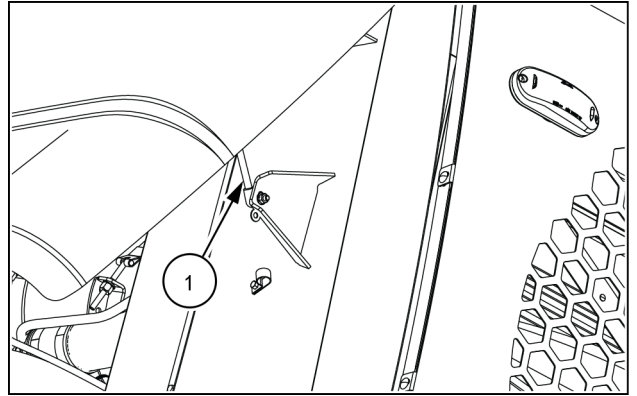

NHIL14WR01151AA 5

9. Remove side doors by removing bolts (1) and lifting doors upward off the support brackets.

NOTICE: Figure 6 shows a top view of the support brackets. Do not stand on top of the engine compartment.

10. Remove four carriage bolts, lock washers and flange nuts (5) that secure the front of the hood.

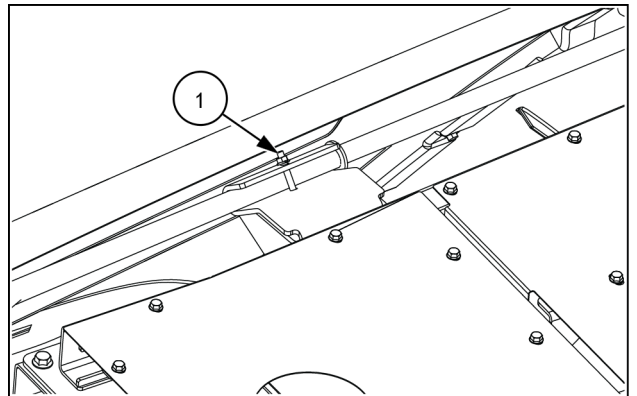

NHIL14WR01152AA 6

11. Loosen the spring clamps (1) and remove tubing from turbo to intercooler (2), and from intercooler to intake manifold (3).

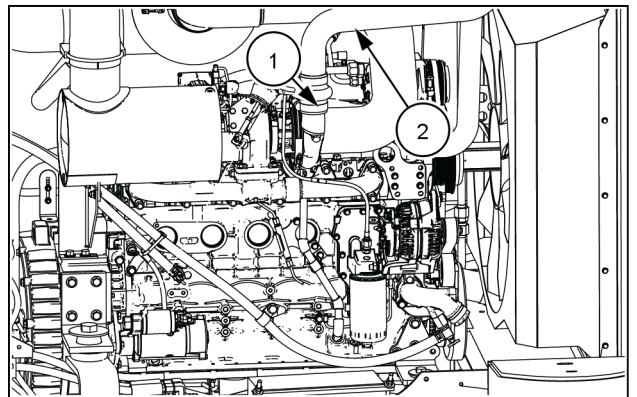

NHIL14WR01245FA 7

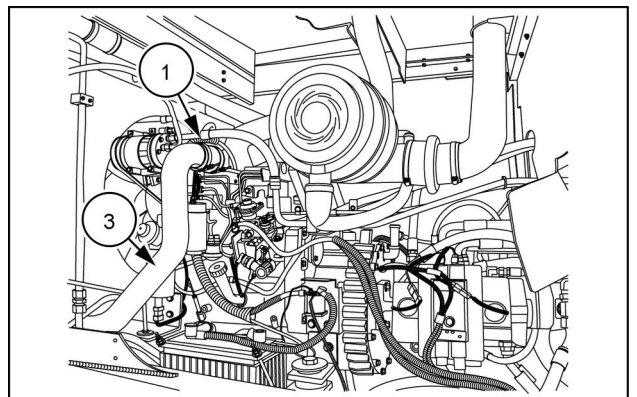

NHIL14WR00360AA 8

12. Disconnect restriction indicator wire from restriction indicator switch (1).
13. Loosen clamps (2) and remove **102 mm (4 in)** diameter tubing (3) from air cleaner.

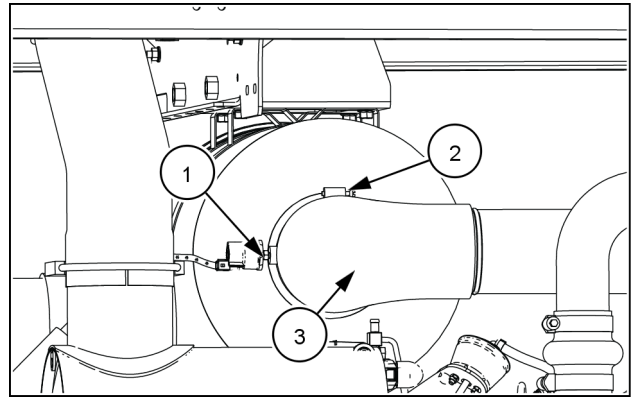

NHIL14WR01246AA 9

14. Tag, label, and disconnect all harnesses (1) that connect the electrical system of the frame of the windrower to the center roof section of the windrower.
15. Remove all cable ties holding the large harness to the center roof section.

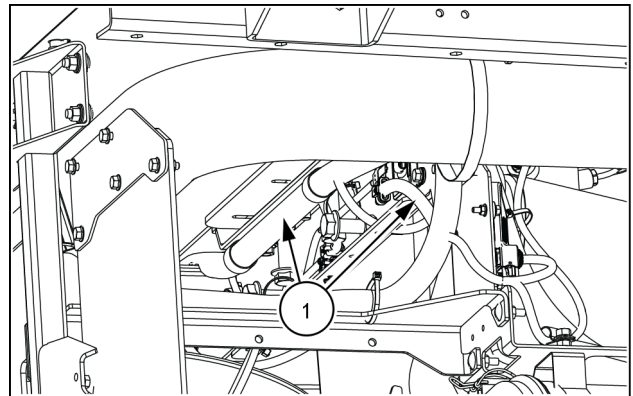

NHIL14WR01149AA 10

16. Remove flange bolts, lock washers and flange nuts (1), to detach hood support frame from radiator side supports and from front upright.
17. Use suitable slings to lift the hood support frame, roof panel, and exhaust after-treatment from the machine.

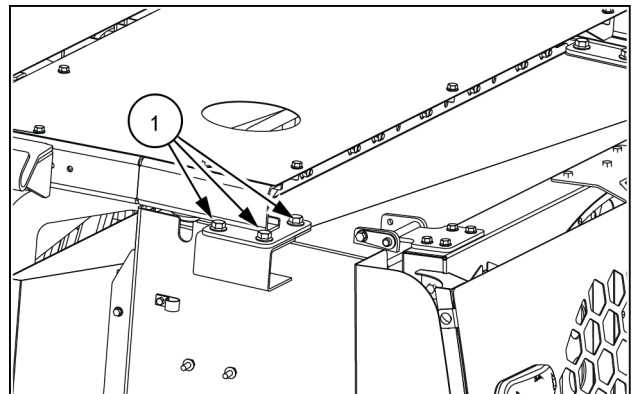

NHIL14WR01146AA 11

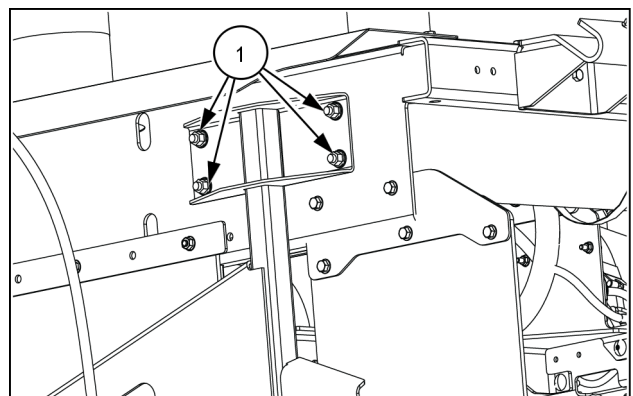

NHIL14WR01147AA 12

NOTICE: Use jackstands to support the hood support frame so that the exhaust and intake components do not get damaged when setting the hood down.

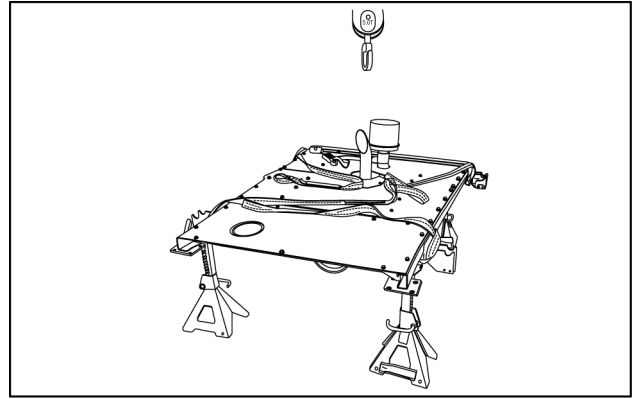

NHIL14WR01124AA 13

18. Disconnect wire connector (1) from the compressor.

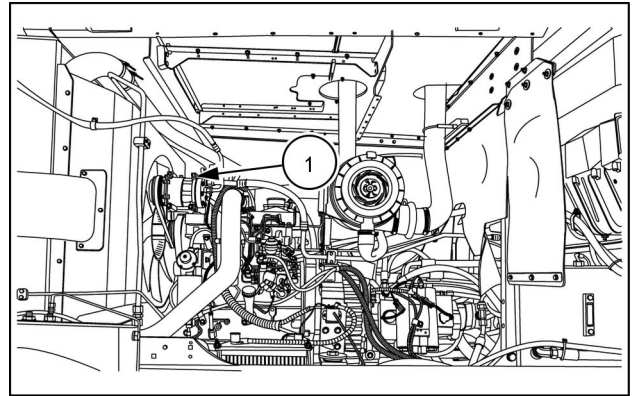

NHIL14WR10359AA 14

19. Disconnect ECM harness (1). Remove ECM harness and A/C compressor harness from the engine.

20. Remove and cap fuel lines (2).

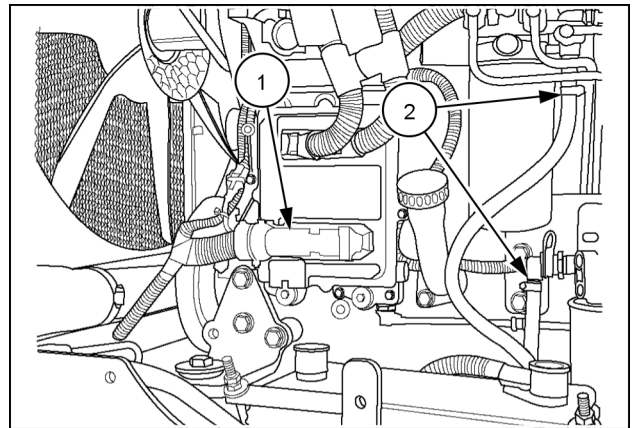

76075209 15

21. Remove and cap both heater hoses (1).

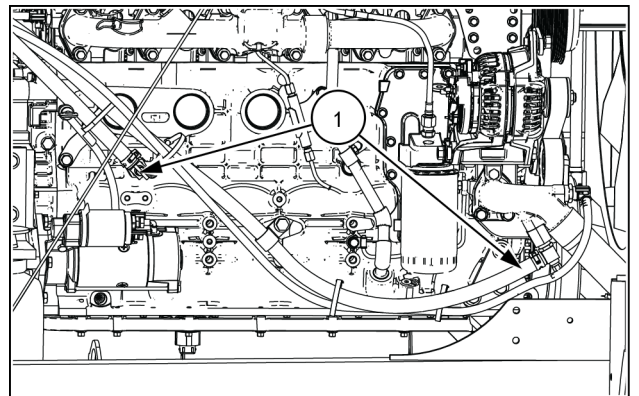

NHIL14WR01150FA 16

22. Remove clamps (1) that secure A/C compressor line (2).
23. Remove flange nuts (3) that secure bracket (4). Set bracket and heater hoses aside.

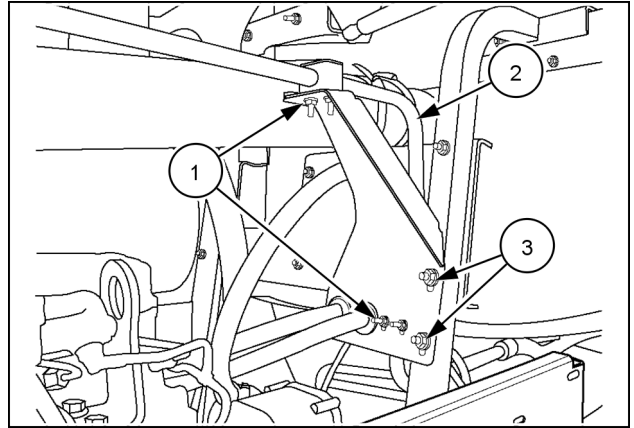

76075210 17

24. Remove air hose (1) that lead to crankcase ventilation filters.

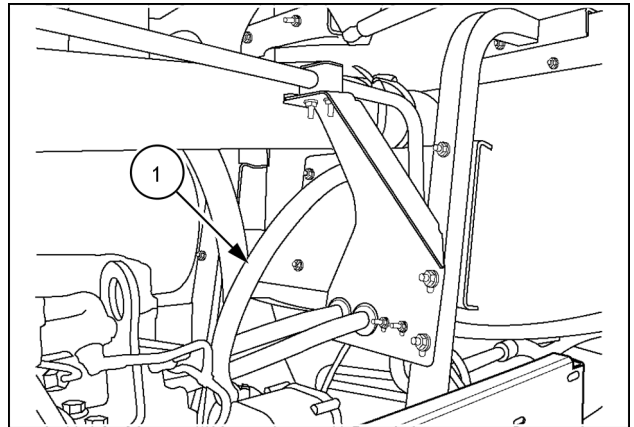

76075210 18

25. Remove A/C compressor drive belt by releasing tension at tensioner (1).

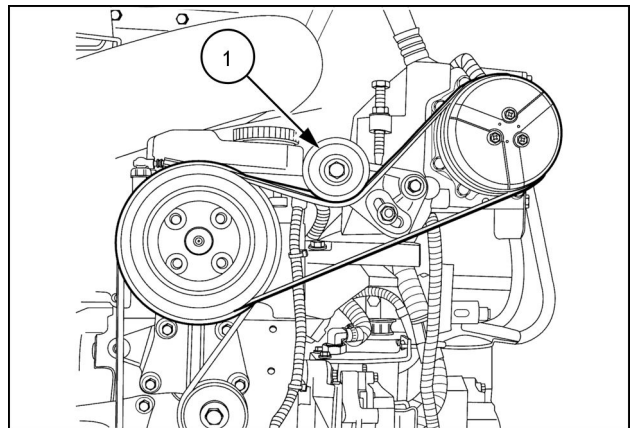

86070777 19

26. Remove three bolts (1) that secure A/C compressor. Hang compressor on right side of machine at (2) with hoses connected.

NOTICE: Use caution when hanging compressor. Do not damage or bend any of the steel fluid lines.

27. If equipped with optional hydraulic pump (1) remove two bolts and lay this pump over to right side.
28. Disconnect wire harness from fuel water switch (2).

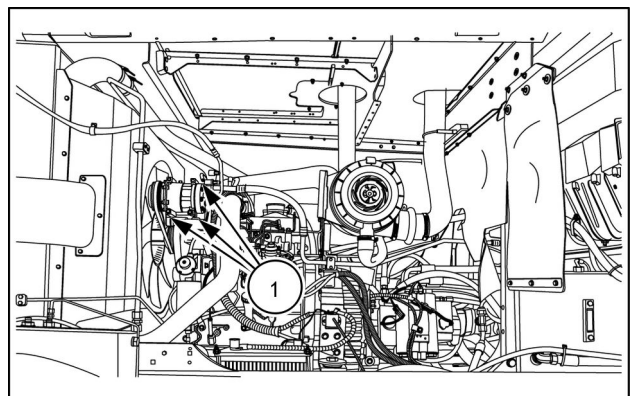

NHIL14WR10359AA 20

29. Disconnect both upper and lower radiator hoses (1).

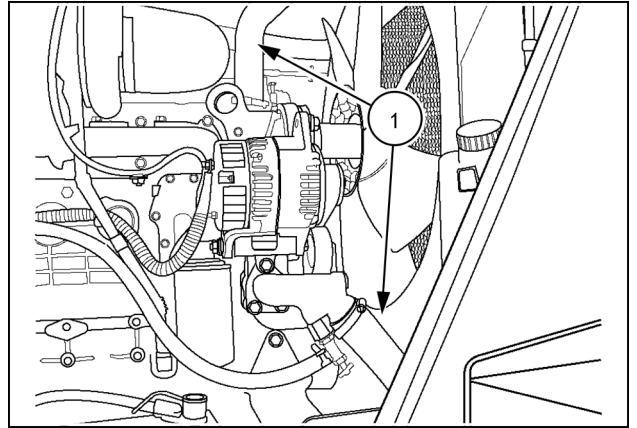

76077320 21

30. Loosen clamp bolts (1) in steering yoke and remove from splined shaft on steering motor.

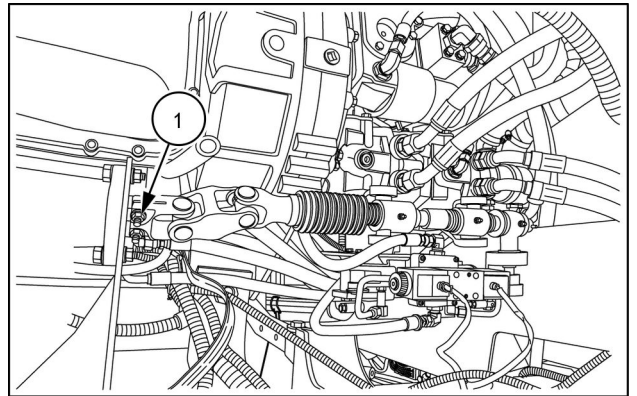

NHIL13WR00104AA 22

31. Remove and cap steel hydraulic lines (1) to the top of transmission. Use a collection pan to catch any excess fluid that may escape. Disconnect breather hose (2).

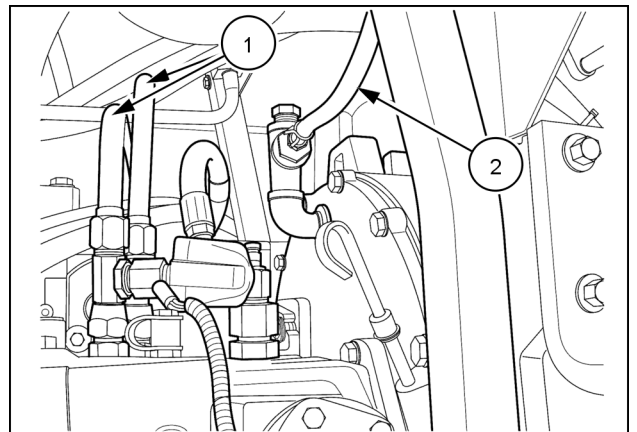

86070789 23

32. Remove plug (1) to drain oil from gear box.
 33. With adequate support provided for the pumps, remove flange bolts (2) that secure the pumps to cover plate (3).
 34. With adequate support provided for the pumps, carefully move transmission and header drive pump away from engine.

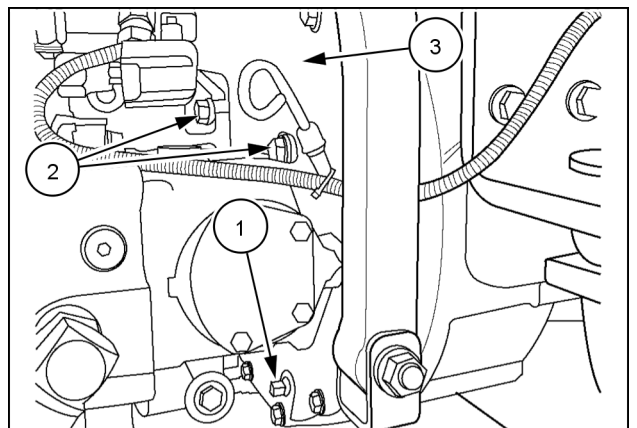

76077321 24

35. Remove four flange screws and lock washers **(1)** from radiator side of fan and detach from drive sheave. Set fan rearward in fan shroud to give maximum clearance to lift out engine.

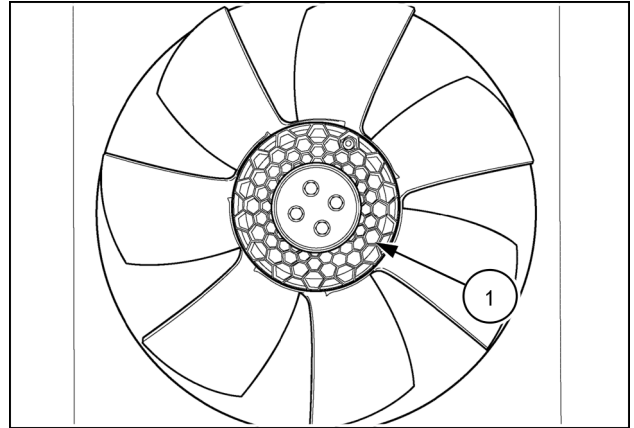

50050774 25

36. Remove four large cap screws with lock nuts **(1)**.
37. Use appropriate lifting equipment to lift engine out of machine.
38. Mount the engine to an engine stand before removing the chain and hoist.

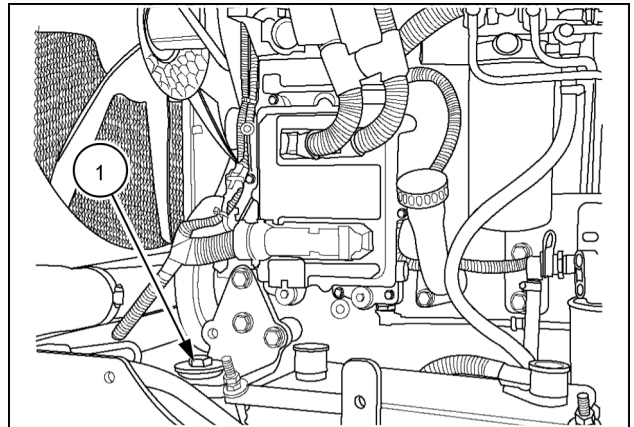

76075209 26

Engine and crankcase - Install - NEF 6 Cylinder

WD1904
WD2304

NA
NA

⚠ WARNING

Heavy parts!
Support designated component(s) with adequate lifting equipment.
Failure to comply could result in death or serious injury.

W1024A

1. Align holes in engine supports and install four 5/8 in. x 3-1/2 in bolts with large washers **(1)** down through engine mounts and install lock nuts. Tighten to **149 N·m (110 lb ft)**

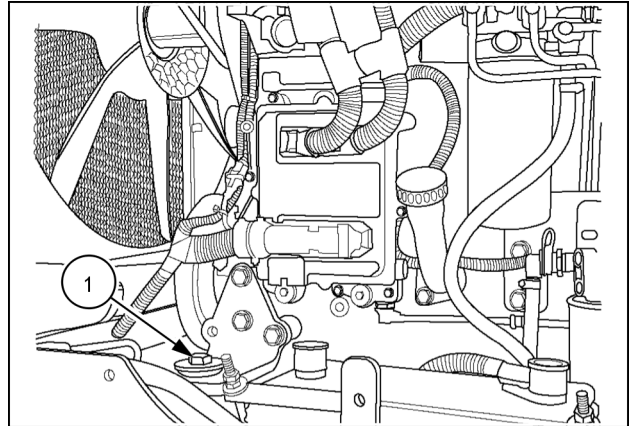

76075209 1

2. Install four flange bolts and lock washers **(1)** from radiator side of fan and attach to drive sheave.

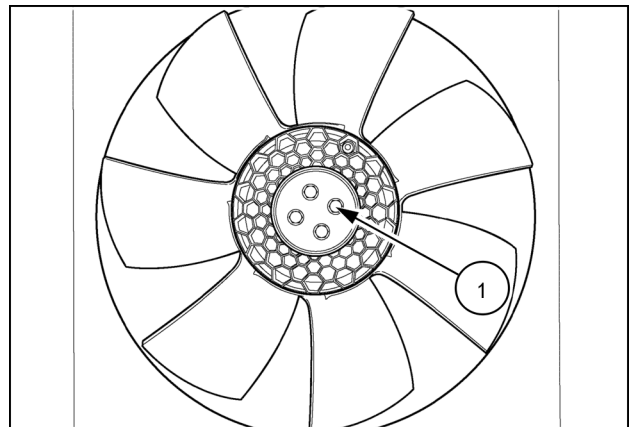

50050774 2

3. With adequate support provided for the pumps, carefully move transmission and header drive pump into mounting position. Install all flange bolts **(1)** that secure the pumps to cover plate **(2)**.

NOTE: Use **LOCTITE® 598™ BLACK** silicon sealant on mating surfaces before joining pumps to cover plate.

4. Install and tighten drain plug **(3)** to cover plate.

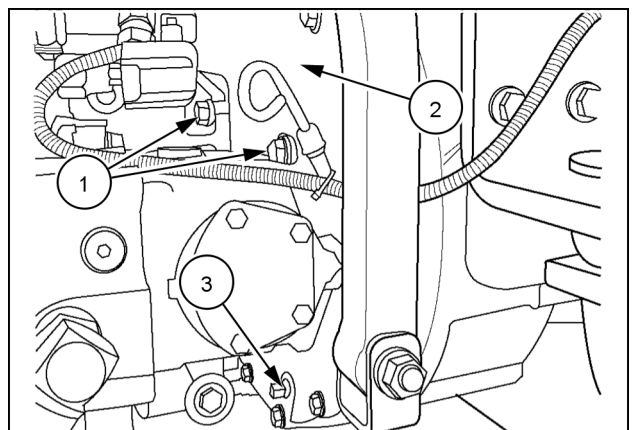

76077321 3

- Fill front gear case section of flywheel housing by removing breather plug (1) with 1.65 l (1.75 US qt) **CASE IH AKCELA GEAR 135 H EP 80W-90** or **CASE IH AKCELA GEAR LUBE SSL 75W90**. Oil level should be between the two marks on the dipstick (2).

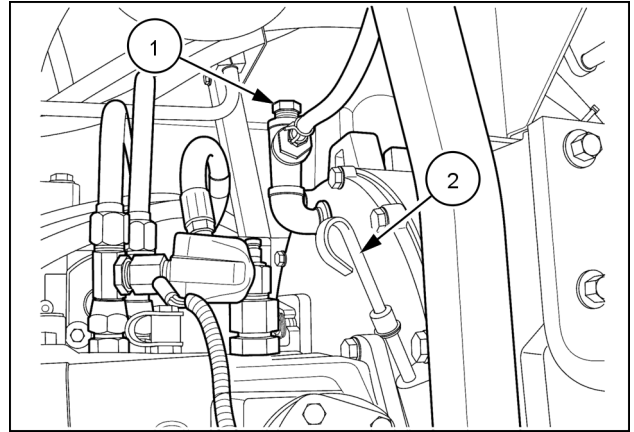

86070789 4

- Replace breather plug, (1).

- Install steel hydraulic lines (1) to the top of transmission. Attach breather hose (2).

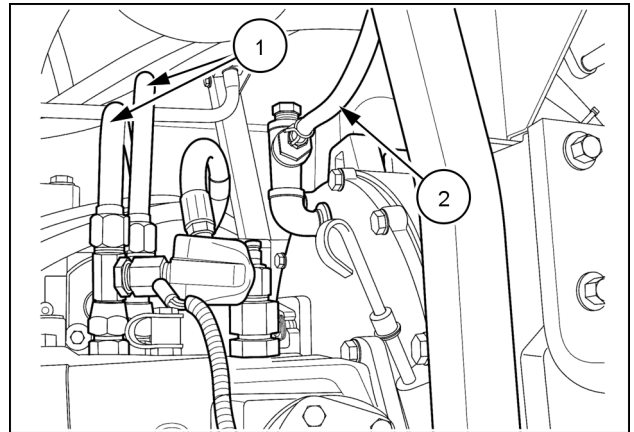

86070789 5

- Attach steering yoke (1) to splined shaft (2). Tighten clamp bolts (3).

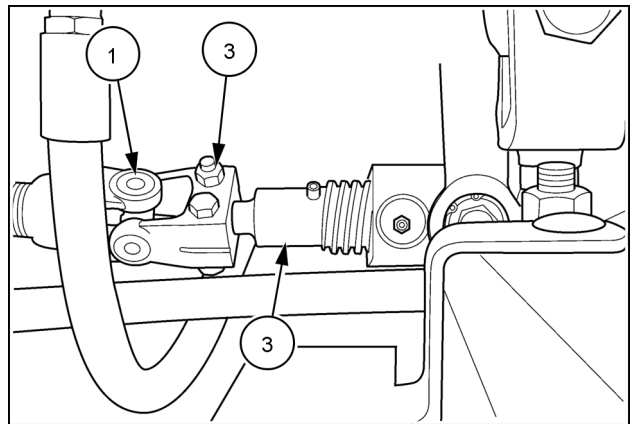

10041124 6

- Connect and tighten both upper and lower radiator hoses (1).

- If equipped with optional hydraulic pump (1) install two 3/8 in. x 1-1/2 in. socket head bolts and lock washers (2) that secure pump.

- Connect wire harness to fuel water switch (3).

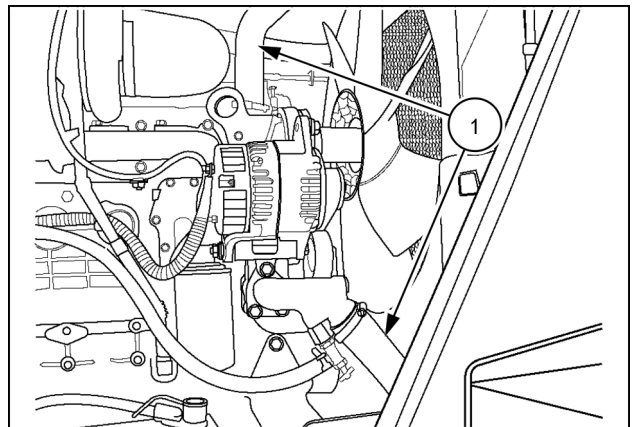

76077320 7



Suggest:

If the above button click is invalid.

Please download this document

first, and then click the above link

to download the complete manual.

Thank you so much for reading

12. Install and tighten 5/16 in. x 4 in. bolts (1) through the base of A/C compressor.

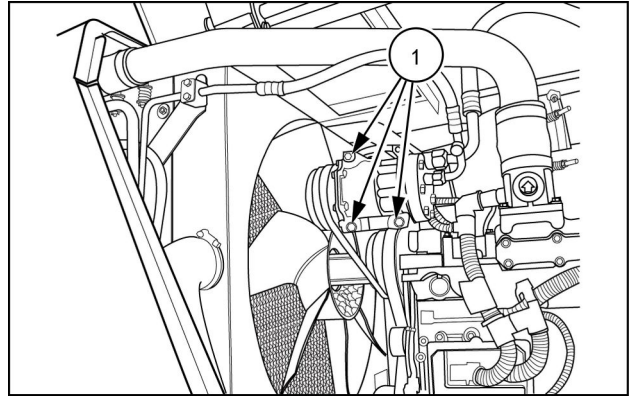

NHILWR00594AA 8

13. Install and adjust A/C compressor drive belt (1) by adjusting tension at tensioner (2).

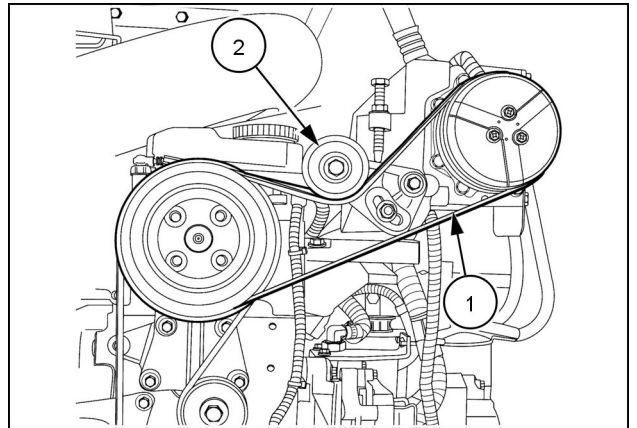

86070777 9

14. Attach air hose (1) that leads to crankcase ventilation filters.

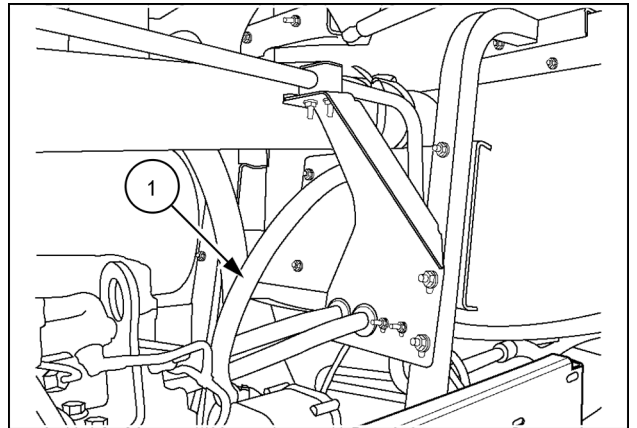

76075210 10

15. Install flange bolts, flange nuts, and lock washers (1) that secure bracket (2). Secure A/C compressor line (3) with clamps (4).

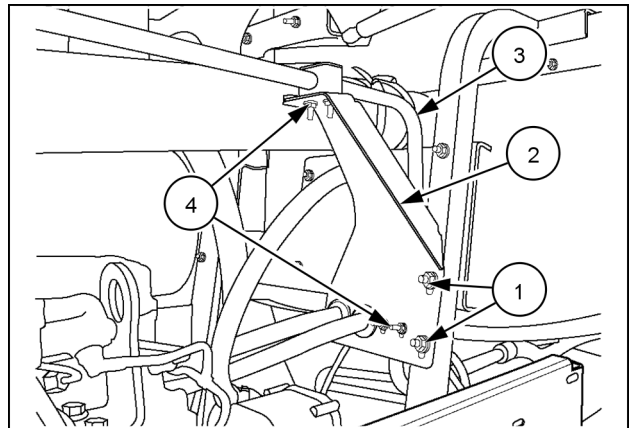

76075210 11

<https://www.ebooklibonline.com>

Hello dear friend!

Thank you very much for reading.

Enter the link into your browser.

The full manual is available for immediate download.

<https://www.ebooklibonline.com>