

WDI204
Tier 3
Self-Propelled Windrower

SERVICE MANUAL

Part number 47904537

1st edition English

July 2015



Link Product / Engine

Product	Market Product	Engine
WD1204 [- YFG676501]	North America	F4GE9484

Contents

INTRODUCTION

Engine	10
[10.001] Engine and crankcase	10.1
[10.202] Air cleaners and lines	10.2
[10.206] Fuel filters	10.3
[10.216] Fuel tanks	10.4
[10.218] Fuel injection system.....	10.5
[10.250] Turbocharger and lines.....	10.6
[10.254] Intake and exhaust manifolds and muffler	10.7
[10.400] Engine cooling system	10.8
[10.414] Fan and drive	10.9
Front axle system	25
[25.310] Final drives	25.1
Rear axle system	27
[27.550] Non-powered rear axle.....	27.1
Hydrostatic drive	29
[29.100] Transmission and steering hydrostatic control	29.1
[29.202] Hydrostatic transmission	29.2
[29.218] Pump and motor components.....	29.3
Brakes and controls	33
[33.110] Parking brake or parking lock	33.1
Hydraulic systems	35
[35.000] Hydraulic systems.....	35.1
[35.100] Main lift system.....	35.2
[35.105] Charge pump.....	35.3
[35.220] Auxiliary hydraulic pump and lines	35.4

<https://www.ebooklibonline.com>

Hello dear friend!

Thank you very much for reading.

Enter the link into your browser.

The full manual is available for immediate download.

<https://www.ebooklibonline.com>

[35.300] Reservoir, cooler, and filters.....	35.5
[35.304] Combination pump units	35.6
[35.410] Header or attachment height system	35.7
[35.415] Header or attachment tilting system	35.8
[35.760] Header reverser drive	35.9
[35.910] Head and header hydraulic drive	35.10
Steering.....	41
[41.101] Steering control	41.1
Cab climate control	50
[50.200] Air conditioning	50.1
Electrical systems	55
[55.000] Electrical system	55.1
[55.019] Hydrostatic drive control system	55.2
[55.050] Heating, Ventilation, and Air-Conditioning (HVAC) control system.....	55.3
[55.100] Harnesses and connectors.....	55.4
[55.640] Electronic modules.....	55.5
[55.DTC] FAULT CODES.....	55.6
Platform, cab, bodywork, and decals	90
[90.124] Pneumatically-adjusted operator seat.....	90.1
[90.150] Cab.....	90.2
[90.151] Cab interior.....	90.3
[90.154] Cab doors and hatches	90.4



INTRODUCTION

Safety rules

WD1204

NA

Personal safety





This is the safety alert symbol. It is used to alert you to potential personal injury hazards. Obey all safety messages that follow this symbol to avoid possible death or injury.

Throughout this manual you will find the signal words DANGER, WARNING, and CAUTION followed by special instructions. These precautions are intended for the personal safety of you and those working with you.

Read and understand all the safety messages in this manual before you operate or service the machine.

 DANGER indicates a hazardous situation that, if not avoided, will result in death or serious injury.

 WARNING indicates a hazardous situation that, if not avoided, could result in death or serious injury.

 CAUTION indicates a hazardous situation that, if not avoided, could result in minor or moderate injury.

FAILURE TO FOLLOW DANGER, WARNING, AND CAUTION MESSAGES COULD RESULT IN DEATH OR SERIOUS INJURY.

Machine safety

NOTICE: Notice indicates a situation that, if not avoided, could result in machine or property damage.

Throughout this manual you will find the signal word Notice followed by special instructions to prevent machine or property damage. The word Notice is used to address practices not related to personal safety.

Information

NOTE: Note indicates additional information that clarifies steps, procedures, or other information in this manual.

Throughout this manual you will find the word Note followed by additional information about a step, procedure, or other information in the manual. The word Note is not intended to address personal safety or property damage.

Safety rules

WD1204

NA

General safety rules

Use caution when operating the machine on slopes. Raised equipment, full tanks and other loads will change the center of gravity of the machine. The machine can tip or roll over when near ditches and embankments or uneven surfaces.

- Only skilled operators who are familiar with all the controls and harvesting techniques should use the equipment. It is recommended to operate on cultivated land with slopes no greater than **26 % (15 °)** uphill and downhill.
- If necessary, when driving downhill change into a lower gear before starting the descent. Machine must be stopped to downshift into a lower gear.

Never permit anyone other than the operator to ride on the machine.

Never operate the machine under the influence of alcohol, drugs, or while otherwise impaired.

Pay attention to overhead power lines and hanging obstacles. High voltage lines may require significant clearance for safety.

Hydraulic oil or diesel fuel leaking under pressure can penetrate the skin, causing serious injury or infection.

- DO NOT use your hand to check for leaks. Use a piece of cardboard or paper.
- Stop engine, remove key and relieve the pressure before connecting or disconnecting fluid lines.
- Make sure all components are in good condition and tighten all connections before starting the engine or pressurizing the system.
- If hydraulic fluid or diesel fuel penetrates the skin, seek medical attention immediately.
- Continuous long term contact with hydraulic fluid may cause skin cancer. Avoid long term contact and wash the skin promptly with soap and water.

Keep clear of moving parts. Loose clothing, jewelry, watches, long hair, and other loose or hanging items can become entangled in moving parts.

Wear protective equipment when appropriate.

DO NOT attempt to remove material from any part of the machine while it is being operated or components are in motion.

Make sure all guards and shields are in good condition and properly installed before operating the machine. Never operate the machine with shields removed. Always close access doors or panels before operating the machine.

Dirty or slippery steps, ladders, walkways, and platforms can cause falls. Make sure these surfaces remain clean and clear of debris.

A person or pet within the operating area of a machine can be struck or crushed by the machine or its equipment. DO NOT allow anyone to enter the work area.

Raised equipment and/or loads can fall unexpectedly and crush persons underneath. Never allow anyone to enter the area underneath raised equipment during operation.

Never operate engine in enclosed spaces as harmful exhaust gases may build up.

Before starting the machine, be sure that all controls are in neutral or park lock position.

Start the engine only from the operator's seat. If the safety start switch is bypassed, the engine can start with the transmission in gear. Do not connect or short across terminals on the starter solenoid. Attach jumper cables as described in the manual. Starting in gear may cause death or serious injury.

Always keep windows, mirrors, all lighting, and Slow Moving Vehicle (SMV) emblem clean to provide the best possible visibility while operating the machine.

Operate controls only when seated in the operator's seat, except for those controls expressly intended for use from other locations.

Before leaving the machine:

1. Park machine on a firm level surface.
2. Put all controls in neutral or park lock position.
3. Engage park brake, use wheel chocks if required.
4. Lower all hydraulic equipment — Implements, header, etc.
5. Turn off engine and remove key.

When, due to exceptional circumstances, you would decide to keep the engine running after leaving the operator's station, then the following precautions must be followed:

1. Bring the engine to low idle speed.
2. Disengage all drive systems.

3. **⚠ WARNING**

**Some components may continue to run down after disengaging drive systems.
Make sure all drive systems are fully disengaged.
Failure to comply could result in death or serious injury.**

W0113A

Shift the transmission into neutral.

4. Apply the parking brake.

⚠ General maintenance safety ⚠

Keep area used for servicing the machine clean and dry. Clean up spilled fluids.

Service machine on a firm level surface.

Install guards and shields after servicing the machine.

Close all access doors and install all panels after servicing the machine.

Do not attempt to clean, lubricate, clear obstructions or make adjustments to the machine while it is in motion or while the engine is running.

Always make sure working area is clear of tools, parts, other persons and pets before you start operating the machine.

Unsupported hydraulic cylinders can lose pressure and drop the equipment causing a crushing hazard. Do not leave equipment in a raised position while parked or during service, unless securely supported.

Jack or lift the machine only at jack or lift points indicated in this manual.

Incorrect towing procedures can cause accidents. When towing a disabled machine follow the procedure in this manual. Use only rigid tow bars.

Stop the engine, remove key and relieve pressure before disconnecting or connecting fluid lines.

Stop the engine and remove key before disconnecting or connecting electrical connections.

Scalding can result from incorrect removal of coolant caps. Cooling system operates under pressure. Hot coolant can spray out if a cap is removed while the system is hot. Allow system to cool before removing cap. When removing a cap turn it slowly to allow pressure to escape before completely removing the cap.

Replace damaged or worn tubes, hoses, electrical wiring, etc.

Engine, transmission, exhaust components, and hydraulic lines may become hot during operation. Take care when servicing such components. Allow surfaces to cool before handling or disconnecting hot components. Wear protective equipment when appropriate.



SERVICE MANUAL

Engine

.....WD1204 [- YFG676501]

Engine and crankcase - Overview

WD1204

NA

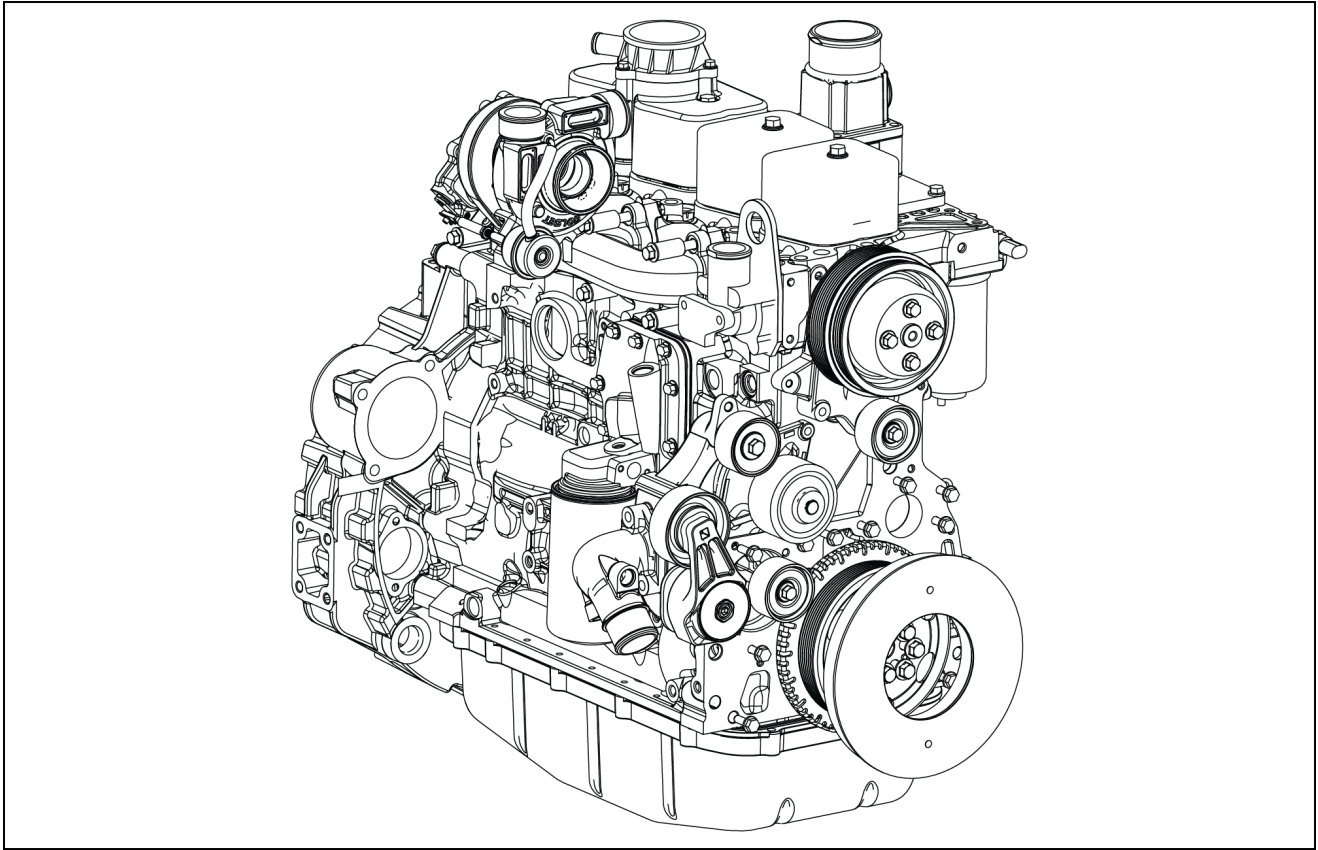

NHIL14WR01174HA 1

The NEF Tier III engine is a 4-cylinder turbocharged and after cooled unit, having a bore of 104 mm (4.1 in) and a stroke of 132 mm (5.2 in) which generates a displacement of 4.5 L (275 in³) .

The engine uses a electronically controlled hi-pressure injection pump and has been designed to meet current emission regulations and must only be serviced by an authorized service agent.

All engines feareure cross flow cylinder heads, with the inlet and exhaust manifolds on opposite sides of the cylinder head. The fuel and air combustion process, takes place in the specially designed bowl in the crown of the pistons.

NOTE: The FRONT of the engine is the water pump end. The REAR of the engine is the flywheel end. In this section, right and left correspond to the above when standing at the rear of the engine looking at the flywheel end with the water pump end away from you.

Cylinder block assembly

The cylinder block is an alloy cast iron with deep cylinder skirts, and water jackets for cooling the cylinders. The cylinder bores are machined integral with the cylinder block, during the manufacturing process.

Cylinders are in line and vertical and numbered 1 to 4 from the front (fan end) to the rear of the engine. They can be bored oversize for the fitment of sleeves, which are available in service.

In the following procedures and illustrations the engine is shown removed from the vehicle however there are certain operations that can be performed with the engine installed. Where it is necessary to remove the engine use a suitable hoist or overhead gantry and standard engineering procedures. Removal of the engine is described in Chapter 1 of Section 10 of this manual. Dismantle the engine following conventional techniques and by referring to the appropriate overhaul sections of this chapter. Always refer to the specification section as necessary.

NOTE: Where it is necessary to remove additional items to gain access to the components on the engine refer to Engine Removal.

Engine and crankcase - Drain fluid

WD1204

NA

1. Warm the engine to operating temperature. Park the windrower on a level surface centering the steering wheel, set the park brake and stop the engine.

NOTICE: Clean the area around each check plug, fill cap, dipstick, etc. before removal. Failure to clean these areas may allow contamination to enter the system.

2. Remove engine oil drain plug (1) and catch the oil in a suitable container.
3. Replace the drain plug after the oil has been drained.

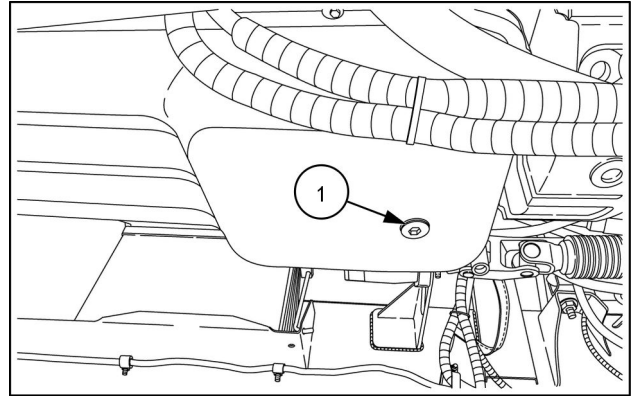

NHIL13WR00114AA 1

4. Clean the oil filter area. Unscrew and discard the oil filter (1).

NOTE: Always discard used oil and filters properly.

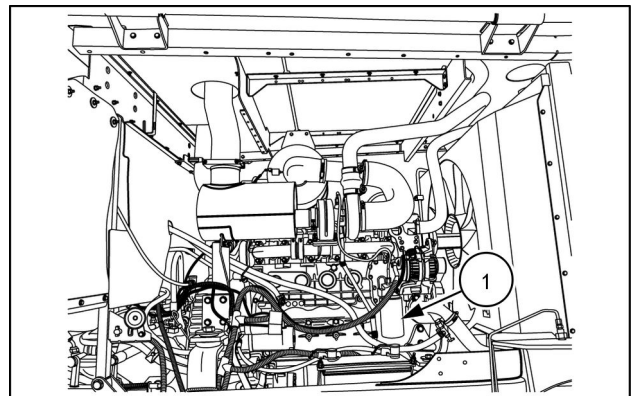

NHIL14WR00356AA 2

Engine and crankcase - Filling

WD1204

NA

Refer to the Operators Manual for information on the oil to use and the oil change interval.

1. Make sure that the drain plug (1) is installed on the bottom of the oil pan.
2. Apply a thin film of clean oil around the rubber seal of the new oil filter. Screw the new filter onto the filter head until the rubber seal contacts the mounting surface, then tighten an additional 3/4 to 1 full turn. Do not overtighten.

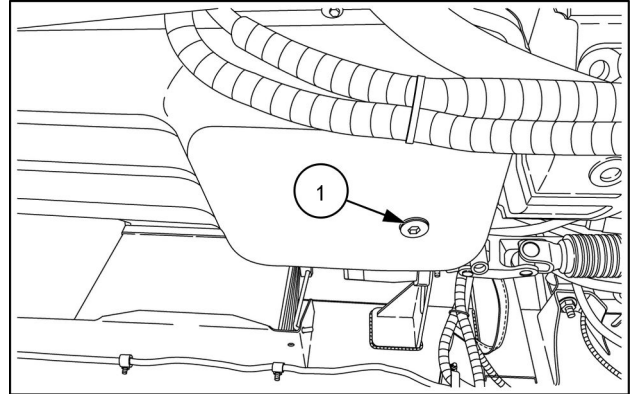

NHIL13WR00114AA 1

3. Clean any debris from around the crankcase fill cap.
4. Remove the filler cap (1) and fill the engine with approximately 16 l (16.9 US qt) of fresh oil, adhering to the correct grade and viscosity oil.
5. Start and run the engine at idle speed for approximately one minute to circulate the oil, then stop the engine.

NOTICE: Verify the engine oil pressure is in the operating range at start up. If it is not, stop the engine and investigate the cause, or serious engine damage will result.

6. Check the drain plug and oil filter areas for leaks.
7. Wait five minutes, to allow the oil to drain into the oil pan, and recheck the oil level on the dipstick. The oil level should be between the two notches.
8. If required, add more oil to obtain the correct level.

NOTICE: Do not operate engine with the oil level below the lower notch on the dipstick. Damage to the engine may occur.

NOTICE: The use of B20 fuel requires checking the engine oil daily. If the oil level increases, contact your dealer.

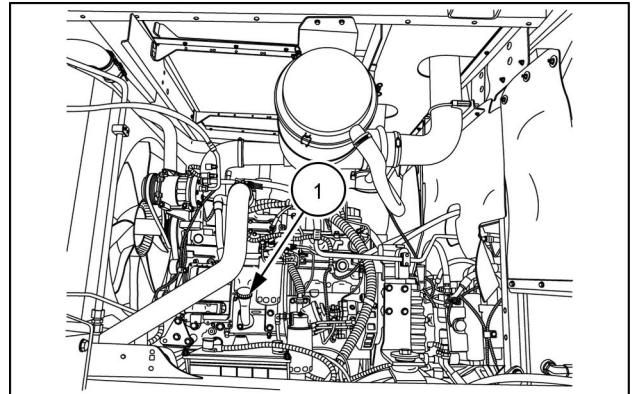

NHIL14WR00357AA 2

Engine and crankcase - Check - Oil level

WD1204

NA

NOTE: Before checking the engine oil level, park the windrower on a level surface, stop the engine, set the park brake, and wait for a short period (minimum 5 minutes) to allow the oil to drain back into the oil pan.

1. Clean the dipstick area of debris and remove dipstick **(1)** wipe it clean, and reinsert it fully.
2. Pull the dipstick out again and check the oil level. The oil level should be at the top of the flattened area.

NOTICE: Do not operate the engine with the oil level below the "lower" mark on the dipstick. Damage to the engine may occur.

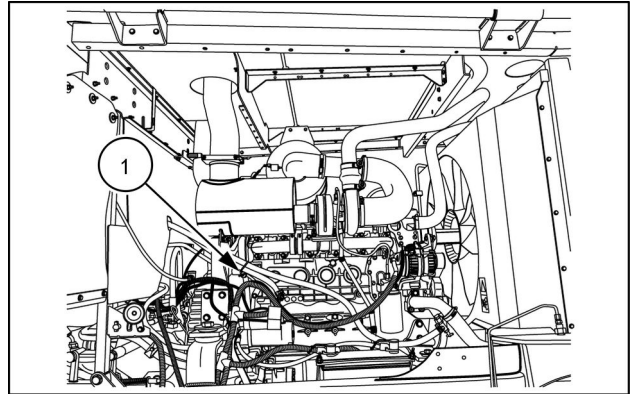

NHIL14WR00356AA 1

Adding engine oil

1. Clean any debris from around the crankcase fill cap **(1)** on the left side of the windrower.
2. Remove the fill cap **(1)** and add oil as required so the level is within the two marks on the dipstick. The quantity of oil represented by the upper and lower marks is approximately **2 l (2.1 US qt)**.
3. Install the fill cap and check the dipstick.

NOTICE: Do not operate the engine with the oil level above the "upper" mark. The excess oil will be burned off or pushed out the crankcase breather and give a false impression of oil consumption.

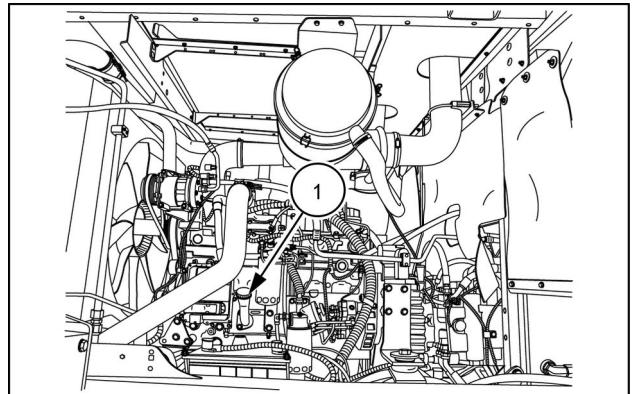

NHIL14WR00357AA 2

Engine and crankcase - Remove - NEF 4 Cylinder

WD1204

NA

1. Drain coolant from radiator and engine by opening valve **(1)**. Catch fluid from drain hose in a clean container and save for recycling. Remove the radiator cap to speed up the draining, using caution if the system is hot.

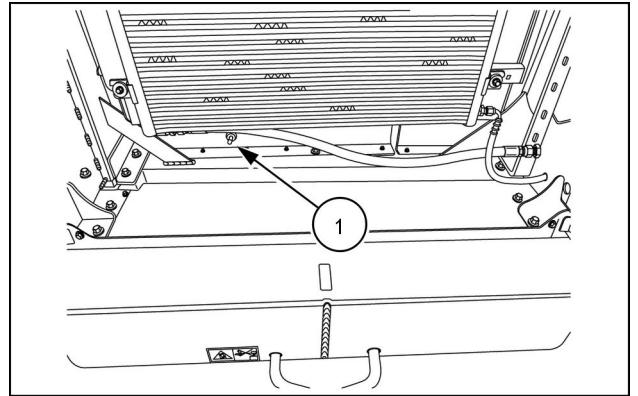

NHIL14WR00316AA 1

2. Remove battery ground cables by removing starter mounting bolt **(1)**.
3. Remove all positive power cables from starter terminal **(2)**.
4. Remove wire **(3)** from starter terminal.
5. Open valve **(4)** if closed, and allow any trapped coolant to drain. Loosen clamp **(5)** and remove heater hose.

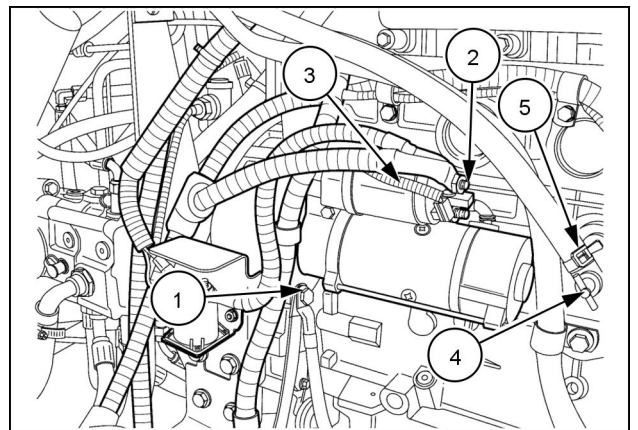

86070630 2

6. Loosen clamp **(1)** and remove lower radiator hose. Also, in like manner, disconnect the upper hose.

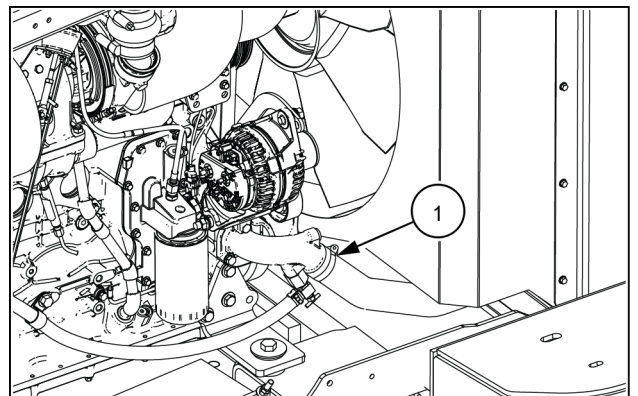

NHIL14WR01244AA 3

7. Using a helper, detach four gas springs **(1)** from engine area side doors by removing four flange nuts and lock washers.

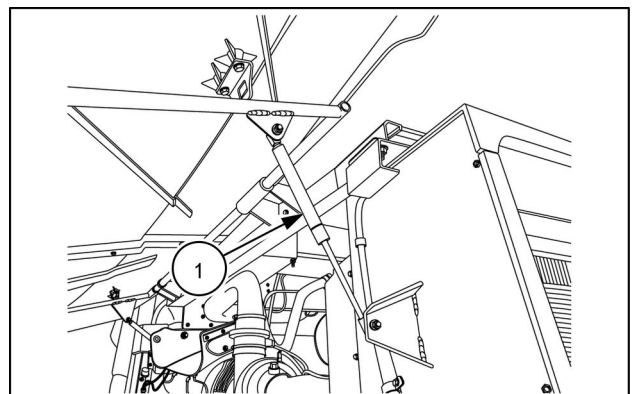

NHIL14WR01126AA 4

8. Remove side doors by removing one bolt (1) and lifting doors upward off the support brackets

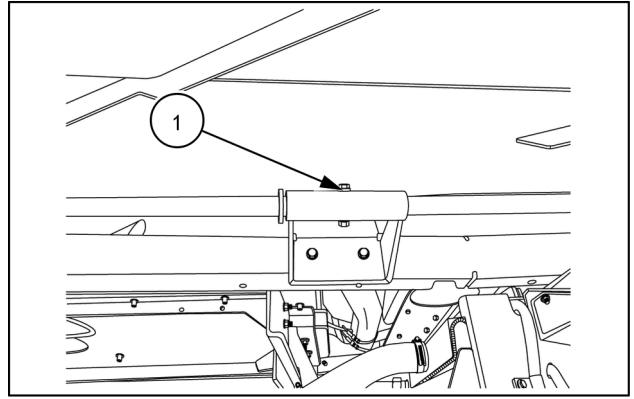

NHIL14WR01127AA 5

9. Loosen the spring clamps (1) and remove tubing from turbo to intercooler, and from intercooler to intake manifold.
10. Push off clip and remove fuel return hose with elbow attached. Likewise push off clip on fuel supply hose. Plug and bag the end of these hoses to keep out contamination.
11. Disconnect harness from fuel injection pump.
12. Remove spring clamp (2) from turbocharger and disconnect the exhaust (3) from the turbocharger.

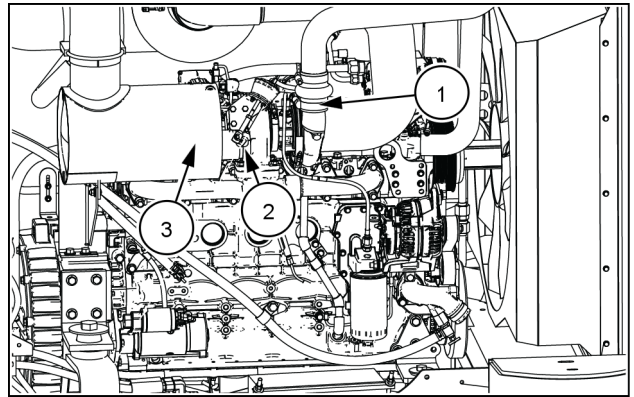

NHIL14WR01245FA 6

13. Disconnect restriction indicator wire from restriction indicator switch (1).
14. Loosen clamps (2) and remove 102 mm (4 in) diameter tubing (3) from air cleaner.

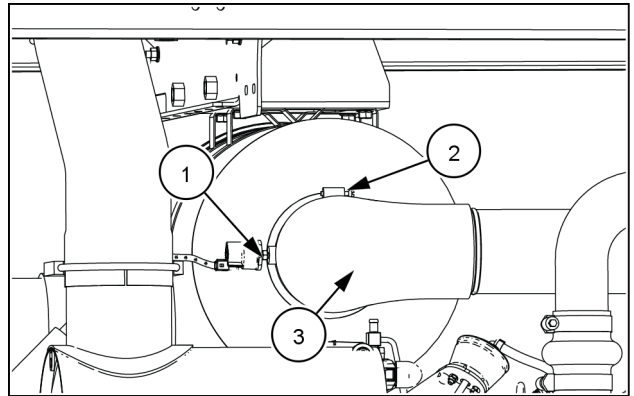

NHIL14WR01246AA 7

15. Tag, label, and disconnect all harnesses (1) that connect the electrical system of the frame of the windrower to the center roof section of the windrower.
16. Remove all cable ties (2) holding the large harness to the center roof section.

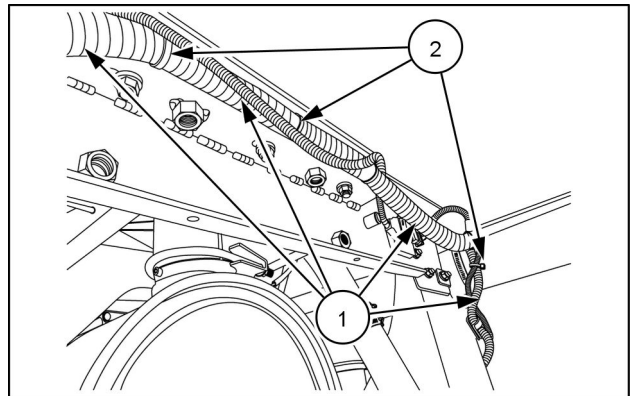

NHIL14WR01120AA 8

17. Remove flange bolts, lock washers and flange nuts (1), to detach hood support frame from radiator side supports and from front upright.
18. Use suitable slings to lift the hood support frame, roof panel, and exhaust after-treatment from the machine.

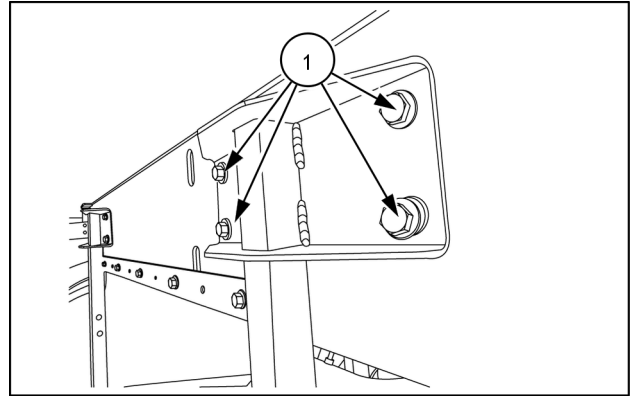

NHIL14WR01122AA 9

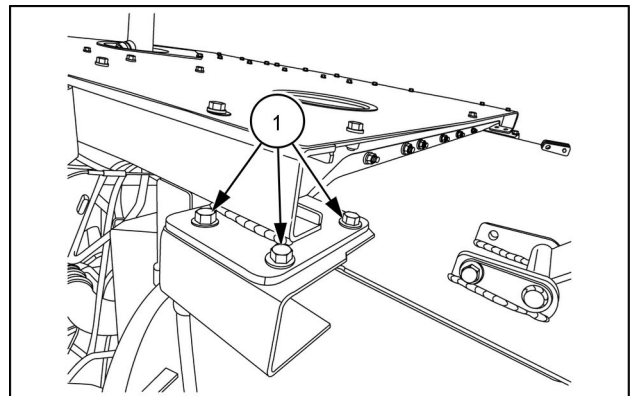

NHIL14WR01121AA 10

NOTICE: Use jackstands to support the hood support frame so that the exhaust and intake components do not get damaged when setting the hood down.

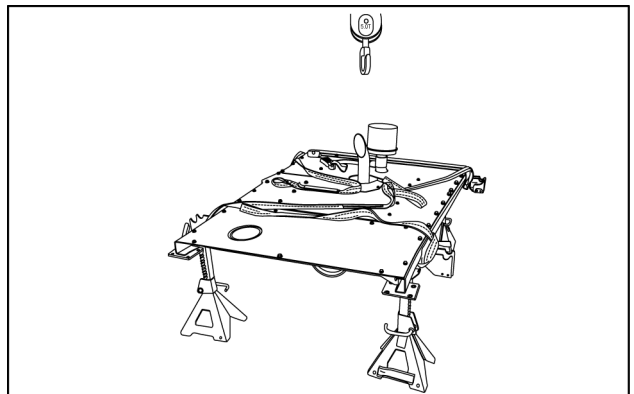

NHIL14WR01124AA 11

19. Disconnect wire harness at both sides of intake air heater (1) if so equipped, and at oil pressure switch (2).

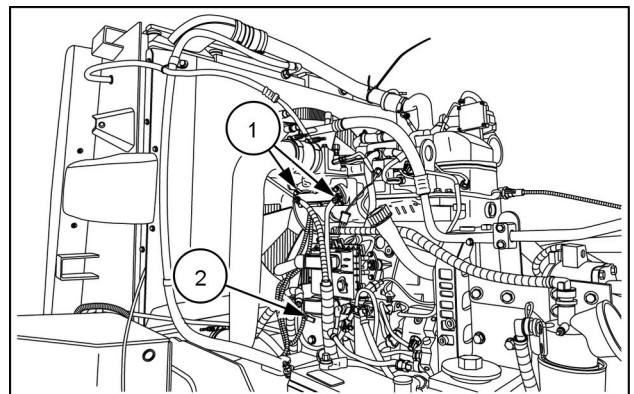

NHIL14WR01123AA 12

20. Disconnect wire connector **(1)** from the compressor.

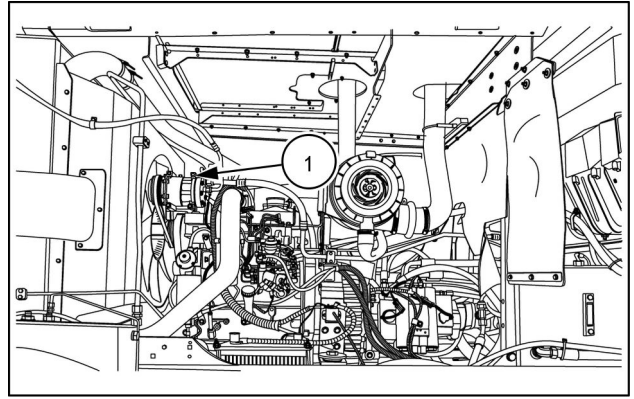

NHIL14WR10359AA 13

21. Disconnect temperature sensor **(1)**.

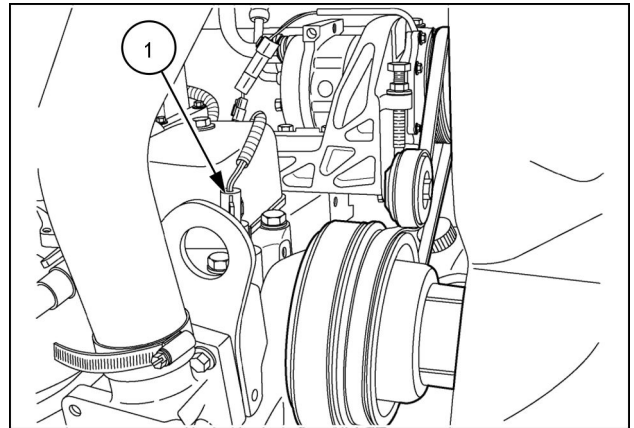

86075189 14

22. Remove three 5/16 x 3-3/4 cap screws with lock washers and flange nuts **(1)** from holes in compressor and through lower mount casting.
23. Remove drive belt and lay compressor over to right side of machine with hoses connected.

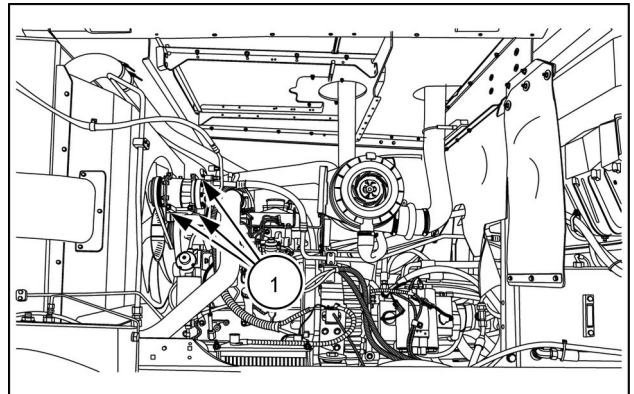

NHIL14WR10359AA 15

24. If equipped with auxiliary pump, remove two hex head flange bolts and lock washers **(1)** to remove pump with PTO drive and hoses attached. Lay over to right side of windrower frame. Save gasket for re-use when reinstalling.

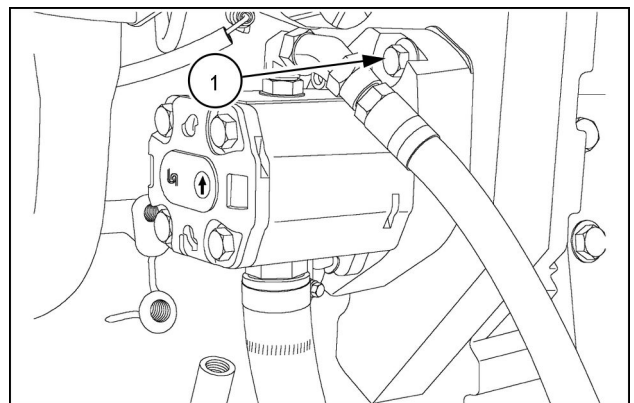

40044943N 16

25. Disconnect cable (1) and two wires of harness (2) from alternator by removing three nuts. Screw these nuts on the terminals loosely to save for later use.
26. Remove and loosen clamps as necessary to free wiring harness and cables from engine.

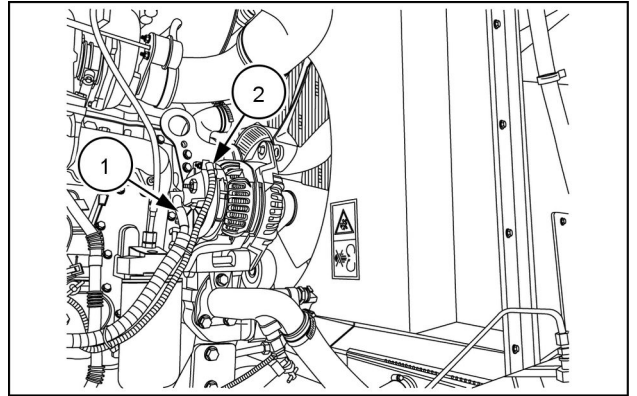

NHIL14WR01129AA 17

27. Remove plug (1) to drain oil from gear box.
28. With adequate support provided for the pumps, remove twelve flange bolts (2).

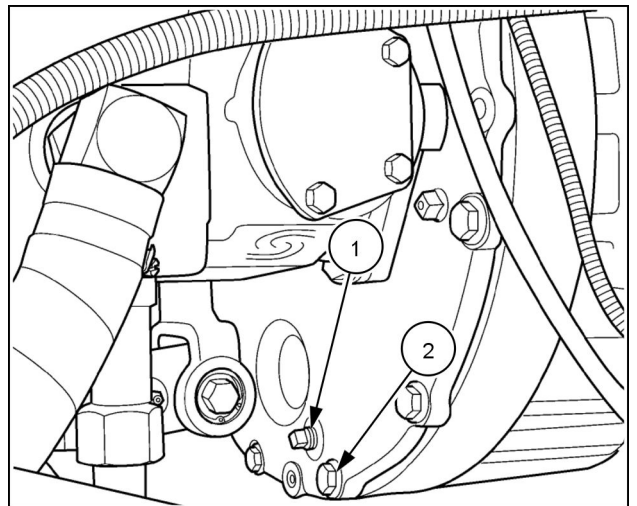

76113149 18

29. There are three tapped holes (1) in periphery of cover plate that are provided for removal purposes. Use three of the bolts removed in previous step and thread into tapped holes to push plate away from flywheel housing.

NOTICE: The holes are tapped with M10 x 1.5 threads. Do not attempt to use inch series bolts, as thread damage will occur.

30. Pull cover plate with pumps attached forward so that drive gears clear the flywheel housing. Support from above to avoid damage to hoses and fittings.

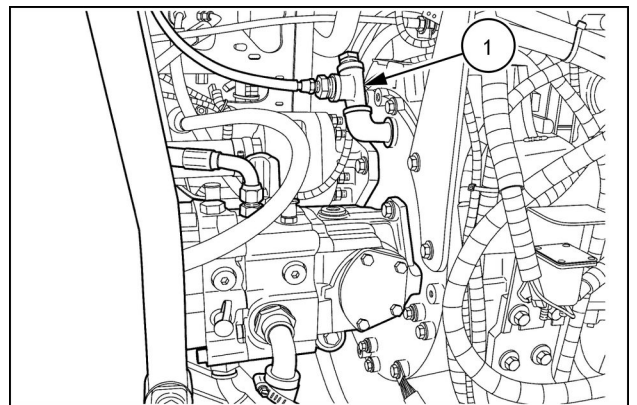

86070787N 19

31. It may be necessary to loosen clamp bolts (1) in steering yoke and remove from splined shaft (2).

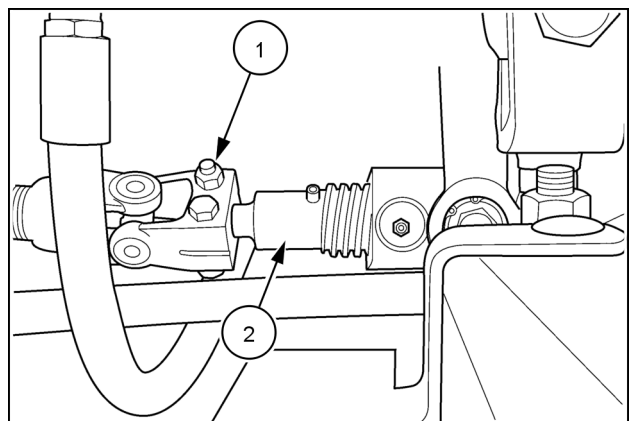

10041124 20

32. Remove four large bolts **(1)** with lock nuts .
33. Use appropriate lifting equipment to lift engine out of machine.
34. Mount the engine to an engine stand before removing the chain and hoist.

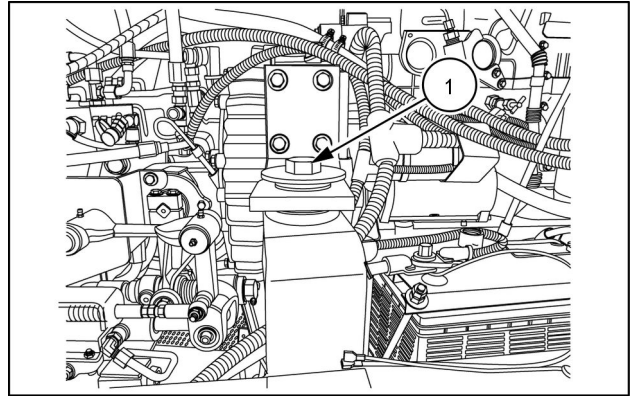

NHIL14WR01114AA 21

Engine and crankcase - Install - NEF 4 Cylinder

WD1204

NA

1. Use appropriate lifting equipment to lift engine and lower into position in machine.
2. Install two 1/2 in. x 3 in. cap screws with large washers **(1)** down through the isolation mounts, the rear frame engine mount brackets and locknuts before removing the chain and hoist.
3. Install two 1 in. x 4 in. cap screws with large washers and lock nuts in the front frame engine mount brackets. Torque to **407 N·m (300 lb ft)**.
4. Torque the rear mount bolts to **61 N·m (45 lb ft)**.

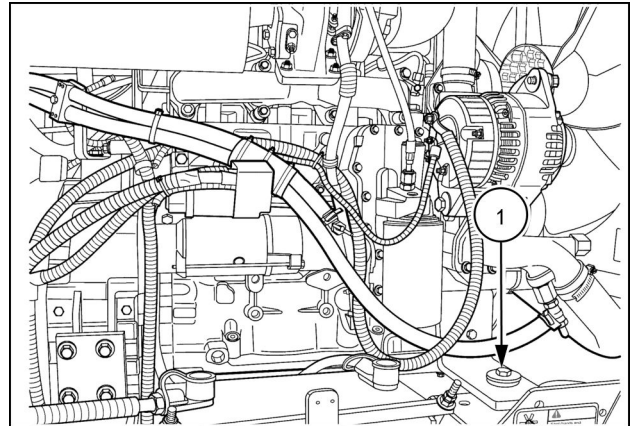

86070774 1

5. Apply silicone sealant such as **LOCTITE® 598™ BLACK** around mating surface of pump mounting plate **(1)**. Move the pumps and mounting plate into position against the flywheel housing and install twelve M10 flange bolts **(2)**.

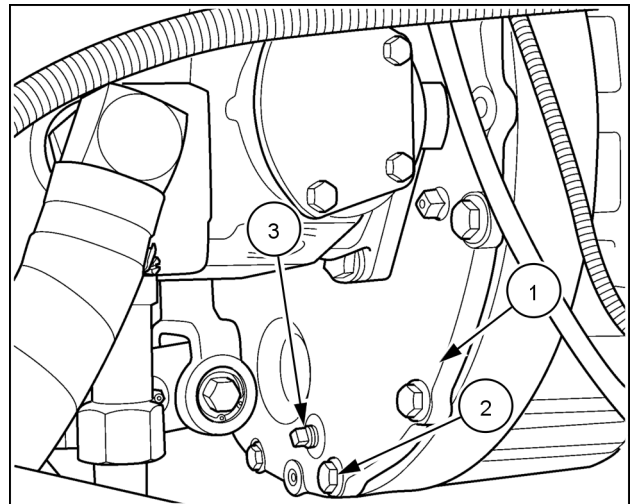

10041139 2

6. Install steering shaft yoke on splined shaft **(1)** in original position. Install two grade 8 clamp bolts with lock nuts **(2)** in steering yoke and tighten to **35 N·m (26 lb ft)**.

NOTICE: System may need to be readjusted for neutral.

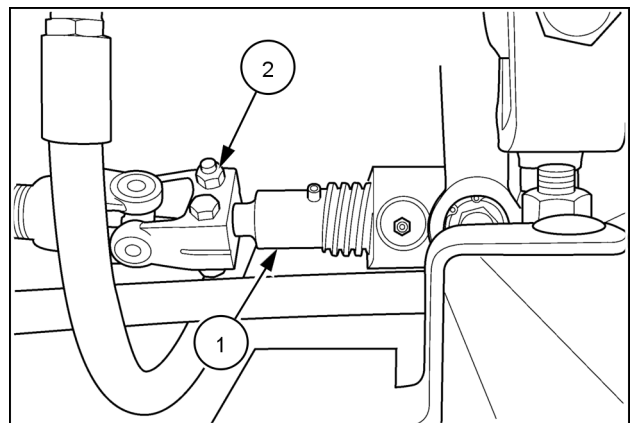

10041124 3

7. Remove breather plug (1) and fill gear case with **1.65 l (1.75 US qt)** to level of hole at plug (3) in step 5. Replace fill plug after verifying that breather will breathe.

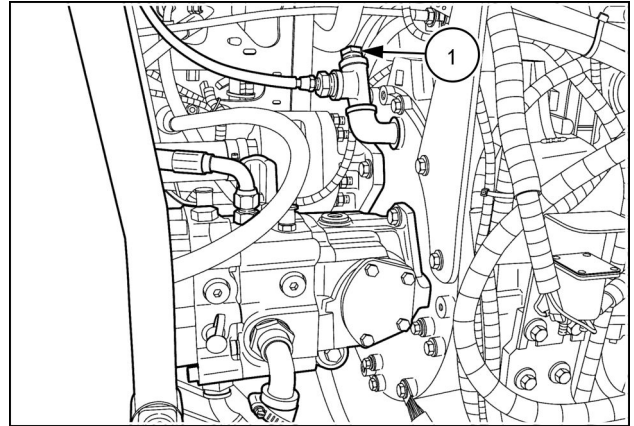

86070787 4

8. Arrange wiring harness around engine as original and install clamps in position to protect harness from damage in operation.
9. Connect red # 56 cable (1) to B+ terminal, yellow # FM112 wire of harness to 5 mm terminal W (2) and orange # FM053 wire to 4 mm terminal D+ (3) of alternator. Install three nuts.

NOTE: Terminal posts W and D+ have metric threads. Do not attempt to use inch series nuts on these terminals. An M5 nut is used at W, and an M4 nut is used at D+.

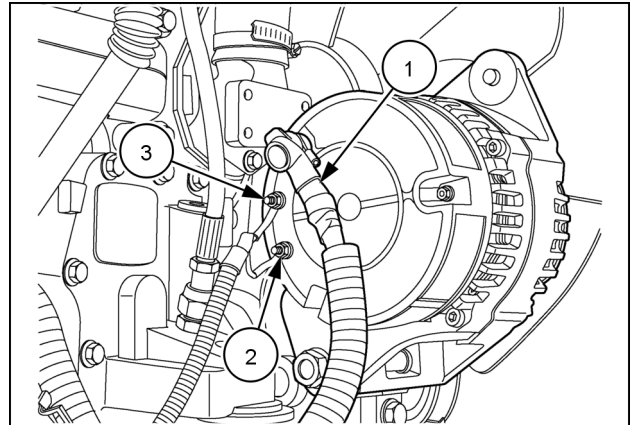

86075190 5

10. If equipped, install pump with hoses and PTO drive attached, and gasket. Install two M12 x 50 hex head flange bolts and lock washers (1) and tighten with M16 socket. Make sure suction hose (larger) is at bottom, as shown.

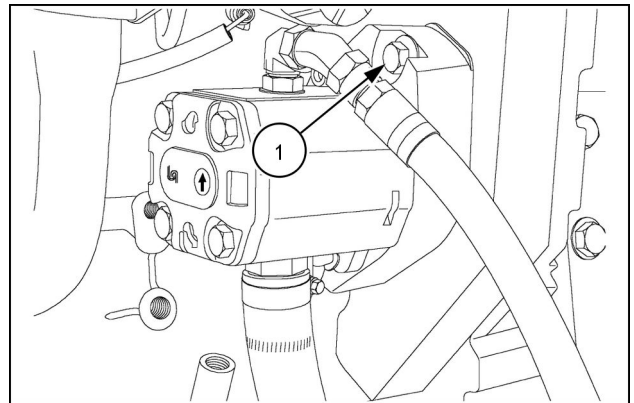

40044943N 6

11. Install drive belt (1) choosing grooves that provide best alignment.
12. Connect wire connector (2).

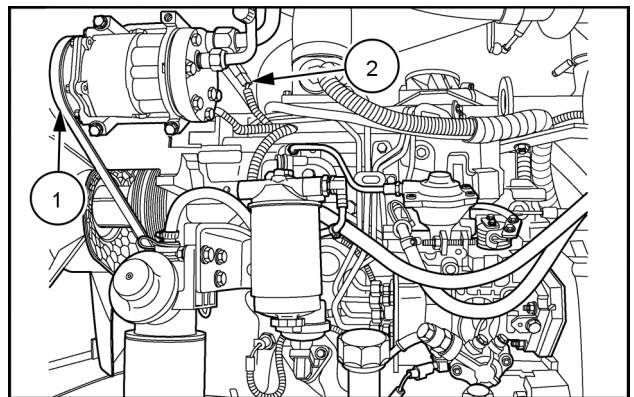

NHIL12WR00653AA 7



Suggest:

If the above button click is invalid.

Please download this document first, and then click the above link to download the complete manual.

Thank you so much for reading

13. Install three 5/16 in. x 3-3/4 in. cap screws with lock washers and flange nuts **(1)** in holes in compressor and through lower mount casting.

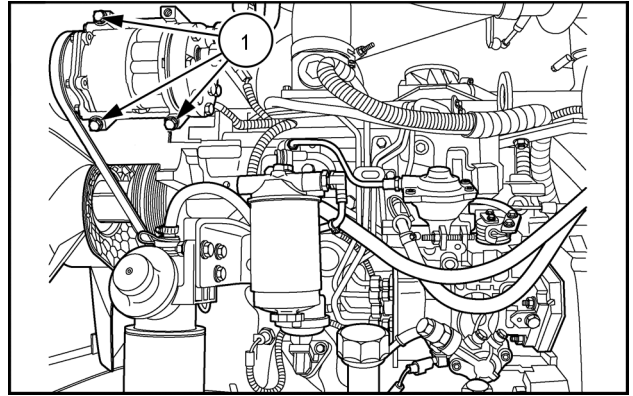

NHIL12WR00653AA 8

14. Connect wire # 330 **(1)** at left side of intake air heater, if so equipped, and wire # 193 **(2)** at right side and secure each with one M6 nut and lock washer. Tighten to **4 N·m (3 lb ft)**.

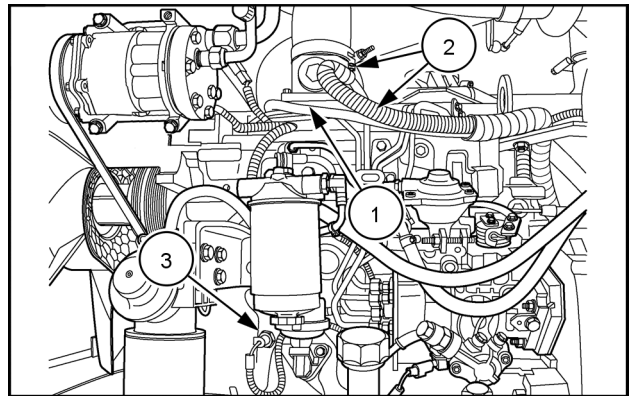

NHIL12WR00653AA 9

15. Connect wire # FM1041 to oil pressure switch **(3)**.

16. Install four 3/8 in. x 1-1/4 in. flange bolts, lock washers and flange nuts **(1)** to attach hood support frame to radiator top support and to front roof support structure.

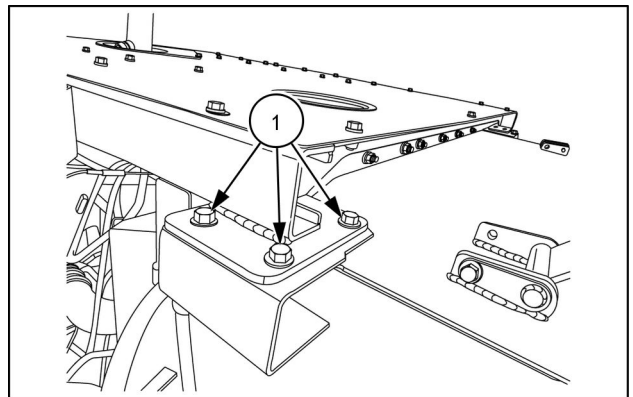

NHIL14WR01121AA 10

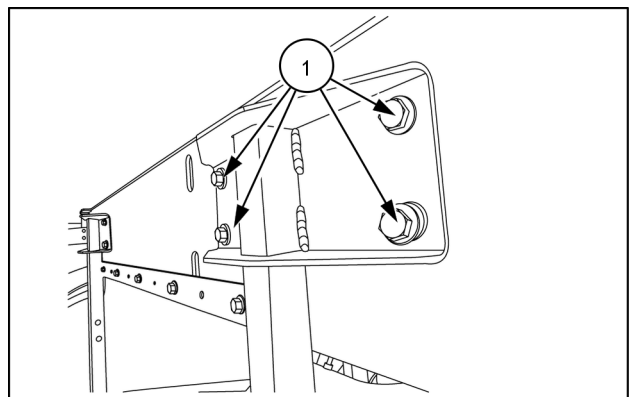

NHIL14WR01122AA 11

<https://www.ebooklibonline.com>

Hello dear friend!

Thank you very much for reading.

Enter the link into your browser.

The full manual is available for immediate download.

<https://www.ebooklibonline.com>