

STX AND STEIGER SERIES TRACTORS MASTER TABLE OF CONTENTS

THIS MANUAL, 84257306, COVERS THE FOLLOWING STX AND STEIGER SERIES TRACTORS:
STX 280, 330, 380, 430, 480, and 530 Series
Steiger 280, 330, 380, 430, 480, and 530 Series
Steiger 335, 385, 435, 485, and 535 Series

NOTE: *Engine repair information is not contained within this tractor Service Manual. For engine repair, refer to appropriate engine service manual as follows:*

87515687 - *For 8.3 & 9.0L 6 Cylinder, 24 Valve CNH Engine with High Pressure Common Rail Fuel System.*

87523642 - *For 12.9L 6 Cylinder, Engine.*

87737593 - *For 12.9L 6 Cylinder, Turbo Compound Engine.*

STANDARD TORQUE SPECIFICATIONS SECTION 1000 (Book 1 - 87525655)

SAFETY SECTION 1001 (Book 1 - 87525655)

LUBRICATION AND MAINTENANCE SECTION 1002 (Book 1 - 87525655)

ENGINE OIL SELECTION 1002-3

Synthetic Lubricants 1002-3

ENGINE OIL VISCOSITY/TEMPERATURE USAGE RECOMMENDATION 1002-3

ENGINE COOLANT SOLUTIONS 1002-4

STX280 AND STX330 TRACTORS 1002-5

Lubricants and Capacities 1002-5

Lubrication and Maintenance Chart 1002-6

STX380, 430, 480 AND 530 TRACTORS 1002-8

Lubricants and Capacities 1002-8

Lubrication and Maintenance Chart 1002-9

SPECIFICATIONS SECTION 1003 (Book 1 - 87525655)

STX280 AND STX330 TRACTORS 1003-3

Diesel Engine 1003-3

Engine Lubrication System 1003-3

Fuel System 1003-3

Air Intake System 1003-3

Transmission - Power Shift 1003-3

Transmission - Manual Shift 1003-3

Brakes 1003-4

Axle Differential And Final Drives 1003-4

Power Takeoff (If Equipped) 1003-4

Hydraulic System 1003-4

Hitch System (If Equipped) 1003-4

Drawbar 1003-5

Approximate Base Shipping Weights 1003-5

Approximate Component Weights 1003-5

Maximum Tractor Operating Weight 1003-5

STX380, 430, 480 AND 530 TRACTORS 1003-6

Diesel Engine 1003-6

Engine Lubrication System 1003-7

Fuel System 1003-7

Air Intake System 1003-7

Transmission - Powershift 1003-7

Transmission - Manual Shift 1003-7

STX AND STEIGER SERIES TRACTORS MASTER TABLE OF CONTENTS

Brakes	1003-7
Axle Differential And Final Drives	1003-8
Power Takeoff (If Equipped)	1003-8
Hydraulic System	1003-8
TwinFlow Hydraulics (If Equipped)	1003-8
Hitch System (If Equipped)	1003-9
Drawbar	1003-9
Track And Undercarriage (If Equipped)	1003-9
Approximate Base Shipping Weights	1003-10
Approximate Component Weights	1003-10
Maximum Tractor Operating Weight	1003-10
ENGINE REMOVAL AND INSTALLATION - STX380/430 TRACTORS	SECTION 2001 (Book 1 - 87525655)
SPECIAL TORQUE VALUES	2001-3
RECOMMENDED TOOLS	2001-3
ENGINE REMOVAL	2001-4
ENGINE INSTALLATION	2001-13
AIR INDUCTION SYSTEM - STX380/430 TRACTORS	SECTION 2002 (Book 1 - 87525655)
SPECIAL TORQUE VALUES	2002-2
AIR INDUCTION SYSTEM	2002-3
AIR INDUCTION SYSTEM DESCRIPTION	2002-4
AIR INDUCTION SYSTEM	2002-4
AIR FILTER ELEMENTS	2002-4
PRIMARY AND SECONDARY FILTER ELEMENT REMOVAL	2002-5
PRIMARY FILTER ELEMENT SERVICE	2002-7
RESTRICTION INDICATOR SWITCH REMOVAL AND TEST	2002-8
AIR CLEANER HOUSING REMOVAL	2002-9
ASPIRATOR STRATA TUBE CLEANING	2002-10
ASPIRATOR SAFETY CHECK VALVE REMOVAL AND TEST	2002-11
ASPIRATOR SAFETY VALVE INSTALLATION	2002-11
AIR CLEANER HOUSING INSTALLATION	2002-12
RESTRICTION INDICATOR SWITCH INSTALLATION	2002-13
SECONDARY AND PRIMARY FILTER ELEMENT INSTALLATION	2002-13
VISCOUS FAN DRIVE TEST AND HYDRAULIC FAN DRIVE TEST	SECTION 2003 (Book 1 - 87525655)
VISCOUS FAN DRIVE TEST - STX280, STX330, STX380, STX430	2003-3
HYDRAULIC FAN DRIVE TEST - STX480 AND STX530	2003-5
ENGINE REMOVAL AND INSTALLATION - STX280/330 TRACTORS	SECTION 2004 (Book 1 - 87525655)
SPECIAL TORQUE VALUES	2004-2
SPECIAL TOOLS	2004-2
ENGINE REMOVAL	2004-3
ENGINE INSTALLATION	2004-10
ENGINE REMOVAL AND INSTALLATION - STX480/530 TRACTORS	SECTION 2005 (Book 1 - 87525655)
SPECIAL TORQUE VALUES	2005-2
RECOMMENDED TOOLS	2005-2
ENGINE REMOVAL	2005-3
ENGINE INSTALLATION	2005-13

STX AND STEIGER SERIES TRACTORS MASTER TABLE OF CONTENTS

AIR INDUCTION SYSTEM - STX280/330 TRACTORS.....	SECTION 2006 (Book 1 - 87525655)
SPECIAL TORQUE VALUES	2006-3
AIR INDUCTION SYSTEM	2006-4
AIR FILTER ELEMENTS	2006-4
ENGINE AIR INDUCTION SYSTEM	2006-5
Primary And Secondary Filter Element Removal	2006-5
PRIMARY FILTER ELEMENT SERVICE	2006-7
RESTRICTION INDICATOR SWITCH REMOVAL AND TEST	2006-7
AIR CLEANER HOUSING REMOVAL	2006-8
Aspirator Strata Tube Cleaning	2006-10
ASPIRATOR SAFETY CHECK VALVE REMOVAL AND TEST	2006-12
ASPIRATOR SAFETY CHECK VALVE INSTALLATION	2006-13
AIR CLEANER HOUSING INSTALLATION	2006-14
RESTRICTION INDICATOR SWITCH INSTALLATION	2006-15
SECONDARY AND PRIMARY FILTER ELEMENT INSTALLATION	2006-16
AIR INDUCTION SYSTEM - STX480/530 TRACTORS.....	SECTION 2007 (Book 1 - 87525655)
SPECIAL TORQUE VALUES	2007-2
AIR INDUCTION SYSTEM	2007-3
AIR FILTER ELEMENTS	2007-4
Primary And Secondary Filter Element Removal	2007-5
Primary Filter Element Service	2007-7
RESTRICTION INDICATOR SWITCH REMOVAL AND TEST	2007-8
AIR CLEANER HOUSING REMOVAL	2007-9
ASPIRATOR STRATA TUBE CLEANING	2007-10
ASPIRATOR SAFETY CHECK VALVE REMOVAL AND TEST	2007-11
ASPIRATOR SAFETY VALVE INSTALLATION	2007-11
AIR CLEANER HOUSING INSTALLATION	2007-12
RESTRICTION INDICATOR SWITCH INSTALLATION	2007-13
SECONDARY AND PRIMARY FILTER ELEMENT INSTALLATION	2007-13
ENGINE REMOVAL AND INSTALLATION, STEIGER 485 TRACTORS	SECTION 2008 (Book 1A - 87740903)
SPECIAL TORQUE VALUES	2008-3
RECOMMENDED TOOLS	2008-3
ENGINE REMOVAL	2008-4
ENGINE INSTALLATION	2008-15
AIR INDUCTION SYSTEM, STEIGER 385, 435 AND 485 TRACTORS.....	SECTION 2009 (Book 1A - 87740903)
SPECIAL TORQUE VALUES	2009-2
AIR INDUCTION SYSTEM	2009-3
AIR INDUCTION SYSTEM DESCRIPTION	2009-4
AIR INDUCTION SYSTEM	2009-4
AIR FILTER ELEMENTS	2009-4
PRIMARY AND SECONDARY FILTER ELEMENT REMOVAL	2009-5
PRIMARY FILTER ELEMENT SERVICE	2009-7
RESTRICTION INDICATOR SWITCH REMOVAL AND TEST	2009-8
AIR CLEANER HOUSING REMOVAL	2009-9
ASPIRATOR STRATA TUBE CLEANING	2009-11
ASPIRATOR SAFETY CHECK VALVE REMOVAL AND TEST	2009-12
ASPIRATOR SAFETY VALVE INSTALLATION	2009-12
AIR CLEANER HOUSING INSTALLATION	2009-13
RESTRICTION INDICATOR SWITCH INSTALLATION	2009-14
SECONDARY AND PRIMARY FILTER ELEMENT INSTALLATION	2009-15
NAO 2006 MODEL YEAR POWERSHIFT ELECTRICAL SCHEMATIC	POSTER 87517737
NAO 2007 MODEL YEAR POWERSHIFT ELECTRICAL SCHEMATIC	POSTER 87710063
NAO 2008 MODEL YEAR POWERSHIFT ELECTRICAL SCHEMATIC	POSTER 87708839

<https://www.ebooklibonline.com>

Hello dear friend!

Thank you very much for reading.

Enter the link into your browser.

The full manual is available for immediate download.

<https://www.ebooklibonline.com>

STX AND STEIGER SERIES TRACTORS MASTER TABLE OF CONTENTS

ELECTRICAL SYSTEM - HOW IT WORKS AND TROUBLESHOOTING	SECTION 4001 (Book 1 - 87525655)
SPECIAL TOOLS	4001-3
FUSE AND RELAY IDENTIFICATION DELUXE CAB POWERSHIFT TRANSMISSION	4001-4
FUSE AND RELAY IDENTIFICATION DELUXE CAB 24 SPEED TRANSMISSION	4001-6
INSTRUMENTATION AND CONTROLS	4001-8
AUXILIARY AUTO MODE SWITCH (IF EQUIPPED)	4001-11
CONNECTOR AND COMPONENT LOCATION	4001-13
ELECTRICAL SYSTEMS SCHEMATICS AND DIAGNOSTICS	4001-89
AUDIO SYSTEM CIRCUIT OPERATION	4001-90
CHARGING SYSTEM	4001-95
POWER MIRROR SYSTEM	4001-99
POWER SEAT SYSTEM	4001-107
STARTING SYSTEM	4001-112
WIPER / WASHER SYSTEM	4001-121
BATTERY SERVICING AND TESTING	SECTION 4002 (Book 1 - 87525655)
SAFETY RULES	4002-3
SPECIFICATIONS	4002-4
ACCESS TO BATTERIES	4002-5
280 and 330 Tractors	4002-5
380, 430, 480 and 530 Tractors	4002-6
REMOVAL AND INSTALLATION OF BATTERIES	4002-7
BATTERY MAINTENANCE	4002-7
Electrolyte Level	4002-7
Inspecting And Cleaning A Battery	4002-7
Battery Condition Check	4002-8
Specific Gravity Check	4002-8
Procedure	4002-10
Three Minute Charge Test	4002-11
Testing Battery Cells With Cadmium Probes	4002-12
Battery Leakage Test	4002-14
Battery Fast Charging	4002-14
Battery Charging	4002-15
Activating Charges Batteries.....	4003-15
STEERING HAND PUMP & PRIORITY/CONTROL VALVE REMOVE/INSTALL - STX380/430/480/530 TRACTORS.....	SECTION 5001 (Book 2 - 87525656)
SPECIAL TOOLS	5001-2
SPECIAL TORQUE VALUES	5001-2
STEERING HAND PUMP REMOVAL	5001-3
STEERING TUBE LINES REMOVAL	5001-5
STEERING PRIORITY/CONTROL VALVE REMOVAL	5001-7
STEERING PRIORITY/CONTROL VALVE INSTALLATION	5001-8
STEERING TUBE LINES INSTALLATION	5001-9
STEERING HAND PUMP INSTALLATION	5001-11
STEERING SYSTEM - HOW IT WORKS.....	SECTION 5002 (Book 2A - 87618150)
ELECTROHYDRAULIC STEERING SYSTEM (EHPS)	5002-3
PRIORITY / STEERING CONTROL VALVE (EHPS)	5002-4
EHPS STEERING SYSTEM	5002-6
Engine Running Steering in Neutral Position	5002-7
Engine Running, Turning Left	5002-9
EHPS Steering System	5002-11
280 AND 330 MODELS STEERING LAYOUT	5002-12
380, 430, 480 AND 530 MODELS STEERING LAYOUT	5002-13

STX AND STEIGER SERIES TRACTORS MASTER TABLE OF CONTENTS

CENTER CONSOLE, STEERING COLUMN, PEDALS AND SWITCHES	SECTION 5003 (Book 2 - 87525656)
SPECIAL TOOLS	5003-3
SPECIAL TORQUE VALUES	5003-3
STEERING WHEEL REMOVAL	5003-4
TRANSMISSION SHIFT LEVER REMOVAL	5003-4
CENTER CONSOLE COVER REMOVAL	5003-7
CENTER CONSOLE COVER INSTALLATION	5003-9
TRANSMISSION SHIFT INSTALLATION	5003-11
STEERING WHEEL INSTALLATION	5003-14
STEERING COLUMN REMOVAL	5003-15
STEERING COLUMN INSTALLATION	5003-17
TILT STEERING COLUMN RELEASE CABLE REMOVAL	5003-20
TILT STEERING COLUMN RELEASE CABLE INSTALLATION	5003-21
CLUTCH AND BRAKE PEDAL ASSEMBLY REMOVAL	5003-23
CLUTCH AND BRAKE PEDAL ASSEMBLY INSTALLATION	5003-25
DECELERATION SWITCH REMOVAL	5003-28
DECELERATION SWITCH INSTALLATION	5003-29
CLUTCH POTENTIOMETER REMOVAL	5003-30
CLUTCH POTENTIOMETER INSTALLATION	5003-31
CLUTCH POTENTIOMETER CALIBRATION	5003-32
CLUTCH POTENTIOMETER CALIBRATION	5003-34
DIFFERENTIAL LOCK BRAKE SWITCH REMOVAL	5003-37
DIFFERENTIAL LOCK BRAKE SWITCH INSTALLATION	5003-37
HVAC PLENUM ACTUATOR MOTOR AND LOUVER REMOVAL	5003-39
HVAC PLENUM ACTUATOR MOTOR AND LOUVER INSTALLATION	5003-42
TRANSMISSION SHIFT LEVER DISASSEMBLY	5003-45
TRANSMISSION SHIFT LEVER ASSEMBLY	5003-52
STEERING COLUMN REPAIR	SECTION 5004 (Book 2 - 87525656)
TILT STEERING COLUMN DISASSEMBLY	5004-3
TILT STEERING COLUMN ASSEMBLY	5004-5
ACCUSTEER® STEERING SYSTEM - HOW IT WORKS	SECTION 5005 (Book 2A - 87618150)
SYSTEM COMPONENTS	5005-2
ELECTROHYDRAULIC POWER STEERING SYSTEM (EHPS) WITH ACCUSTEER®	5005-3
PRIORITY / STEERING CONTROL VALVE (EHPS)	5005-5
NEUTRAL POSITION - NO STEERING	5005-6
FOLDOUT - NEUTRAL POSITION - NO STEERING	5005-7
STEERING LEFT IN COMBINATION MODE (LESS THAN 5 DEGREES)	5005-8
FOLDOUT - STEERING LEFT, COMBINATION MODE (Less than 5 Degrees)	5005-9
STEERING LEFT IN COMBINATION MODE (MORE THAN 10 DEGREES)	5005-10
FOLDOUT - STEERING LEFT, COMBINATION MODE (More than 10 Degrees)	5005-11
EMERGENCY STEERING	5005-12
ACCUSTEER®, ARTICULATED REAR STEERING LAYOUT	5005-13
ACCUSTEER®, FRONT STEERING LAYOUT	5005-14
STEERING HAND PUMP & PRIORITY/CONTROL VALVE REMOVE/INSTALL - STX280/330	SECTION 5011 (Book 2 - 87525656)
SPECIAL TOOLS	5011-2
SPECIAL TORQUE VALUES	5011-2
STEERING HAND PUMP REMOVAL	5011-3
STEERING TUBE LINES REMOVAL	5011-5
STEERING PRIORITY/CONTROL VALVE REMOVAL	5011-7
STEERING PRIORITY/CONTROL VALVE INSTALLATION	5011-10
STEERING TUBE LINES INSTALLATION	5011-13
STEERING HAND PUMP INSTALLATION	5011-15

STX AND STEIGER SERIES TRACTORS MASTER TABLE OF CONTENTS

POWERSHIFT TRANSMISSION REMOVAL AND INSTALLATION -

STX280/330 TRACTORS.....	SECTION 6001 (Book 2 - 87525656)
SPECIAL TORQUE VALUES	6001-2
SPECIAL TOOLS	6001-2
TRANSMISSION REMOVAL	6001-3
TRANSMISSION INSTALLATION	6001-9

ENGINE/TRANS DRIVE COUPLER REMOVAL/INSTALLATION -

STX480/530 TRACTORS.....	SECTION 6002 (Book 2 - 87525656)
SPECIAL TORQUE VALUES	6002-2
DRIVE COUPLER REMOVAL	6002-3
DRIVE COUPLER INSTALLATION	6002-6

16 SPEED POWERSHIFT TRANSMISSION REPAIR..... SECTION 6003 (Book 2 - 87525656)

SPECIFICATIONS	6003-3
SPECIAL TORQUE VALUES	6003-3
SPECIAL TOOLS	6003-4
TRANSMISSION DISASSEMBLY	6003-7
INPUT (FIRST) SHAFT DISASSEMBLY	6003-18
PUMP (SECOND) SHAFT DISASSEMBLY	6003-27
MASTER CLUTCH (FOURTH) SHAFT DISASSEMBLY	6003-33
OUTPUT (FIFTH) SHAFT DISASSEMBLY	6003-41
COUNTER (THIRD) SHAFT DISASSEMBLY	6003-48
CLEANING AND INSPECTION	6003-50
CLUTCH PACK CLEARANCE AND CLUTCH PACK TRAVEL TEST	6003-52
1F, 1R, 2F AND 2R CLUTCH GEAR BEARING PRELOAD TEST	6003-55
INPUT (FIRST) SHAFT ASSEMBLY	6003-60
PUMP (SECOND) SHAFT ASSEMBLY	6003-74
MASTER CLUTCH (FOURTH) SHAFT ASSEMBLY	6003-84
OUTPUT (FIFTH) SHAFT ASSEMBLY	6003-98
COUNTER (THIRD) SHAFT BEARING ASSEMBLY	6003-109
TRANSMISSION ASSEMBLY	6003-110

16 SPEED POWERSHIFT TRANSMISSION HOW IT WORKS SECTION 6004 (Book 2 - 87525656)

GENERAL DESCRIPTION OF OPERATION	6004-3
Regulator Valve	6004-4
Lube Regulator Valve	6004-5
Master Clutch Lube Valve	6004-5
Range Selector Valve	6004-6
MASTER CLUTCH CONTROL VALVE	6004-7
Transmission Power Flow	6004-8
Default Settings	6004-8
Helical-cut Gears	6004-8
Shifting The Powershift Transmission	6004-9

PTO CLUTCH REMOVAL AND INSTALLATION - STX280/330 TRACTORS. SECTION 6005 (Book 2 - 87525656)

SPECIAL TORQUE VALUES	6005-2
PTO CLUTCH REMOVAL	6005-3
PTO CLUTCH INSTALLATION	6005-5

PTO CLUTCH REMOVAL AND INSTALLATION -

STX380 THROUGH STX530 TRACTORS..... SECTION 6006 (Book 2 - 87525656)

SPECIAL TORQUE VALUES	6006-2
PTO CLUTCH ASSEMBLY REMOVAL	6006-3
PTO CLUTCH ASSEMBLY INSTALLATION	6006-9

STX AND STEIGER SERIES TRACTORS MASTER TABLE OF CONTENTS

PTO DRIVE UNIT (CLUTCH) REPAIR	SECTION 6007 (Book 2 - 87525656)
SPECIAL TORQUE VALUES	6007-3
SPECIFICATIONS	6007-3
PTO DRIVE UNIT DISASSEMBLY	6007-4
PTO DRIVE UNIT ASSEMBLY	6007-15
PTO SYSTEM - HOW IT WORKS AND TROUBLESHOOTING	SECTION 6008 (Book 2 - 87525656)
SPECIFICATIONS	6008-2
POWER TAKE OFF	6008-3
PTO LUBRICATION	6008-4
PTO CONTROL	
PTO Control Switch	6008-5
To Operate the PTO	6008-5
To Stop the PTO	6008-5
PTO Electrical Circuit	6008-6
PTO Switch in the OFF Position	6008-7
PTO Switch in the ON Position	6008-8
Diode Suppressed PTO Coil	6008-9
Neutral Start Feature	6008-9
PTO VALVE	
Operational Modes	6008-10
PTO Control Valve Operation	6008-12
PTO Clutch Disengaged	6008-13
PTO Modulated Engagement	6008-14
PTO Fully Engaged	6008-15
PTO Clutch Drive	6008-16
PTO Clutch	6008-17
PTO Brake	6008-18
PTO Drop Box and Clutch	6008-19
Engine RPM Speed Circuit	6008-19
PTO SYSTEM TROUBLESHOOTING	
PTO Will Not Engage	6008-20
PTO Will Not Disengage	6008-21
PTO TRANSFER CASE REMOVAL AND INSTALLATION	SECTION 6009 (Book 2 - 87525656)
SPECIAL TORQUE VALUES	6009-2
SPECIAL TOOLS	6009-2
TRANSFER CASE REMOVAL	6009-3
TRANSFER CASE INSTALLATION	6009-10
PTO DROPBOX REPAIR	SECTION 6010 (Book 2 - 87525656)
SPECIFICATIONS	6010-2
SPECIAL TORQUE VALUES	6010-2
PTO DROPBOX DISASSEMBLY	6010-3
EXPLODED VIEW PTO DROPBOX ASSEMBLY	6010-9
PTO DROPBOX ASSEMBLY	6010-10
REAR DRIVE LINE AND CARRIER BEARING	SECTION 6011 (Book 2 - 87525656)
SPECIAL TORQUE VALUES	6011-2
REAR DRIVE LINE AND CARRIER BEARING REMOVAL	6011-3
REAR DRIVE LINE AND CARRIER BEARING INSTALLATION	6011-5

STX AND STEIGER SERIES TRACTORS MASTER TABLE OF CONTENTS

PTO DRIVELINE HANGER BEARING.....	SECTION 6012 (Book 2 - 87525656)
SPECIAL TORQUE VALUES	6012-2
PTO DRIVELINE HANGER BEARING REMOVAL	6012-3
HANGER BEARING ASSEMBLY REPAIR (Exploded View)	6012-5
HANGER BEARING DISASSEMBLY	6012-6
HANGER BEARING ASSEMBLY	6012-7
PTO DRIVELINE HANGER BEARING INSTALLATION	6012-10
CHARGE PUMP REPAIR FOR 16 SPEED POWERSHIFT TRANSMISSION	SECTION 6013 (Book 3 - 87525657)
SPECIFICATIONS	6013-3
SPECIAL TORQUE VALUES	6013-3
PUMP DISASSEMBLY	6013-4
PUMP ASSEMBLY	6013-7
PTO VALVE.....	SECTION 6014 (Book 3 - 87525657)
SPECIAL TORQUE VALUES	6014-2
PTO VALVE REMOVAL	6014-3
PTO VALVE DISASSEMBLY	6014-4
CLEANING AND INSPECTION	6014-7
PTO VALVE SOLENOID TESTS	6014-8
PTO VALVE SECTIONAL VIEW	6014-9
PTO VALVE ASSEMBLY	6014-10
PTO VALVE INSTALLATION	6014-13
FRONT AXLE REMOVAL AND INSTALLATION -	
STX380 THROUGH 530 WHEEL TRACTORS.....	SECTION 6015 (Book 3 - 87525657)
SPECIAL TORQUE VALUES	6015-3
SPECIAL TOOLS	6015-3
RECOMMENDED TOOLS	6015-3
FRONT AXLE REMOVAL	6015-4
FRONT AXLE INSTALLATION	6015-10
REAR AXLE REMOVAL AND INSTALLATION -	
STX380 THROUGH 530 WHEEL TRACTORS.....	SECTION 6016 (Book 3 - 87525657)
SPECIAL TORQUE VALUES	6016-3
SPECIAL TOOLS	6016-3
RECOMMENDED TOOLS	6016-3
REAR AXLE REMOVAL	6016-4
REAR AXLE INSTALLATION	6016-13
FRONT AXLE REMOVAL AND INSTALLATION 380, 430, 480, 530 and	
385, 435, 485, and 535 QUADTRAC Tractors	SECTION 6017 (Book 3B - 87740904)
SPECIAL TORQUE VALUES	6017-3
SPECIAL TOOLS	6017-3
RECOMMENDED TOOLS	6017-3
FRONT AXLE REMOVAL	6017-4
FRONT AXLE INSTALLATION	6017-15
REAR AXLE REMOVAL AND INSTALLATION 380, 430, 480, 530 and	
385, 435, 485, and 535 QUADTRAC Tractors	SECTION 6018 (Book 3B - 87740904)
SPECIAL TORQUE VALVES	6018-3
SPECIAL TOOLS	6018-3
RECOMMENDED TOOLS	6018-4
REAR AXLE REMOVAL	6018-5
REAR AXLE INSTALLATION	6018-15

STX AND STEIGER SERIES TRACTORS MASTER TABLE OF CONTENTS

TRACK REMOVAL AND INSTALLATION - QUADTRAC TRACTORS	SECTION 6019 (Book 3 - 87525657)
SPECIAL TORQUE VALUES	6019-2
SPECIAL TOOLS	6019-2
TRACK REMOVAL	6019-3
TRACK INSTALLATION	6019-8
TRACK ALIGNMENT	6019-10
FRONT AND REAR AXLE REPAIR -	
AXLE MODEL 500 AND 510 FOR WHEEL TRACTORS	SECTION 6020 (Book 3 - 87525657)
AXLE IDENTIFICATION	6020-4
AXLE SPECIFICATIONS	6020-5
SPECIAL TORQUE VALUES	6020-5
SPECIAL TOOLS	6020-6
RECOMMENDED TOOLS	6020-8
GENERAL INFORMATION	6020-13
AXLE FINAL DRIVE REMOVAL	6020-13
FINAL DRIVE DISASSEMBLY	6020-15
PLANETARY CARRIER DISASSEMBLY	6020-19
PLANETARY CARRIER ASSEMBLY	6020-20
FINAL DRIVE HOUSING ASSEMBLY	6020-22
PINION CARRIER REMOVAL	6020-28
PINION CARRIER DISASSEMBLY	6020-32
PINION CARRIER ASSEMBLY	6020-34
BRAKE CARRIER/BEARING SUPPORT REMOVAL	6020-39
BRAKE CARRIER/BEARING SUPPORT DISASSEMBLY	6020-40
RH BRAKE CARRIER ASSEMBLY PROCEDURES	6020-44
DIFFERENTIAL REMOVAL AND DISASSEMBLY	6020-49
DIFFERENTIAL CASE ASSEMBLY PROCEDURES	6020-53
LH DIFFERENTIAL BEARING SUPPORT DISASSEMBLY	6020-59
LH DIFFERENTIAL BEARING SUPPORT ASSEMBLY	6020-60
ADJUSTING BEVEL PINION GEAR DEPTH	6020-61
SETTING DIFFERENTIAL CARRIER BEARING PRELOAD	6020-64
SETTING RING/PINION GEAR BACKLASH	6020-67
CHECKING FOR CORRECT BEVEL PINION/GEAR TOOTH CONTACT	6020-68
BRAKE CARRIER/BEARING SUPPORT INSTALLATION	6020-70
PERFORMING THE BRAKE LEAK DOWN TEST	6020-73
DIFFERENTIAL LOCK LEAK TEST	6020-74
FINAL DRIVE INSTALLATION	6020-77
FRONT AND REAR AXLE REPAIR -	
AXLE MODEL 500 AND 510 FOR QUADTRAC TRACTORS	SECTION 6021 (Book 3 - 87525657)
AXLE SPECIFICATIONS	6021-4
SPECIAL TORQUE VALUES	6021-4
SPECIAL TOOLS	6021-5
RECOMMENDED TOOLS	6021-6
GENERAL INFORMATION	6021-11
AXLE FINAL DRIVE REMOVAL	6021-11
FINAL DRIVE DISASSEMBLY	6021-14
PLANETARY CARRIER DISASSEMBLY	6021-17
PLANETARY CARRIER ASSEMBLY	6021-18
FINAL DRIVE HOUSING ASSEMBLY	6021-21
FINAL DRIVE OFFSET HOUSING DISASSEMBLY	6021-26
OFFSET HOUSING ASSEMBLY	6021-28
PINION CARRIER REMOVAL	6021-31
PINION CARRIER DISASSEMBLY	6021-35
PINION CARRIER ASSEMBLY	6021-37
BRAKE CARRIER/BEARING SUPPORT REMOVAL	6021-42

STX AND STEIGER SERIES TRACTORS MASTER TABLE OF CONTENTS

BRAKE CARRIER/BEARING SUPPORT DISASSEMBLY	6021-43
RH BRAKE CARRIER ASSEMBLY PROCEDURES	6021-47
DIFFERENTIAL REMOVAL AND DISASSEMBLY	6021-52
DIFFERENTIAL CASE ASSEMBLY PROCEDURES	6021-56
LH DIFFERENTIAL BEARING SUPPORT DISASSEMBLY	6021-62
LH DIFFERENTIAL BEARING SUPPORT ASSEMBLY	6021-63
ADJUSTING BEVEL PINION GEAR DEPTH	6021-64
SETTING DIFFERENTIAL CARRIER BEARING PRELOAD	6021-67
SETTING RING/PINION GEAR BACKLASH	6021-70
CHECKING FOR CORRECT BEVEL PINION/GEAR TOOTH CONTACT	6021-71
BRAKE CARRIER/BEARING SUPPORT INSTALLATION	6021-73
PERFORMING THE BRAKE LEAK DOWN TEST	6021-76
DIFFERENTIAL LOCK LEAK TEST	6021-77
OFFSET HOUSING INSTALLATION	6021-80
UNDERCARRIAGE/DRIVE WHEEL REMOVAL/INSTALLATION - QUADTRAC TRACTORS.....	SECTION 6022 (Book 3 - 87525657)
SPECIAL TORQUE VALUES	6022-2
SPECIAL TOOLS	6022-2
UNDERCARRIAGE REMOVAL	6022-3
UNDERCARRIAGE INSTALLATION	6022-6
DRIVE WHEEL REMOVAL	6022-9
DRIVE WHEEL INSTALLATION	6022-10
UNDERCARRIAGE REPAIR - STX QUADTRAC® MODEL TRACTORS.....	SECTION 6023 (Book 3A - 87618151)
SPECIAL TORQUE VALUES	6023-3
SPECIAL TOOLS	6023-3
ROLLER WHEEL REMOVAL AND DISASSEMBLY	6023-4
ROLLER WHEEL SEAL AND BEARING INSTALLATION AND ASSEMBLY	6023-7
ROLLER WHEEL AXLE REMOVAL	6023-12
ROLLER WHEEL AXLE INSTALLATION	6023-12
OUTER IDLER WHEEL SEAL AND BEARING REMOVAL	6023-13
OUTER IDLER WHEEL BEARING AND SEAL INSTALLATION	6023-15
METAL FACE SEAL INSTALLATION INSTRUCTIONS	6023-16
OUTER IDLER SEAL INSTALLATION AND ASSEMBLY	6023-16
REAR IDLER AXLE, BEARINGS AND SEAL REMOVAL	6023-21
REAR IDLER AXLE, WHEEL BEARINGS AND SEAL ASSEMBLY AND INSTALLATION	6023-24
METAL FACE SEAL INSTALLATION INSTRUCTIONS	6023-25
PIVOT AXLE, BEARING AND SEAL REMOVAL	6023-32
PIVOT SHAFT SEAL AND BEARING REMOVAL	6023-36
PIVOT AXLE, SEAL AND BEARING INSTALLATION	6023-37
IDLER WHEEL BEARING AND SEAL INSTALLATION	6023-38
METAL FACE SEAL INSTALLATION INSTRUCTIONS	6023-39
TENSION CYLINDER REMOVAL AND DISASSEMBLY	6023-47
TENSION CYLINDER ASSEMBLY AND INSTALLATION	6023-50
ROLLER WHEEL ASSEMBLY AND REAR ISOLATER MOUNT REMOVAL	6023-53
ISOLATOR MOUNTS AND ROLLER WHEEL ASSEMBLY INSTALLATION	6023-55

STX AND STEIGER SERIES TRACTORS MASTER TABLE OF CONTENTS

16 SPEED POWERSHIFT TRANSMISSION	
Range Selector, Pressure Regulator and Master Clutch Valve Repair	SECTION 6024 (Book 3B - 87740904)
SPECIAL TORQUE VALUES	6024-3
REGULATOR VALVE DISASSEMBLY	6024-4
CLEANING, INSPECTION AND SOLENOID VALVE TEST	6024-12
REGULATOR VALVE ASSEMBLY	6024-15
RANGE SELECTOR VALVE DYNAMIC TEST	6024-23
RANGE SELECTOR PWM VALVE TEST	6024-26
RANGE SELECTOR VALVE DISASSEMBLY	6024-29
RANGE SELECTOR VALVE ASSEMBLY	6024-32
16-SPEED POWERSHIFT TRANSMISSION	SECTION 6025 (Book 3A - 87618151)
RECOMMENDED TOOLS	6025-3
SPECIAL TORQUE VALUES	6025-3
TRANSMISSION TROUBLESHOOTING	6025-4
Important General Information	6025-4
Fault Code Retrieval	6025-4
Fault Codes Recorded	6025-6
No Fault Codes Recorded	6025-6
Solenoid Swap Test	6025-7
CLUTCH TEST PORT IDENTIFICATION	6025-8
Transmission Clutch Pressure Test	6025-9
TEST PORT IDENTIFICATION	6025-14
PRESSURE TEST SPECIFICATIONS AND WORKSHEETS	6025-15
LUBE TEST PORT IDENTIFICATION	6025-18
LUBRICATION CIRCUIT PRESSURE TEST	6025-19
MASTER CLUTCH LUBE TEST	6025-21
PTO CLUTCH PRESSURE TEST	6025-22
PTO AND TRANSMISSION PRESSURE TEST REASSEMBLY	6025-24
24 SPEED MANUAL TRANSMISSION -	
HOW IT WORKS, PRESSURE TESTING AND REPAIR	SECTION 6026 (Book 3 - 87525657)
SPECIFICATIONS	6026-4
SPECIAL TORQUE VALUES	6026-5
SPECIAL TOOLS	6026-6
PRESSURE TESTING SPECIFICATIONS	6026-8
GENERAL SETUP PROCEDURE	6026-9
TRANSMISSION PRESSURE TEST PORT LOCATIONS	6026-11
TESTING THE LUBRICATION PRESSURE	6026-13
TRANSMISSION SERIAL NUMBER IDENTIFICATION	6026-14
TRANSMISSION LUBRICATION CIRCUIT	6026-15
TRANSMISSION OIL FLOW CHART	6026-16
DESCRIPTION OF OPERATION	6026-20
TRANSMISSION POWER FLOW	6026-24
STARTING IN A FORWARD SPEED	6026-26
STARTING IN A REVERSE SPEED	6026-27
TROUBLESHOOTING GUIDE	6026-35
NEUTRAL SAFETY SWITCH ADJUSTMENT	6026-40
TRANSMISSION SPEED SENSOR ADJUSTMENT	6026-40
TRANSMISSION DISASSEMBLY	6026-41
SHIFT LEVER SEAL REPLACEMENT	6026-53
INPUT SHAFT DISASSEMBLY	6026-54
INPUT SHAFT ASSEMBLY	6026-59
PUMP SHAFT DISASSEMBLY	6026-72
PUMP SHAFT ASSEMBLY	6026-75
SPEED SHAFT DISASSEMBLY	6026-81
SPEED SHAFT ASSEMBLY	6026-84

STX AND STEIGER SERIES TRACTORS MASTER TABLE OF CONTENTS

CENTER SHAFT DISASSEMBLY	6026-88
CENTER SHAFT ASSEMBLY	6026-90
RANGE SHAFT DISASSEMBLY	6026-94
RANGE SHAFT ASSEMBLY	6026-96
TRANSMISSION ASSEMBLY	6026-100
HIGH-LOW CLUTCH CONTROL ASSEMBLY	6026-118
HIGH-LOW CONTROL VALVE DISASSEMBLY	6026-119
REGULATOR VALVE ASSEMBLY	6026-121
REGULATOR VALVE DISASSEMBLY AND ASSEMBLY	6026-122
MASTER CLUTCH CONTROL VALVE ASSEMBLY	6026-123
MASTER CLUTCH CONTROL VALVE DISASSEMBLY AND ASSEMBLY	6026-124
LOCKOUT VALVE ASSEMBLY	6026-126
LOCKOUT VALVE DISASSEMBLY AND ASSEMBLY	6026-127
MASTER CLUTCH CABLE ADJUSTMENT	6026-128
24 SPEED MANUAL TRANSMISSION REMOVAL AND INSTALLATION SECTION 6027 (Book 3 - 87525657)	
SPECIAL TOOLS	6027-3
SPECIAL TORQUE VALUES	6027-3
24 SPEED TRANSMISSION REMOVAL	6027-4
24 SPEED TRANSMISSION INSTALLATION	6027-13
MASTER CLUTCH ADJUSTMENT	6027-23
SHIFT LEVER LINKAGE ADJUSTMENT	6027-24
FRONT AND REAR AXLE REPAIR - AXLE MODEL 450 AND 460 SECTION 6028 (Book 4 - 87525658)	
AXLE IDENTIFICATION	6028-4
AXLE SPECIFICATIONS	6028-5
SPECIAL TORQUE VALUES	6028-5
SPECIAL TOOLS	6028-6
RECOMMENDED TOOLS	6028-7
GENERAL INFORMATION	6028-13
AXLE FINAL DRIVE REMOVAL	6028-13
FINAL DRIVE DISASSEMBLY	6028-15
PLANETARY CARRIER DISASSEMBLY	6028-19
PLANETARY CARRIER ASSEMBLY	6028-20
FINAL DRIVE HOUSING ASSEMBLY	6028-22
FRONT COVER REMOVAL	6028-28
FRONT COVER DISASSEMBLY	6028-31
FRONT COVER ASSEMBLY	6028-33
RH SIDE BRAKE CARRIER REMOVAL	6028-39
BRAKE CARRIER/BEARING SUPPORT DISASSEMBLY	6028-40
RH BRAKE CARRIER ASSEMBLY PROCEDURES	6028-44
DIFFERENTIAL REMOVAL	6028-49
DIFFERENTIAL CASE DISASSEMBLY PROCEDURES	6028-50
DIFFERENTIAL CASE ASSEMBLY PROCEDURES	6028-53
LH DIFFERENTIAL BEARING CARRIER DISASSEMBLY	6028-59
LH DIFFERENTIAL BEARING CARRIER ASSEMBLY	6028-60
ADJUSTING BEVEL PINION GEAR DEPTH	6028-61
SETTING DIFFERENTIAL CARRIER BEARING PRELOAD	6028-64
SETTING RING/PINION GEAR BACKLASH	6028-67
RH BEARING CARRIER/BRAKE SUPPORT INSTALLATION	6028-71
FRONT COVER INSTALLATION	6028-72
LEAK TESTING THE SERVICE BRAKE	6028-75
LEAK TESTING THE PARK BRAKE	6028-76
LEAK TESTING THE DIFFERENTIAL LOCK	6028-77
FINAL DRIVE INSTALLATION	6028-79

STX AND STEIGER SERIES TRACTORS MASTER TABLE OF CONTENTS

POWERSHIFT TRANSMISSION REMOVAL/INSTALLATION - STX380/430/480/530 TRACTORS.....	SECTION 6029 (Book 4 - 87525658)
SPECIAL TORQUE VALUES	6029-3
SPECIAL TOOLS	6029-3
TRANSMISSION REMOVAL	6029-4
TRANSMISSION INSTALLATION	6029-10
 ENGINE/TRANS DRIVE COUPLER REMOVE/INSTALL - STX280/330 AND ACCUSTEER™.....	 SECTION 6030 (Book 4 - 87525658)
SPECIAL TORQUE VALUES	6030-2
DRIVE COUPLER REMOVAL	6030-3
DRIVE COUPLER INSTALLATION	6030-5
 FRONT AXLE REMOVAL AND INSTALLATION - STX280/330 TRACTORS .	SECTION 6031 (Book 4 - 87525658)
SPECIAL TORQUE VALUES	6031-3
SPECIAL TOOLS	6031-3
RECOMMENDED TOOLS	6031-3
FRONT AXLE REMOVAL	6031-4
FRONT AXLE INSTALLATION	6031-11
 REAR AXLE REMOVAL AND INSTALLATION - STX280/330 TRACTORS....	SECTION 6032 (Book 4 - 87525658)
SPECIAL TORQUE VALUES	6032-3
SPECIAL TOOLS	6032-3
RECOMMENDED TOOLS	6032-3
REAR AXLE REMOVAL	6032-4
REAR AXLE INSTALLATION	6032-12
 FRONT/REAR AXLE REPAIR - MODEL 300 SERIES AXLES FOR STX280/330 TRACTORS	 SECTION 6033 (Book 4 - 87525658)
AXLE SPECIFICATIONS	6033-4
SPECIAL TORQUE VALUES	6033-4
SPECIAL TOOLS	6033-5
AXLE FINAL DRIVE REMOVAL	6033-12
FINAL DRIVE DISASSEMBLY	6033-14
PLANETARY CARRIER DISASSEMBLY	6033-18
PLANETARY CARRIER ASSEMBLY	6033-19
FINAL DRIVE HOUSING ASSEMBLY	6033-21
FRONT COVER REMOVAL	6033-26
FRONT COVER DISASSEMBLY	6033-28
FRONT COVER ASSEMBLY	6033-31
RH SIDE BRAKE CARRIER REMOVAL	6033-37
BRAKE CARRIER/BEARING SUPPORT DISASSEMBLY	6033-38
RH BRAKE CARRIER ASSEMBLY PROCEDURES	6033-42
DIFFERENTIAL REMOVAL	6033-47
DIFFERENTIAL CASE DISASSEMBLY PROCEDURES	6033-48
DIFFERENTIAL CASE ASSEMBLY PROCEDURES	6033-51
LH DIFFERENTIAL BEARING CARRIER DISASSEMBLY	6033-57
LH DIFFERENTIAL BEARING CARRIER ASSEMBLY	6033-58
ADJUSTING BEVEL PINION GEAR DEPTH	6033-59
SETTING DIFFERENTIAL CARRIER BEARING PRELOAD	6033-62
SETTING RING/PINION GEAR BACKLASH	6033-65
RH BEARING CARRIER/BRAKE SUPPORT INSTALLATION	6033-69
FRONT COVER INSTALLATION	6033-70
LEAK TESTING THE SERVICE BRAKE	6033-73
LEAK TESTING THE PARK BRAKE	6033-74
LEAK TESTING THE DIFFERENTIAL LOCK	6033-75
FINAL DRIVE INSTALLATION	6033-77

STX AND STEIGER SERIES TRACTORS MASTER TABLE OF CONTENTS

ENGINE/TRANSMISSION DRIVE COUPLER REMOVAL/INSTALL - STX380/430 TRACTORS.....	SECTION 6034 (Book 4 - 87525658)
SPECIAL TORQUE VALUES	6034-2
DRIVE COUPLER REMOVAL	6034-3
DRIVE COUPLER INSTALLATION	6034-6
 POWER BRAKES SYSTEM HOW IT WORKS AND TROUBLESHOOTING ..	SECTION 7001 (Book 4 - 87525658)
BRAKE SYSTEM	7001-3
General Information	7001-3
General Description	7001-4
Axle Pump	7001-4
Axle Cooling Filter	7001-5
Axle Lube Solenoid Valve	7001-5
Pressure/Lube Control Valve	7001-6
Brake Lubrication and Jet Pump	7001-6
Pressure/Lube Control Valve	7001-7
Regulated Pressure Spool	7001-8
Park Brake/Tow Valve	7001-10
Park Brake Applied	7001-11
Park Brake Released	7001-11
Tow Valve	7001-12
BRAKE CIRCUIT COMPONENTS	7001-13
Brake Pedal	7001-13
Brake Control Valve	7001-13
Brake Clutch Pack	7001-13
Axle Brake Cylinders	7001-14
HYDRAULIC BRAKE CONTROL	7001-14
General Description	7001-14
Brake Valve	7001-14
Service Brake Circuit	7001-15
Emergency Braking	7001-18
BRAKE SYSTEM TROUBLESHOOTING.....	7001-19
 SERVICE BRAKE VALVE.....	SECTION 7002 (Book 4 - 87525658)
SPECIAL TORQUE VALUES	7002-2
RECOMMENDED TOOLS	7002-2
SERVICE BRAKE VALVE REMOVAL	7002-3
SERVICE BRAKE VALVE DISASSEMBLY	7002-6
INSPECTION AND CLEANING	7002-8
BRAKE MALFUNCTION SWITCH TEST	7002-8
SERVICE BRAKE VALVE EXPLODED VIEW	7002-9
SERVICE BRAKE VALVE SECTIONAL VIEW	7002-10
SERVICE BRAKE VALVE ASSEMBLY	7002-11
SERVICE BRAKE VALVE INSTALLATION	7002-13
 2006 AND 2007 MODEL YEAR HYDRAULIC SCHEMATIC	POSTER 87522496
2008 MODEL YEAR HYDRAULIC SCHEMATIC	POSTER 87722948

STX AND STEIGER SERIES TRACTORS MASTER TABLE OF CONTENTS

HOW TO READ SYMBOLS IN A HYDRAULIC SCHEMATIC	SECTION 8000 (Book 5 - 87618152)
Introduction	8000-3
Circuit Diagrams	8000-3
Symbol Systems	8000-3
Using Schematic Symbols	8000-3
Reservoirs	8000-3
Lines, Tubes and Hoses	8000-4
Crossing or Joining Lines	8000-5
Pump Symbols	8000-5
Hydraulic Motor Symbols	8000-6
Cylinder Symbols	8000-6
Pressure Control Symbols	8000-7
Normally Closed	8000-7
Normally Open	8000-7
Relief Valve	8000-7
Pressure Reducing Valve	8000-7
Sequence Valve	8000-8
Directional Control Symbols	8000-8
Simplified Symbols	8000-8
One Way Valve	8000-8
By Pass Valve	8000-8
Composite Symbols	8000-8
One Way Valves	8000-8
Two Position Valves	8000-8
Three Position Valves	8000-9
Actuating Controls	8000-9
Flow Control Symbols	8000-9
Restrictors	8000-9
Accessories	8000-10
SIMPLE SCHEMATIC	8000-12
COMMON SYMBOLS	8000-14
Lines and Line Functions	8000-14
Mechanical Devices	8000-14
Pumps and Motors	8000-14
Reservoirs	8000-15
Cylinders	8000-15
Valves	8000-15
Valve Actuators	8000-17
Accessories.....	8000-17
HYDRAULIC SYSTEM HOW IT WORKS WITH TROUBLESHOOTING	SECTION 8001 (Book 5 - 87618152)
GENERAL INTRODUCTION	8001-3
SPECIFICATIONS	8001-5
MODEL NUMBER LOCATION	8001-7
STANDARD AND HIGH FLOW PFC PISTON PUMPS	8001-8
Principle of Control	8001-8
Engine Start Up	8001-8
Operating Modes	8001-8
Low Pressure Standby	8001-8
Pressure and Flow Delivery and Compensation Principle	8001-8
Increased Flow Demand	8001-9
Decreased Flow Demand	8001-9
High Pressure Standby	8001-9
Return to Low Pressure Standby	8001-9
Destroke Valve	8001-9
Model 480 and 530 Tractor Hydraulic Fan Pump And Motor	8001-10
PRESSURE/FLOW COMPENSATED PUMP	8001-12

STX AND STEIGER SERIES TRACTORS MASTER TABLE OF CONTENTS

PFC CHARGE PRESSURE TEST	8001-14
LOW PRESSURE AND HIGH PRESSURE STANDBY TESTS	8001-16
PFC PISTON PUMP FLOW TEST AT REMOTE COUPLERS	8001-17
TWINFLOW PUMP LOW PRESSURE AND HIGH PRESSURE STANDBY TESTS	8001-18
TWINFLOW PFC PISTON PUMP FLOW TEST AT REMOTE COUPLERS	8001-20
REGULATED PRESSURE TEST	8001-21
REGULATED PRESSURE ADJUSTMENT PROCEDURE	8001-22
REGULATED/LUBE PUMP TESTS	8001-23
480 and 530 HYDRAULIC FAN PUMP LOW PRESSURE STANDBY, HIGH PRESSURE AND FLOW TESTS	8001-25
480 and 530 HYDRAULIC FAN MOTOR TEST	8001-27
REGULATED PRESSURE / LUBE CONTROL SYSTEM	8001-28
REGULATOR VALVE	8001-30
480 and 530 HYDRAULIC FAN CIRCUIT	8001-32
480 and 530 HYDRAULIC FAN SYSTEM	8001-33
STEERING PRIORITY VALVE	8001-34
HYDRAULIC GEAR PUMP/PISTON PUMP REMOVE/INSTALL - STX280/330 ACCUSTEER™	SECTION 8003 (Book 5 - 87618152)
SPECIAL TORQUE VALUES	8003-2
RECOMMENDED TOOLS	8003-2
GEAR PUMP REMOVAL	8003-3
GEAR PUMP INSTALLATION	8003-5
PISTON PUMP REMOVAL	8003-7
PISTON PUMP INSTALLATION	8003-11
START-UP PROCEDURE	8003-15
GEAR PUMP REMOVAL AND INSTALLATION - STX380 THROUGH 530 TRACTORS.....	SECTION 8004 (Book 5 - 87618152)
SPECIAL TORQUE VALUES	8004-2
SPECIAL TOOLS	8004-2
GEAR PUMP REMOVAL	8004-3
GEAR PUMP INSTALLATION	8004-5
PFC AXIAL PISTON PUMP REPAIR.....	SECTION 8005 (Book 5 - 87618152)
SPECIFICATIONS	8005-3
SPECIAL TORQUE VALUES	8005-4
PISTON PUMP DISASSEMBLY	8005-5
PRESSURE/FLOW COMPENSATOR DISASSEMBLY	8005-12
PISTON PUMP CLEANING AND INSPECTION	8005-16
PRESSURE/FLOW COMPENSATOR ASSEMBLY EXPLODED VIEW	8005-20
PRESSURE/FLOW COMPENSATOR ASSEMBLY	8005-21
PISTON PUMP ASSEMBLY EXPLODED VIEW	8005-24
PISTON PUMP ASSEMBLY	8005-25
HITCH SYSTEM - HOW IT WORKS.....	SECTION 8006 (Book 5 - 87618152)
THREE POINT HITCH	8006-3
ELECTRONIC HITCH CONTROL	8006-4
Operator Controls and Settings	8006-5
ELECTRONIC HITCH CONTROL SYSTEM FEATURES	8006-7
HITCH CONTROL VALVE	8006-14
General	8006-14
Raise and Lower Solenoids	8006-14
Raise and Lower Pilot Spools	8006-14
Raise Spool	8006-14
Lower Poppet	8006-14
Load Check Ball	8006-14

STX AND STEIGER SERIES TRACTORS MASTER TABLE OF CONTENTS

Manual Raise or Lower Control Pins	8006-14
Overload Relief Valve	8006-14
Neutral Function and Troubleshooting	8006-16
Raise Function and Troubleshooting	8006-18
Raise Function and Troubleshooting	8006-19
Lower Function and Troubleshooting	8006-20
Lower Function and Troubleshooting	8006-21
THREE POINT HITCH VALVE	SECTION 8007 (Book 5 - 87618152)
SPECIAL TORQUE VALUES	8007-2
TPH VALVE REMOVAL	8007-3
TPH VALVE DISASSEMBLY	8007-5
CLEANING AND INSPECTION	8007-9
HITCH VALVE SOLENOID TEST	8007-11
THREE POINT HITCH VALVE	8007-13
TPH VALVE ASSEMBLY	8007-14
TPH VALVE INSTALLATION	8007-18
REMOTE ELECTRONIC HYDRAULIC SYSTEMS - HOW IT WORKS AND TROUBLESHOOTING	SECTION 8008 (Book 5 - 87618152)
REMOTE HYDRAULIC SYSTEM INTRODUCTION	8008-3
REMOTE SYSTEM CONTROLS (ELECTRONIC)	8008-5
Remote Function Control	8008-6
Full Function Position	8008-6
Neutral Lock Position	8008-6
Float Lock-Out Position	8008-7
Non-Detent Raise Position	8008-7
Hydraulic Motor Position	8008-8
Hydraulic Valve Timer Control	8008-9
Variable Flow Control	8008-9
Remote Valve Load Check Valves	8008-10
REMOTE VALVE PROPORTIONAL CURRENT CONTROL (PCC) SOLENOID OPERATION	8008-11
REMOTE VALVE OPERATION (ELECTRONIC)	8008-12
REMOTE VALVE PROBLEMS AND WHERE TO LOOK	8008-20
ELECTRONIC REMOTE VALVE SYSTEM TESTING	8008-21
FAULT CODE RETRIEVAL	8008-21
REGULATED PRESSURE CHECK	8008-24
REMOTE VALVE HIGH PRESSURE TEST	8008-25
REMOTE VALVE PROPORTIONAL SOLENOID CHECK	8008-26
LOW PRESSURE AND HIGH PRESSURE STANDBY TESTS	8008-27
REMOTE VALVE FLOW TEST	8008-29
REMOTE VALVE SIGNAL CHECK AND HITCH SIGNAL CHECK TEST	8008-31
REMOTE VALVE COUPLER TEST	8008-33
LOAD CHECK INSPECTION	8008-34
PFC PISTON PUMP REMOVAL AND INSTALLATION - STX380 THROUGH 530 TRACTORS	SECTION 8009 (Book 5 - 87618152)
SPECIAL TORQUE VALUES	8009-2
SPECIAL TOOLS	8009-2
PISTON PUMP REMOVAL	8009-3
PISTON PUMP INSTALLATION	8009-8
START-UP PROCEDURE	8009-13
AXLE COOLING AND LUBRICATION SYSTEM	SECTION 8010 (Book 5 - 87618152)
AXLE LUBRICATION CIRCUIT	8010-3
TESTING THE AXLE LUBRICATION CIRCUIT	8010-7
Visual Inspection	8010-7

STX AND STEIGER SERIES TRACTORS MASTER TABLE OF CONTENTS

Axle Lubrication Pressure Test	8010-7
Air Flow Test	8010-7
Axle Pressure Test	8010-7
300 SERIES AXLE LUBRICATION CIRCUIT - WITHOUT ACCUSTEER	8010-8
300 SERIES AXLE LUBRICATION CIRCUIT - WITHOUT ACCUSTEER	8010-9
300 SERIES AXLE LUBRICATION CIRCUIT - WITH ACCUSTEER	8010-10
300 SERIES AXLE LUBRICATION CIRCUIT - WITH ACCUSTEER	8010-11
400 SERIES AXLE LUBRICATION CIRCUIT	8010-12
400 SERIES AXLE LUBRICATION CIRCUIT	8010-13
500 SERIES AXLE LUBRICATION CIRCUIT - WHEELED TRACTORS	8010-14
500 SERIES AXLE LUBRICATION CIRCUIT - WHEELED TRACTORS	8010-15
500 SERIES AXLE LUBRICATION CIRCUIT - QUADTRAC TRACTORS	8010-16
500 SERIES AXLE LUBRICATION CIRCUIT - QUADTRAC TRACTORS	8010-17
HYDRAULIC FILTERS	SECTION 8013 (Book 5 - 87618152)
REMOTE AUXILIARY VALVE AND COUPLER REMOVAL, INSTALLATION AND REPAIR	SECTION 8014 (Book 5 - 87618152)
SPECIAL TORQUE VALUES	8014-3
REMOTE AUXILIARY VALVE MANIFOLD SEAL REPLACEMENT	8014-4
REMOTE AUXILIARY VALVE SOLENOID TEST	8014-9
REMOTE AUXILIARY VALVE SOLENOID REMOVAL AND DISASSEMBLY	8014-9
REMOTE AUXILIARY VALVE SOLENOID ASSEMBLY AND INSTALLATION	8014-12
REMOTE AUXILIARY VALVE CONTROL SPOOL REMOVAL	8014-15
REMOTE AUXILIARY VALVE CONTROL SPOOL INSTALLATION	8014-17
REMOTE AUXILIARY VALVE REMOVAL	8014-19
REMOTE AUXILIARY VALVE SECTION DISASSEMBLY	8014-20
LOAD CHECK VALVE DISASSEMBLY	8014-25
REMOTE AUXILIARY VALVE SECTION ASSEMBLY	8014-27
LOAD CHECK VALVE ASSEMBLY	8014-29
REMOTE AUXILIARY VALVE SECTION ASSEMBLY	8014-31
REMOTE AUXILIARY VALVE SECTION INSTALLATION	8014-36
HYD GEAR PUMP/PISTON PUMP REMOVE/INSTALL - STX280/330 STANDARD TRACTOR	SECTION 8015 (Book 5 - 87618152)
SPECIAL TORQUE VALUES	8015-3
RECOMMENDED TOOLS	8015-3
GEAR PUMP REMOVAL	8015-4
GEAR PUMP INSTALLATION	8015-7
PFC PISTON PUMP REMOVAL	8015-9
PFC PISTON PUMP INSTALLATION	8015-14
START-UP PROCEDURE	8015-19
HYDRAULIC GEAR (CHARGE) PUMP REPAIR	SECTION 8017 (Book 5 - 87618152)
SPECIAL TORQUE VALUES	8017-2
PUMP DISASSEMBLY	8017-3
CLEANING AND INSPECTION	8017-7
PUMP ASSEMBLY	8017-8
HYDRAULIC FAN/MOTOR REMOVAL AND FAN MOTOR AND PUMP REPAIR - STX480/530	SECTION 8018 (Book 5 - 87618152)
SPECIAL TORQUE VALUES	8018-3
HYDRAULIC FAN AND FAN MOTOR REMOVAL	8018-4
HYDRAULIC FAN AND FAN MOTOR INSTALLATION	8018-15
HYDRAULIC FAN PUMP REMOVAL	8018-28
HYDRAULIC FAN PUMP INSTALLATION	8018-31
HYDRAULIC FAN MOTOR DISASSEMBLY	8018-35

STX AND STEIGER SERIES TRACTORS MASTER TABLE OF CONTENTS

HYDRAULIC FAN MOTOR ASSEMBLY	8018-39
COMPENSATOR CONTROL VALVE REMOVAL AND DISASSEMBLY	8018-42
COMPENSATOR CONTROL VALVE ASSEMBLY AND INSTALLATION	8018-43
HYDRAULIC FAN PUMP DISASSEMBLY	8018-44
PUMP CLEANING AND INSPECTION	8018-51
AIR CONDITIONER SYSTEM SERVICE	SECTION 9002 (Book 6 - 87525660)
SPECIFICATIONS	9002-4
SPECIAL TORQUES	9002-4
SPECIAL TOOLS	9002-4
SAFETY PROCEDURES	9002-8
AIR CONDITIONER SYSTEM REFRIGERANT RECOVERY	9002-9
RECOVERING PURE 134A REFRIGERANT	9002-11
RECOVERING CONTAMINATED REFRIGERANT WITH OEM1691	9002-15
Preparing the Tank	9002-15
Recovery Process	9002-17
AIR CONDITIONER SYSTEM EVACUATION AND RECHARGING	9002-22
AIR CONDITIONING TEMPERATURE/PRESSURE CHART	9002-27
LEAK DETECTION	9002-28
Electronic Testing with OEM1437	9002-29
Florescent Leak Detection	9002-29
Fluorescent Dye Injection	9002-30
Recovery Station Dye Injector Tool with a System in a Vacuum	9002-30
Recovery Station Dye Injector Tool with a Charged System	9002-31
Quick and Easy Dye Injector Tool with a Charged System	9002-32
Compressor Oil Port	9002-33
SP-20 PAG Oil Return Bottle	9002-34
Fluorescent Leak Testing	9002-35
A/C SYSTEM FLUSHING PROCEDURE	9002-36
Required Tools	9002-37
Precautions	9002-38
Component Flushing Procedure with Power Flush 17550	9002-39
Complete Circuit Flushing Procedure with Power Flush 17550	9002-42
Back Flushing the Thermal Expansion Valve or Refrigerant Line	9002-46
Post Flushing Procedures	9002-48
Flushing Solvent Disposal	9002-49
A/C SYSTEM COMPONENTS	9002-50
Cab HVAC Box Components - Automatic Temperature Control	9002-50
280/330 Chassis Components	9002-51
380/430/480/530 Chassis Components	9002-53
A/C COMPRESSOR CLUTCH	9002-55
Clutch Removal	9002-55
Exploded View of Clutch	9002-58
Compressor Clutch Replacement	9002-59
A/C COMPRESSOR	9002-63
Oil Level Check or Adjustment	9002-63
Injection Method	9002-63
Dipstick Method	9002-64
Compressor Removal - 280/330	9002-66
Compressor Installation - 280/330	9002-68
Compressor Removal - 380/430/480/530	9002-70
Compressor Installation - 380/430/480/530	9002-71
Compressor Belt Installation and Adjustment - 280/330	9002-72
THERMAL EXPANSION VALVE TESTING	9002-73
THERMAL EXPANSION VALVE REPLACEMENT	9002-74
CONDENSER AND RECEIVER-DRIER	9002-75
ACCESSING THE HVAC BOX	9002-76

STX AND STEIGER SERIES TRACTORS MASTER TABLE OF CONTENTS

EVAPORATOR TEMPERATURE SENSOR LOCATION	9002-77
BLOWER MOTOR REPLACEMENT	9002-78
HEATER CONTROL VALVE REPLACEMENT	9002-78
EVAPORATOR/HEATER ASSEMBLY	9002-79
Evaporator/Heater Assembly Removal	9002-79
Evaporator/Heater Assembly Installation	9002-82
Post Replacement Procedures	9002-84
EVAPORATOR/HEATER ASSEMBLY SEALING AND CLEANING	9002-85
BLOWER AND EVAPORATOR REFERENCE ILLUSTRATION	9002-86
ATC CONTROLLER, BLOWER DRIVER & STANDARD A/C CONTROLLER REPLACEMENT	9002-87
ACCESSING AND REPLACING THE MODE DOOR MOTOR	9002-88
CAB INTAKE AIR FILTER SERVICE	9002-91
CAB RECIRCULATION AIR FILTER SERVICE	9002-92
CAB PRESSURIZATION TEST	9002-93
CAB PRESSURIZER MOTOR REPLACEMENT	9002-95
VISCOUS FAN DRIVE	9002-95
AIR CONDITIONING SYSTEM -TROUBLESHOOTING	SECTION 9003 (Book 6 - 87525660)
SAFETY PROCEDURES	9003-4
SPECIAL TOOLS	9003-5
A/C THERMAL OPERATION	9003-6
A/C SYSTEM COMPONENTS	9003-8
Cab HVAC Box Components - Automatic Temperature Control	9003-8
280/330 Chassis Components	9003-10
380/430/480/530 Chassis Components	9003-12
AUTOMATIC TEMPERATURE CONTROL (ATC) OPERATION	9003-14
ATC FAULT CODES	9003-21
ATC Fault Code 111	9003-21
ATC Fault Code 112	9003-22
ATC Fault Code 115	9003-22
ATC Fault Code 116	9003-23
ATC Fault Code 120	9003-23
ATC Fault Code 121	9003-24
ATC Fault Code 122	9003-24
ATC Fault Code 125	9003-25
ATC Fault Code 126	9003-25
ATC Fault Code 127	9003-26
ATC Fault Code 128	9003-26
ATC Fault Code 129	9003-27
ATC Fault Code 130	9003-27
ATC Fault Code 131	9003-28
ATC Fault Code 132	9003-28
ATC Fault Code 133	9003-29
ATC Fault Code 134	9003-30
LOCATING SYSTEM PROBLEMS WITHOUT FAULT CODES	9003-31
Controller-Based Resistance Tests	9003-31
ATC CONTROLLER TEST (CONNECTOR J8 TEST POINTS)	9003-33
FIELD REPORTED SYMPTOMS/CAUSES	9003-36
COMPRESSOR AND CLUTCH	9003-37
Operational Check	9003-37
Electrical Test	9003-41
Compressor Clutch Control Circuit Test Procedure	9003-41
HIGH AND LOW PRESSURE SWITCH CLUTCH LATCHING CIRCUIT	9003-44
Electrical Test	9003-46
High Pressure Switch and Circuit Test	9003-46
Low Pressure Switch and Circuit Test	9003-47
HEATER CONTROL VALVE	9003-48

STX AND STEIGER SERIES TRACTORS MASTER TABLE OF CONTENTS

Operational Check	9003-48
Electrical Test	9003-49
Heater Control Valve Power, Signal and Ground Test	9003-49
BLOWER SPEED, TEMPERATURE CONTROL AND MODE DOOR POTS	9003-50
Electrical Test	9003-51
Common Control Potentiometer and Circuit Test Procedure	9003-51
BLOWER AND BLOWER SPEED DRIVER	9003-52
Blower Motor/Blower Driver Power, Signal and Ground Test	9003-53
MODE DOOR CONTROL AND MOTOR	9003-54
Electrical Test	9003-55
Mode Door Motor and Circuit Test	9003-55
CAB AND EVAPORATOR TEMPERATURE SENSORS	9003-56
Electrical Test	9003-57
Cab Temperature Sensor and Circuit Test	9003-59
Evaporator Temperature Sensor and Circuit Test	9003-60
CONTROLLER POWER AND GROUND, ATC SWITCH	9003-62
Controller Power Supply and Ground Test	9003-62
ATC Switch and Circuit Test	9003-63
Defog/Defrost Switch and Circuit Test	9003-63
CAB PRESSURIZER BLOWER	9003-64
Cab Pressurizer Blower & Relay Power Supply and Ground Test	9003-64
ACCESSING THE HVAC BOX	9003-65
AIR CONDITIONING SYSTEM -TROUBLESHOOTING	
For Steiger Models 335, 385, 435, 485, and 535	SECTION 9004 (Book 6A - 87740905)
SAFETY PROCEDURES	9004-4
SPECIAL TOOLS	9004-5
A/C THERMAL OPERATION	9004-6
A/C SYSTEM COMPONENTS	9004-8
Cab HVAC Box Components - Automatic Temperature Control	9004-8
335 Chassis Components	9004-10
385/435/485 Chassis Components	9004-12
535 Chassis Components	9004-13
AUTOMATIC TEMPERATURE CONTROL (ATC) OPERATION	9004-15
ATC FAULT CODES	9004-22
ATC Fault Code 111	9004-22
ATC Fault Code 112	9004-23
ATC Fault Code 115	9004-23
ATC Fault Code 116	9004-24
ATC Fault Code 120	9004-24
ATC Fault Code 121	9004-25
ATC Fault Code 122	9004-25
ATC Fault Code 125	9004-26
ATC Fault Code 126	9004-26
ATC Fault Code 127	9004-27
ATC Fault Code 128	9004-27
ATC Fault Code 129	9004-28
ATC Fault Code 130	9004-28
ATC Fault Code 131	9004-29
ATC Fault Code 132	9004-29
ATC Fault Code 133	9004-30
ATC Fault Code 134	9004-31
LOCATING SYSTEM PROBLEMS WITHOUT FAULT CODES	9004-32
Controller-Based Resistance Tests	9004-32
ATC CONTROLLER TEST (CONNECTOR J8 TEST POINTS)	9004-34
FIELD REPORTED SYMPTOMS/CAUSES	9004-37
COMPRESSOR AND CLUTCH	9004-38

STX AND STEIGER SERIES TRACTORS MASTER TABLE OF CONTENTS

Operational Check	9004-38
Electrical Test	9004-43
Compressor Clutch Control Circuit Test Procedure	9004-43
HIGH AND LOW PRESSURE SWITCH CLUTCH LATCHING CIRCUIT	9004-46
Electrical Test	9004-48
High Pressure Switch and Circuit Test	9004-48
Low Pressure Switch and Circuit Test	9004-49
HEATER CONTROL VALVE	9004-50
Operational Check	9004-50
Electrical Test	9004-51
Heater Control Valve Power, Signal and Ground Test	9004-51
BLOWER SPEED, TEMPERATURE CONTROL AND MODE DOOR POTS	9004-52
Electrical Test	9004-53
Common Control Potentiometer and Circuit Test Procedure	9004-53
BLOWER AND BLOWER SPEED DRIVER	9004-54
Blower Motor/Blower Driver Power, Signal and Ground Test	9004-55
MODE DOOR CONTROL AND MOTOR	9004-56
Electrical Test	9004-57
Mode Door Motor and Circuit Test	9004-57
CAB AND EVAPORATOR TEMPERATURE SENSORS	9004-58
Electrical Test	9004-59
Cab Temperature Sensor and Circuit Test	9004-61
Evaporator Temperature Sensor and Circuit Test	9004-62
CONTROLLER POWER AND GROUND, ATC SWITCH	9004-64
Controller Power Supply and Ground Test	9004-64
ATC Switch and Circuit Test	9004-65
Defog/Defrost Switch and Circuit Test	9004-65
CAB PRESSURIZER BLOWER	9004-66
Cab Pressurizer Blower & Relay Power Supply and Ground Test	9004-66
ACCESSING THE HVAC BOX	9004-67
CAB REMOVAL - STX280/330 TRACTORS.....	SECTION 9005 (Book 6 - 87525660)
SPECIAL TOOLS	9005-3
SPECIAL TORQUE VALUES	9005-3
CAB REMOVAL	9005-4
CAB INSTALLATION	9005-11
CAB REMOVAL - STX380 THROUGH 530 TRACTORS	SECTION 9006 (Book 6 - 87525660)
SPECIAL TOOLS	9006-3
SPECIAL TORQUE VALUES	9006-3
CAB REMOVAL	9006-4
CAB INSTALLATION	9006-13
HOOD REMOVAL AND INSTALLATION - STX380/430 TRACTORS	SECTION 9007 (Book 6 - 87525660)
SPECIAL TORQUE VALUES	9007-2
RECOMMENDED TOOLS	9007-2
HOOD REMOVAL	9007-3
HOOD INSTALLATION	9007-6
RADIATOR, COOLERS AND CONDENSER REMOVAL/INSTALL - STX380/430 TRACTORS.....	SECTION 9008 (Book 6 - 87525660)
SPECIAL TORQUE VALUES	9008-2
GENERAL INFORMATION	9008-3
ENGINE AIR TO AIR COOLER REMOVAL	9008-4
AIR TO AIR COOLER INSTALLATION	9008-6
A/C CONDENSER REMOVAL	9008-7
A/C CONDENSER INSTALLATION	9008-8

STX AND STEIGER SERIES TRACTORS MASTER TABLE OF CONTENTS

HYDRAULIC/TRANSMISSION OIL COOLER REMOVAL	9008-10	
HYDRAULIC/TRANSMISSION OIL COOLER INSTALLATION	9008-12	
RADIATOR AND COOLER ASSEMBLY REMOVAL	9008-15	
CENTER HINGE BEARINGS & CONNECTING LINK -		
STX380 THROUGH 530 AND QUADTRAC	SECTION 9010 (Book 6 - 87525660)	
SPECIAL TORQUE VALUES	9010-3	
SPECIAL TOOL	9010-3	
RECOMMENDED TOOLS	9010-3	
GENERAL INFORMATION	9010-5	
SEPARATING THE FRONT AND REAR FRAMES	9010-5	
BOTTOM HINGE BEARING REPLACEMENT	9010-11	
CONNECTING LINK FRONT BUSHING REPLACEMENT	9010-19	
CONNECTING LINK REMOVAL	9010-21	
CONNECTING LINK REAR BEARING REPLACEMENT	9010-22	
CONNECTING LINK INSTALLATION	9010-23	
CONNECTING THE FRONT AND REAR FRAMES	9010-25	
DRAWBAR REMOVAL AND INSTALLATION		SECTION 9013 (Book 6 - 87525660)
SPECIAL TORQUE VALUES	9013-2	
SPECIAL TOOLS	9013-2	
DRAWBAR REMOVAL	9013-3	
DRAWBAR INSTALLATION	9013-7	
FRONT FRAME HINGE AND BEARING -		
STX280/330 ACCUSTEER™ TRACTORS	SECTION 9014 (Book 6 - 87525660)	
SPECIAL TORQUE VALUES	9014-3	
SPECIAL TOOLS	9014-3	
RECOMMENDED TOOLS	9014-4	
SEPARATING THE FRONT FRAME FROM THE CENTER FRAME	9014-5	
FRONT BOTTOM HINGE BEARING REPLACEMENT	9014-16	
FRONT UPPER BEARING REMOVAL AND INSTALLATION	9014-19	
CONNECTING THE FRONT AND REAR FRAMES	9014-20	
CAB TOP REMOVAL AND INSTALLATION		SECTION 9015 (Book 6 - 87525660)
CAB TOP REMOVAL	9015-3	
CAB TOP INSTALLATION	9015-5	
HOOD REMOVAL AND INSTALLATION -		
480/530 and 485/535 TRACTORS	SECTION 9016 (Book 6A - 87740905)	
SPECIAL TORQUE VALUES	9016-2	
RECOMMENDED TOOLS	9016-2	
HOOD REMOVAL	9016-3	
HOOD INSTALLATION	9016-5	
HOOD REMOVAL AND INSTALLATION - STX280/330 TRACTORS		SECTION 9017 (Book 6 - 87525660)
SPECIAL TORQUE VALUES	9017-2	
RECOMMENDED TOOLS	9017-2	
HOOD REMOVAL	9017-3	
HOOD INSTALLATION	9017-5	
RADIATOR, COOLERS AND CONDENSER REMOVE/INSTALL -		
STX480/530 TRACTORS	SECTION 9018 (Book 6 - 87525660)	
SPECIAL TORQUE VALUES	9018-3	
GENERAL INFORMATION	9018-3	
FUEL COOLER REMOVAL	9018-4	
FUEL COOLER INSTALLATION	9018-4	

STX AND STEIGER SERIES TRACTORS MASTER TABLE OF CONTENTS

ENGINE AIR TO AIR COOLER REMOVAL	9018-5
ENGINE AIR TO AIR COOLER INSTALLATION	9018-7
A/C CONDENSER AND HYDRAULIC FAN COOLER REMOVAL	9018-9
A/C CONDENSER AND HYDRAULIC FAN COOLER INSTALLATION	9018-10
RADIATOR AND COOLER ASSEMBLY REMOVAL	9018-12
RADIATOR/COOLER DISASSEMBLY	9018-19
RADIATOR, COOLERS AND CONDENSER REMOVE/INSTALL - STX280/330 TRACTORS.....	SECTION 9019 (Book 6 - 87525660)
SPECIAL TORQUE VALUES	9019-2
GENERAL INFORMATION	9019-3
FUEL COOLER REMOVAL	9019-3
FUEL COOLER INSTALLATION	9019-4
ENGINE AIR TO AIR COOLER REMOVAL	9019-6
AIR TO AIR COOLER INSTALLATION	9019-9
A/C CONDENSER REMOVAL	9019-12
A/C CONDENSER INSTALLATION	9019-13
HYDRAULIC/TRANSMISSION OIL COOLER REMOVAL	9019-15
HYDRAULIC/TRANSMISSION OIL COOLER INSTALLATION	9019-17
RADIATOR AND COOLER ASSEMBLY REMOVAL	9019-20
RADIATOR AND COOLER ASSEMBLY INSTALLATION	9019-27
CENTER HINGE BEARINGS AND CONNECTING LINK - STX280/330 TRACTORS.....	SECTION 9020 (Book 6 - 87525660)
SPECIAL TORQUE VALUES	9020-3
SPECIAL TOOL	9020-3
RECOMMENDED TOOLS	9020-3
GENERAL INFORMATION	9020-5
SEPARATING THE FRONT AND REAR FRAMES	9020-5
BOTTOM HINGE BEARING REPLACEMENT	9020-11
CONNECTING LINK FRONT BUSHING REPLACEMENT	9020-19
CONNECTING LINK REMOVAL	9020-21
CONNECTING LINK REAR BEARING REPLACEMENT	9020-22
CONNECTING LINK INSTALLATION	9020-23
CONNECTING THE FRONT AND REAR FRAMES	9020-25
CAB REMOVAL Steiger 385, 435, 485 And 535 Tractors.....	SECTION 9021 (Book 6A - 87740905)
SPECIAL TOOLS	9021-3
SPECIAL TORQUE VALUES	9021-3
CAB REMOVAL	9021-4
General Information	9021-4
CAB INSTALLATION	9021-15
CENTER HINGE BEARINGS AND CONNECTING LINK Steiger 385 through 535 Wheel And QUADTRAC Tractors.....	SECTION 9022 (Book 6A - 87740905)
SPECIAL TORQUE VALUES	9022-3
SPECIAL TOOL	9022-3
RECOMMENDED TOOLS	9022-3
GENERAL INFORMATION	9022-5
SEPARATING THE FRONT AND REAR FRAMES	9022-5
BOTTOM HINGE BEARING REPLACEMENT	9022-12
CONNECTING LINK FRONT BUSHING REPLACEMENT	9022-20
CONNECTING LINK REMOVAL	9022-22
CONNECTING LINK REAR BEARING REPLACEMENT	9022-23
CONNECTING LINK INSTALLATION	9022-24
CONNECTING THE FRONT AND REAR FRAMES	9022-26

STX AND STEIGER SERIES TRACTORS MASTER TABLE OF CONTENTS

RADIATOR, COOLERS AND CONDENSER REMOVE AND INSTALL

Steiger 485	SECTION 9023 (Book 6A - 87740905)
SPECIAL TORQUE VALUES	9023-3
ENGINE AIR TO AIR COOLER REMOVAL	9023-4
ENGINE AIR TO AIR COOLER INSTALLATION	9023-6
A/C CONDENSER AND HYDRAULIC FAN COOLER REMOVAL	9023-8
A/C CONDENSER AND HYDRAULIC FAN COOLER INSTALLATION	9023-9
RADIATOR AND COOLER ASSEMBLY REMOVAL	9023-11
RADIATOR/COOLER DISASSEMBLY	9023-18

ELECTRONIC CONTROLLER CONFIG, CALIBRATION AND FAULT CODE RETRIVAL

STX and Steiger 280, 330, 380, 430, 480, and 530	SECTION 10001 (Book 7 - 87525661)
INSTRUMENTATION PROGRAMMING	10001-3
Operation Setup	10001-3
Unit of Measure	10001-4
Tire Radius	10001-4
Radar Calibration	10001-7
Controller Configuration	10001-10
ARMREST CONTROLLER CALIBRATION	10001-15
Hitch Menu	10001-16
Throttle Menu	10001-18
Remote Valve Menu	10001-18
TRANSMISSION CONTROLLER CALIBRATION	10001-23
Trans View Mode	10001-25
Trans Setup Mode	10001-33
Clutch Calibration Procedure	10001-35
Calibration Error Messages	10001-40
Gear Default Mode	10001-41
HITCH CONTROLLER CALIBRATION	10001-43
Hitch Setting Menu	10001-49
Hitch View Menu	10001-51
REMOTE HYDRAULICS CONTROLLER CALIBRATION	10001-52
Aux Setup Menu	10001-57
Aux Calibration Menu	10001-58
Aux 67 Mode Lever Menu	10001-72
STEERING CONTROLLER CALIBRATION	10001-74
STEER TEST Menu	10001-85
FAULT CODE RETRIEVAL	10001-89

ELECTRONIC CONTROLLER CONFIGURATION, CALIBRATION AND FAULT CODE RETRIEVAL

Steiger 335, 385, 435, 485, and 535 Series Tractors	SECTION 10001A (Book 6A - 87740905)
STRUMENTATION PROGRAMMING	10001A-3
Operation Setup	10001A-3
Unit of Measure	10001A-4
Tire Radius	10001A-4
Radar Calibration	10001A-7
Controller Configuration	10001A-10
ARMREST CONTROLLER CALIBRATION	10001A-15
Hitch Menu	10001A-16
Throttle Menu	10001A-19
Remote Valve Menu	10001A-19
Exit Calibration	10001A-25
TRANSMISSION CONTROLLER CALIBRATION	10001A-26
Trans Vieww Mode	10001A-28
Trans Setup Mode	10001A-36
Clutch Calibration Procedure	10001A-39
Calibration Error Messages	10001A-44

STX AND STEIGER SERIES TRACTORS MASTER TABLE OF CONTENTS

Gear Default Mode	10001A-45
HITCH CONTROLLER CALIBRATION	10001A-47
Hitch Setting Menu	10001A-53
Hitch View Menu	10001A-55
REMOTE HYDRAULICS CONTROLLER CALIBRATION	10001A-56
Aux Setup Menu	10001A-61
Aux Calibration Menu	10001A-62
Aux 67 Mode Lever Menu	10001A-76
STEERING CONTROLLER CALIBRATION	10001A-78
STEER TEST Menu	10001A-89
FAULT CODE RETRIEVAL	10001A-93
HITCH CONTROLLER FAULT CODES.....	SECTION 10002 (Book 7 - 87525661)
FAULT CODE HITCH 1020	10002-5
FAULT CODE HITCH 1030	10002-6
FAULT CODE HITCH 3010	10002-7
FAULT CODE HITCH 3020	10002-9
FAULT CODE HITCH 3030	10002-10
FAULT CODE HITCH 4019	10002-11
FAULT CODE HITCH 4029	10002-12
FAULT CODE HITCH 4039	10002-13
FAULT CODE HITCH 4049	10002-14
FAULT CODE HITCH 6014	10002-15
FAULT CODE HITCH 6015	10002-16
FAULT CODE HITCH 6024	10002-17
FAULT CODE HITCH 6025	10002-18
FAULT CODE HITCH 8001	10002-19
FAULT CODE HITCH 8002	10002-20
FAULT CODE HITCH 9301	10002-21
FAULT CODE HITCH 9302	10002-22
FAULT CODE HITCH 9303	10002-23
FAULT CODE HITCH 9304	10002-24
FAULT CODE HITCH 9306	10002-25
FAULT CODE HITCH 9307	10002-26
FAULT CODE HITCH 9308	10002-27
FAULT CODE HITCH 9309	10002-28
FAULT CODE HITCH 9310	10002-29
FAULT CODE HITCH 9311	10002-30
FAULT CODE HITCH 9312	10002-31
FAULT CODE HITCH 9313	10002-32
FAULT CODE HITCH 9314	10002-33
FAULT CODE HITCH 9315	10002-34
FAULT CODE HITCH 9316	10002-35
FAULT CODE HITCH 9317	10002-36
FAULT CODE HITCH 9318	10002-37
FAULT CODE HITCH 9319	10002-38
FAULT CODE HITCH 9320	10002-39
FAULT CODE HITCH 9321	10002-40
FAULT CODE HITCH 10030	10002-41
FAULT CODE HITCH 10060	10002-42
FAULT CODE HITCH 10061	10002-43
FAULT CODE HITCH 10071	10002-44
FAULT CODE HITCH 10072	10002-45
FAULT CODE HITCH 10090	10002-46
FAULT CODE HITCH 11010	10002-47
FAULT CODE HITCH 11020	10002-48
FAULT CODE HITCH 11030	10002-49

Section 1001

SAFETY

SAFETY



WARNING: THIS SAFETY ALERT SYMBOL INDICATES IMPORTANT SAFETY MESSAGES IN THIS MANUAL. WHEN YOU SEE THIS SYMBOL, CAREFULLY READ THE MESSAGE THAT FOLLOWS AND BE ALERT TO THE POSSIBILITY OF PERSONAL INJURY OR DEATH.**

M171B

To prevent injury always follow the Warning, Caution and Danger notes in this section and throughout the manual.

Put the “Do Not Operate” tag shown below on the key for the key switch when keys are removed for servicing or repairing the machine. Tags are available from your service parts supplier.

Before servicing a machine, park the machine on hard level ground. Turn off the engine, apply the parking brake and remove the key from the key switch. Put blocks in front of and behind either the front or rear wheels.



MS99B001



WARNING: Before starting engine study Operators Manual safety messages. Read all safety signs on machine. Clear the area of other persons. Learn and practice safe use of controls before operating. It is your responsibility to understand and follow manufacturers instructions on machine operation, service, and to observe pertinent laws and regulations. Operator and Service Manuals may be obtained from your equipment dealer.

M103A



WARNING: If you wear clothing that is too loose or do not use the correct safety equipment for your job, you can be injured. Always wear clothing that will not catch on objects. Extra safety equipment that can be required includes hard hat, safety shoes, ear protection, eye or face protection, heavy gloves and reflector clothing.

M492



WARNING: When working in the area of the fan belt with the engine running, avoid loose clothing if possible, and use extreme caution.

M493



WARNING: When doing checks and tests on the equipment hydraulics, follow the procedures as they are written. DO NOT change the procedure.

M494



WARNING: When putting the hydraulic cylinders on this machine through the necessary cycles to check operation or to remove air from a circuit, make sure all people are out of the way.

M495



WARNING: Always wear heat protective gloves to prevent burning your hands when handling heated parts.

SM121A



WARNING: Read the operators manual to familiarize yourself with the correct control functions.

M489



WARNING: Operate the machine and equipment controls from the seat position only. Any other method could result in serious injury.

M490



WARNING: This is one man machine, no riders allowed.

M491



WARNING: Lower all attachments to the ground or use stands to safely support the attachments before you do any maintenance or service.

M496



WARNING: Hydraulic oil or diesel fuel leaking under pressure can penetrate the skin and cause infection or other injury.

To Prevent Personal Injury:

Relieve all pressure, before disconnecting fluid lines. Before applying pressure, make sure all connections are tight and components are in good condition.

Never use your hand to check for suspected leaks under pressure.

Use a piece of cardboard or wood for this purpose. If injured by leaking fluid, see your doctor immediately.

SM171A



WARNING: When removing hardened pins such as a pivot pin, or a hardened shaft, use a soft head (brass or bronze) hammer or use a driver made from brass or bronze and a steel head hammer.

M497



WARNING: When using a hammer to remove and install pivot pins or separate parts using compressed air or using a grinder, wear eye protection that completely encloses the eyes (approved goggles or other approved eye protectors).

M498



WARNING: Use suitable floor (service) jacks or chain hoist to raise wheels or tracks off the floor. Always block machine in place with suitable safety stands

M499



WARNING: When servicing or repairing the machine. Keep the shop floor and operators compartment and steps free of oil, water, grease, tools, etc. Use an oil absorbing material and or shop cloths as required. Use safe practices at all times.

M500



WARNING: Some components of this machine are very heavy. Use suitable lifting equipment or additional help as instructed in the Service Manual.

M501



WARNING: Engine exhaust fumes can cause death. If it is necessary to start the engine in a closed place, remove the exhaust fumes from the area with an exhaust pipe extension. Open the door and get outside air into the area.

M502



WARNING: When the battery electrolyte is frozen, the battery can explode if (1), you try to charge the battery, or (2), you try to jump start and run the engine. To prevent the battery electrolyte from freezing, try to keep the battery at full charge. If you do not follow these instructions, you or others in the area can be injured.

M503



WARNING: Batteries contain acid and explosive gas. Explosions can result from sparks, flames or wrong cable connections. To connect the jumper cables correctly to the battery of this machine see the Operators Manual. Failure to follow these instructions can cause serious injury or death.

M504

ROLL OVER PROTECTIVE STRUCTURE (ROPS)

ROPS, the operators seat, the seat belts and all mounting, accessories and wiring inside the operators protective system must be carefully checked after a tractor accident and all parts with damage must be replaced immediately. DO NOT TRY TO MAKE REPAIRS OR WELD THE ROPS.

Safety Rules:

1. Do not make modifications to the ROPS. Example, welding an accessory to the ROPS or drilling a hole in the ROPS.
2. Special fasteners are used to install the operator protective parts. Replacement parts must be the same as given in the Parts Catalog.

Section 2001

ENGINE REMOVAL AND INSTALLATION

ENGINE REMOVAL

STEP 1

1. Park the tractor on a hard level surface.
2. Place the shift lever in PARK (Powershift) or place the shift levers in neutral.
3. Shut off the engine and remove the key from the switch.
4. If necessary, drain the oil from the engine crankcase.

STEP 2

See Hood Removal And Installation 380/430 for instructions to remove the hood from the tractor.

STEP 3

See A/C Component Service for instructions to discharge the air conditioning system.

STEP 4

See Radiator, Coolers And Condenser Removal And Installation 380/430 for instructions to drain and remove the radiator and cooler assembly.

STEP 5

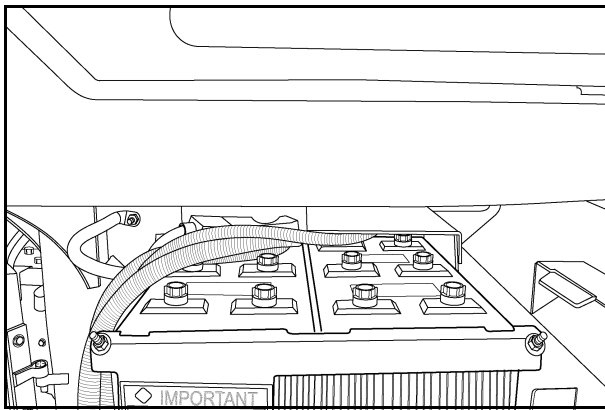

MD05M069

Open the battery access door and remove the negative battery cables from the three batteries.

STEP 6

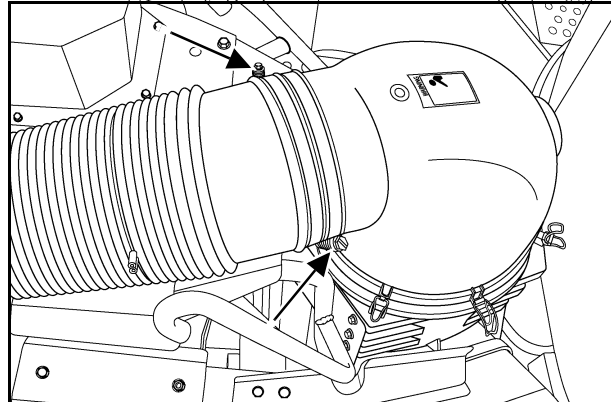

MD05N084

Loosen the air cleaner outlet flex tube clamps.

STEP 7

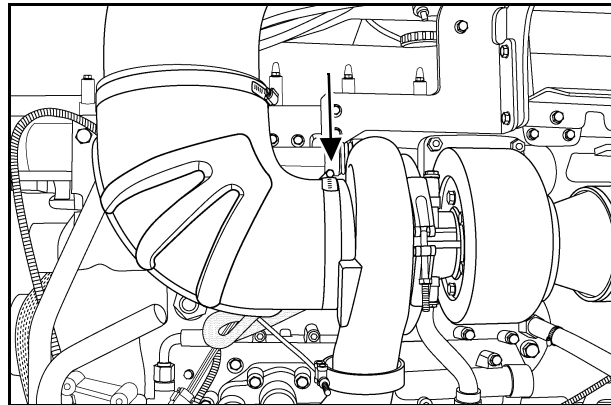

MD05N086

Loosen the turbo inlet elbow clamp.

STEP 8

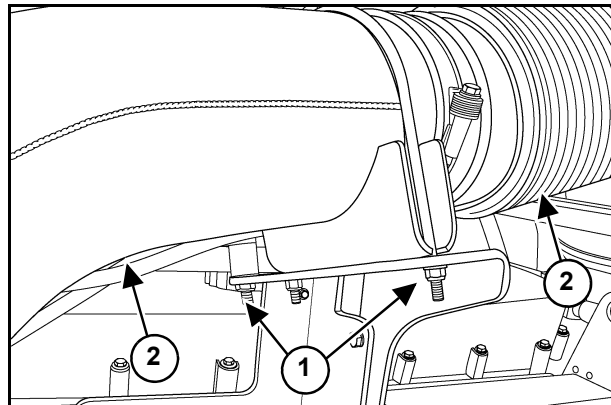

MD05N085

Remove the U-clamp (1) from the air cleaner to turbo inlet tube assembly (2). Remove the assembly from the tractor.

STEP 9

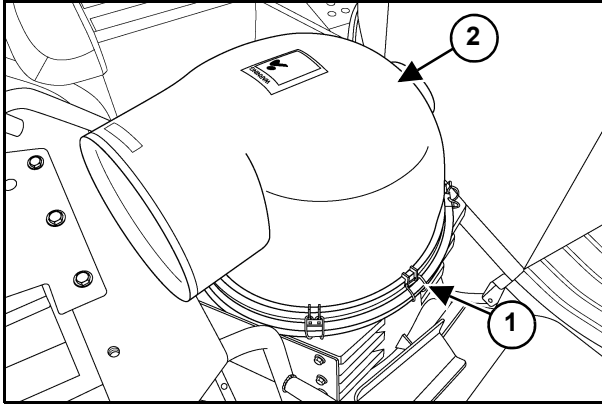

MD05N087

Open the six latches (1) and remove the air cleaner cover (2) and air filter.

STEP 12

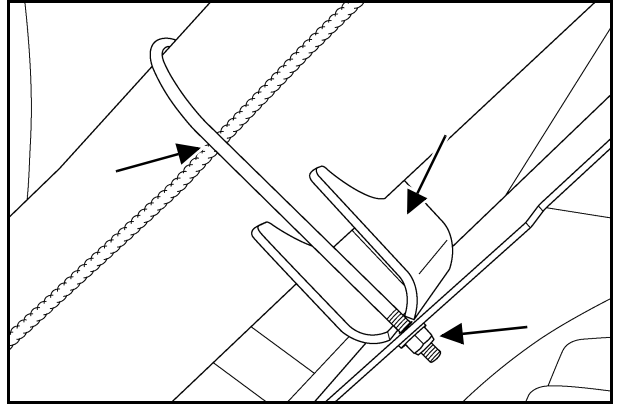

MD05N090

Remove the exhaust pipe U-clamp assembly.

STEP 10

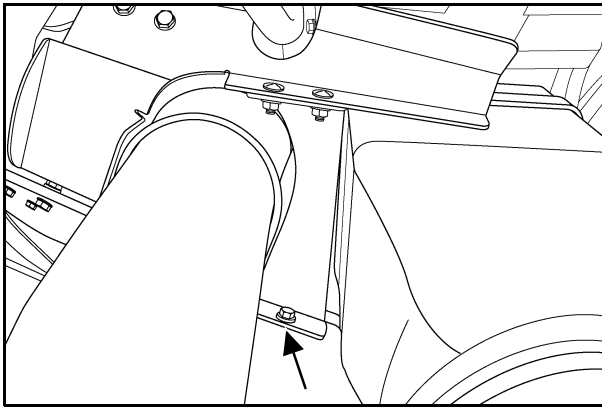

MD05N089

Remove the heat shield rear mounting bolt.

STEP 13

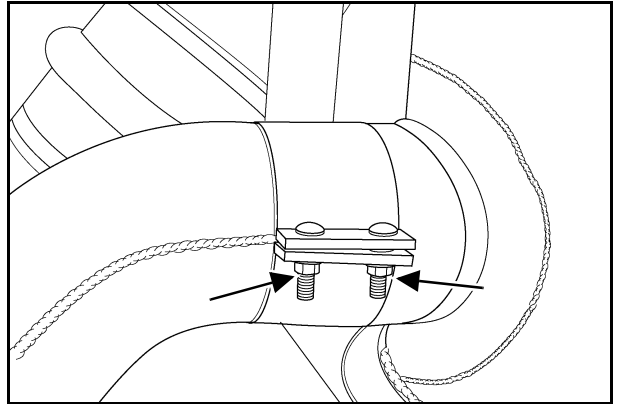

MD05N092

Loosen the exhaust pipe band clamp.

STEP 11

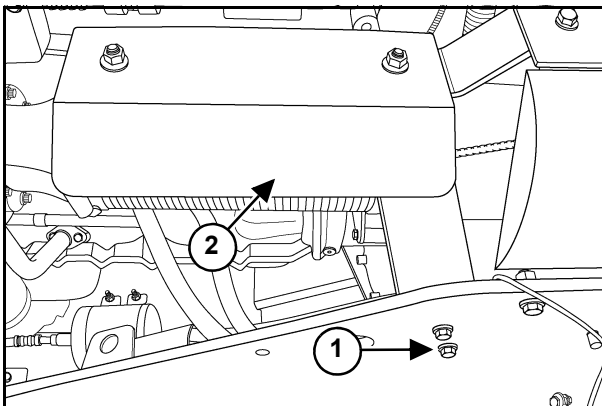

MD05N088

Remove the heat shield two front mounting bolts (1) and nuts. Remove the heat shield assembly (2).

STEP 14

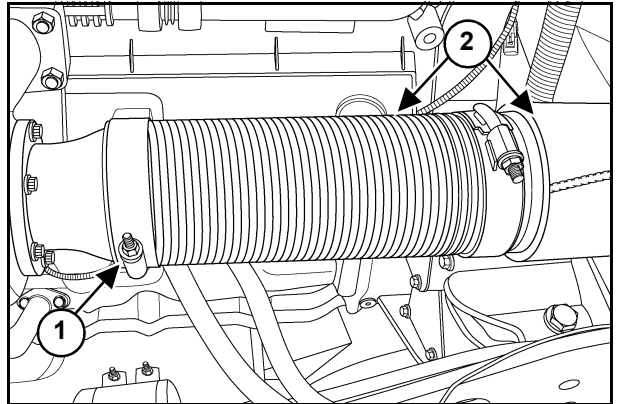

MD05N091

Loosen the turbo exhaust flex tube clamp (1) and remove the flex tube/exhaust pipe assembly (2).

STEP 15

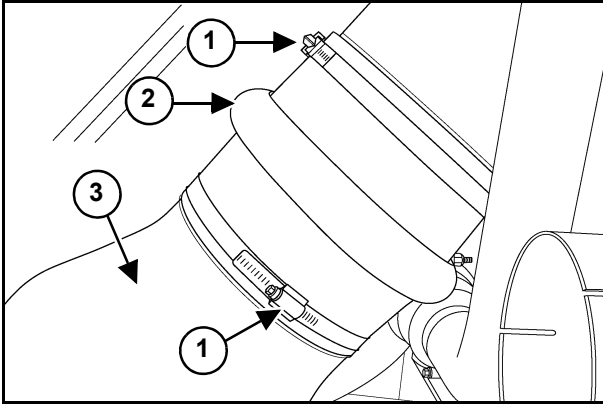

MD05N093

Loosen the air cleaner inlet coupler clamps (1) and move the coupler (2) up and off the air cleaner housing (3).

STEP 16

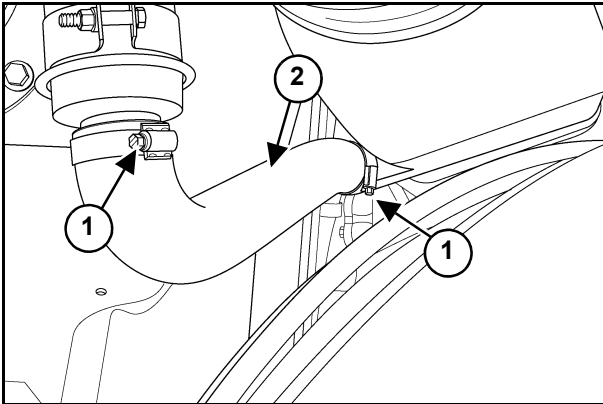

MD05N095

Loosen the hose clamps (1) and remove the aspirator tube (2) from the check valve and air cleaner housing.

STEP 17

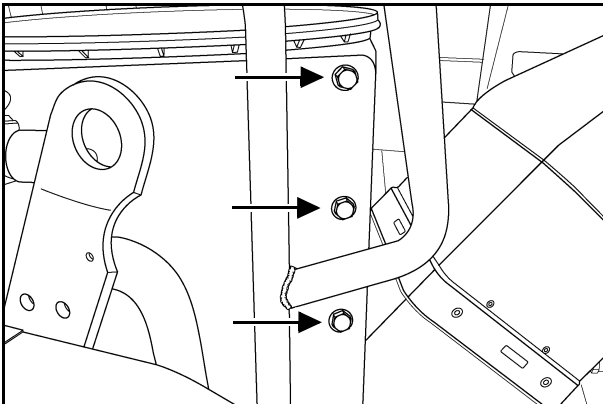

MD05N094

Remove the three RH and three LH air cleaner mounting bolts and remove the air cleaner housing.

STEP 18

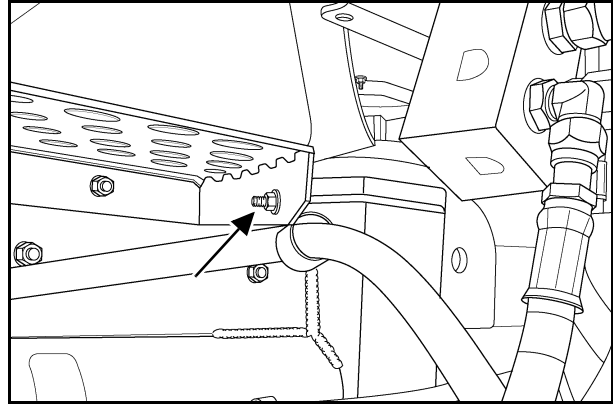

MD05N097

Remove the bolt, washers and nut from the P-clamp on the rear of the RH inside frame platform.

STEP 19

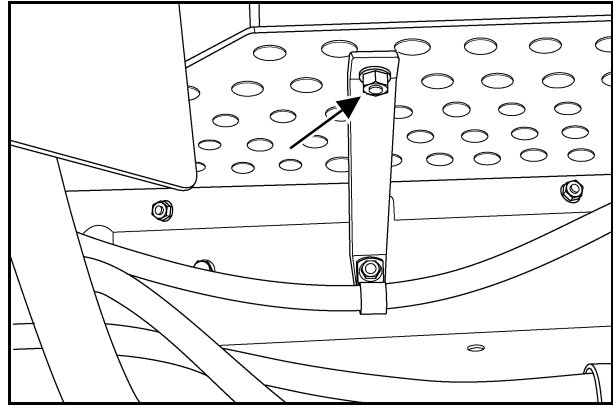

MD05N098

Remove the nut from the platform brace carriage bolt.

STEP 20

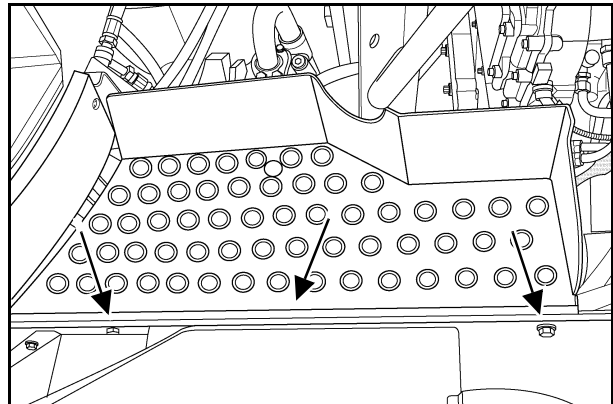

MD05N096

Remove the three platform to frame mounting bolts, washers and nuts. Remove the platform from the tractor.

STEP 21

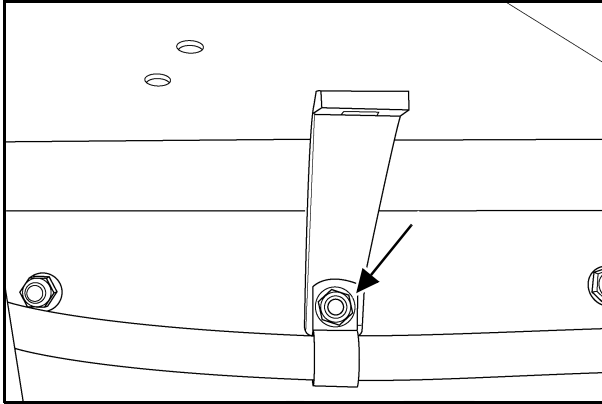

MD05N102

Remove the nut bolt and washer and remove the platform brace.

NOTE: *It is not necessary to remove the brace to remove the engine, but it will allow easier access to other components.*

STEP 22

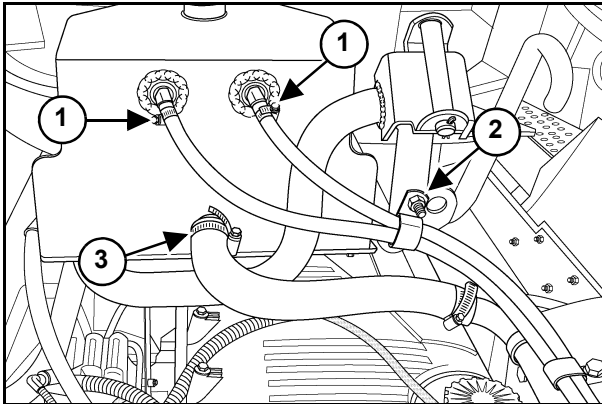

MD05N103

Remove the two deaeration hoses (1) from the tank and remove the P-clamp (2) from the hood support frame.

Remove the make up hose (3) from the tank.

STEP 23

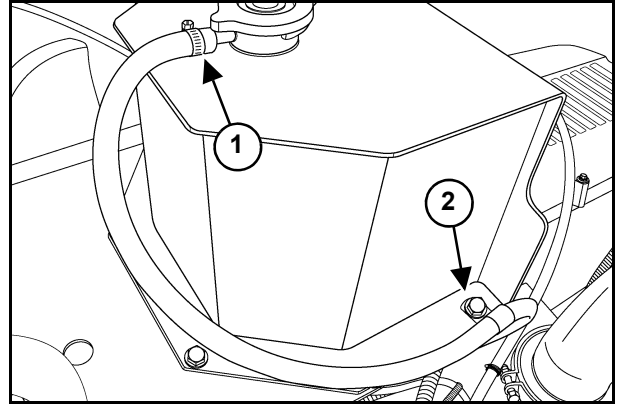

MD05N056

Remove the overflow hose (1) from the deaeration tank. Remove the hose P-clamp (2) from the tank base.

STEP 24

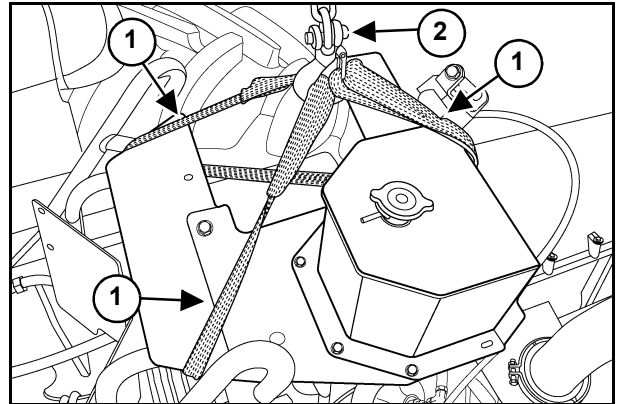

MD05N105

Install lifting straps (1) on the hood support assembly as shown. Attach the straps to an overhead hoist (2) and support the assembly.

STEP 25

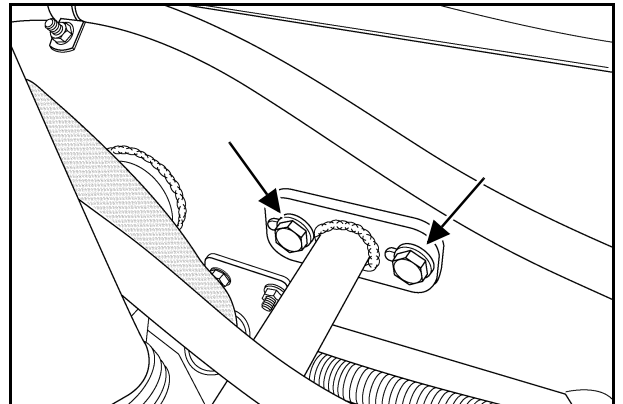

MD05N100

Mark the position of the bracket on the frame.

Remove the two LH front hood support bracket mounting bolts, washers and nuts.

STEP 26

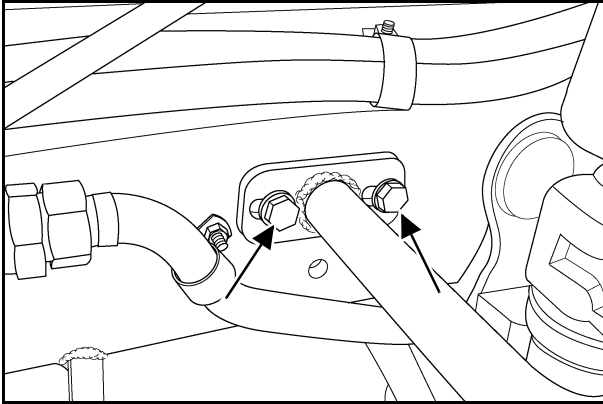

MD05N101

Mark the position of the bracket on the frame.

Remove the two LH rear support bracket mounting bolts and washers.

STEP 27

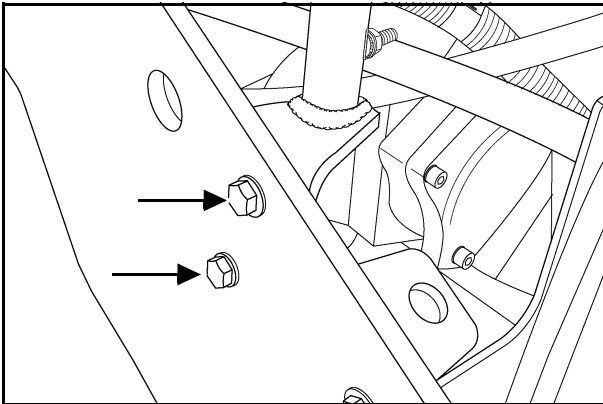

MD05N099

Mark the position of the bracket on the frame.

Remove the two RH support bracket mounting bolts, washers and nuts.

Remove the hood support assembly from the tractor.

STEP 28

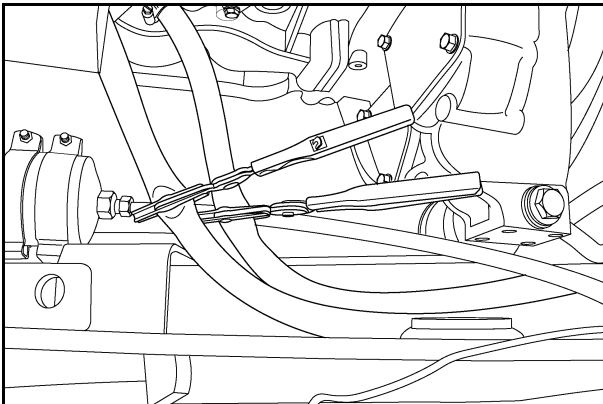

MD05N106

Install clamps on the heater hoses.

STEP 29

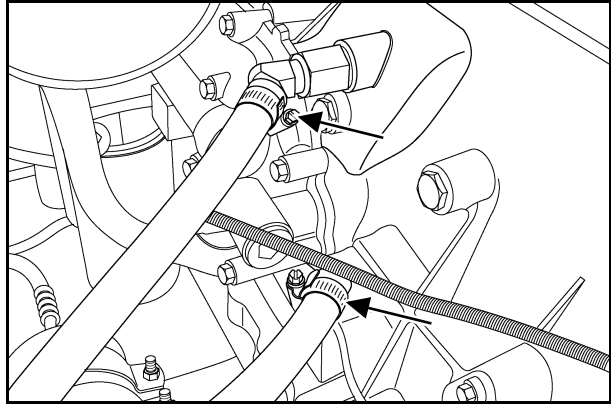

MD05N107

Remove the heater hoses from the engine.

STEP 30

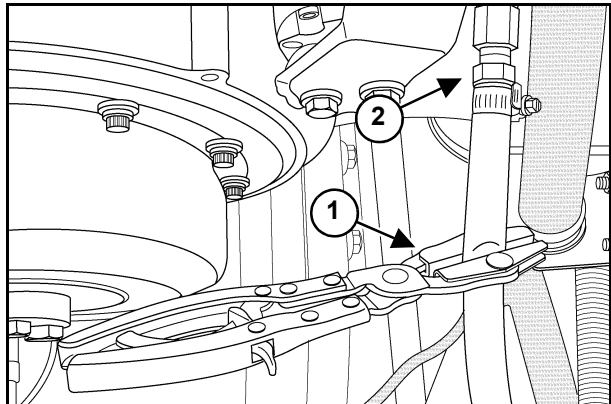

MD05N108

Install a clamp (1) on the fuel return hose and remove the hose from the engine (2).

STEP 31

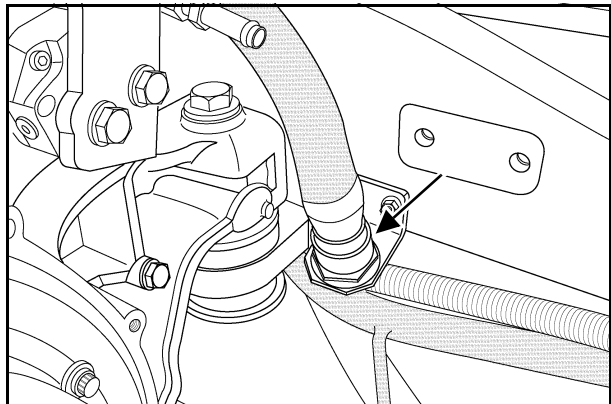

MD05N109

Remove the engine wire harness connector from the front frame harness.

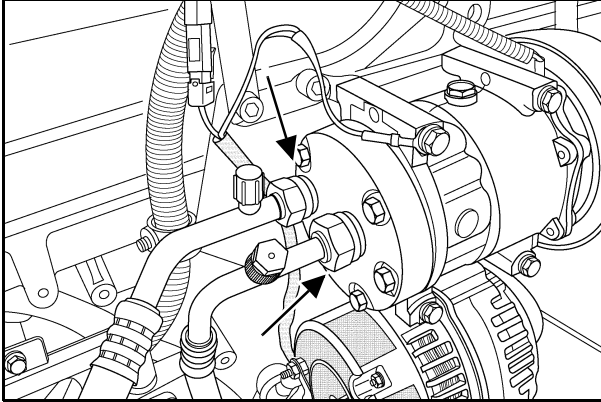
STEP 32

MD05N110

Remove the two A/C hoses from the compressor. Install plugs in the hose ends and caps on the compressor ports.

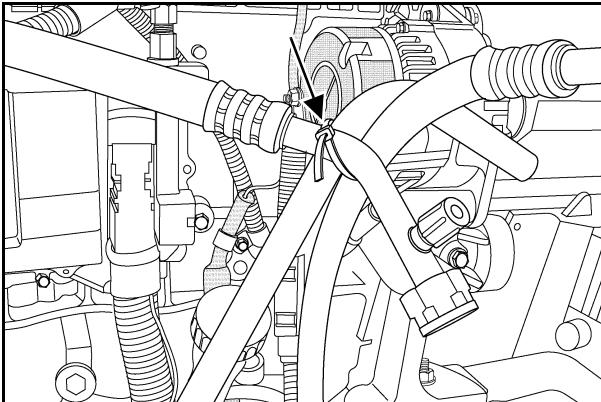
STEP 33

MD05N111

Carefully move the A/C hoses away from the engine and secure the hoses to the RH trash screen brace.

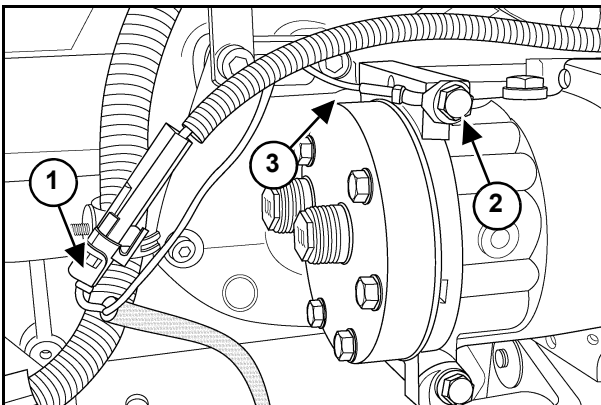
STEP 34

MD05N112

Remove the A/C clutch wire connector (1) from the engine wire harness. Remove the top rear compressor mounting bolt (2) and remove the ground wire (3) from the bolt (2). Install the bolt (2).

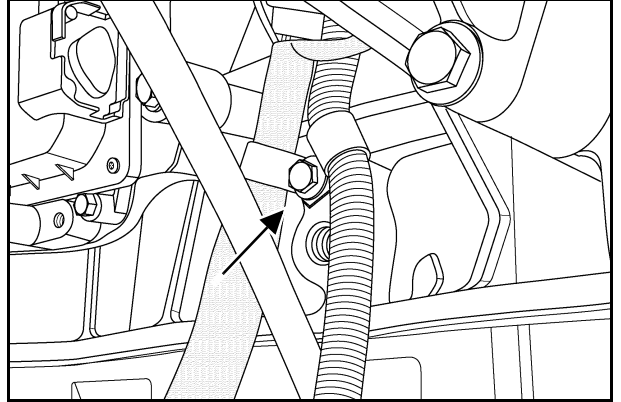
STEP 35

MD05N114

Remove the alternator wire P-clamp from the engine.

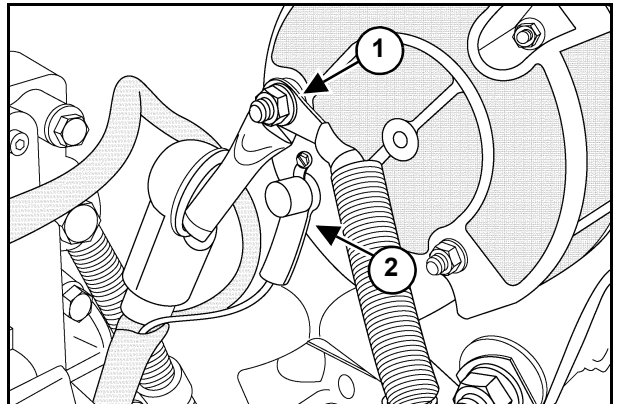
STEP 36

MD05N113

Remove the battery cable (1) and exciter wire (2) from the alternator.

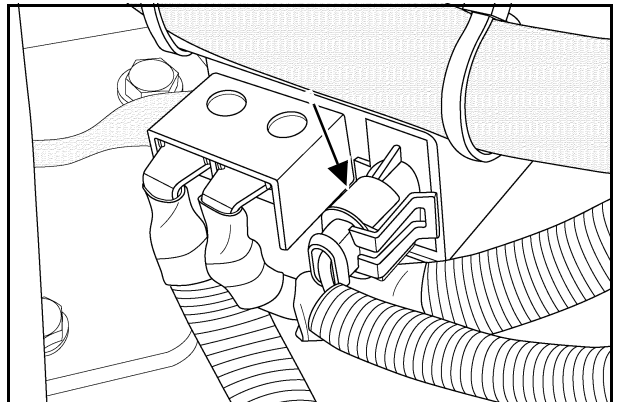
STEP 37

MD05N115

Remove the heater grid solenoid coil wire connector from the solenoid.

STEP 38

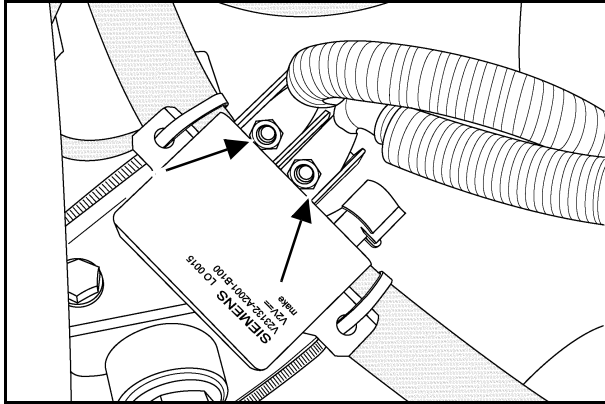

MD05N116

Label and remove the cables from the grid heater solenoid.

STEP 41

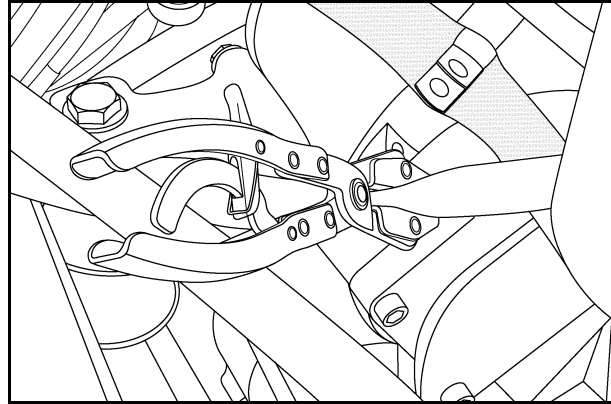

MD05N119

Install a clamp on the fuel supply hose.

STEP 39

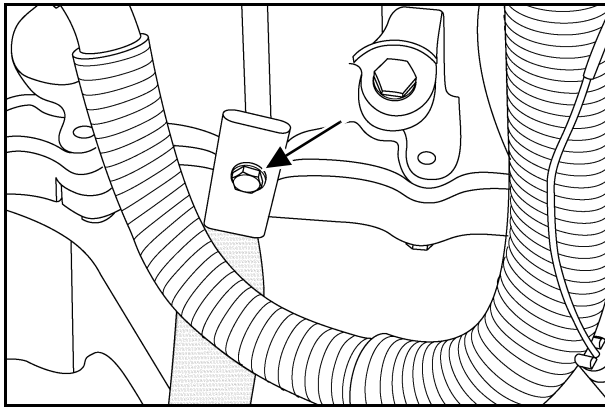

MD05N117

Remove the ground strap from the engine.

STEP 42

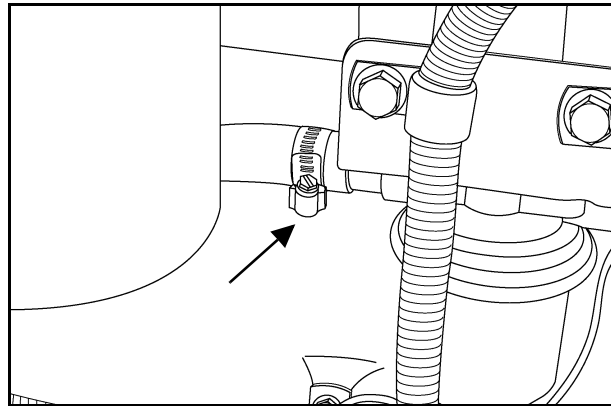

MD05N162

Remove the fuel supply hose from the engine.

STEP 40

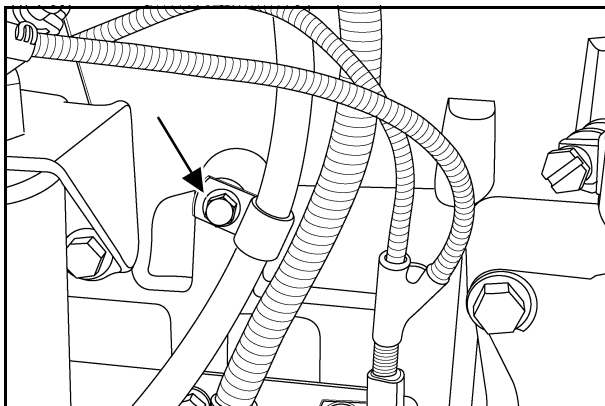

MD05N118

Remove the fuel hose P-clamp from the engine.

STEP 43

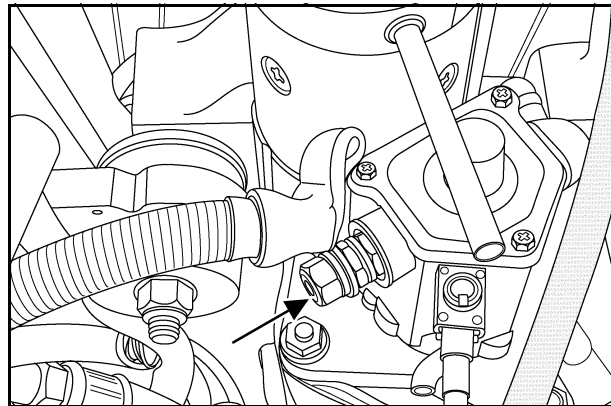

MD05N163

Remove the wires from the starter.



Suggest:

If the above button click is invalid.

Please download this document

first, and then click the above link

to download the complete manual.

Thank you so much for reading

STEP 44

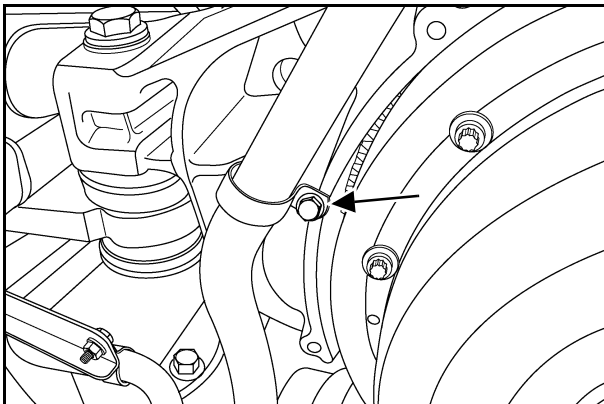

MD05N167

Remove the engine breather tube P-clamp from the engine.

STEP 47

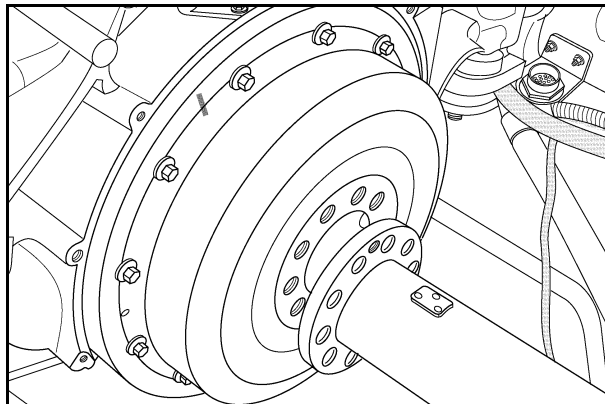

MD05N172

Move the driveshaft away from the engine drive coupler.

STEP 45

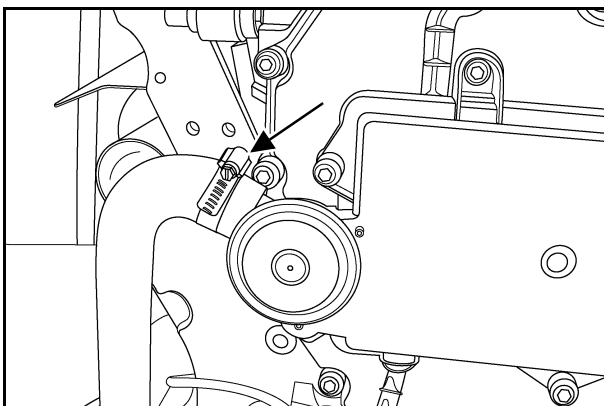

MD05N166

Remove the engine breather tube from the breather filter.

STEP 48

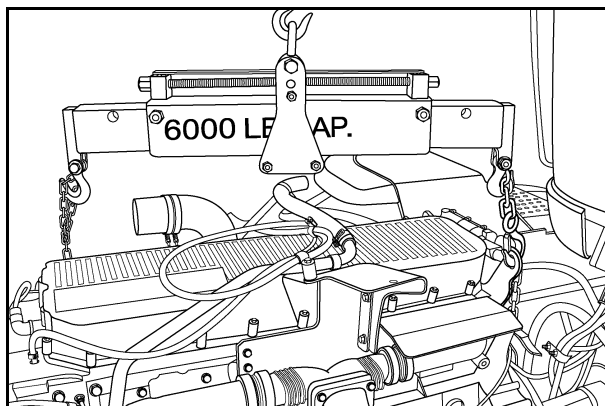

MD05N173

Install an OEM 4130 Load Rotor on the two engine lifting brackets. Attach the load rotor to an overhead hoist.

STEP 46

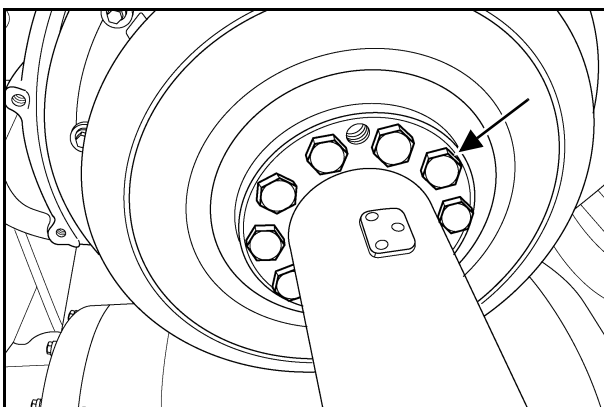

MD05N171

Remove the ten drive shaft mounting bolts.

IMPORTANT: *The engine lifting brackets are for vertical lifting only. Any lifting device that is not in-line vertically with the lifting brackets can damage the engine rocker arm cover or cause bracket failure.*

<https://www.ebooklibonline.com>

Hello dear friend!

Thank you very much for reading.

Enter the link into your browser.

The full manual is available for immediate download.

<https://www.ebooklibonline.com>