



MX Magnum - Service Manual Complete Table of Contents

Description	Book Number	Section Number	Publication Number
Standard Torque Specifications	1	1000	6-14200
Safety, General Information/Maintenance Schedule	1	1001	6-14200
General Specifications and Special Torques	1	1002	6-14200
Engine Removal and Installation	1	2002	6-14200
Fuel Tank Removal and Installation	1	3001	6-14200
Electrical System (Prior to P.I.N. JAZ129933) How it Works and Troubleshooting	2	4001	6-14210
Electrical System (P.I.N. JAZ129933 and After) How it Works and Troubleshooting	2A	4001	6-12741
Steering Column and Steering Hand Pump	3	5001	6-14221
Powershift Transmission System How it Works and Troubleshooting	3	6000	6-14221
Transmission Input Shaft and Drive Plate	3	6001	6-14221
Input Drop Box	3	6002	6-14221
Engine Frame and Input Drop Box Split	3	6003	6-14221
Speed to Range Transmission Split	3	6005	6-14221
Speed Transmission	3	6006	6-14221
Range Transmission to Rear Frame Split	3	6007	6-14221
Range Transmission	3	6008	6-14221
Transmission Control Valves and Inching Valve	3	6009	6-14221
Rear Frame	4	6011	6-14231
Hydraulic Pump Drive	4	6012	6-14231
Mechanical Front Drive MFD Control System How it Works	4	6013	6-14231
Differential Lock Control System How it Works	4	6014	6-14231
MFD Clutch And Output Shaft Removal Without Tractor Split	4	6015	6-14231
MFD Drive Shaft	4	6016	6-14231
Limited Slip MFD Differential	4	6017	6-14231

Description	Book Number	Section Number	Publication Number
Locking MFD Differential	4	6018	6-14231
Rear Axle and Planetaries	4	6019	6-14231
Power Take Off Control System How it Works	4	6020	6-14231
MFD Planetary Hub, Steering Knuckle, and Axle Drive Shaft	4	6022	6-14231
Suspension MFD Axle	4	6023	6-14231
Suspended MFD Axle System How It Works and Troubleshooting	4	6024	6-14231
Brake Valve	4	7001	6-14231
Brake Cylinders	4	7002	6-14231
Park Brake	4	7004	6-14231
Trailer Brake System - How It Works	4	7005	6-14231
PTO Assembly - Single and Dual Speeds	4A	6021	7-86731
PTO Clutch Assembly Single and Reversible Single Speeds	4A	6025	6-17540
How to Read Symbols in a Hydraulic Schematic	5	8000	6-14241
Hydraulic System How it Works with Troubleshooting	5	8001	6-14241
PTO and Differential Lock Valve	5	8002	6-14241
Remote Valve and Coupler Service	5	8003	6-14241
Remote Hydraulic System How it Works and Troubleshooting	5	8004	6-14241
Priority and Regulator Valve	5	8005	6-14241
Charge Pump	5	8006	6-14241
PFC Piston Pump and Hydraulic Filter	5	8007	6-14241
Hitch System - How it Works	5	8008	6-14241
Hitch Control Valve	5	8009	6-14241
Pedal & Pedal Switch Adjustments	5	9001	6-14241
Cab Raise/Removal and Installation	5	9005	6-14241
Tilt And Fixed Hoods, A/C Condenser, Radiator, And Air-To-Air Aftercooler	5	9008	6-14241



Description	Book Number	Section Number	Publication Number
Air Conditioning Troubleshooting	5	9010	6-14241
Air Conditioner System Service	5	9020	6-14241
Viscous Fan Drive Test	5	9030	6-14241
Standard Instrumentation Programming and Fault Codes	6	10001	6-14250
Hitch Controller Calibration and Fault Codes	6	10002	6-14250
Transmission Controller (With Suspended Axle) Calibration and Fault Codes	6	10003	6-14250
Armrest Controller Calibration and Fault Codes	7	10004	6-14260
Remote Hydraulics Controller Calibration and Fault Codes	7	10005	6-14260
PTO Controller Configuration and Fault Codes	7	10006	6-14260
Performance Monitor Controller Fault Codes	7	10008	6-14260
Instrument Cluster (ICU2) Programming and Fault Codes	8	10009	6-17550



<https://www.ebooklibonline.com>

Hello dear friend!

Thank you very much for reading.

Enter the link into your browser.

The full manual is available for immediate download.

<https://www.ebooklibonline.com>

Service Information Packaged with 6-12722

Electrical Schematic (Prior to P.I.N. JAZ129933) 6-12750
Electrical Schematic (P.I.N. JAZ129933 and After) 6-17260
Hydraulic Schematic 6-12830
Loctite Product Chart 8-98902
A/C Temperature Poster 6-13060

Service Information Not Packaged with 6-12723 But Required for Engine Repair

Electronic 8.3L Engine for MX255 and MX285 Manual Numbers 7-88622 and 7-88631
Mechanical 8.3L Engine for MX210 and MX230 Manual Number 7-65440



Section 1001

SAFETY, GENERAL INFORMATION / MAINTENANCE SCHEDULE

SAFETY



THIS SAFETY ALERT SYMBOL INDICATES IMPORTANT SAFETY MESSAGES IN THIS MANUAL. WHEN YOU SEE THIS SYMBOL, CAREFULLY READ THE MESSAGE THAT FOLLOWS AND BE ALERT TO THE POSSIBILITY OF PERSONAL INJURY OR DEATH.

M171B

To prevent injury always follow the Warning, Caution and Danger notes in this section and throughout the manual.

Put the warning tag shown below on the key for the key switch when servicing or repairing the machine. One warning tag is supplied with each machine. Additional tags are available from your service parts supplier.

Before servicing a machine, park the machine on hard level ground. Turn off the engine, apply the parking brake and remove the key from the key switch. Put blocks in front of and behind either the front or rear wheels.



WARNING: *Before starting engine study Operators Manual safety messages. Read all safety signs on machine. Clear the area of other persons. Learn and practice safe use of controls before operating. It is your responsibility to understand and follow manufacturers instructions on machine operation, service, and to observe pertinent laws and regulations. Operator and Service Manuals may be obtained from your equipment dealer.*

M103A

DO NOT OPERATE

Reason _____

Signed by _____

DO NOT REMOVE THIS TAG!

See Other Side

Case Part No _____ Printed in U.S.A.

201L95



WARNING: *If you wear clothing that is too loose or do not use the correct safety equipment for your job, you can be injured. Always wear clothing that will not catch on objects. Extra safety equipment that can be required includes hard hat, safety shoes, ear protection, eye or face protection, heavy gloves and reflector clothing.*

M492



WARNING: *When working in the area of the fan belt with the engine running, avoid loose clothing if possible, and use extreme caution.*

M493



WARNING: *Read the operators manual to familiarize yourself with the correct control functions.*

M489



WARNING: *When doing checks and tests on the equipment hydraulics, follow the procedures as they are written. DO NOT change the procedure.*

M494



WARNING: *Operate the machine and equipment controls from the seat position only. Any other method could result in serious injury.*

M490



WARNING: *When putting the hydraulic cylinders on this machine through the necessary cycles to check operation or to remove air from a circuit, make sure all people are out of the way.*

M495



WARNING: *This is one man machine, no riders allowed.*

M491



WARNING: Always wear heat protective gloves to prevent burning your hands when handling heated parts.

SM121A



WARNING: Lower all attachments to the ground or use stands to safely support the attachments before you do any maintenance or service.

M496



WARNING: Hydraulic oil or diesel fuel leaking under pressure can penetrate the skin and cause infection or other injury.

To Prevent Personal Injury:

Relieve all pressure, before disconnecting fluid lines. Before applying pressure, make sure all connections are tight and components are in good condition.

Never use your hand to check for suspected leaks under pressure.

Use a piece of cardboard or wood for this purpose. If injured by leaking fluid, see your doctor immediately.

SM171A



WARNING: When removing hardened pins such as a pivot pin, or a hardened shaft, use a soft head (brass or bronze) hammer or use a driver made from brass or bronze and a steel head hammer.

M497



WARNING: When using a hammer to remove and install pivot pins or separate parts using compressed air or using a grinder, wear eye protection that completely encloses the eyes (approved goggles or other approved eye protectors).

M498



WARNING: Use suitable floor (service) jacks or chain hoist to raise wheels or tracks off the floor. Always block machine in placed with suitable safety stands.

M499



WARNING: When servicing or repairing the machine. Keep the shop floor and operators compartment and steps free of oil, water, grease, tools, etc. Use an oil absorbing material and or shop cloths as required. Use safe practices at all times.

M500



WARNING: Some components of this machine are very heavy. Use suitable lifting equipment or additional help as instructed in the Service Manual.

M501



WARNING: Engine exhaust fumes can cause death. If it is necessary to start the engine in a closed place, remove the exhaust fumes from the area with an exhaust pipe extension. Open the door and get outside air into the area.

M502



WARNING: When the battery electrolyte is frozen, the battery can explode if (1), you try to charge the battery, or (2), you try to jump start and run the engine. To prevent the battery electrolyte from freezing, try to keep the battery at full charge. If you do not follow these instructions, you or others in the area can be injured.

M503



WARNING: Batteries contain acid and explosive gas. Explosions can result from sparks, flames or wrong cable connections. To connect the jumper cables correctly to the battery of this machine see the Operators Manual. Failure to follow these instructions can cause serious injury or death.

M504

GENERAL INFORMATION

Cleaning

Clean all metal parts except bearings, in mineral spirits or by steam cleaning. Do not use caustic soda for steam cleaning. After cleaning, dry and put oil on all parts. Clean oil passages with compressed air.

Inspection

Check all parts when the parts are disassembled. Replace all parts that have excessive wear or are damaged. Small scoring or grooves can be removed with a hone or crocus cloth. Complete visual inspection for indications of wear, pitting and the replacement of parts necessary will prevent early failures.

Bearings

Clean bearings with a good clean solvent and permit to air dry. **DO NOT DRY BEARINGS WITH COMPRESSED AIR.** Check bearings for smooth easy action. If the bearing has a loose fit or rough action, the bearing must be replaced.

Needle Bearings

Before you press needle bearings into a bore, always remove any metal protrusions in the bore or the edge of the bore. Before you press bearings into position, put petroleum jelly on the inside and outside diameter of the bearing.

Gears

Check all gears for excessive wear or damage. Replace gears as necessary.

Oil Seals, O-rings and Gaskets

Always install new oil seals, O-rings and gaskets. Put petroleum jelly on seals and O-rings.

Shafts

Check all shafts for excessive wear or damage. Check the bearing and oil seal surfaces on the shafts for excessive wear or damage. Replace shafts as necessary.

Service Parts

Always install genuine Case service parts. When ordering refer to the Parts Catalog for the correct part number of the genuine Case replacement items. Failures due to the use of other than genuine Case replacement parts are not covered by warranty.

Lubrication

Use only the oils and lubrication specified in the Operators or Service Manual. Failures due to the use of non specified oils and lubricants are not covered by warranty.

MAINTENANCE SCHEDULE

Service Interval	Maintenance Requirement	Check	Grease	Change	Clean
When Warning Message Displays	Air Cleaner Element				X
Every 10 Hours Or Daily	Engine Oil Level	X			
	Engine Coolant Level	X			
	Transmission Oil Level	X			
Every 50 Hours	Engine Primary Fuel Filter - Drain Water				
Every 100 Hours	Front Hitch (If Equipped)		X		
Every 300 Hours	Battery Water Level	X			
	Engine Air Intake Hoses	X			
	Engine Coolant Level-Deaeration Tank	X			
	*Engine Oil And Filter			X	
	Front And Rear Wheel Bolt Torques	X			
	Front Axle And Rear Hitch (Note A)		X		
	Fuel Tank - Drain Water				
	Differential And Planetary Oil Level (Note B)	X			
Every 600 Hours	Engine Coolant Antifreeze Protection	X			
	Engine Coolant Filter			X	
	Engine Coolant Hoses And Clamps	X			
	Engine Fuel Filters			X	
	Changeable PTO Internal Splines		X		
Every 1200 Hours Or Annually	Engine Primary And Secondary Air Filter			X	
	Engine Air Precleaner				X
	Differential and Planetary Oil			X	
Every 1200 Hours	Engine Valve Adjustment (Model 210 & 230) (Note C)	X			
Every 1500 Hours	Transmission Oil, Filter(s) and Breather			X	
Every 2400 Hours	Engine Coolant And Coolant Conditioner			X	
	Engine Fuel Injection Nozzles and Pump See (Note C)	X			
	Engine Crankshaft Dampener (Note C)	X			
As Required	Cab Air And Recirculation Filters			X	X
	Cab Air Filter Dust Valve	X			
	Engine Primary Air Filter				X
	Grill Screens, Radiator, Condenser/Fuel Cooler, Oil Cooler, Air to Air Cooler				X
	Serpentine Belt			X	
	Tire Pressure	X			

Note A -In severe or wet conditions, Interval is every 10 hours or daily.

Note B - Perform initial service in first 50 hours of operation.

Section 2002

ENGINE REMOVAL AND INSTALLATION

ENGINE REMOVAL

STEP 1



96R-28A

Park the tractor on a hard, level surface. Put the transmission shift lever in PARK. Turn off the engine and remove the key. Place blocks in front of and behind the rear wheels. Drain the radiator coolant into a suitable, clean container.



WARNING: Check and service cooling system according to maintenance instructions. Hot coolant can spray out if the deaeration tank cap is removed while system is hot. To remove the deaeration tank cap, let system cool, turn to the first notch, then wait until all the pressure is released. Scalding can result from the fast removal of the deaeration tank cap.

M855

STEP 2



RD02E069

Remove the toolbox and battery cover. Disconnect the negative (-) battery cable. Disconnect the positive (+) battery cable.

STEP 3

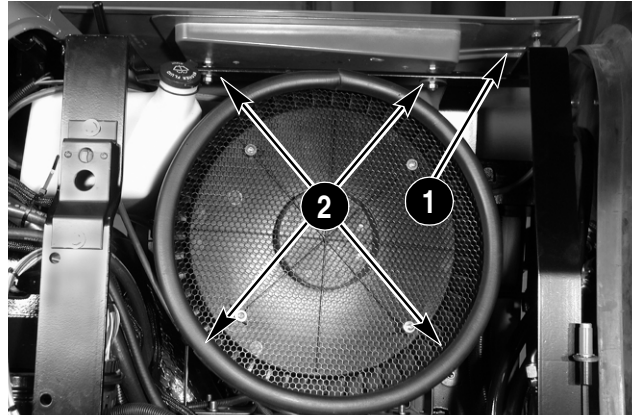

RD02E060

Lift up and remove the air cleaner door from the left side of the tractor. Remove the front windshield washer hose (1) from the nozzle on the fixed hood. Remove the four nuts (2) and lift the fixed hood from the right side of the tractor.

STEP 4

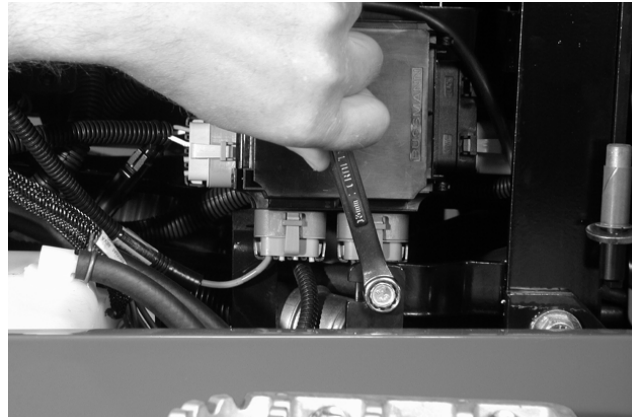

RD02F129

Remove the left lower fixed hood panel.

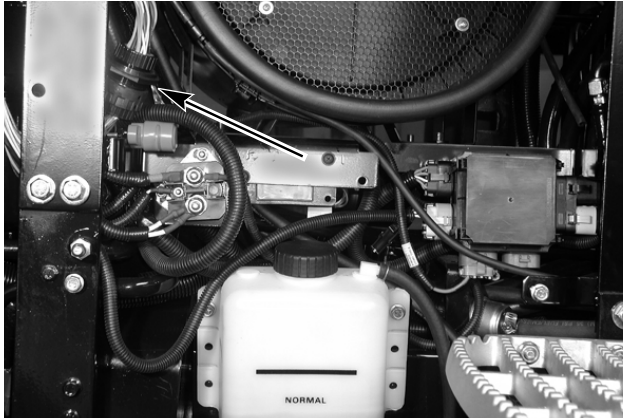
STEP 5

RD02F134

Disconnect the main wiring harness connector.

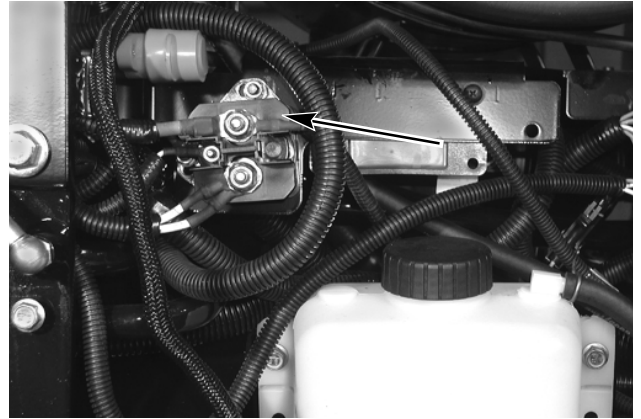
STEP 8

RD02F131

Remove the starter solenoid from the hood support.

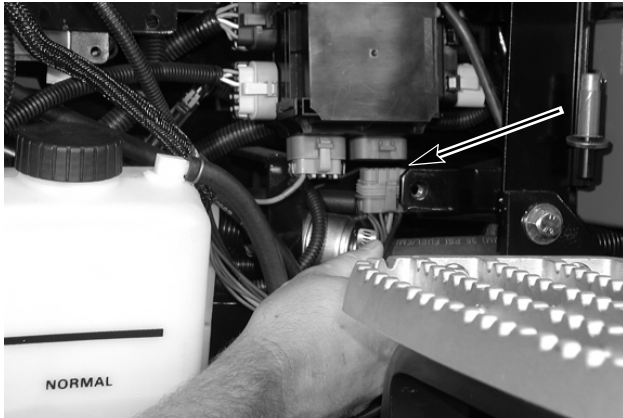
STEP 6

RD02F130

Tag and disconnect the electrical plugs from the fuse box. Remove the electrical plug for the tilt hood front lamps. Remove the tilt hood. Refer to Section 9008 in this service manual for the procedure.

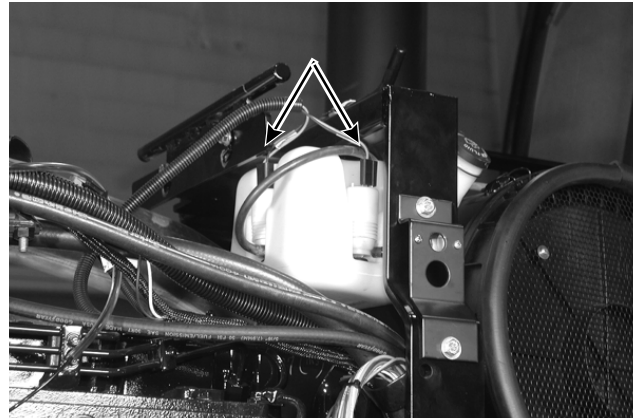
STEP 9

RD02F133

Remove the windshield washer reservoir electrical connectors.

STEP 7

RD02F132

Remove the passive terminator harness.

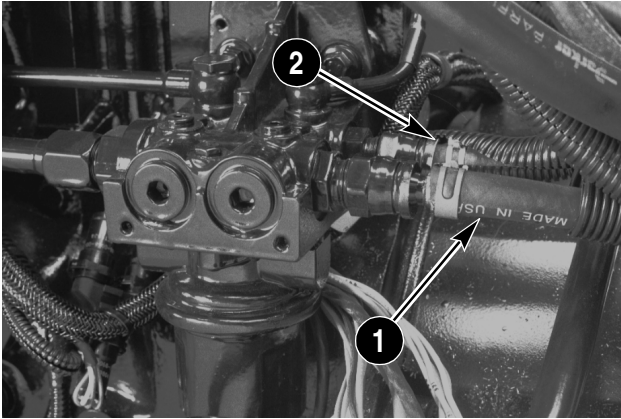
STEP 10

2-14

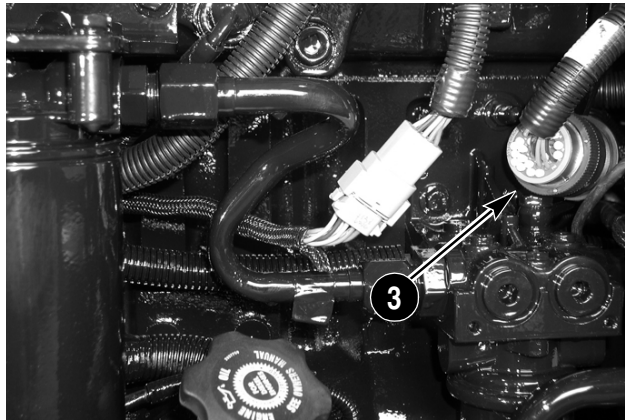

RD02F146

On electronic injection pump models, remove the fuel supply line (1) and the return line (2). Disconnect the electronic injection pump wiring harness connector (3).

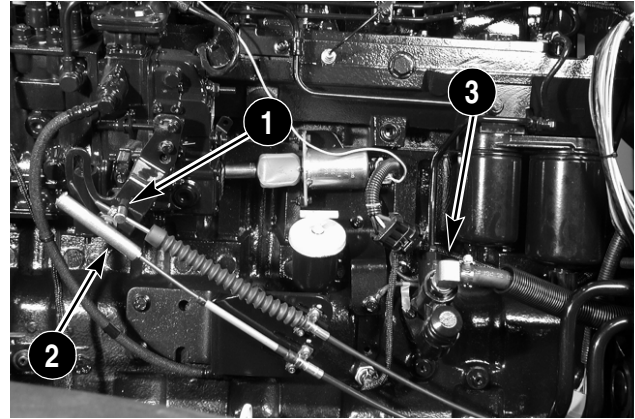
STEP 11

RD02F141

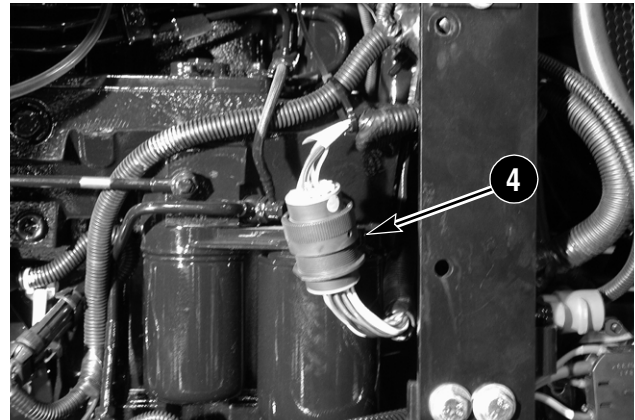

RD02F175

On mechanical injection pump models, remove the optional foot throttle cable (1), if equipped, the hand throttle cable (2), the fuel supply line (3), and the engine wiring harness connector (4).

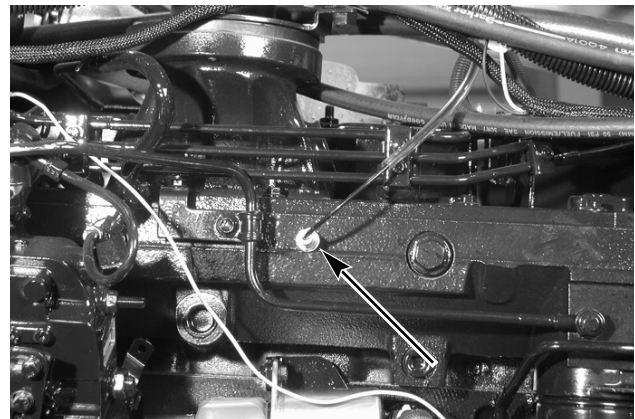
STEP 12

RD02F150

Disconnect the ether start tube from the intake manifold on the left side of the engine.

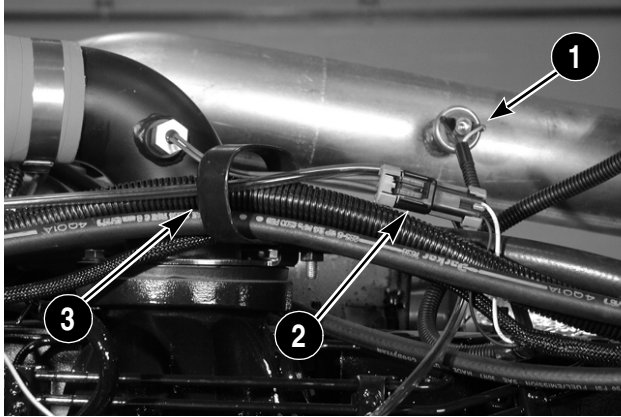
STEP 13

RD02F143

Disconnect the electrical connectors from the air filter sensor (1) on the air cleaner outlet tube. Disconnect the electrical plug (2) for the intake manifold temperature sensor. Remove the three harness and hose retainers (3) on the left side of the engine.

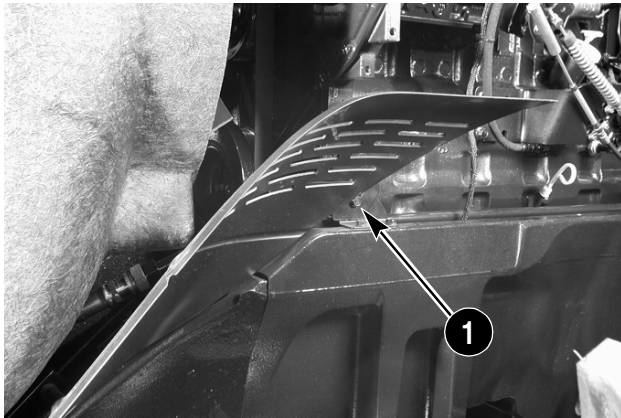
STEP 14

RD02F152

Remove the left and right fan shields by removing the bolt (1) and pulling out on the shield.

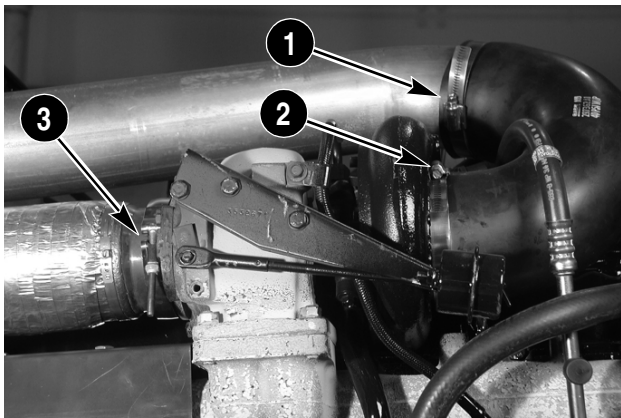
STEP 15

RD02F137

Remove the air cleaner outlet tube at the turbocharger elbow clamp (1). Loosen and remove the turbocharger elbow at the turbo clamp (2). Loosen the clamp (3) at the turbo outlet pipe.

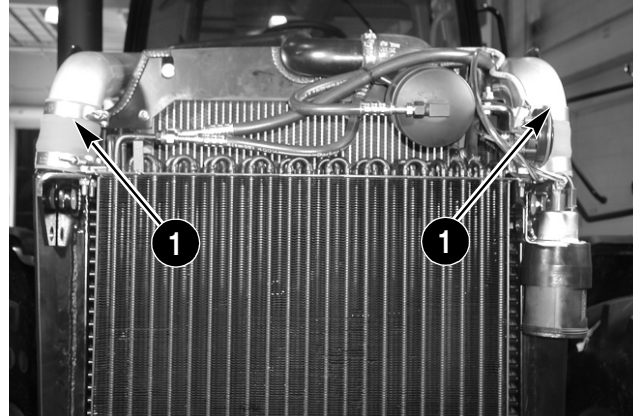
STEP 16

RD02F144

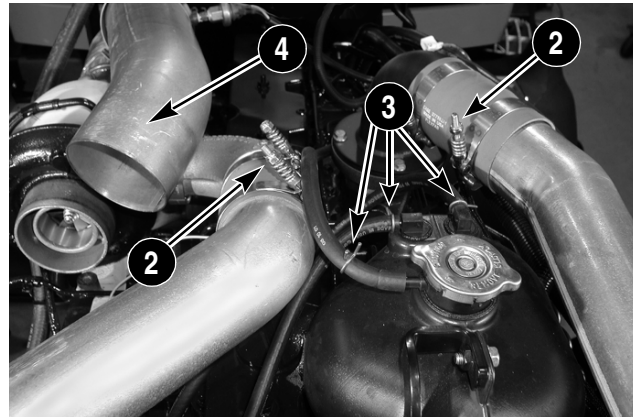

RD02F157

Remove the upper hose clamps (1) at the air-to-air aftercooler. Remove the hose clamps (2) from the aftercooler tubes to the intake manifold and the turbo. Remove the aftercooler tubes. Tag and remove the three hoses (3) from the deaeration tank. Remove the air cleaner outlet tube (4) at the air cleaner rubber elbow clamp.

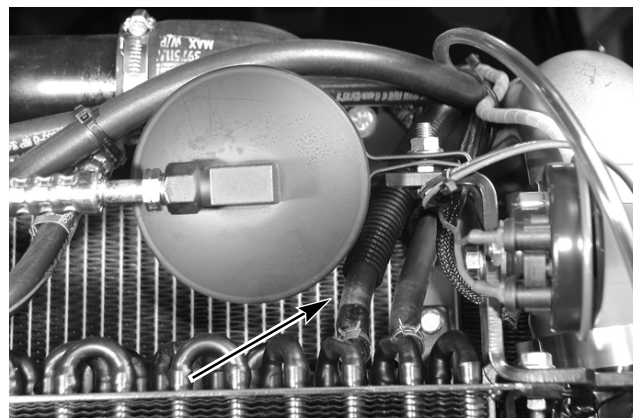
STEP 17

RD02F151

Trace the line back to the injection pump, so the correct line is removed. Disconnect the fuel return line from the fuel injection pump at the fuel cooler.

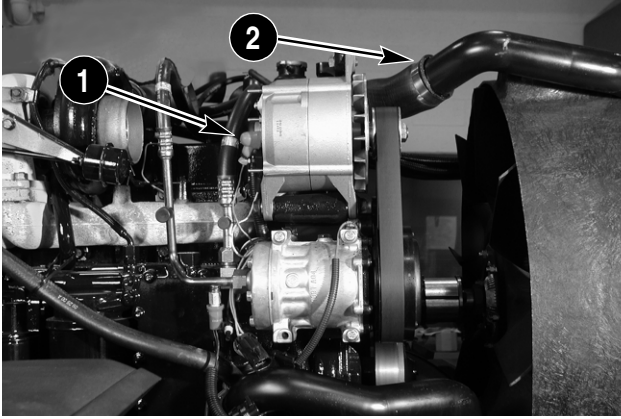
STEP 18

RD02F153

Tag and remove the two wires (1) from the back of the alternator and the battery cable. Remove the upper radiator hose at the clamp (2).

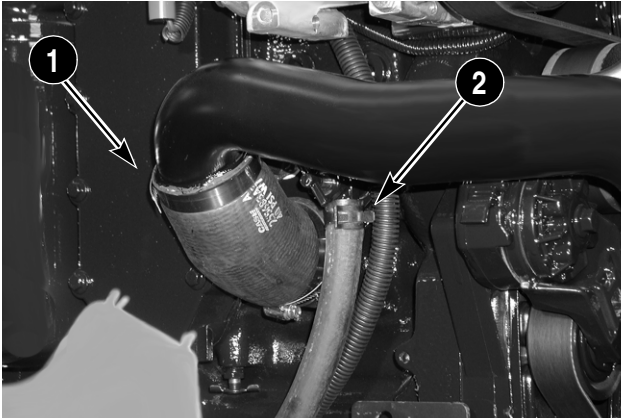
STEP 19

RD02F171

Remove the lower radiator hose at the hose clamp (1). Remove the heater return hose at the hose clamp (2).

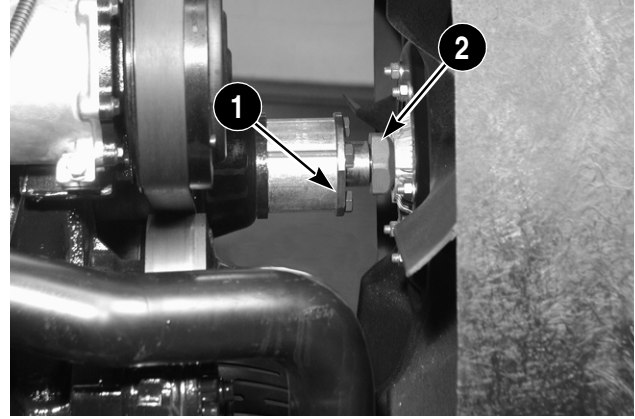
STEP 20

RD02F173

Hold the shaft (1) of the fan hub on the two flat areas. Remove the fan blade and fan drive by loosening the viscous fan drive adapter (2).

IMPORTANT: *The viscous fan drive adapter has a left-hand thread. Loosen by turning clockwise.*

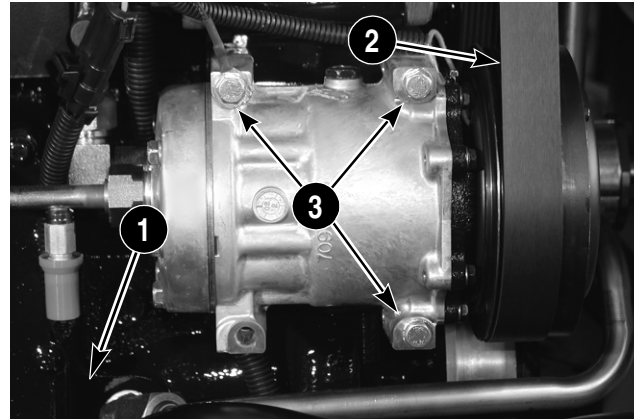
STEP 21

RD02F170

Disconnect the two electrical connectors from the air conditioning compressor high pressure switch (1) and the clutch. Remove the engine fan belt (2). Remove the three air conditioning compressor mounting bolts (3).

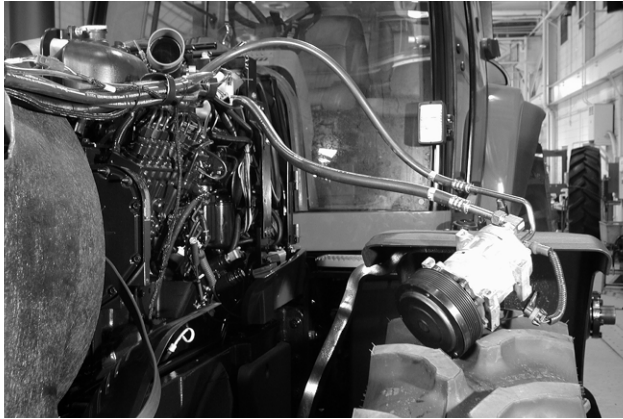
STEP 22

RD02F156

Move the air conditioning compressor to the left side of the tractor, with the hoses attached. Securely support the compressor.

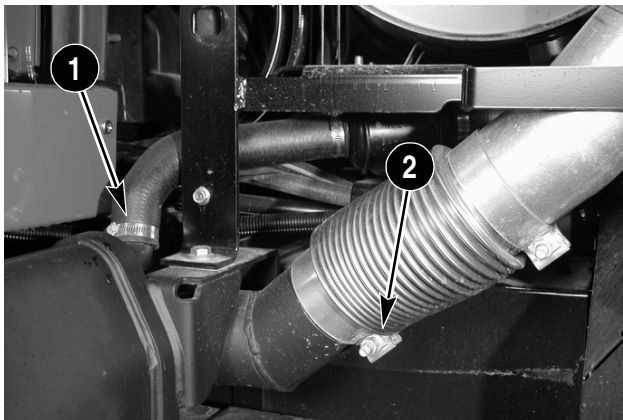
STEP 23

RD02F139

Remove the aspirator tube hose (1) at the exhaust elbow. Loosen the lower clamp (2) on the exhaust flex pipe.

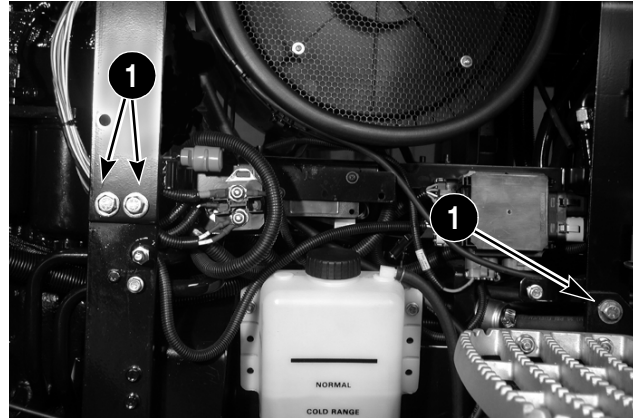
STEP 24

RD02F138

Remove the fixed hood support bolts (1) from both sides of the tractor. Properly support the air cleaner assembly and the hood support and remove from the tractor. Remove the turbo outlet pipe.

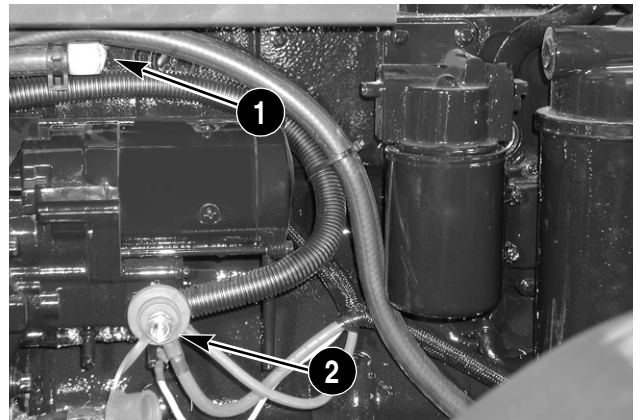
STEP 25

RD02F172

Remove the heater supply hose (1) from the fitting on the engine block. Remove the cables from the starter terminal (2). Remove the harness and hose retainer attached to the flywheel shield behind the engine block. Move the harnesses and hoses out of the way.

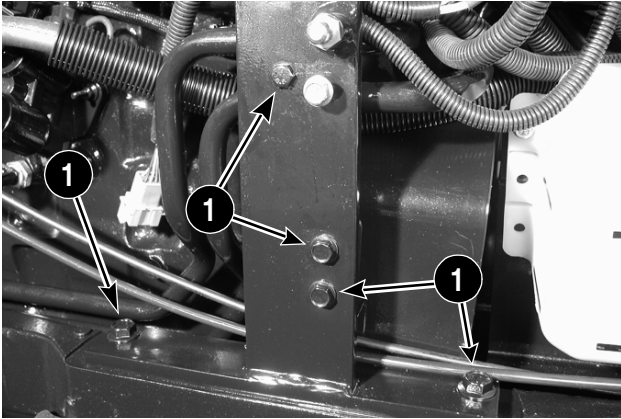
STEP 26

RD02F140

Remove the five bolts (1) for the left-hand hood support bracket. Remove the four bolts for the right-hand hood support bracket, along with the engine to frame ground strap. Remove the brackets.

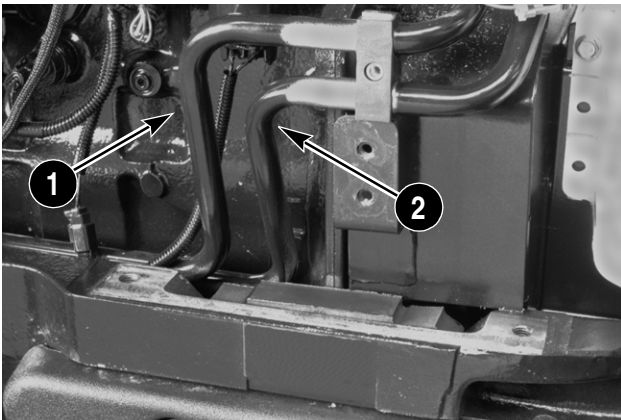
STEP 27

2-2

Remove the oil cooler supply tube (1) and the oil cooler return tube (2).

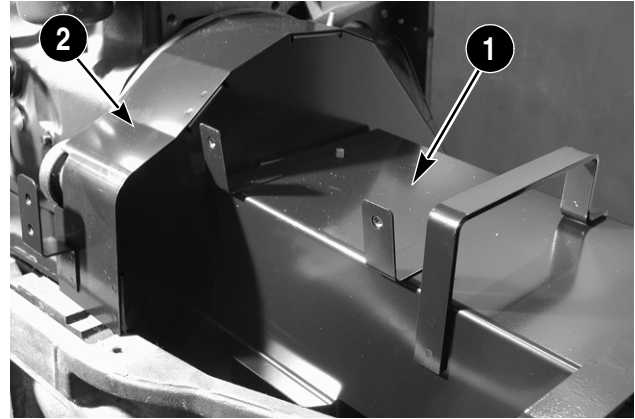
STEP 28

RD02F174

Remove the drive shaft shield (1) and the flywheel shield (2). Refer to Section 6001, Transmission Input Shaft and Drive Plate, for the procedure.

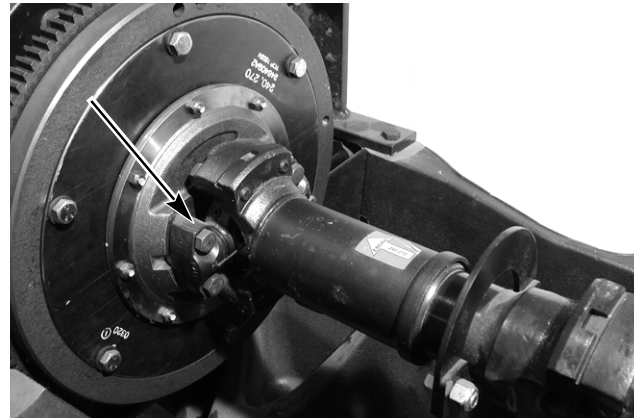
STEP 29

RD02F176

Make an alignment mark on the end of the drive shaft connected to the engine for installation. Remove the four bolts attaching the front universal joint to the drive plate. Slide the drive shaft back.

STEP 30

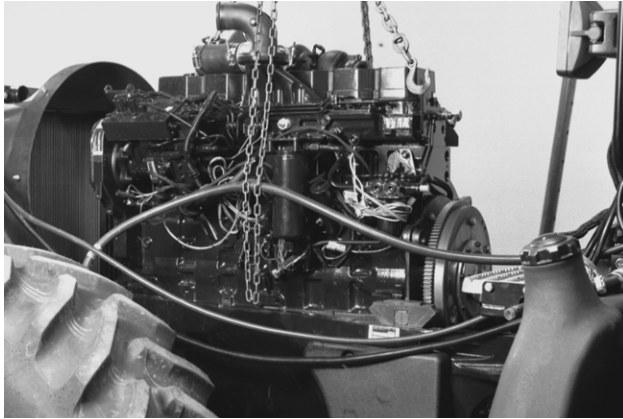

4-12

Attach suitable lifting equipment to the front and rear engine lifting brackets. Put a small amount of tension on the hoist.

STEP 31

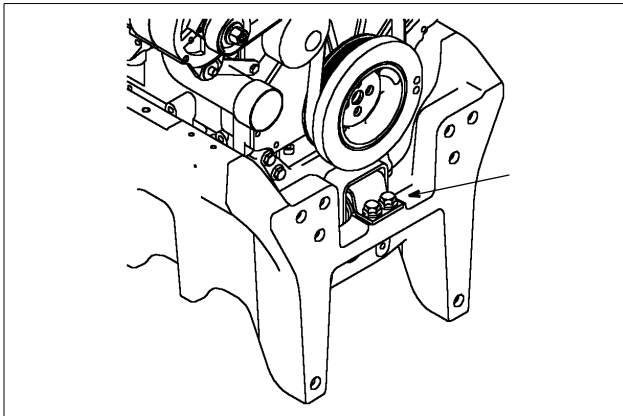

RI01H053

Remove the two front engine mount clamp bolts. Remove the clamp.

STEP 32

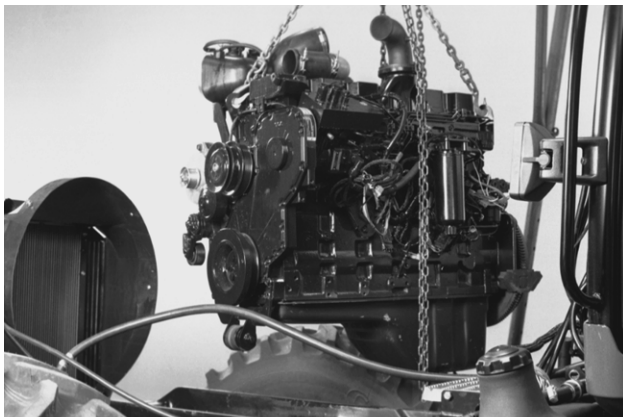

4-14

Remove the engine.

NOTE: Make sure all electrical wires and hoses are disconnected before removing the engine.

STEP 33

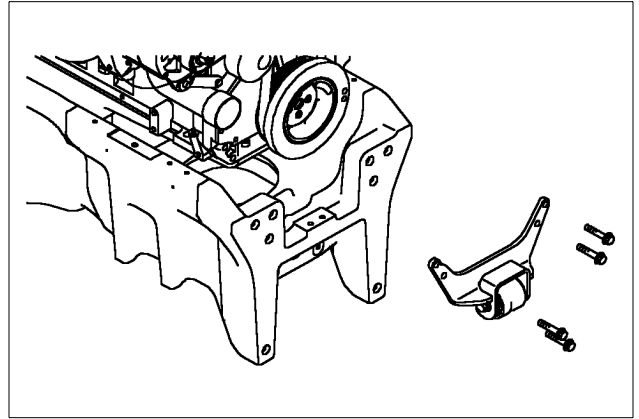

RI01H055

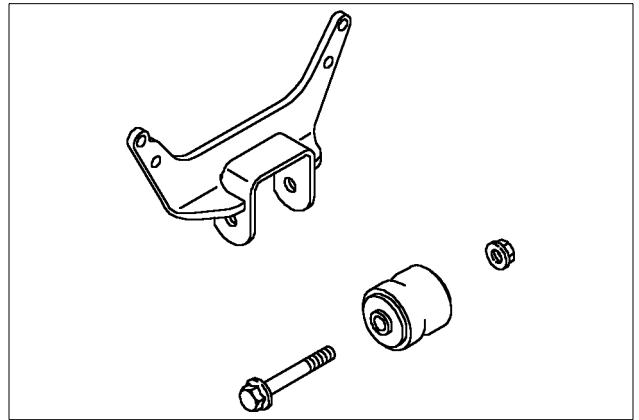

RI01H052

Inspect the front engine mount support and the iso-mount for damage or wear. Replace, if necessary.

STEP 34

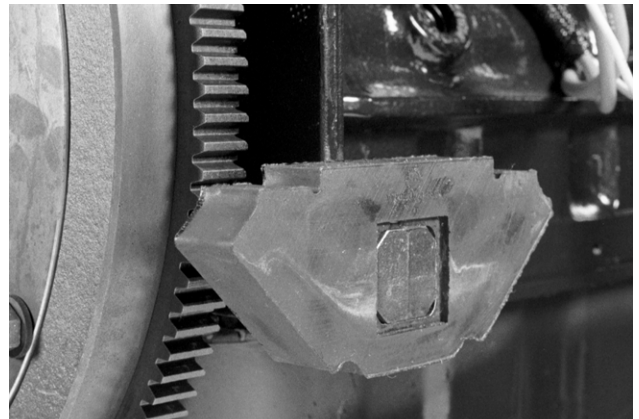

4-23CR1

Inspect the two engine rear rubber mounts for damage or wear. Replace, if necessary.

ENGINE INSTALLATION

STEP 35

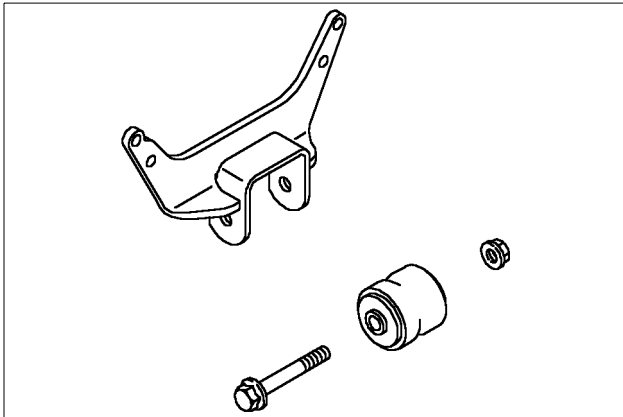

RI01H052

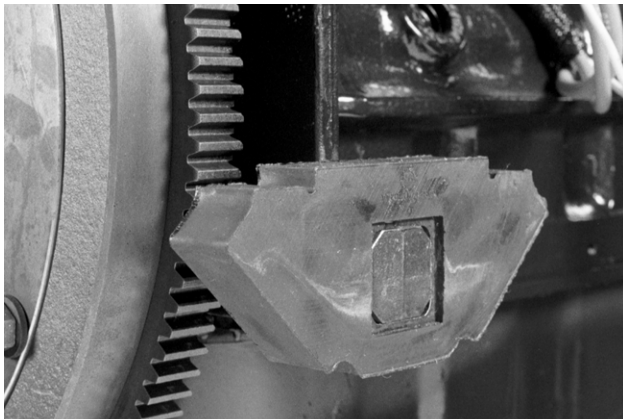

4-23CR1

If removed, assemble the front engine iso-mount and install the rear engine rubber mounts. Tighten the front iso-mount thru bolt to a torque of 160 to 220 Nm (118 to 162 lb ft).

STEP 36

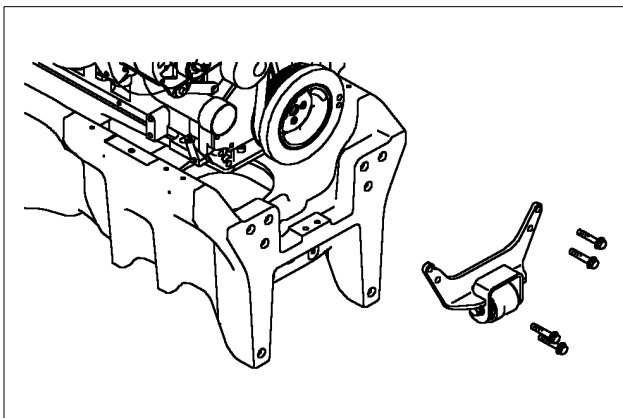

RI01H055

If removed, install the front engine mount support and the iso-mount. Tighten the front engine mount support bolts to a torque of 101 to 113 Nm (75 to 83 lb ft).

STEP 37

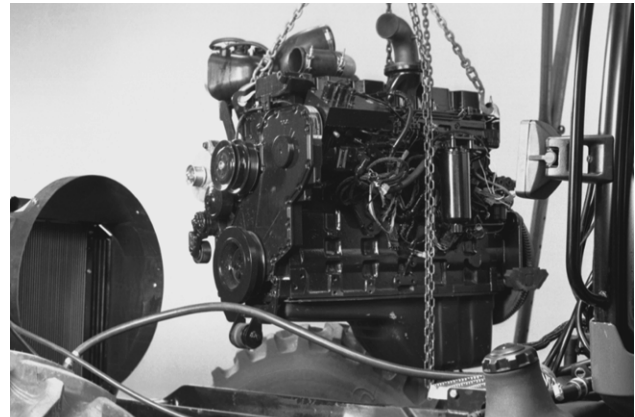

4-14

Properly support the engine. Install the engine into the tractor chassis.

NOTE: Make sure all electrical wires and hoses will not be pinched or binding when installing the engine.

STEP 38

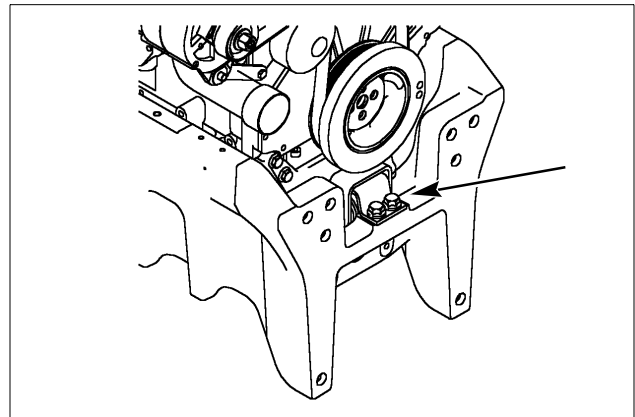

RI01H053

Install the two front engine mount clamp bolts. Keep tension on the lifting equipment until these bolts are installed. Relieve the tension on the lifting equipment. Tighten the bolts to a torque of 59 to 106 Nm (44 to 78 lb ft).

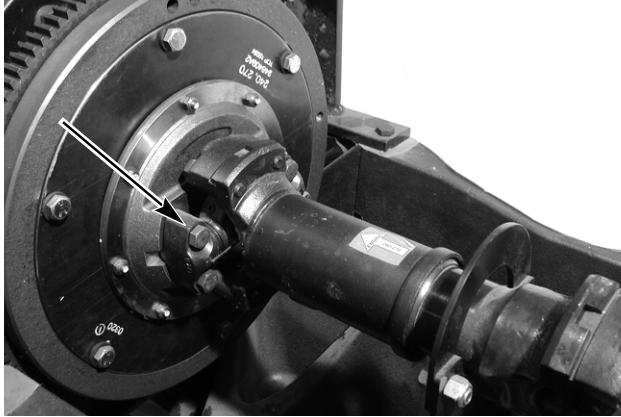
STEP 39

RD02F176

Using the alignment mark made during the removal, pull the drive shaft forward and install the drive shaft to the drive plate. Tighten the drive shaft yoke bolts to a torque of 58 to 64 Nm (43 to 47 lb ft) for the MX210 and the MX230, 101 to 113 Nm (75 to 83 lb ft) for the MX255 and the MX285. Tighten the bolts in a crossing pattern.

NOTE: Use a rubber mallet to lightly tap the outside edge of the top bearing end cap to position it into the keyway of the yoke. Do not use the bolts to pull the bearing end caps into the yoke keyway.

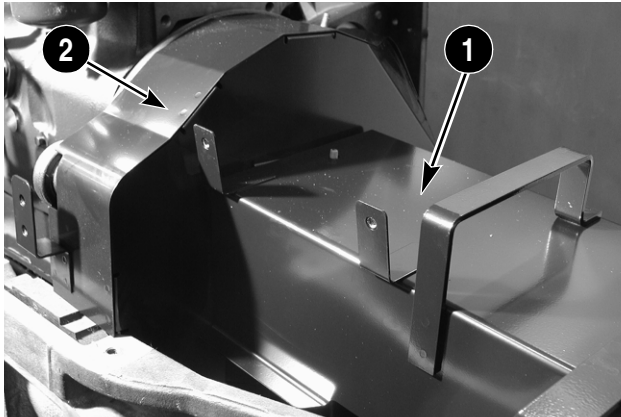
STEP 40

RD02F174

Install the drive shaft shield (1) and flywheel shield (2). Refer to Section 6001 in this manual, Transmission Input Shaft and Drive Plate, for the procedure.

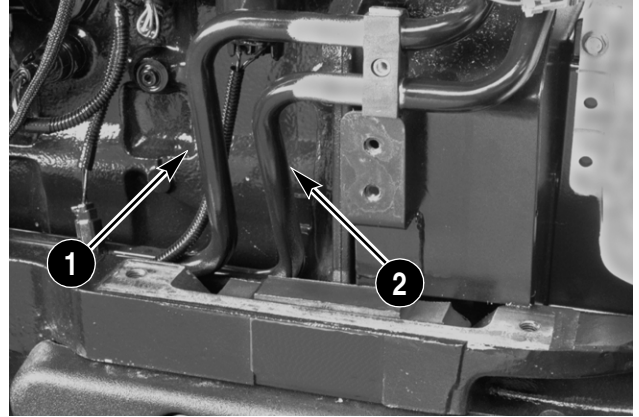
STEP 41

2-2

Install the oil cooler supply tube (1) and the oil cooler return tube (2).

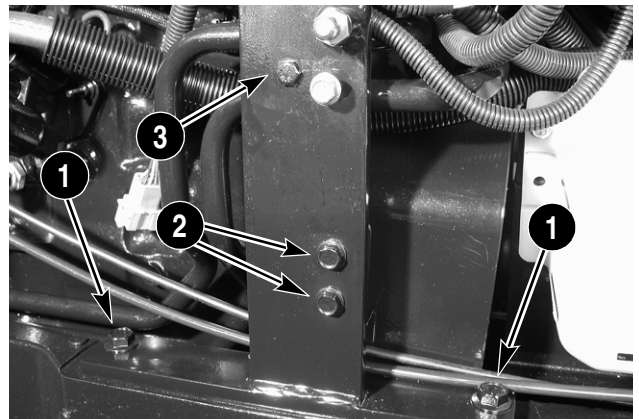
STEP 42

RD02F140

Install the two bolts (1) for the left-hand hood support bracket. Install the two bolts (2) for the flywheel shield. Install the bolt (3) for the oil cooler tube clamp. Install the four bolts for the right-hand hood support bracket, along with the engine to frame ground strap.

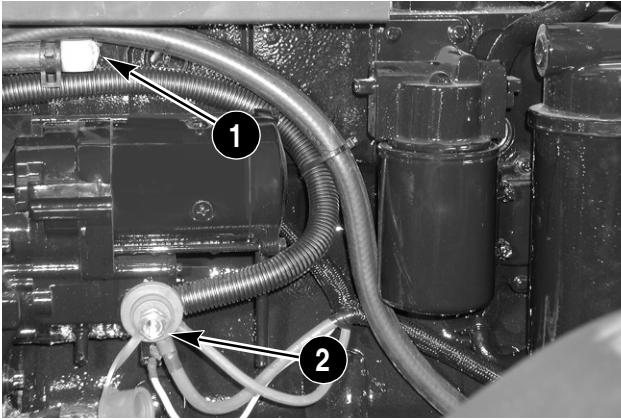
STEP 43

RD02F172

Install the heater supply hose (1) on the engine block fitting. Install the cables on the starter terminal (2). Install the harness and hose retainer attached to the flywheel shield, behind the engine block. Route the harnesses and hoses as shown.

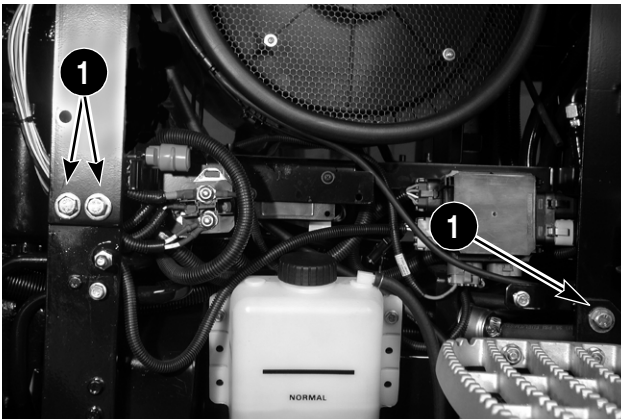
STEP 44

RD02F138

Install the turbo outlet pipe. Slightly tighten the clamp at the turbo. Properly support the air cleaner assembly and the hood support and lower into position. Install the fixed hood support bolts (1) on both sides of the tractor.

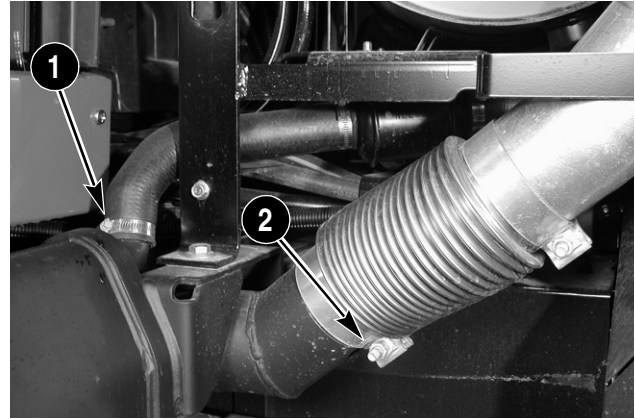
STEP 45

RD02F139

Install the aspirator tube hose clamp (1) at the exhaust elbow. Tighten the exhaust flex pipe lower clamp (2).

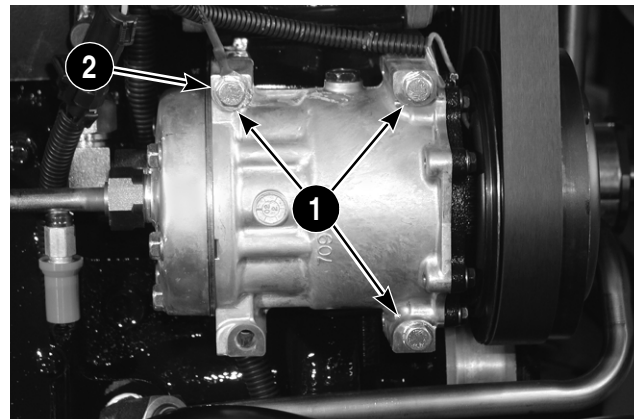
STEP 46

RD02F170

Position the compressor and hoses on the engine. Install the three air conditioning compressor mounting bolts (1) along with the ground wire terminal (2). Install the engine fan belt. Connect the two electrical connectors leading to the air conditioning compressor high pressure switch and the clutch.

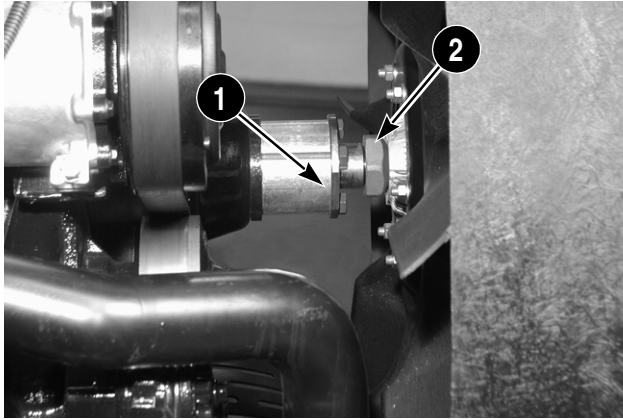
STEP 47

RD02F173

Hold the shaft (1) of the fan hub on the two flat areas. Install the fan blade and fan drive by tightening the viscous fan drive adapter (2).

IMPORTANT: *The viscous fan drive adapter has a left-hand thread. Tighten by turning counterclockwise. Do not over tighten the viscous fan drive adapter on installation.*

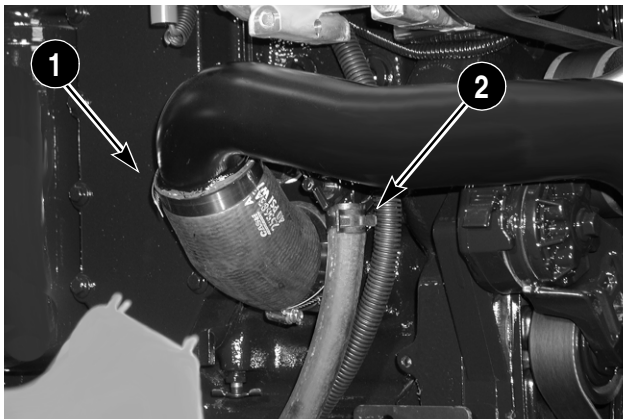
STEP 48

RD02F171

Install the lower radiator hose at the hose clamp (1). Install the heater return hose at the hose clamp (2).

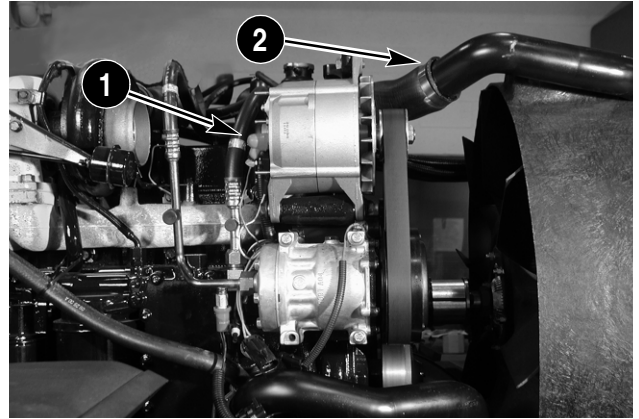
STEP 49

RD02F153

Install the two wires on the back of the alternator (1), and the battery cable. Install the upper radiator hose at the hose clamp (2).

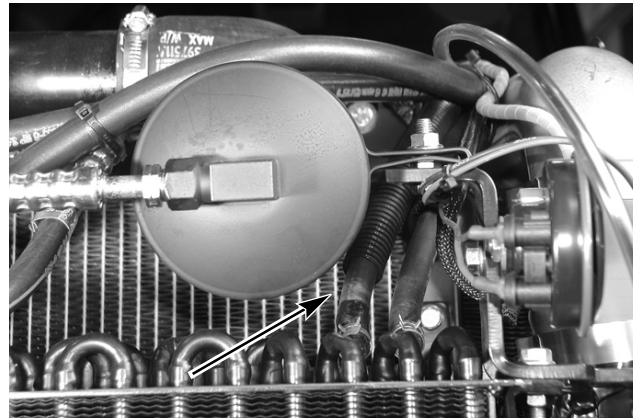
STEP 50

RD02F151

Connect the fuel return line from the fuel injection pump to the fuel cooler.

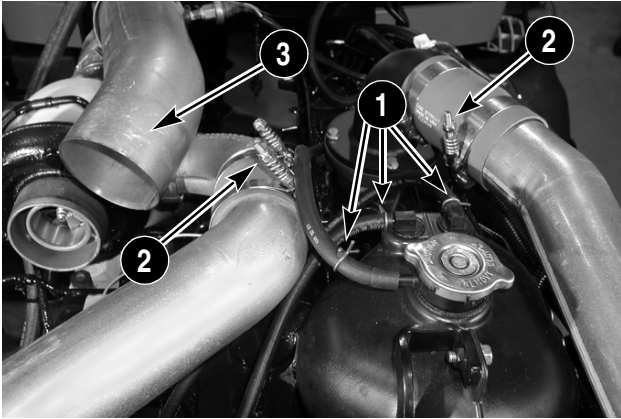
STEP 51

RD02F157

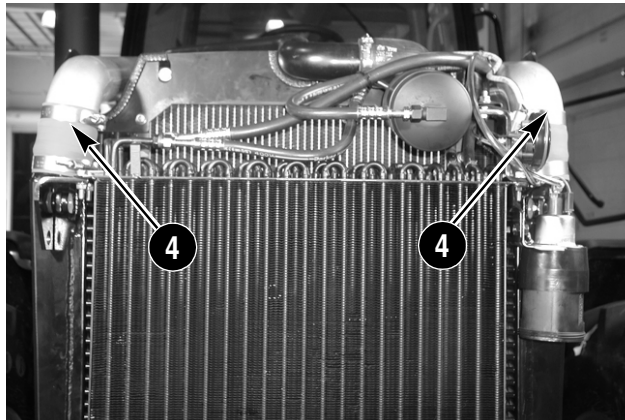

RD02F144

Install the three hoses (1) at the deaeration tank. Install the aftercooler tubes at the intake manifold and the turbo at the hose clamps (2). Install the air cleaner outlet tube (3) at the air cleaner clamp. Install the aftercooler tube upper hose clamps (4) at the air-to-air aftercooler.

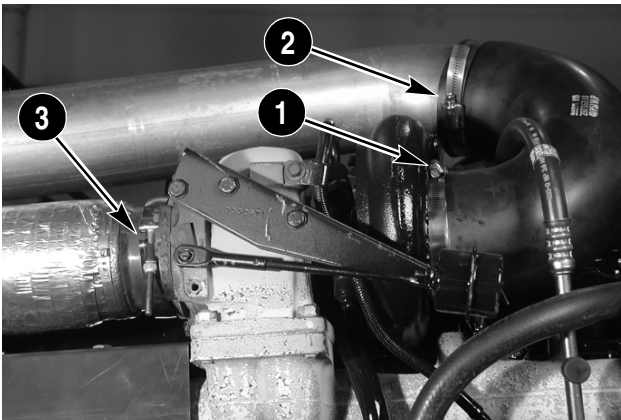
STEP 52

RD02F137

Install the turbocharger elbow at the turbo clamp (1). Install the air cleaner outlet tube at the turbocharger elbow clamp (2). Tighten the clamp (3) at the turbo outlet pipe.

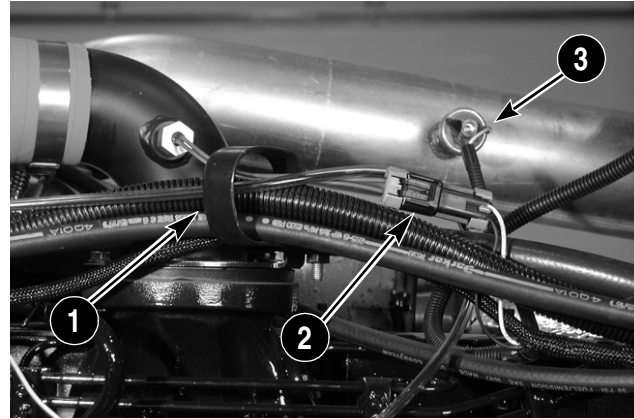
STEP 53

RD02F143

Install the three harness and hose retainers (1) on the left side of the engine. Install the electrical plug for the intake manifold temperature sensor (2). Install the electrical connectors at the air filter sensor (3) on the air cleaner outlet tube.

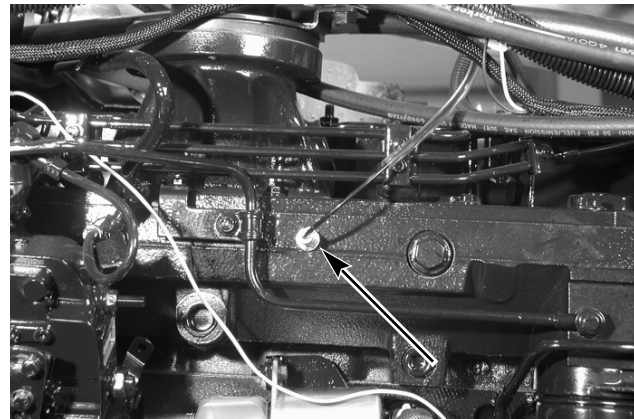
STEP 54

RD02F150

Connect the ether start tube to the intake manifold on the left side of the engine.

STEP 55

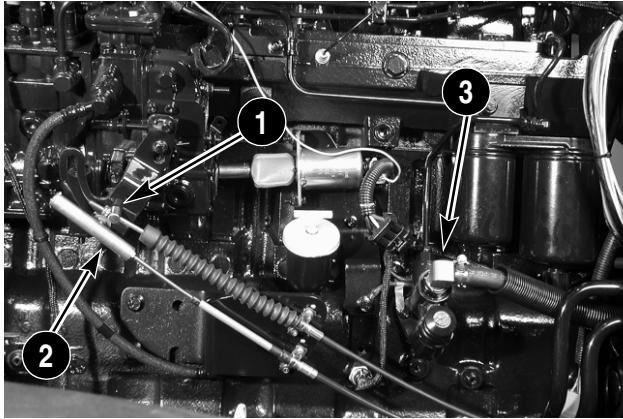

RD02F141

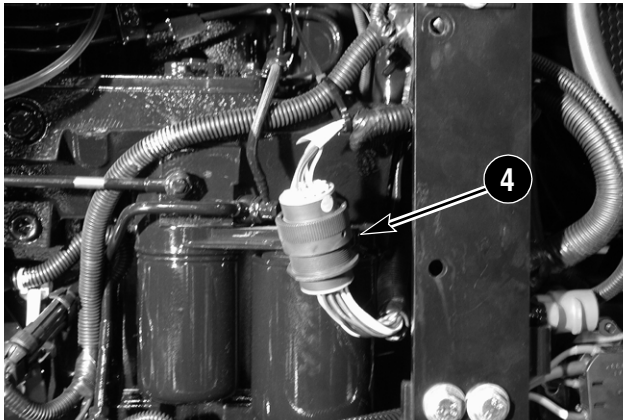

RD02F175

On mechanical injection pump models, install the optional foot throttle cable (1), if equipped, the hand throttle cable (2), the fuel supply line (3), and the engine wiring harness connector (4).

STEP 56

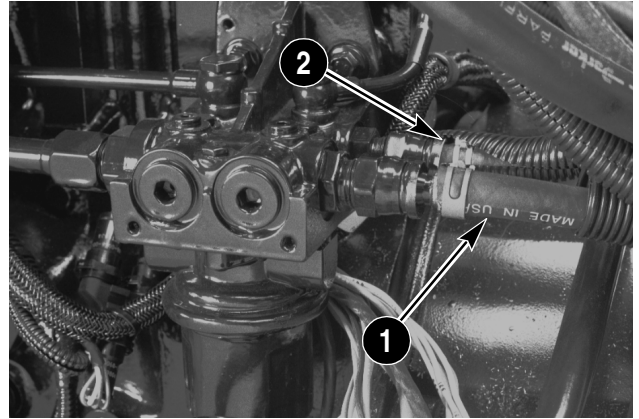

2-14

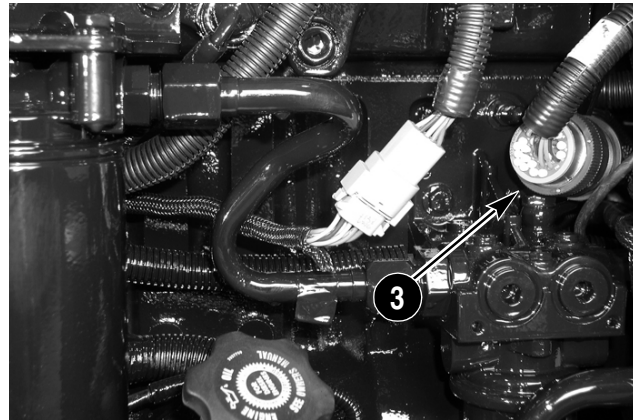

RD02F146

On electronic injection pump models, install the fuel supply line (1) and the return line (2). Connect the electronic injection pump wiring harness at the connector (3).

STEP 57

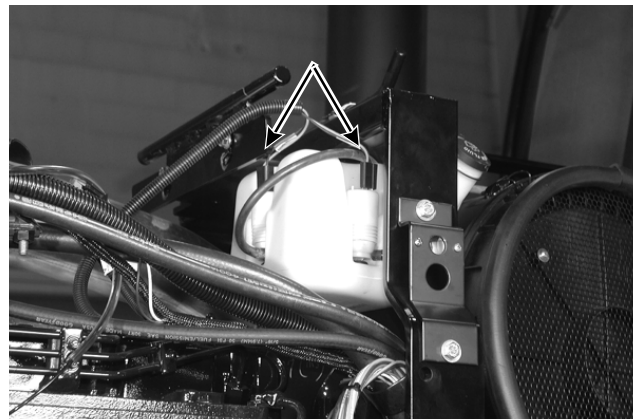

RD02F133

Install the windshield washer reservoir electrical connectors.

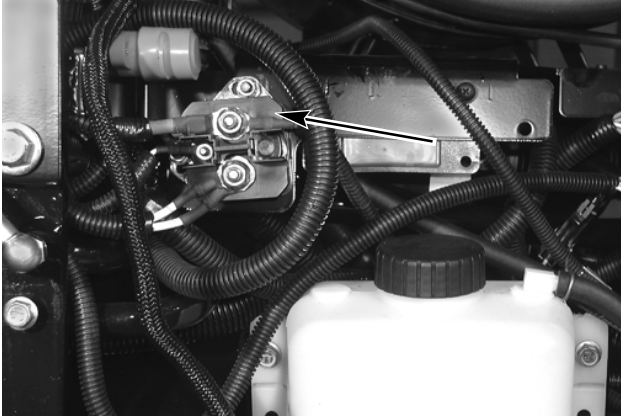
STEP 58

RD02F131

Install the starter solenoid on the hood support.

STEP 59

RD02F132

Connect the passive terminator harness.

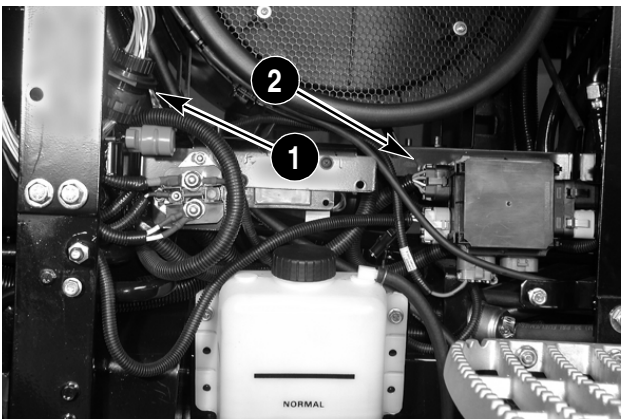
STEP 60

RD02F134

Connect the main wiring harness connector (1). Connect the remaining electrical plugs at the fuse box (2).

STEP 61

Close the petcock on the hose located under the tractor radiator. Check and replace all filters, as required. Fill the cooling system. Check the coolant level at the coolant reservoir and the deaeration tank. Check all fluid levels before starting the engine. Make sure the transmission shift lever is in PARK. Start the engine briefly. Shut the engine off and recheck all connections and fluid levels. Restart and run the engine. Turn the engine off and remove the key.

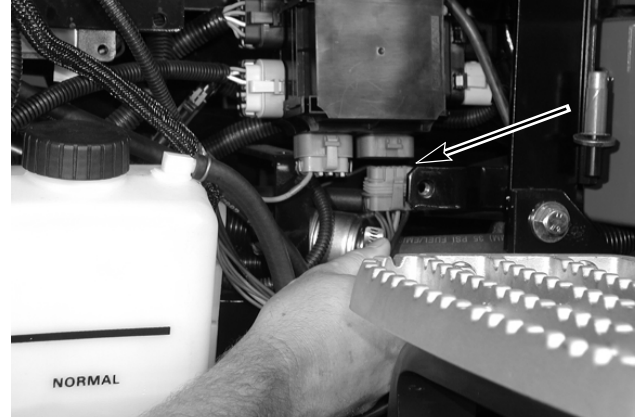
STEP 62

RD02F130

Install the tilt hood. Refer to Section 9008 for the procedure. Connect the electrical plug for the tilt hood front lamps.

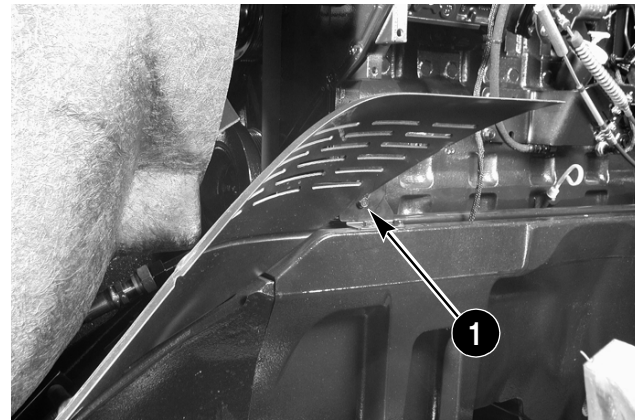
STEP 63

RD02F152

Install the left and right fan shields and tighten the bolt (1).

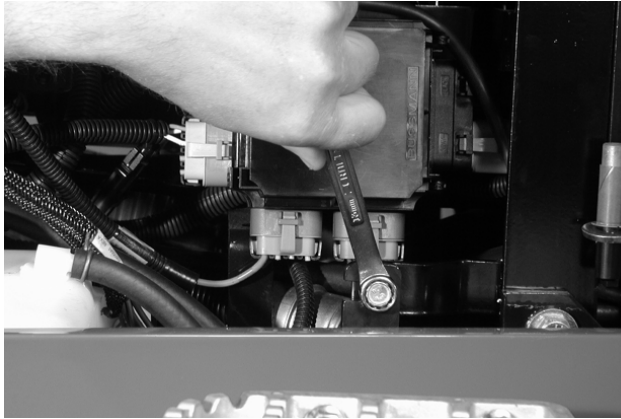
STEP 64

RD02F129

Install the left lower fixed hood panel.

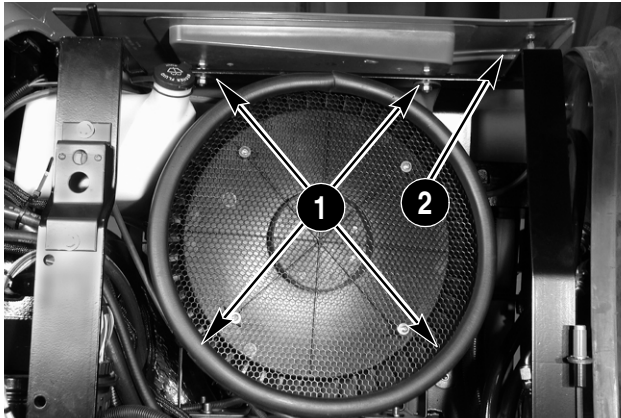
STEP 65

RD02E060

Install the fixed hood on the right side of the tractor. Install and tighten the four nuts (1). Install the front windshield washer hose (2) on the nozzle of the fixed hood. Install the air cleaner door on the left side of the tractor.

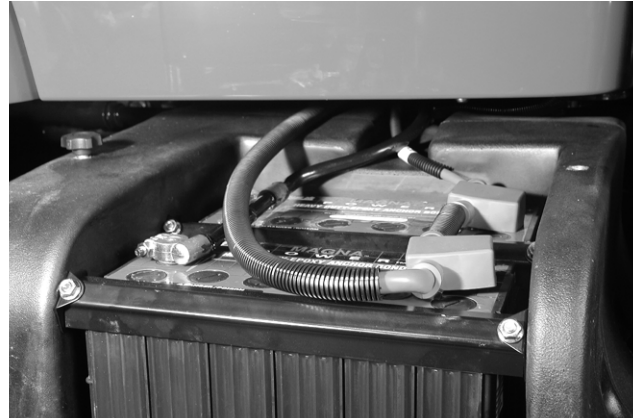
STEP 66

RD02E069

Connect the positive (+) battery cable, first. Connect the negative (-) battery cable. Install the battery cover and toolbox.

STEP 67

96R-28A

Remove the wheel blocks.

SPECIAL TORQUES

Bolts on cab steps 37 to 67 Nm (27 to 49 lb ft)

FUEL TANK

General

STEP 1



96R-28A

Before removing the fuel tank, do the following:

1. Park the tractor on a hard, level surface.
2. Place the transmission control lever in PARK.
3. Shut off the engine and remove the key.
4. Put blocks in front of and in back of the rear wheels.

Removal

STEP 2

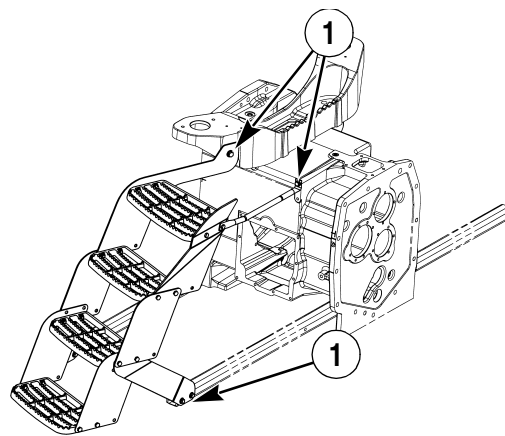

95-12

Remove the six step mounting bolts (1). Move the steps away from the tractor.

STEP 3

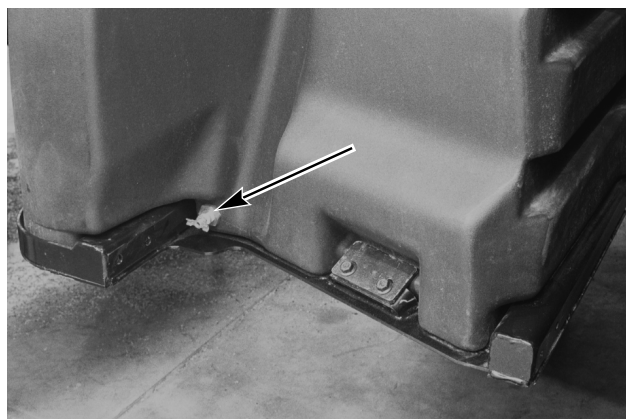

4-25F

Drain the fuel tank. Fuel tank capacities are listed in the chart below.

<u>Fuel Tank</u>	<u>210/230</u>	<u>255/285</u>
Standard	492 L (130 gal)	605 L (160 gal)
Optional	605 L (160 g)	

STEP 4



50-23F

Move the left rear wheel out on the axle as far as possible to provide clearance when removing the left tank. The wheel can also be removed.

STEP 7

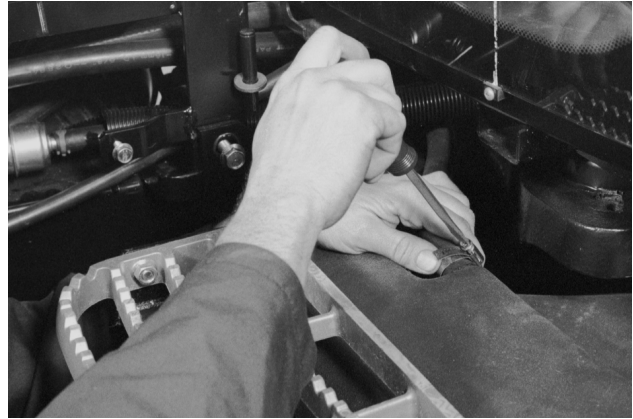

95-24-

Remove the pressure equalization hose at the front of the cab from the top left-hand fuel tank.

STEP 5

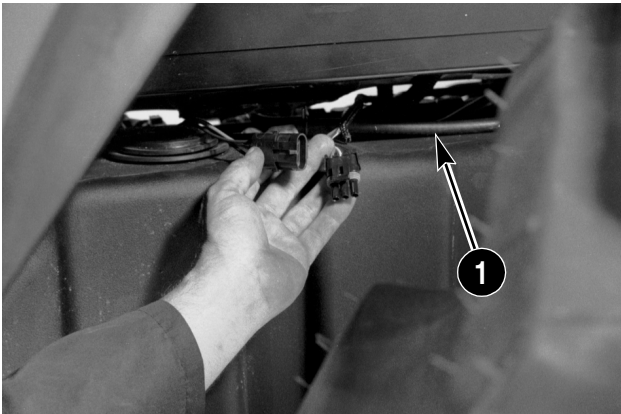

95-18

Disconnect the connector for the fuel level sending unit. Remove the fuel vent hose (1).

STEP 8



95-15R

Remove two bolts from each of the two lockdown plates.

STEP 6

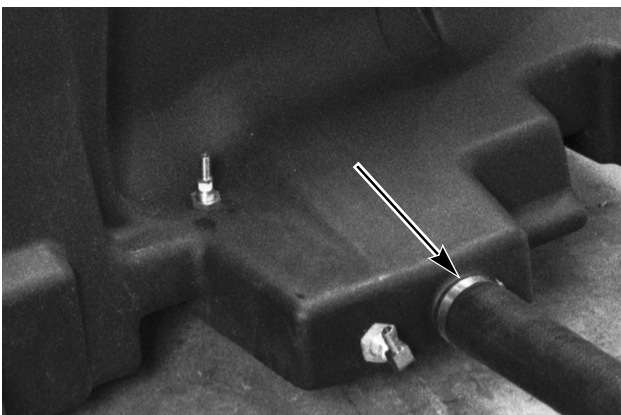

38-5ECU2

Loosen hose clamp on crossover hose from the bottom of the right fuel tank.

STEP 9



101R-19A

With prybars, lift up on the main tank and move it out a few inches. Insert a plug into the crossover hose as it comes off of the right tank. This will capture the remaining fuel in the tank.

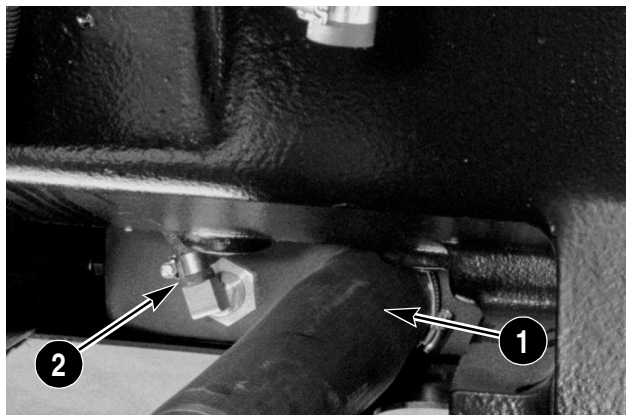
STEP 10

Disconnect the fuel supply line (2). Disconnect the fuel return line.

NOTE: Right tank removed for photographic purposes.

STEP 11

Remove the left tank.

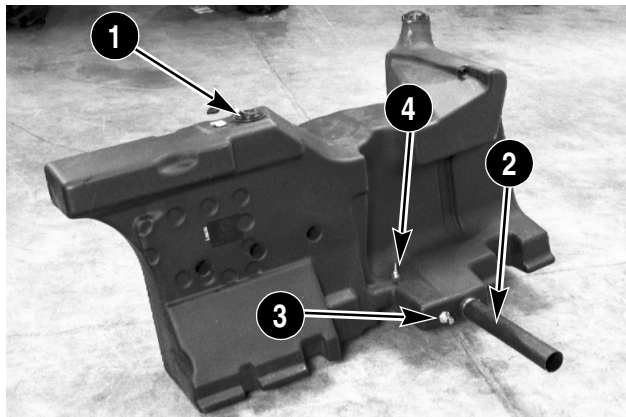
STEP 12

Remove the fuel level sending unit (1), crossover hose (2), fuel supply fitting (3) and the fuel return fitting (4).

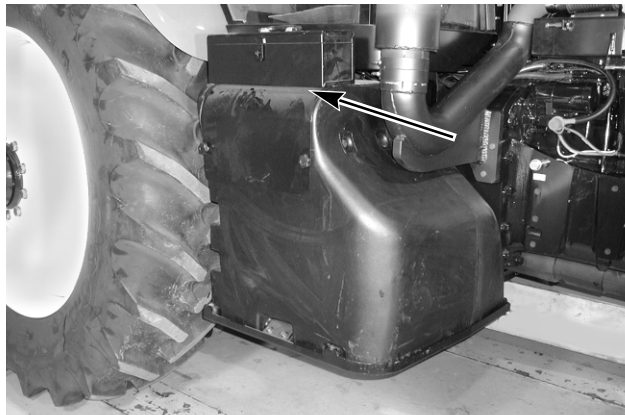
STEP 13

If the right tank is to be removed, remove the tool box and battery cover.

STEP 14

Remove the battery cables and move to the side. Remove the batteries.

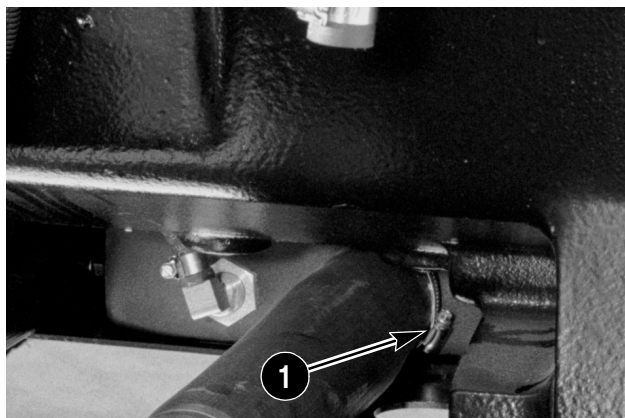
STEP 15

If not already removed, loosen the clamp (1) on the fuel crossover hose. Slip the hose off the neck leading into tank.

NOTE: Tank removed for photographic purposes.

STEP 16

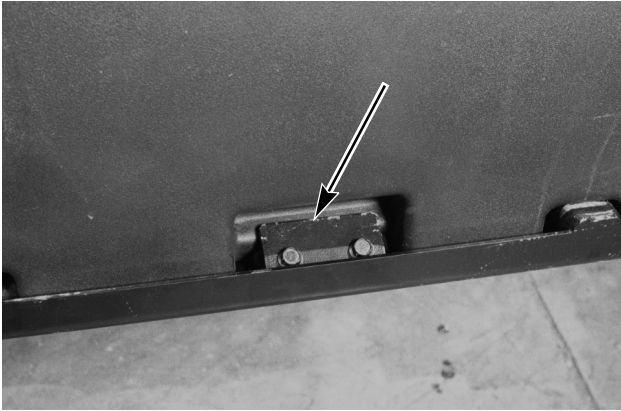

5-20

Remove the two bolts from the lockdown plate on the right tank.

STEP 17



101R-23A

Lift the right tank free of the support bracket and remove the tank.

STEP 18

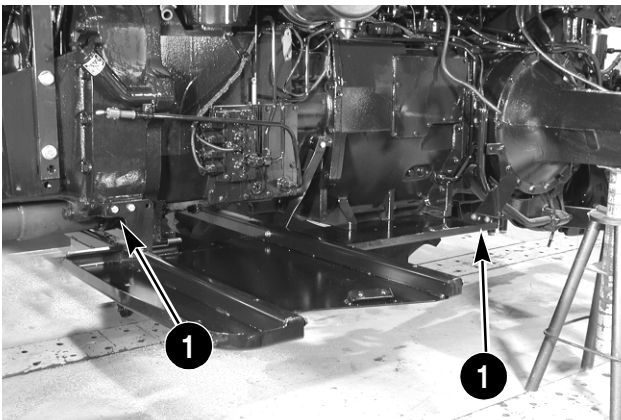

RD02B107

Use a jack to support the bottom of the tank support bracket while removing the bolts (1) from the left- and right-hand side of the bracket.

NOTE: Bolts are shown on left side.

Installation

STEP 19

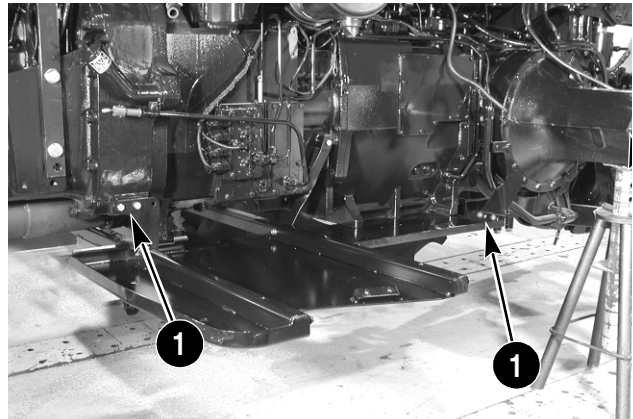

RD02B107

Use a jack to lift the support bracket into position and install and tighten all the retaining bolts (1).

NOTE: Left hand side shown.

STEP 20

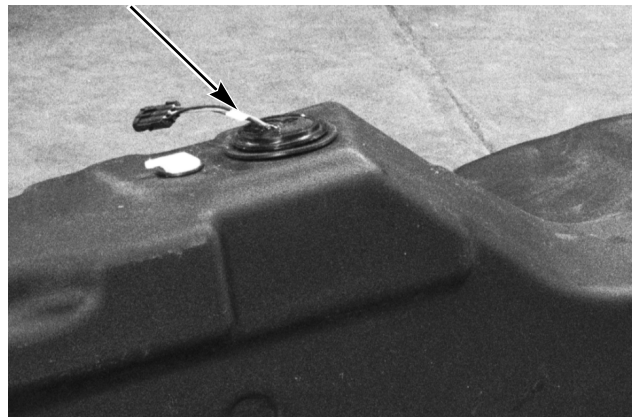

38-5ECU1

Install the fuel level sending unit. Connect the crossover hose on the left tank while on the floor.

STEP 21



101R-19A

Install the fuel tank onto the support brackets with enough room to attach fittings.

STEP 22

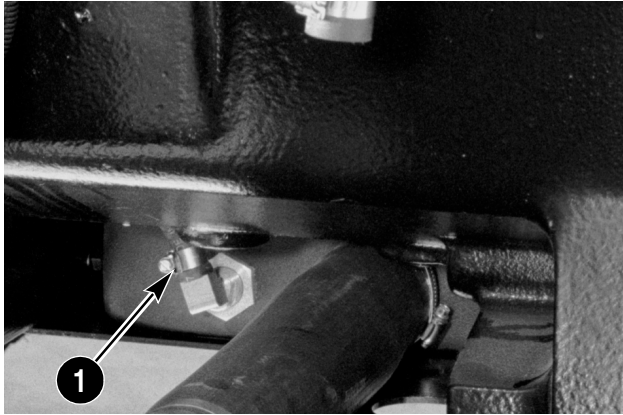

91-27CU

Connect the fuel supply hose (1) and fuel return hose.

STEP 25

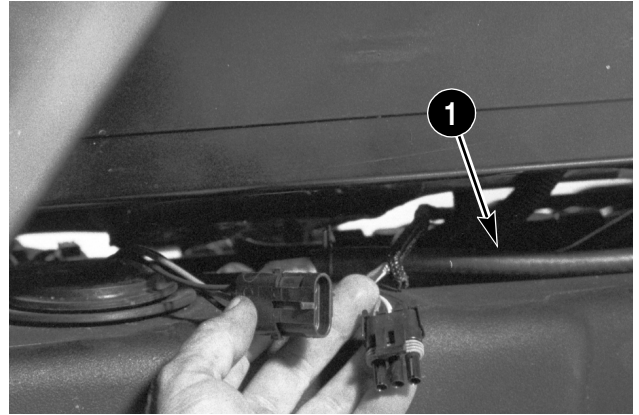

95-18ECU

Install the fuel vent hose (1) and reposition the hose clip. Install the connector for the fuel level sending unit by the fuel vent line.

STEP 23



95-15R

Move the left fuel tank into final position. Install and tighten two bolts through each of the two lockdown plates.

STEP 26



5-23

Position the wheels to the desired position on the rear axle.

STEP 24

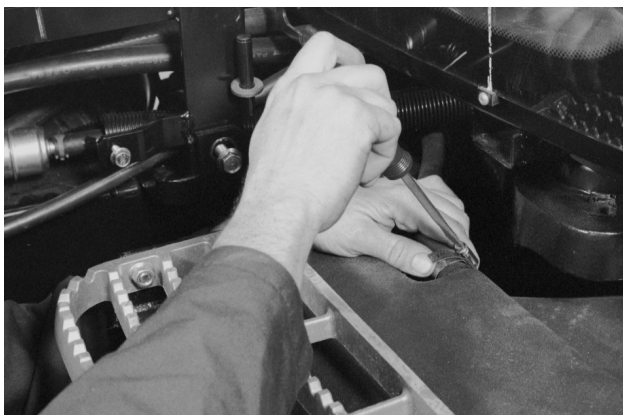

95-24

Install the pressure equalization hose on the top front of the left tank. Tighten clamp.

STEP 27



101R-23A

Move the right tank into position.



Suggest:

If the above button click is invalid.

Please download this document

first, and then click the above link

to download the complete manual.

Thank you so much for reading

STEP 28

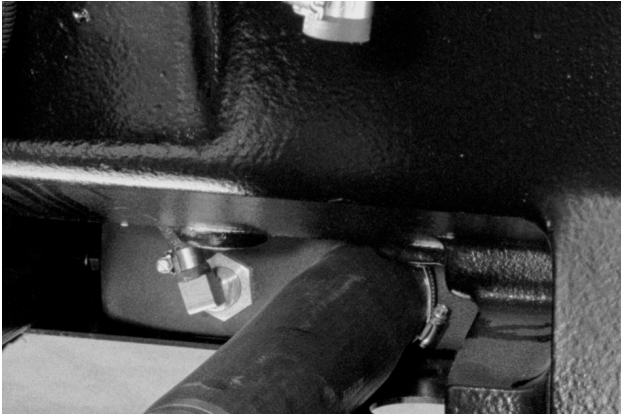

91-27CU

Connect the crossover hose (shown) and the loose end of the pressure equalization hose connected to the left tank.

STEP 29

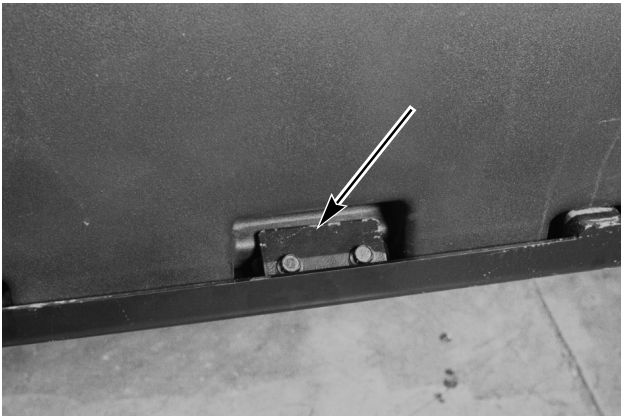

5-20

Install and tighten the two bolts on the hold-down plate.

STEP 30

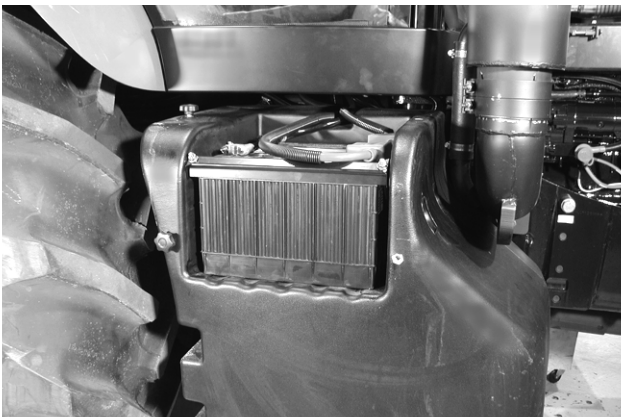

RD02B106

Install the batteries.

STEP 31

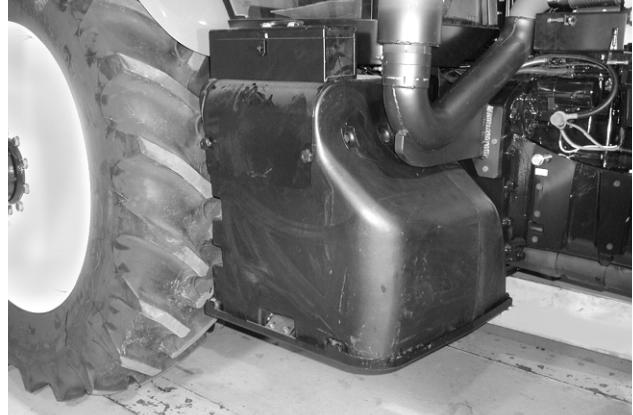

RD02B105

Install battery cover and toolbox.

STEP 32

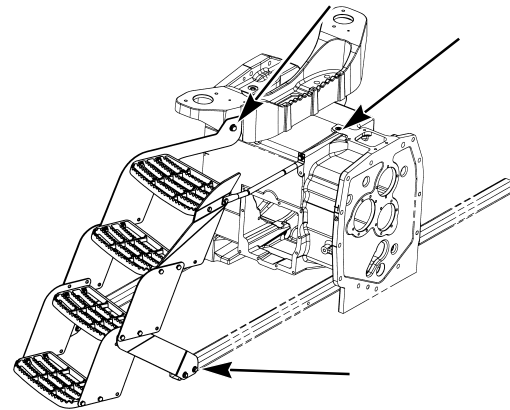

95-12

Move steps into position. Install six bolts and tighten to a torque of 37 to 67 Nm (27 to 49 lb ft).

STEP 33

Install fuel and check for leaks.

<https://www.ebooklibonline.com>

Hello dear friend!

Thank you very much for reading.

Enter the link into your browser.

The full manual is available for immediate download.

<https://www.ebooklibonline.com>