

MAXXUM® 115 / MAXXUM® 115 Multicontroller / MAXXUM® CVT 115
MAXXUM® 125 / MAXXUM® 125 Multicontroller / MAXXUM® CVT 125
MAXXUM® 135 / MAXXUM® 135 Multicontroller / MAXXUM® CVT 135
MAXXUM® 145 / MAXXUM® 145 Multicontroller / MAXXUM® CVT 145
MAXXUM® 150 / MAXXUM® 150 Multicontroller
Tier 4B (final)
Tractor

SERVICE MANUAL

Part number 47938724

1st edition English

October 2015

CASE II
AGRICULTURE



SERVICE MANUAL

**MAXXUM® 115 Multicontroller , MAXXUM® 115 , MAXXUM® 125
Multicontroller , MAXXUM® 125 , MAXXUM® 135 Multicontroller , MAXXUM®
135 , MAXXUM® 145 Multicontroller , MAXXUM® 145 , MAXXUM® 150
Multicontroller , MAXXUM® 150 , MAXXUM® CVT 115 , MAXXUM® CVT 125 ,
MAXXUM® CVT 135 , MAXXUM® CVT 145**

Link Product / Engine

Product	Market Product	Engine
MAXXUM® CVT 115	North America	F4DFE4134*B005
MAXXUM® CVT 125	North America	F4DFE4133*B007
MAXXUM® CVT 135	North America	F4DFE4132*B005
MAXXUM® CVT 145	North America	F4DFE4131*B007
MAXXUM® 115	North America	F4DFE4134*B006
MAXXUM® 115 Multicontroller	North America	F4DFE4134*B006
MAXXUM® 125	North America	F4DFE4133*B008
MAXXUM® 125 Multicontroller	North America	F4DFE4133*B008
MAXXUM® 135	North America	F4DFE4132*B006
MAXXUM® 135 Multicontroller	North America	F4DFE4132*B006
MAXXUM® 145	North America	F4DFE4131*B008
MAXXUM® 145 Multicontroller	North America	F4DFE4131*B008
MAXXUM® 150	North America	F4DFE6132*B007
MAXXUM® 150 Multicontroller	North America	F4DFE6132*B007

<https://www.ebooklibonline.com>

Hello dear friend!

Thank you very much for reading.

Enter the link into your browser.

The full manual is available for immediate download.

<https://www.ebooklibonline.com>

Contents

INTRODUCTION

Engine	10
[10.001] Engine and crankcase	10.1
[10.216] Fuel tanks	10.2
[10.202] Air cleaners and lines	10.3
[10.254] Intake and exhaust manifolds and muffler	10.4
[10.500] Selective Catalytic Reduction (SCR) exhaust treatment.....	10.5
[10.400] Engine cooling system	10.6
[10.414] Fan and drive	10.7
[10.310] Aftercooler.....	10.8
[10.304] Engine lubrication system.....	10.9
Clutch	18
[18.112] Slip clutch or flywheel damper	18.1
Transmission	21
[21.111] Semi-Powershift transmission	21.1
[21.133] Semi-Powershift transmission external controls	21.2
[21.103] Semi-Powershift transmission lubrication system.....	21.3
[21.152] Semi-Powershift transmission internal components	21.4
[21.504] Continuously Variable Transmission (CVT)	21.5
[21.505] Continuously Variable Transmission (CVT) external controls.....	21.6
[21.506] Continuously Variable Transmission (CVT) lubrication system	21.7
[21.507] Continuously Variable Transmission (CVT) internal components.....	21.8
[21.160] Creeper	21.9
[21.166] Overdrive.....	21.10
Four-Wheel Drive (4WD) system	23
[23.202] Electro-hydraulic control	23.1

[23.314] Drive shaft.....	23.2
Front axle system	25
[25.100] Powered front axle	25.1
[25.102] Front bevel gear set and differential	25.2
[25.108] Final drive hub, steering knuckles, and shafts	25.3
[25.122] Axle suspension control.....	25.4
Rear axle system.....	27
[27.100] Powered rear axle.....	27.1
[27.106] Rear bevel gear set and differential.....	27.2
[27.120] Planetary and final drives	27.3
Power Take-Off (PTO).....	31
[31.104] Rear electro-hydraulic control.....	31.1
[31.114] Two-speed rear Power Take-Off (PTO)	31.2
[31.116] Three-speed rear Power Take-Off (PTO)	31.3
[31.142] Front Power Take-Off (PTO) control	31.4
[31.146] Front Power Take-Off (PTO)	31.5
Brakes and controls	33
[33.202] Hydraulic service brakes	33.1
[33.110] Parking brake or parking lock	33.2
[33.220] Trailer brake hydraulic control.....	33.3
[33.224] Trailer brake pneumatic control	33.4
[33.204] Front axle brake	33.5
Hydraulic systems.....	35
[35.000] Hydraulic systems.....	35.1
[35.300] Reservoir, cooler, and filters.....	35.2
[35.104] Fixed displacement pump.....	35.3
[35.106] Variable displacement pump	35.4
[35.105] Charge pump.....	35.5

[35.322] Regulated/Low pressure system	35.6
[35.204] Remote control valves	35.7
[35.220] Auxiliary hydraulic pump	35.8
[35.114] Three-point hitch control valve	35.9
[35.116] Three-point hitch cylinder	35.10
[35.160] Front hitch controls and lines	35.11
Hitches, drawbars, and implement couplings	37
[37.120] Rear three-point hitch linkage	37.1
Frames and ballasting	39
[39.100] Frame	39.1
Steering	41
[41.101] Steering control	41.1
[41.106] Tie rods	41.2
[41.200] Hydraulic control components	41.3
[41.206] Pump	41.4
[41.216] Cylinders	41.5
[41.432] Autoguidance steering	41.6
Wheels	44
[44.511] Front wheels	44.1
[44.520] Rear wheels	44.2
Cab climate control	50
[50.100] Heating	50.1
[50.104] Ventilation	50.2
[50.200] Air conditioning	50.3
Electrical systems	55
[55.000] Electrical system	55.1
[55.100] Harnesses and connectors	55.2

[55.015] Engine control system.....	55.3
[55.301] Alternator.....	55.4
[55.302] Battery.....	55.5
[55.014] Engine intake and exhaust system.....	55.6
[55.988] Selective Catalytic Reduction (SCR) electrical system	55.7
[55.640] Electronic modules.....	55.8
[55.024] Transmission control system.....	55.9
[55.020] Transmission speed sensors.....	55.10
[55.021] Transmission pressure sensors.....	55.11
[55.022] Transmission temperature sensors	55.12
[55.023] Transmission position sensors.....	55.13
[55.048] Rear Power Take-Off (PTO) control system	55.14
[55.031] Parking brake electrical system.....	55.15
[55.512] Cab controls.....	55.16
[55.035] Remote control valve electric control	55.17
[55.051] Cab Heating, Ventilation, and Air-Conditioning (HVAC) controls.....	55.18
[55.050] Heating, Ventilation, and Air-Conditioning (HVAC) control system.....	55.19
[55.047] Steering control system.....	55.20
[55.130] Rear three-point hitch electronic control system.....	55.21
[55.911] Global Positioning System (GPS).....	55.22
[55.405] External lighting switches and relays	55.23
[55.510] Cab or platform harnesses and connectors.....	55.24
[55.408] Warning indicators, alarms, and instruments	55.25
[55.DTC] FAULT CODES.....	55.26

Platform, cab, bodywork, and decals..... 90

[90.150] Cab.....	90.1
[90.100] Engine hood and panels	90.2



INTRODUCTION

Foreword - Important notice regarding equipment servicing

All repair and maintenance work listed in this manual must be carried out only by qualified dealership personnel, strictly complying with the instructions given, and using, whenever possible, the special tools.

Anyone who performs repair and maintenance operations without complying with the procedures provided herein shall be responsible for any subsequent damages.

The manufacturer and all the organizations of its distribution chain, including - without limitation - national, regional, or local dealers, reject any responsibility for damages caused by parts and/or components not approved by the manufacturer, including those used for the servicing or repair of the product manufactured or marketed by the manufacturer. In any case, no warranty is given or attributed on the product manufactured or marketed by the manufacturer in case of damages caused by parts and/or components not approved by the manufacturer.

The manufacturer reserves the right to make improvements in design and changes in specifications at any time without notice and without incurring any obligation to install them on units previously sold. Specifications, descriptions, and illustrative material herein are as accurate as known at time of publication but are subject to change without notice.

In case of questions, refer to your CASE IH Sales and Service Networks.

Foreword - How to use and navigate through this manual

This manual has been produced by a new technical information system. This new system is designed to deliver technical information electronically through web delivery (eTIM), DVD, and paper manuals. A coding system called SAP has been developed to link the technical information to other Product Support functions, e.g., Warranty.

Technical information is written to support the maintenance and service of the functions or systems on a customer's machine. When a customer has a concern on their machine it is usually because a function or system on their machine is not working at all, is not working efficiently, or is not responding correctly to their commands. When you refer to the technical information in this manual to resolve that customer's concern, you will find all the information classified using the SAP coding, according to the functions or systems on that machine. Once you have located the technical information for that function or system, you will then find all the mechanical, electrical or hydraulic devices, components, assemblies, and sub assemblies for that function or system. You will also find all the types of information that have been written for that function or system: the technical data (specifications), the functional data (how it works), the diagnostic data (fault codes and troubleshooting), and the service data (remove, install adjust, etc.).

By integrating SAP coding into technical information, you will be able to search and retrieve just the right piece of technical information you need to resolve that customer's concern on his machine. This is made possible by attaching 3 categories to each piece of technical information during the authoring process.

The first category is the Location, the second category is the Information Type and the third category is the Product:

- LOCATION - the component or function on the machine, that the piece of technical information is going to describe (e.g., Fuel tank).
- INFORMATION TYPE - the piece of technical information that has been written for a particular component or function on the machine (e.g., Capacity would be a type of Technical Data describing the amount of fuel held by the fuel tank).
- PRODUCT - the model for which the piece of technical information is written.

Every piece of technical information will have those three categories attached to it. You will be able to use any combination of those categories to find the right piece of technical information you need to resolve that customer's concern on their machine.

That information could be:

- the procedure for how to remove the cylinder head
- a table of specifications for a hydraulic pump
- a fault code
- a troubleshooting table
- a special tool

Manual content

This manual is divided into Sections. Each Section is then divided into Chapters. Contents pages are included at the beginning of the manual, then inside every Section and inside every Chapter. An alphabetical Index is included at the end of each Chapter. Page number references are included for every piece of technical information listed in the Chapter Contents or Chapter Index.

Each Chapter is divided into four Information types:

- Technical Data (specifications) for all the mechanical, electrical or hydraulic devices, components, assemblies or sub-assemblies.
- Functional Data (how it works) for all the mechanical, electrical or hydraulic devices, components, assemblies or sub-assemblies.
- Diagnostic Data (fault codes, electrical and hydraulic troubleshooting) for all the mechanical, electrical or hydraulic devices, components, assemblies or sub-assemblies.
- Service Data (remove disassemble, assemble, install) for all the mechanical, electrical or hydraulic devices, components, assemblies or sub-assemblies.

Sections

Sections are grouped according to the main functions or a systems on the machine. Each Section is identified by a number (00, 35, 55, etc.). The Sections included in the manual will depend on the type and function of the machine that the manual is written for. Each Section has a Contents page listed in alphabetic/numeric order. This table illustrates which Sections could be included in a manual for a particular product.

SECTION	PRODUCT					
	Tractors					
	Vehicles with working arms: backhoes, excavators, skid steers,					
	Combines, forage harvesters, balers,					
	Seeding, planting, floating, spraying equipment,					
Mounted equipment and tools,						
00 - Maintenance	X	X	X	X	X	
05 - Machine completion and equipment	X	X	X	X	X	
10 - Engine	X	X	X	X		
14 - Main gearbox and drive	X	X	X	X		
18 - Clutch	X	X	X			
21 - Transmission	X	X	X	X		
23 - Four wheel drive (4WD) system	X	X	X	X		
25 - Front axle system	X	X	X	X		
27 - Rear axle system	X	X	X	X		
29 - Hydrostatic drive	X	X	X	X		
31 - Power Take-Off (PTO)	X		X			
33 - Brakes and controls	X	X	X	X		
35 - Hydraulic systems	X	X	X	X		
36 - Pneumatic system	X	X	X	X		
37 - Hitches, drawbars and implement couplings	X		X	X		
39 - Frames and ballasting	X	X	X	X	X	
41 - Steering	X	X	X	X		
44 - Wheels	X	X	X	X		
46 - Steering clutches						
48 - Tracks and track suspension	X	X	X			
50 - Cab climate control	X	X	X	X		
55 - Electrical systems	X	X	X	X	X	
56 - Grape harvester shaking						
58 - Attachments/headers			X			
60 - Product feeding			X			

INTRODUCTION

61 - Metering system				X	
62 - Pressing - Bale formation			X		
63 - Chemical applicators				X	
64 - Chopping			X		
66 - Threshing			X		
68 - Tying/Wrapping/Twisting			X		
69 - Bale wagons					
70 - Ejection			X		
71 - Lubrication system	X	X	X	X	X
72 - Separation			X		
73 - Residue handling			X		
74 - Cleaning			X		
75 - Soil preparation/Finishing					
76 - Secondary cleaning / Destemmer					
77 - Seeding				X	
78 - Spraying				X	
79 - Planting				X	
80 - Crop storage / Unloading			X		
82 - Front loader and bucket	X	X			
83 - Telescopic single arm	X	X			
84 - Booms, dippers and buckets	X	X			
86 - Dozer blade and arm	X	X			
88 - Accessories	X	X	X	X	X
89 - Tools	X	X	X	X	X
90 - Platform, cab, bodywork and decals	X	X	X	X	



SERVICE MANUAL

Engine

**MAXXUM® 115 Multicontroller , MAXXUM® 115 , MAXXUM® 125
Multicontroller , MAXXUM® 125 , MAXXUM® 135 Multicontroller , MAXXUM®
135 , MAXXUM® 145 Multicontroller , MAXXUM® 145 , MAXXUM® 150
Multicontroller , MAXXUM® 150 , MAXXUM® CVT 115 , MAXXUM® CVT 125 ,
MAXXUM® CVT 135 , MAXXUM® CVT 145**

Engine - Disconnect

MAXXUM® 115 Multicontroller	NA
MAXXUM® 115	NA
MAXXUM® 125 Multicontroller	NA
MAXXUM® 125	NA
MAXXUM® 135 Multicontroller	NA
MAXXUM® 135	NA
MAXXUM® 145 Multicontroller	NA
MAXXUM® 145	NA
MAXXUM® 150 Multicontroller	NA
MAXXUM® 150	NA

Prior operation:

Discharge the air conditioning system, see **Air conditioning - Discharging (50.200)**.

Prior operation:

Disconnect the battery, see **Battery - Disconnect (55.302)**.

Prior operation:

Drain the engine cooling system, see **Engine cooling system - Drain fluid (10.400)**.

Prior operation:

Remove the selective catalytic reduction (SCR) muffler, see **Selective Catalytic Reduction (SCR) muffler and catalyst - Remove (10.500)**.

Prior operation:

Remove the left-hand fuel tank, see **Fuel tank - Remove (10.216)**.

Prior operation:

Remove the coolant control valve, see **Coolant control valve - Remove (10.500)**.

WARNING

Heavy objects!

Lift and handle all heavy components using lifting equipment with adequate capacity. Always support units or parts with suitable slings or hooks. Make sure the work area is clear of all bystanders.

Failure to comply could result in death or serious injury.

W0398A

WARNING

Avoid injury!

Handle all parts carefully. Do not place your hands or fingers between parts. Use Personal Protective Equipment (PPE) as indicated in this manual, including protective goggles, gloves, and safety footwear.

Failure to comply could result in death or serious injury.

W0208A

All vehicles

1. **⚠ WARNING**

Crushing hazard!
The wheels on this vehicle are very heavy. Always use a wheel remover or chain hoists to remove and install the wheels. Use an assistant as required.
Failure to comply could result in death or serious injury.

W0149A

Install the left-hand rear wheel.

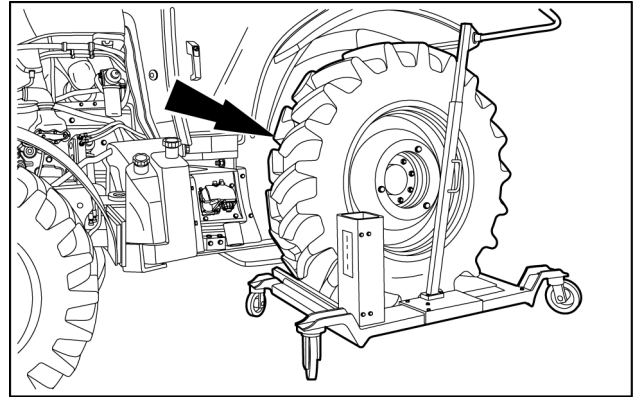

BAIL14TR00881AB 1

2. Drain the transmission oil.

- A. Remove the transmission housing drain plug and drain the transmission oil into a suitable container.
- B. Install the drain plug and torque to **68 - 82 N·m (50 - 60 lb ft)**.

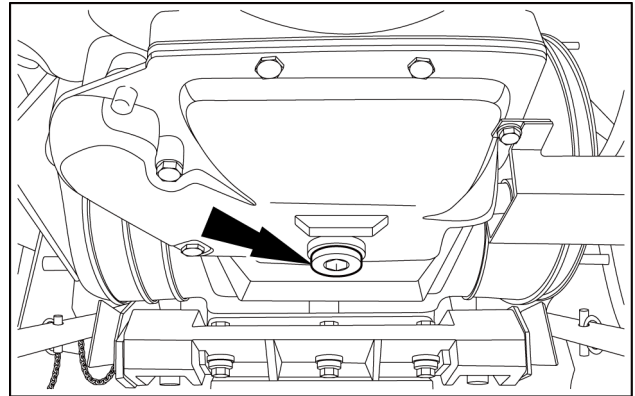

BAIL14TR00962AB 2

Vehicles with front hitch

3. Disconnect the front hitch hydraulic pipes from the mid-mount valve.

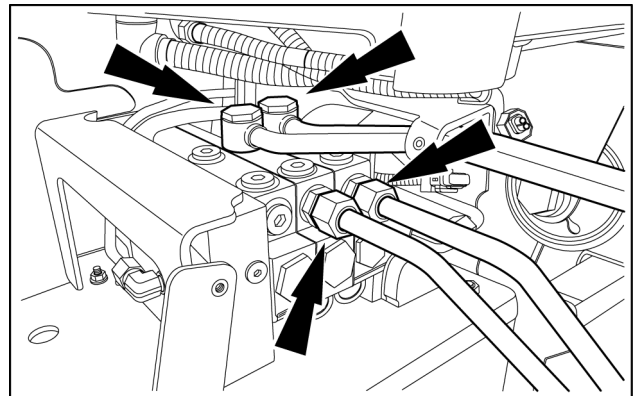

BAIL13TR01645AB 3

4. Remove the front hitch hydraulic pipes.

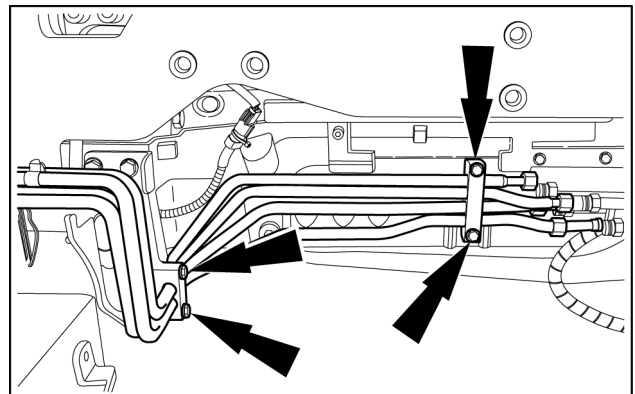

BAIL13TR01647AB 4

5. 1. Disconnect the radar electrical connector (if equipped).
2. Remove the radar (if equipped).

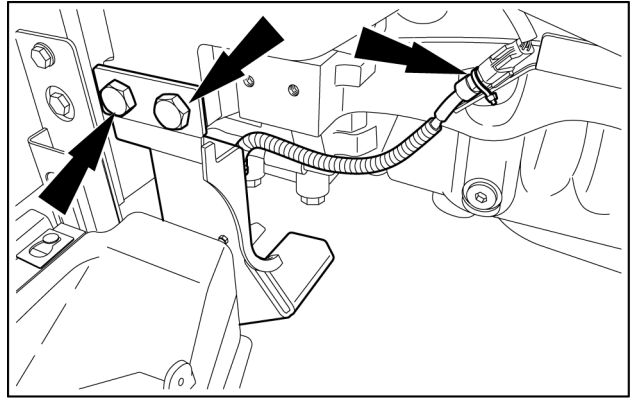

BAIL13TR01648AB 5

6. **⚠ WARNING**
Heavy object!
ALWAYS use a hoist or get assistance to lift the component.
Failure to comply could result in death or serious injury.

W0086A

Remove the right-hand side rail.

NOTE: Repeat this step for the left-hand side.

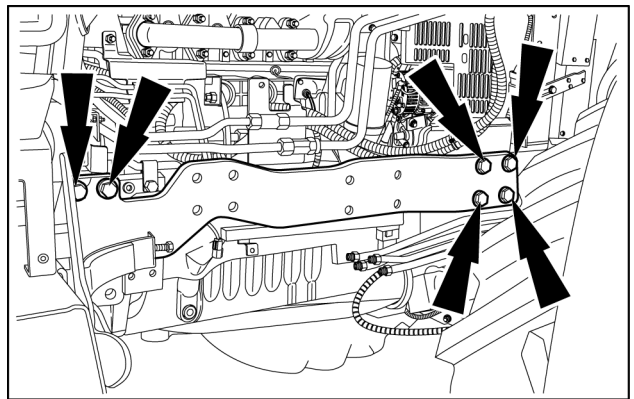

BAIL13TR01649AB 6

All vehicles

7. Disconnect the oil cooler supply and return pipes.

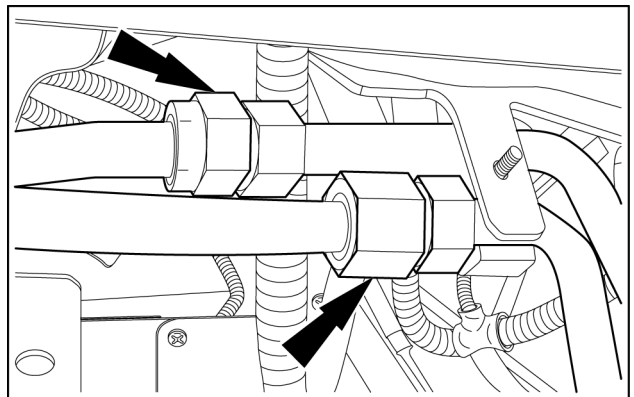

BAIL14TR00882AB 7

8. Remove the oil cooler supply and return pipes.

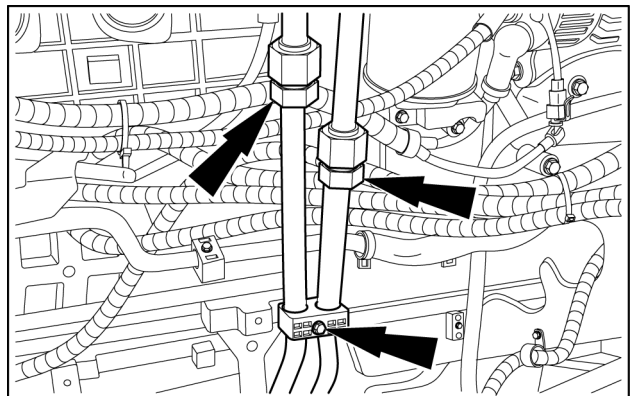

BAIL14TR00883AB 8

9. Detach the fuse box.

- A. Remove the retaining nuts.
- B. Detach the wiring harnesses from the retaining clips.

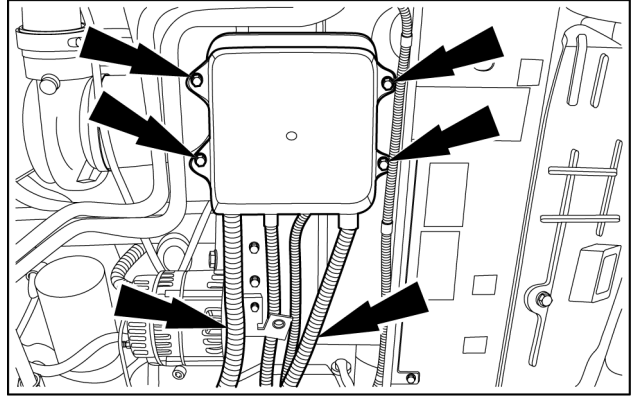

BAIL14TR00935AB 9

10. • Disconnect the alternator electrical connector.
• Disconnect the in-line electrical connector.

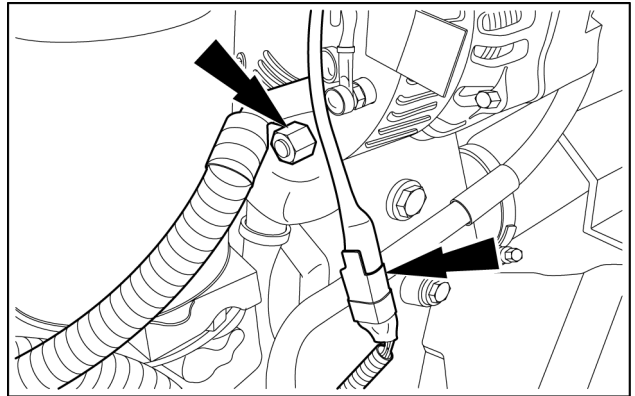

BAIL14TR00936AB 10

11. Remove the side panel mounting bracket.

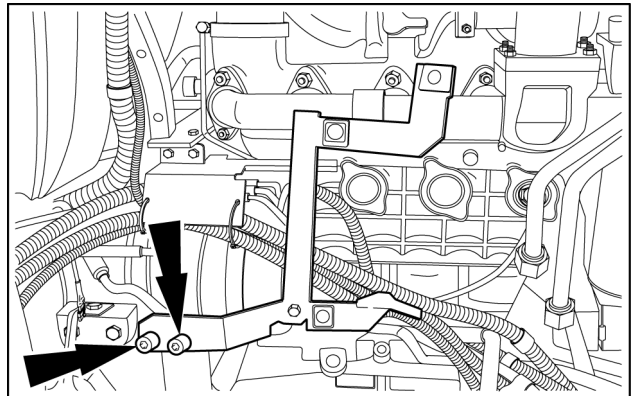

BAIL14TR00937AB 11

12. Remove the starter motor shield.

- A. Cut the cable ties.
- B. Remove the starter motor shield retaining bolts.

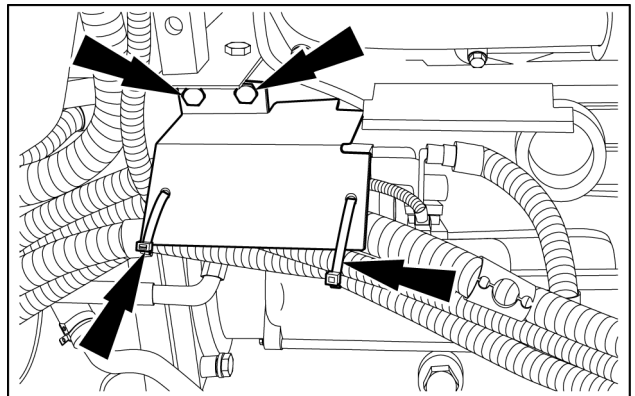

BAIL14TR00938AB 12

13. Disconnect the starter motor electrical connectors.

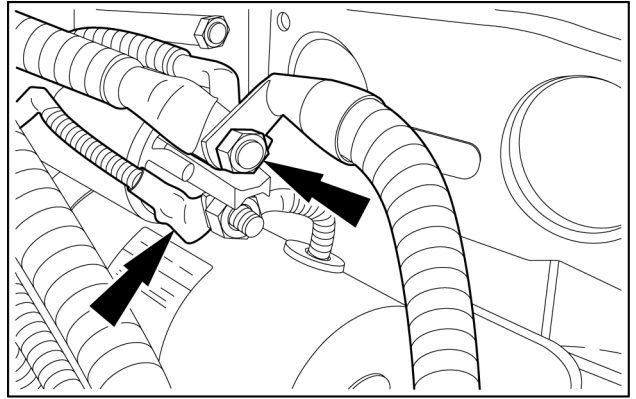

BAIL14TR00884AB 13

14. 1. Disconnect the starter motor negative terminal.
2. Disconnect the cab heater supply pipe.
3. Detach the cab heater supply pipe.

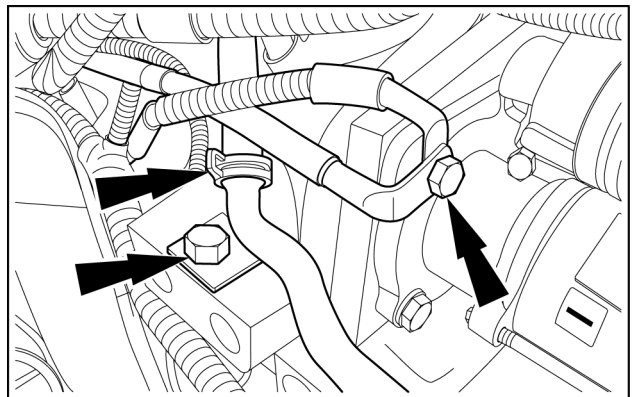

BAIL14TR00885AB 14

15. Detach the cab heater supply pipe.

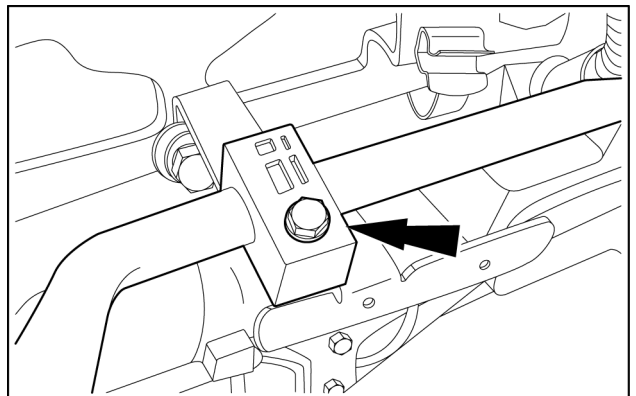

BAIL14TR00886AB 15

16. Disconnect the block heater electrical connector (if equipped).

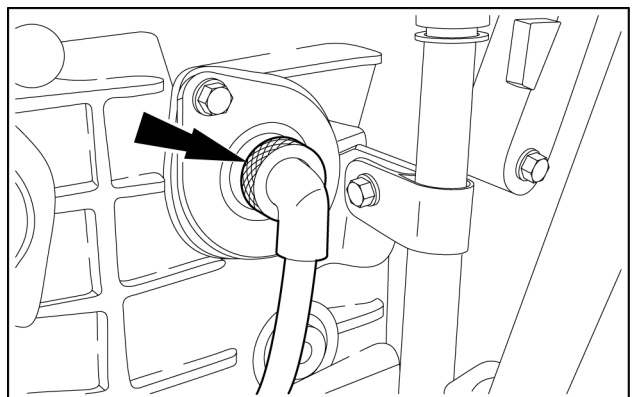

BAIL14TR00887AB 16

17. Disconnect the heater supply hose from the rear of the cylinder head.

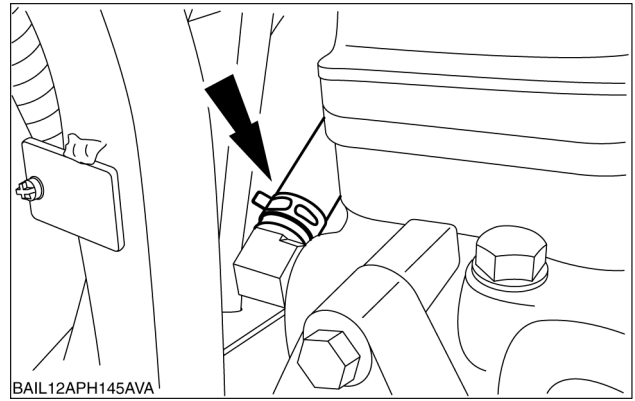

BAIL12APH145AVA 17

18. Disconnect the engine breather pipe.

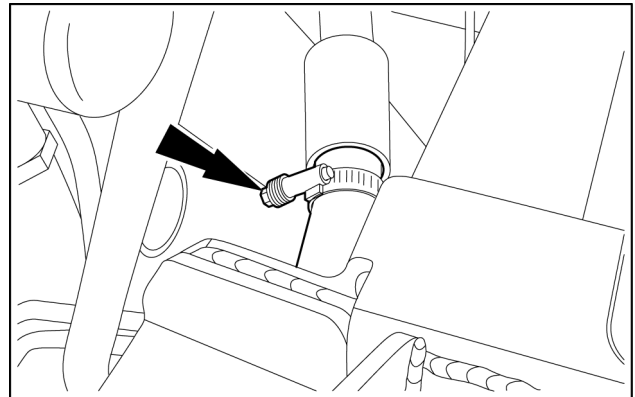

BAIL14TR00888AB 18

19. 1. Disconnect the brake fluid reservoir electrical connector.
2. Remove the brake fluid reservoir heat shield.

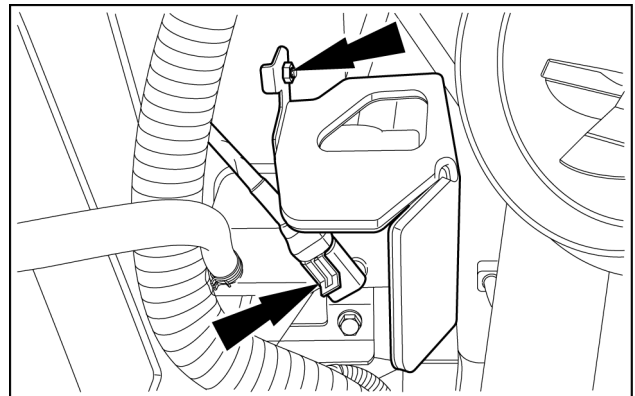

BAIL15TR00026AA 19

20. Detach the brake fluid reservoir and position it to one side.

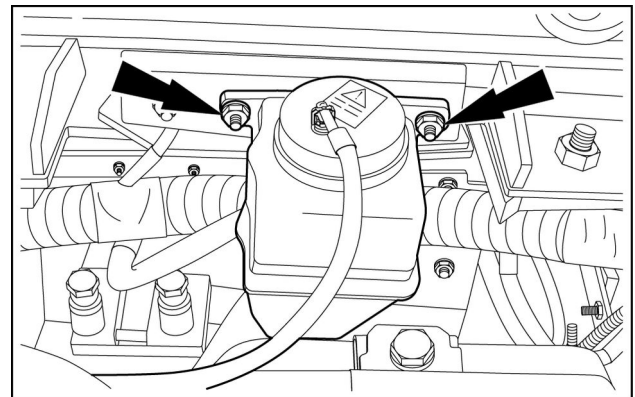

BAIL14TR00939AB 20

21. Disconnect the steering pipes.

NOTE: Mark the pipes to aid installation.

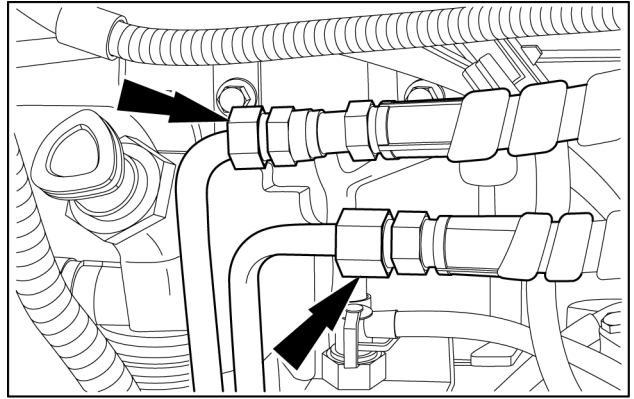

BAIL14TR00940AB 21

22. Remove the fuel line.

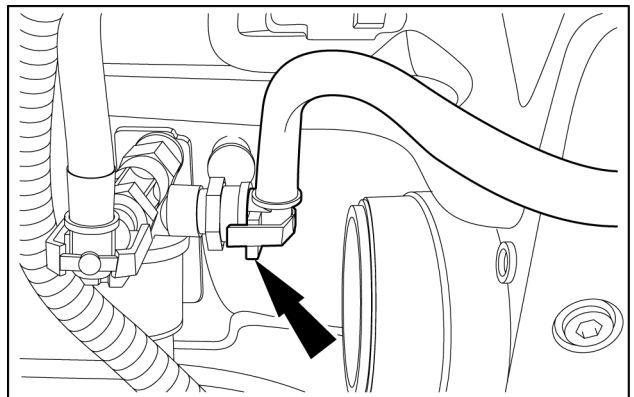

BAIL14TR00941AB 22

23. 1. Disconnect the electrical connector (1).
2. Detach the wiring harness (2) from the bracket.
3. Remove the bracket.

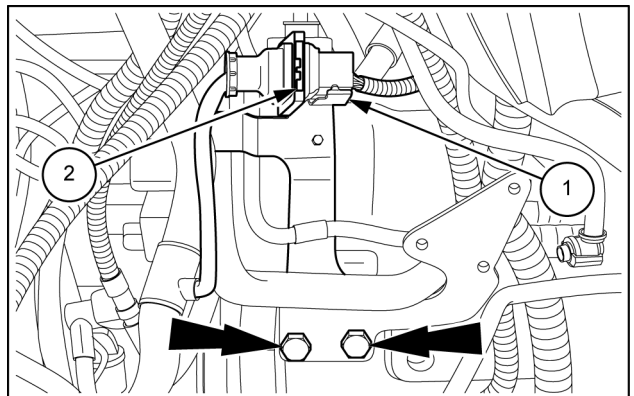

BAIL14TR00943AB 23

24. Disconnect the in-line electrical connector.

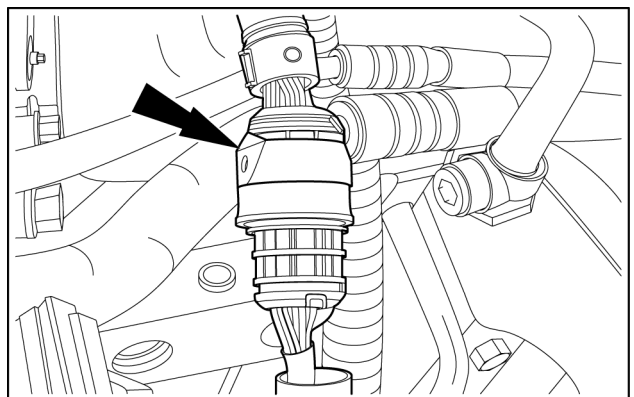

BAIL14TR00944AB 24

25. Remove the aftercooler left-hand hose.

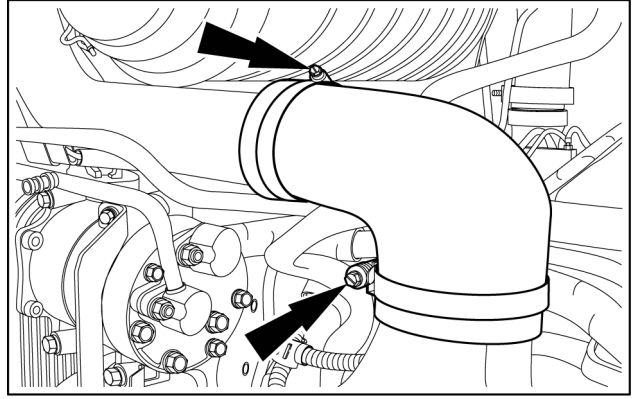

BAIL14TR00945AB 25

26. 1. Detach the electrical connector from the air-conditioning pipe.
2. Disconnect the air-conditioning in-line pipe.
3. Disconnect the air-conditioning compressor pipe.

NOTE: Seal all openings using clean blanking caps.

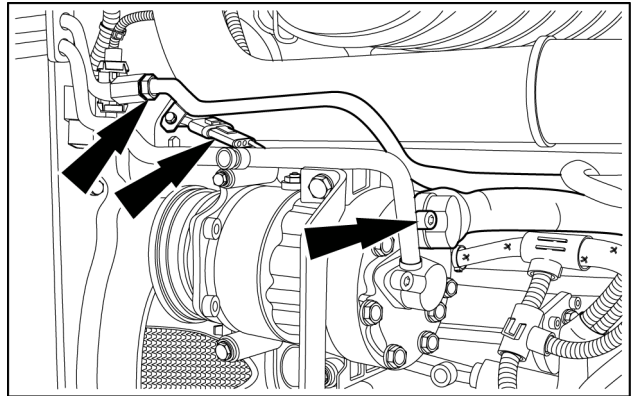

BAIL14TR00946AB 26

27. • Disconnect the ground cable.
• Disconnect the in-line electrical connector.
• Disconnect the fuel line.

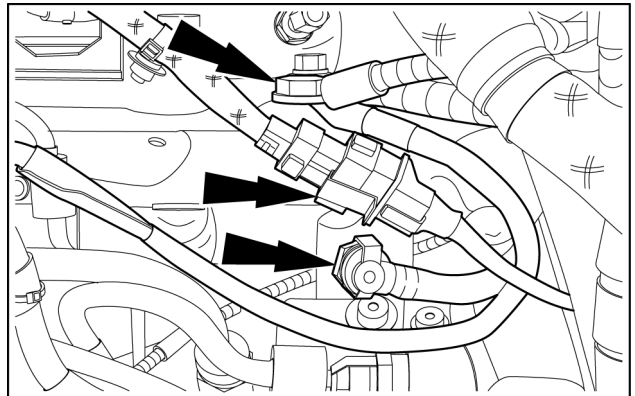

BAIL14TR00947AB 27

28. Disconnect the water-in-fuel electrical connector.

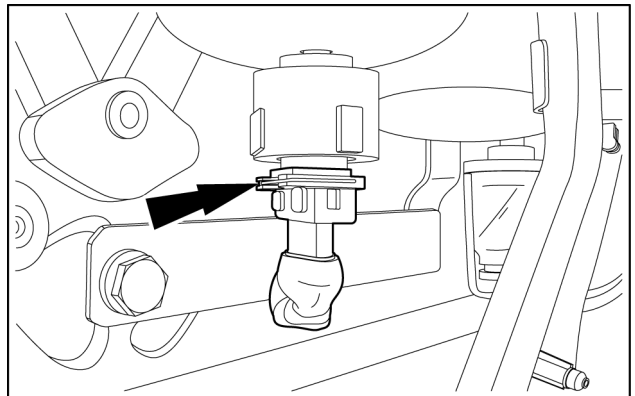

BAIL14TR00948AB 28

29. Disconnect the differential lock supply pipe.

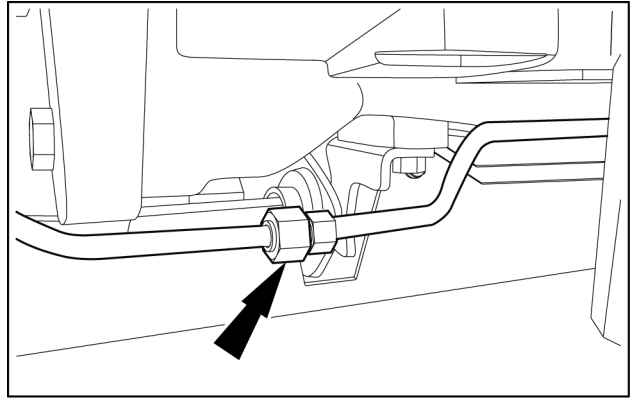

BAIL14TR00949AB 29

30. 1. Disconnect the in-line electrical connector.
2. Detach the wiring harness from the clip.
3. Cut the cable tie.

NOTICE: Seal all openings using clean blanking plugs.

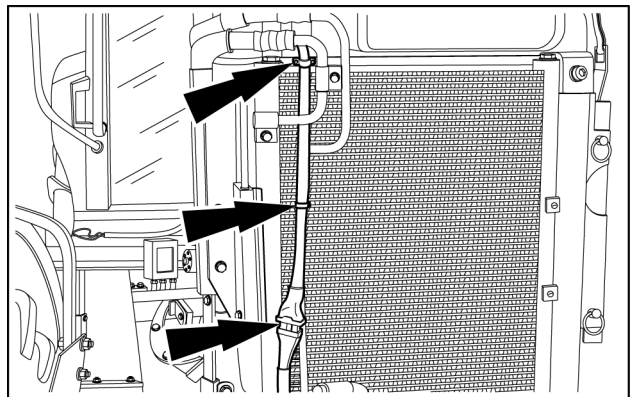

BAIL14TR00950AB 30

31. Remove the upper shroud.

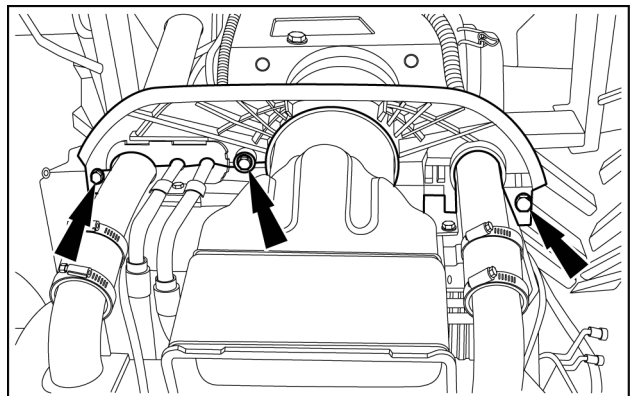

BAIL14TR00951AB 31

32. 1. Disconnect the in-line electrical connector.
2. Detach the wiring harness from the clip.

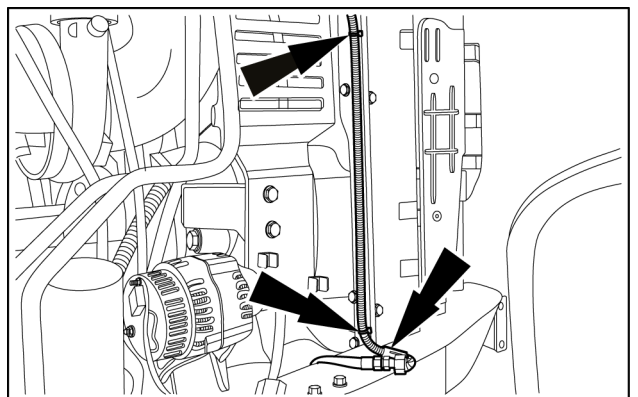

BAIL14TR00952AB 32

33. • Disconnect the air intake temperature (IAT) sensor electrical connector.
• Detach the wiring harness from the clips.

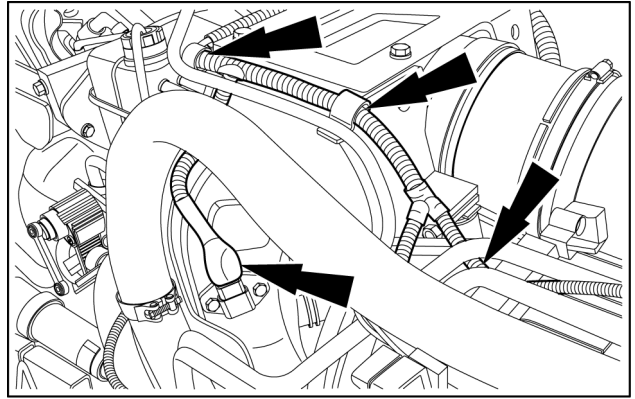

BAIL14TR00953AB 33

34. Disconnect the air cleaner sensor electrical connectors.

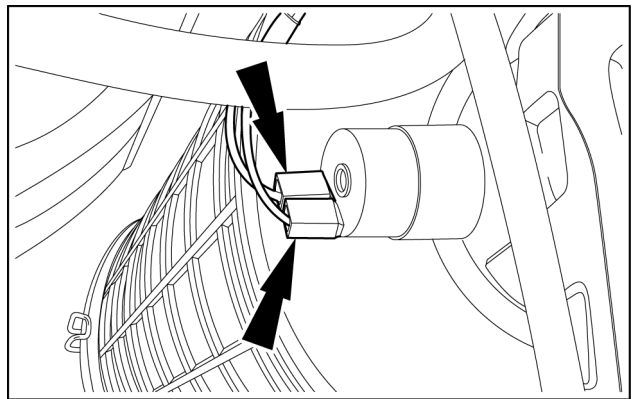

BAIL14TR00961AB 34

35. Disconnect the dosing module electrical connector.

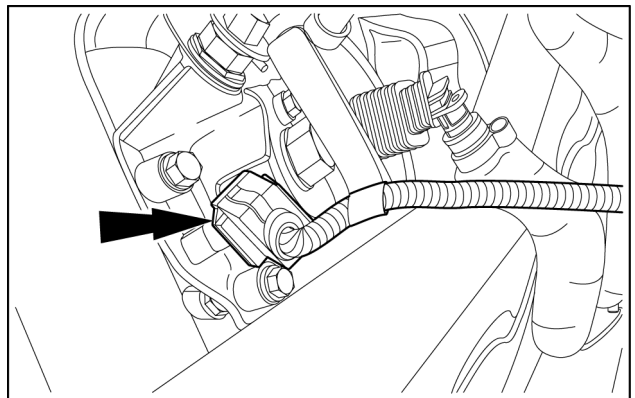

BAIL14TR00954AB 35

36. • Disconnect the nitrogen oxide (NOx) amplifier electrical connector.
• Disconnect the air-conditioning compressor in-line electrical connector.

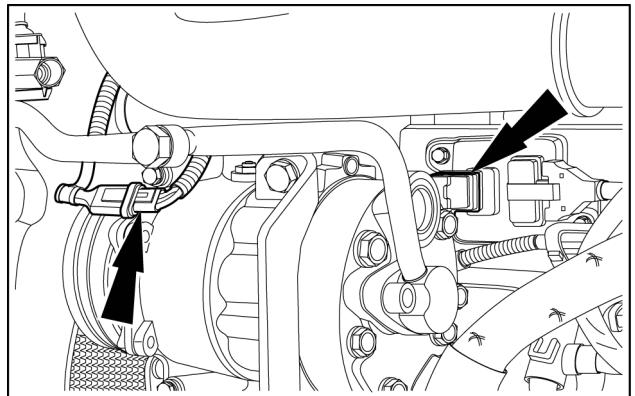

BAIL14TR00963AB 36

37. 1. Detach the wiring harness from the clips.
2. Disconnect the in-line electrical connector.

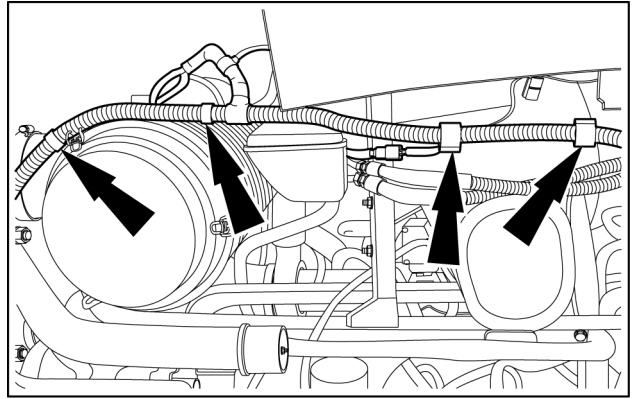

BAIL14TR00964AB 37

38. Disconnect the hood wiring harness in-line electrical connector.

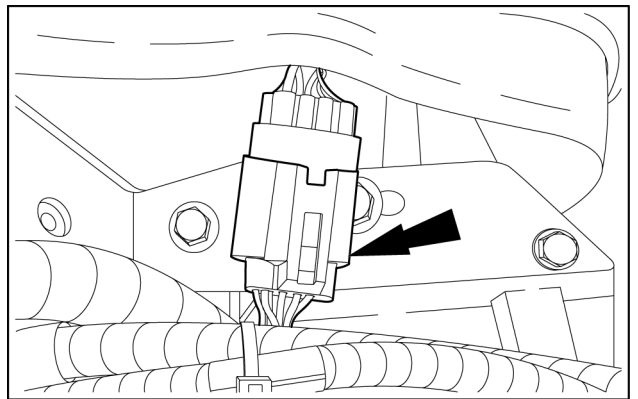

BAIL14TR00903AB 38

Vehicles with standard front axle

39. Remove the front wheel drive shaft guard front retaining bolts.

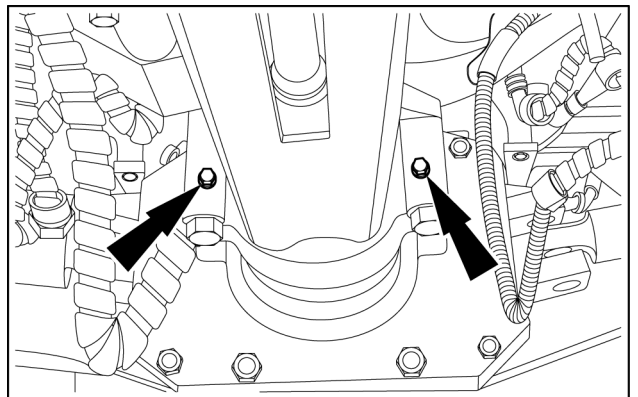

BAIL14TR00955AB 39

40. Remove the front wheel drive shaft guard rear retaining bolts.

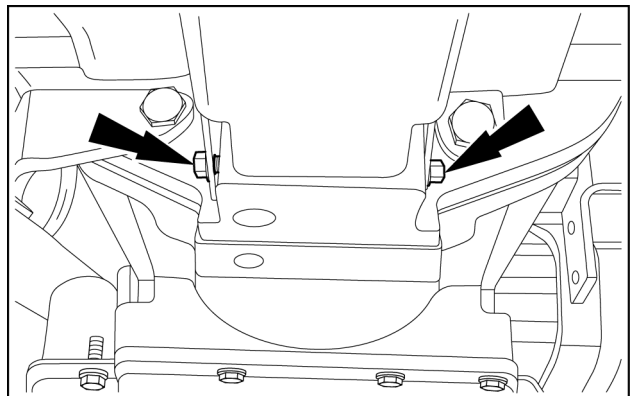

BAIL14TR00956AB 40

41. Remove the front wheel drive shaft guard.

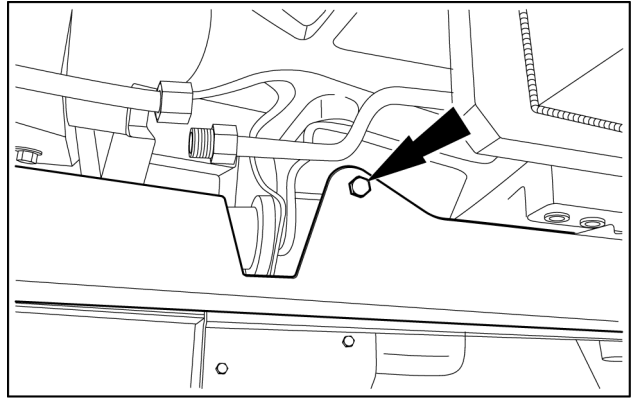

BAIL14TR00965AB 41

42. Disconnect the front wheel drive shaft.

- A. Detach the circlip (1).
- B. Slide the front wheel drive shaft sleeve (2).

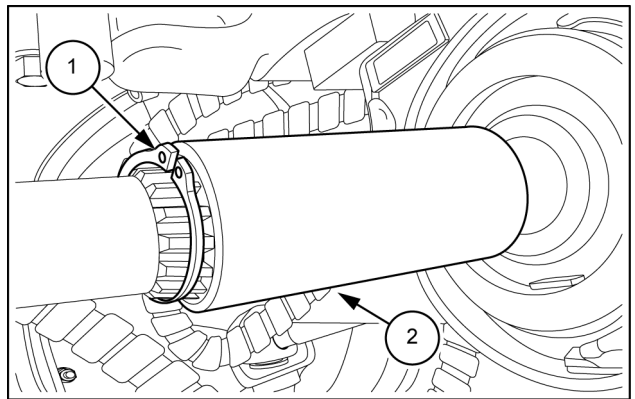

BAIL14TR00966AB 42

43. Remove the front wheel drive shaft.

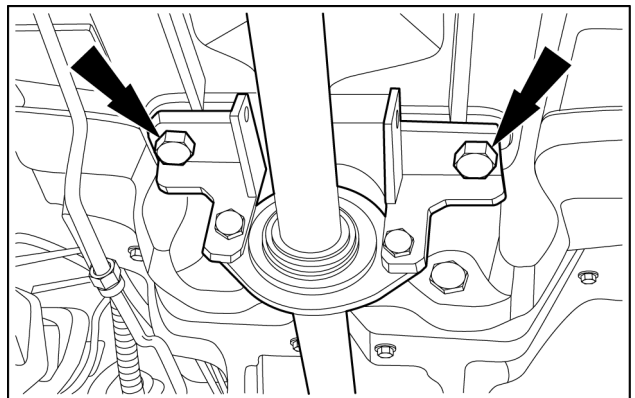

BAIL14TR00967AB 43

Vehicles with suspended front axle

44. Remove the front wheel drive shaft guard.

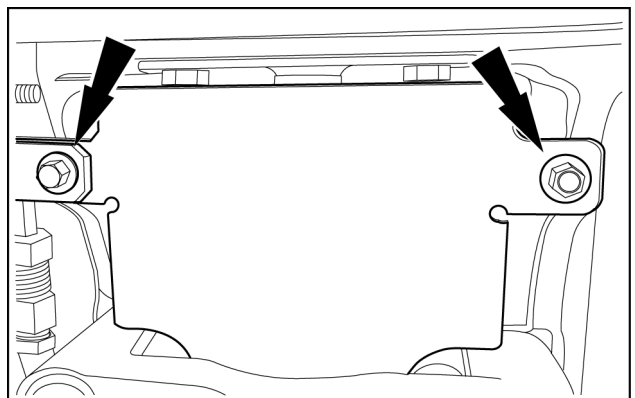

BAIL13TR01694AB 44

45. 1. Remove the circlip (1).
2. Slide the front wheel drive shaft sleeve (2).

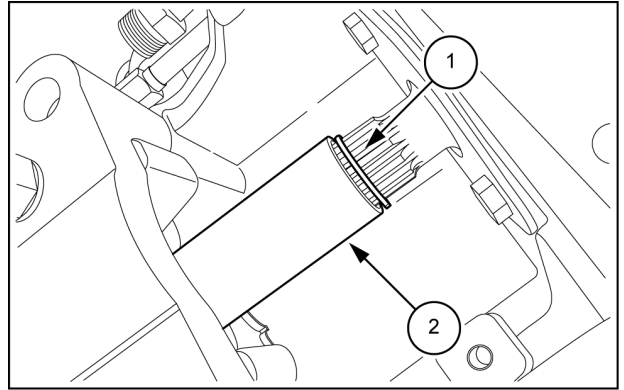

BAIL13TR01695AB 45

46. Remove the oil cooler lines.

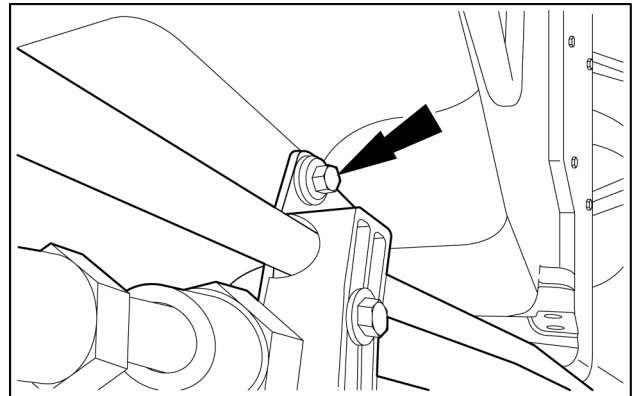

BAIL13TR00747AB 46

47. 1. Using a suitable trolley jack support the front axle suspension arm.
2. Remove the front axle suspension arm retaining bolts.
3. Lower the suspension arm and remove the trolley jack.

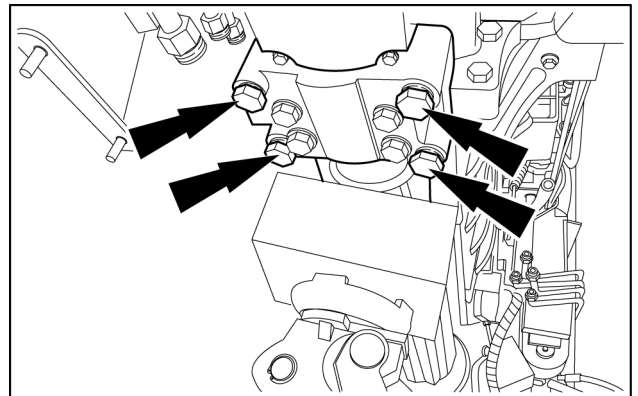

BAIL13TR01693AB 47

All vehicles

48. Remove the engine to transmission lower inner retaining bolts.

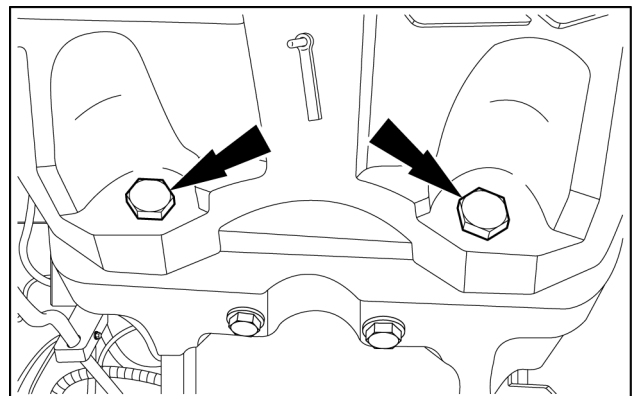

BAIL14TR00968AB 48

49. Remove the engine to transmission lower outer retaining bolts.

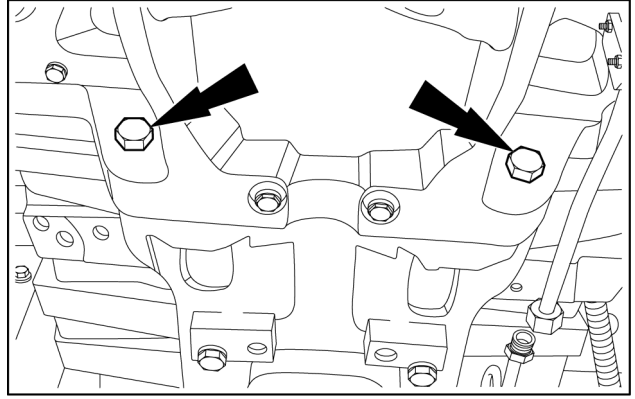

BAIL14TR00969AB 49

50. Position the static part of the tractor splitting stand **380003352** under the transmission and secure to the right-hand side of the transmission.

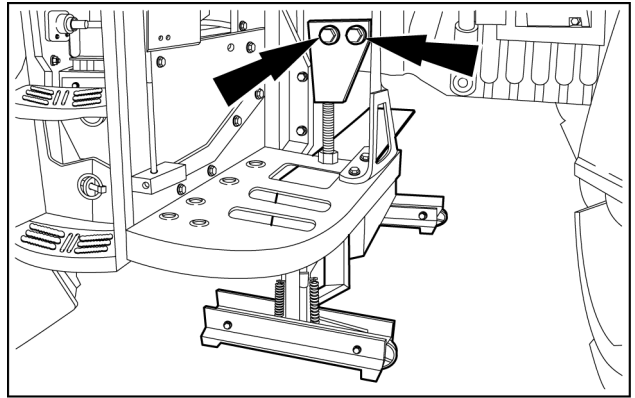

BAIL14TR00982AB 50

51. Secure the static part of the tractor splitting stand **380003352** to the left-hand side of the transmission.

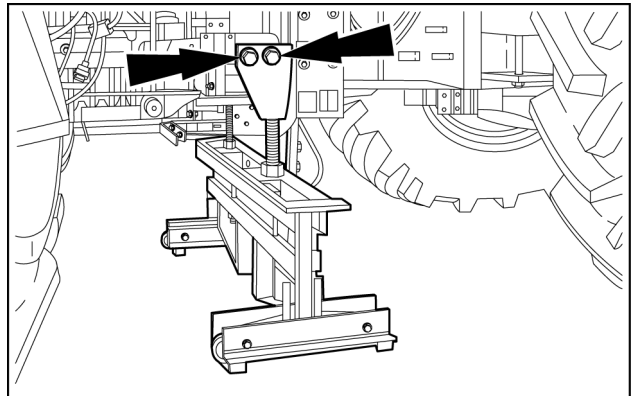

BAIL14TR00983AB 51

52. Install the smaller wheeled part of the tractor splitting stand **380003352** under the engine.

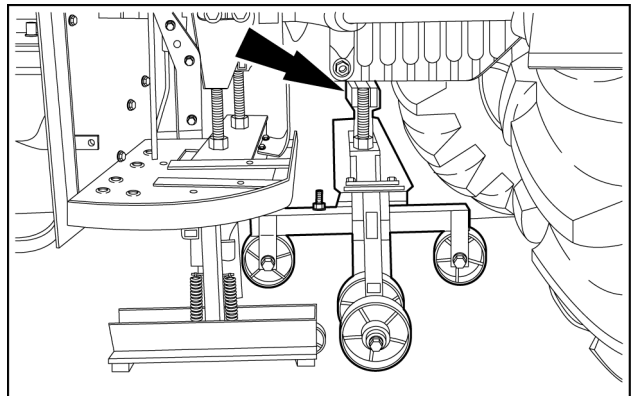

BAIL14TR00984AB 52

53. Install the tractor splitting stand **380003352** alignment bar to the front part of the splitting kit.

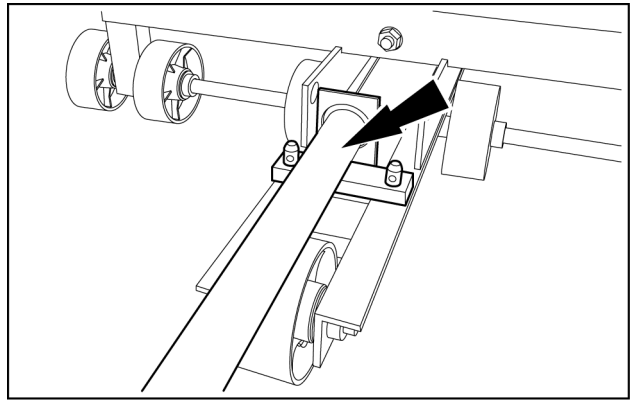

BAIL13TR01696AB 53

54. Install the larger wheeled part of the tractor splitting stand **380003352** to the front frame and support the weight of the tractor with splitting stand.

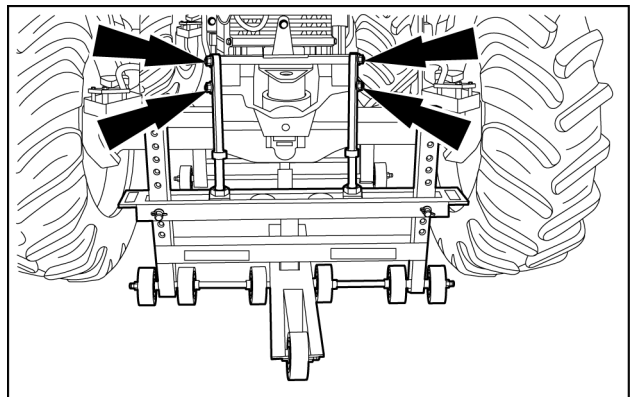

BAIL15TR00014AA 54

55. Tighten the alignment bar bolt.

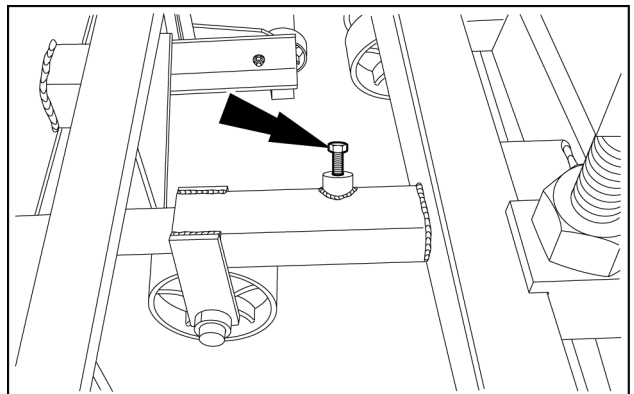

BAIL15TR00015AA 55

56. Remove the engine to transmission upper retaining bolts.

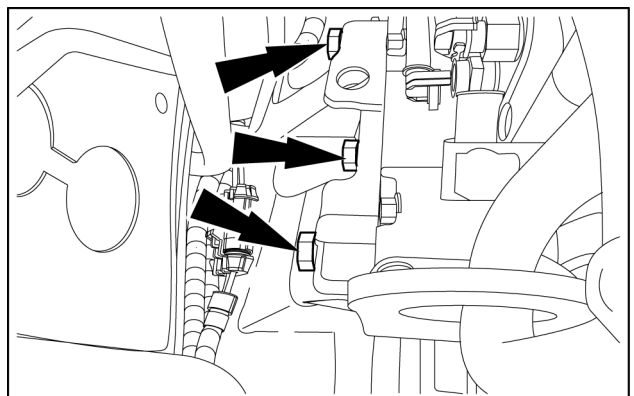

BAIL13TR00798AB 56

57. Remove the engine to transmission right-hand side retaining bolts.

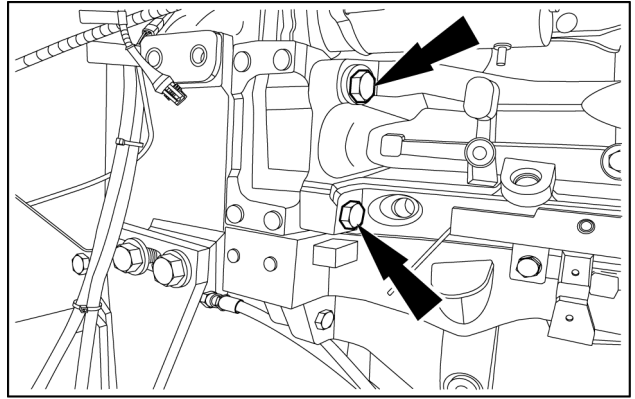

BAIL13TR00797AB 57

58. Remove the engine to transmission left-hand side retaining bolts.

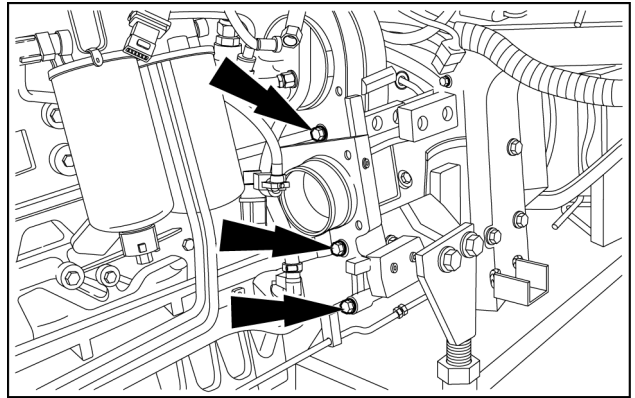

BAIL15TR00016AA 58

59. Roll the front axle and engine assembly away from the transmission.

Engine - Connect

MAXXUM® 115 Multicontroller	NA
MAXXUM® 115	NA
MAXXUM® 125 Multicontroller	NA
MAXXUM® 125	NA
MAXXUM® 135 Multicontroller	NA
MAXXUM® 135	NA
MAXXUM® 145 Multicontroller	NA
MAXXUM® 145	NA
MAXXUM® 150 Multicontroller	NA
MAXXUM® 150	NA

⚠ WARNING

Heavy objects!

Lift and handle all heavy components using lifting equipment with adequate capacity. Always support units or parts with suitable slings or hooks. Make sure the work area is clear of all bystanders.

Failure to comply could result in death or serious injury.

W0398A

⚠ WARNING

Avoid injury!

Handle all parts carefully. Do not place your hands or fingers between parts. Use Personal Protective Equipment (PPE) as indicated in this manual, including protective goggles, gloves, and safety footwear.

Failure to comply could result in death or serious injury.

W0208A

All vehicles

1. Thoroughly clean the engine to transmission mating surfaces.
2. Apply a bead of liquid gasket of approximately **2 mm** diameter.
3. Align and install the front axle and engine assembly to the transmission.
4.
 1. Install the engine to transmission left-hand side retaining bolts.
 2. Torque to **285-315 Nm (210-232 lb ft)**.

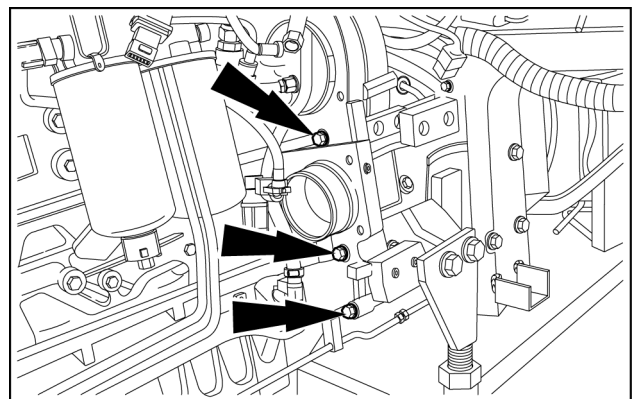

BAIL15TR00016AA 1

5. 1. Install the engine to transmission right-hand side retaining bolts.
2. Torque to **285-315 Nm (210-232 lb ft)**.

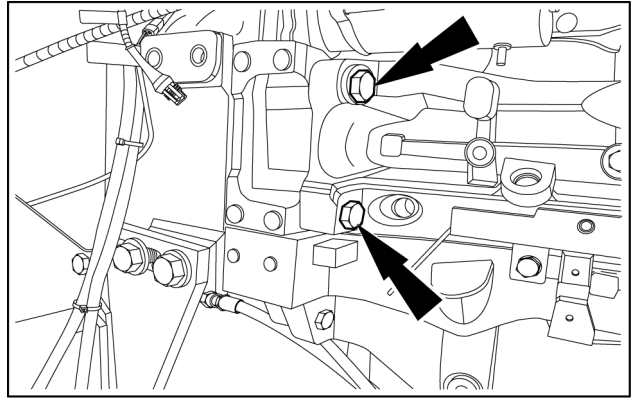

BAIL13TR00797AB 2

6. 1. Install the engine to transmission upper retaining bolts.
2. Torque to **285-315 Nm (210-232 lb ft)**.

NOTE: *The center bolt is unique in length.*

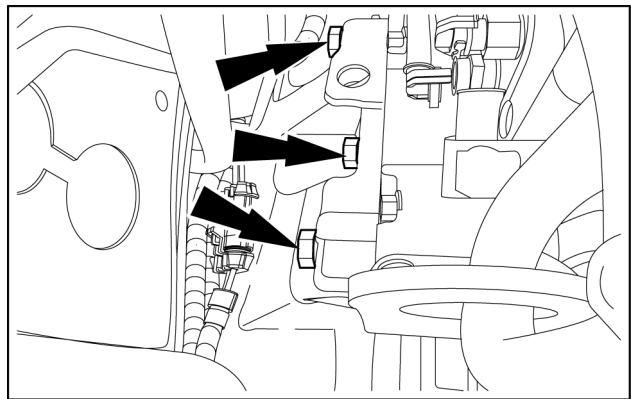

BAIL13TR00798AB 3

7. Loosen the alignment bar bolt.

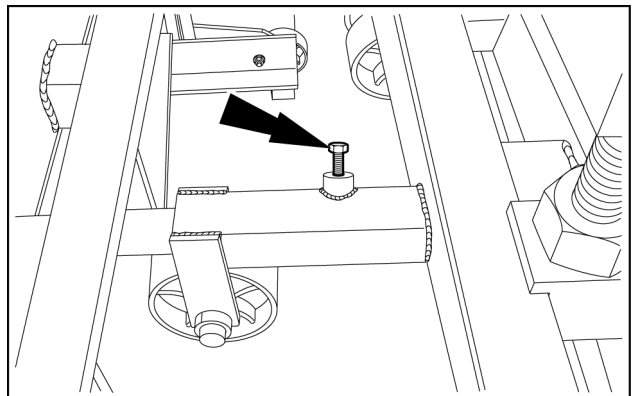

BAIL15TR00015AA 4

8. Remove the larger wheeled part of the tractor splitting stand **380003352** from the front frame.

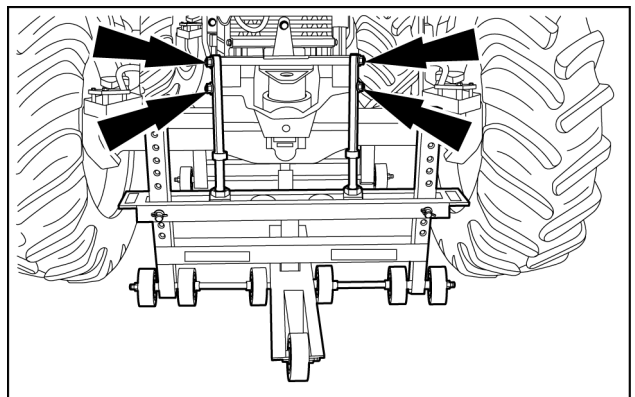

BAIL15TR00014AA 5

9. Remove the tractor splitting stand **380003352** alignment bar from the front part of the splitting kit.

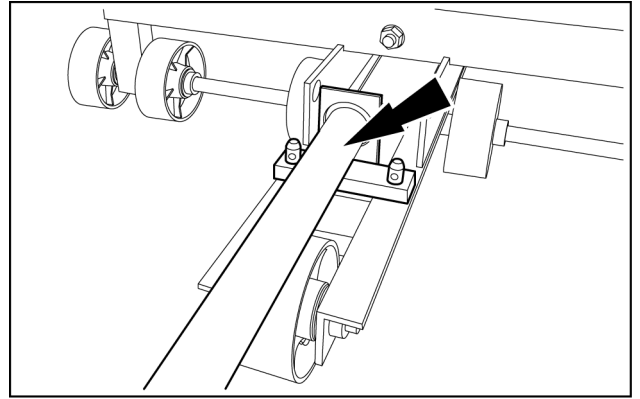

BAIL13TR01696AB 6

10. Remove the smaller wheeled part of the tractor splitting stand **380003352** from under the engine.

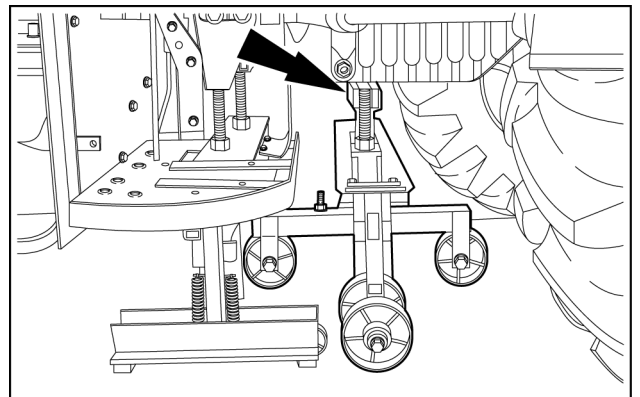

BAIL14TR00984AB 7

11. Remove the static part of the tractor splitting stand **380003352** from the left-hand side of the transmission.

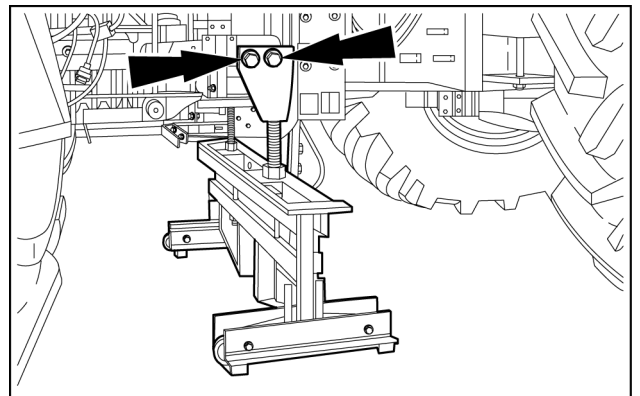

BAIL14TR00983AB 8

12. Remove the static part of the tractor splitting stand **380003352** from the right-hand side of the transmission.

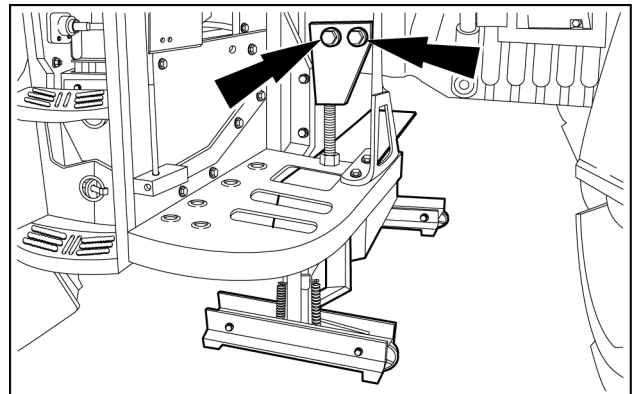

BAIL14TR00982AB 9

13. Remove the static part of the tractor splitting stand **380003352** from under the transmission.



Suggest:

If the above button click is invalid.

Please download this document

first, and then click the above link

to download the complete manual.

Thank you so much for reading

14. 1. Install the engine to transmission lower outer retaining bolts.
2. Torque to **285-315 Nm (210-232 lb ft)**.

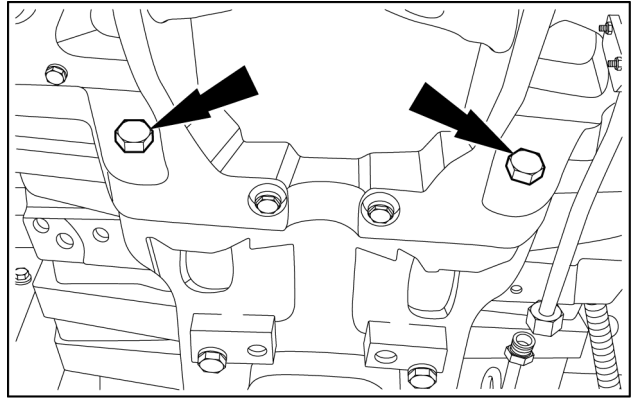

BAIL14TR00969AB 10

15. 1. Install the engine to transmission lower inner retaining bolts.
2. Torque to **285-315 Nm (210-232 lb ft)**.

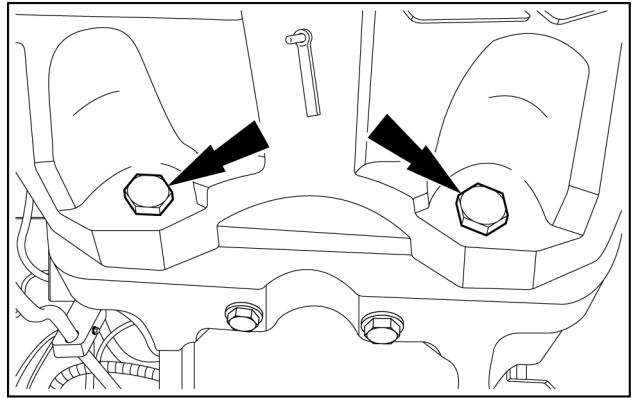

BAIL14TR00968AB 11

Vehicles with suspended front axle

16. 1. Using a suitable trolley jack raise and support the front axle suspension arm.
2. Install the front axle suspension arm retaining bolts.

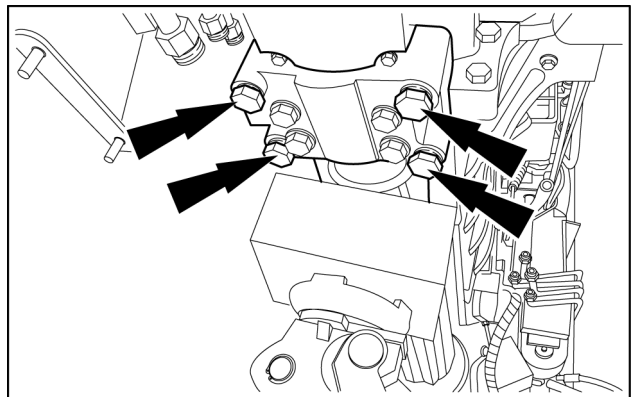

BAIL13TR01693AB 12

17. Install the oil cooler lines.

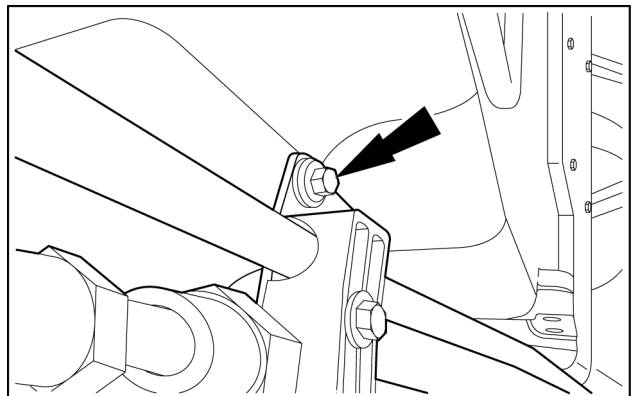

BAIL13TR00747AB 13

<https://www.ebooklibonline.com>

Hello dear friend!

Thank you very much for reading.

Enter the link into your browser.

The full manual is available for immediate download.

<https://www.ebooklibonline.com>