



## SERVICE MANUAL

**Magnum™ 250 PST TIER 4B [ZGRF05001 - ], Magnum™ 280 PST TIER 4B [ZGRF05001 - ], Magnum™ 310 PST TIER 4B [ZGRF05001 - ], Magnum™ 310 Rowtrac™ PST TIER 4B [ZGRF05001 - ], Magnum™ 340 PST TIER 4B [ZGRF05001 - ], Magnum™ 340 Rowtrac™ PST TIER 4B [ZGRF05001 - ]**

## Link Product / Engine

Product	Market Product	Engine
Magnum™ 250 PST TIER 4B [ZGRF05001 - ]	Australia New Zealand	F2CFE613G*B002
Magnum™ 250 PST TIER 4B [ZGRF05001 - ]	North America	F2CFE613G*B002
Magnum™ 280 PST TIER 4B [ZGRF05001 - ]	Australia New Zealand	F2CFE614G*B002
Magnum™ 280 PST TIER 4B [ZGRF05001 - ]	North America	F2CFE614G*B002
Magnum™ 310 PST TIER 4B [ZGRF05001 - ]	Australia New Zealand	F2CFE614D*B002
Magnum™ 310 PST TIER 4B [ZGRF05001 - ]	North America	F2CFE614D*B002
Magnum™ 340 PST TIER 4B [ZGRF05001 - ]	North America	F2CFE614C*B002
Magnum™ 340 PST TIER 4B [ZGRF05001 - ]	Australia New Zealand	F2CFE614C*B002
Magnum™ 310 Rowtrac™ PST TIER 4B [ZGRF05001 - ]	Australia New Zealand	F2CFE614D*B002
Magnum™ 310 Rowtrac™ PST TIER 4B [ZGRF05001 - ]	North America	F2CFE614D*B002
Magnum™ 340 Rowtrac™ PST TIER 4B [ZGRF05001 - ]	Australia New Zealand	F2CFE614C*B002
Magnum™ 340 Rowtrac™ PST TIER 4B [ZGRF05001 - ]	North America	F2CFE614C*B002

# Contents

---

## INTRODUCTION

<b>Engine</b> .....	<b>10</b>
[10.001] Engine and crankcase .....	10.1
[10.101] Cylinder heads .....	10.2
[10.202] Air cleaners and lines .....	10.3
[10.206] Fuel filters .....	10.4
[10.216] Fuel tanks .....	10.5
[10.218] Fuel injection system.....	10.6
[10.304] Engine lubrication system.....	10.7
[10.310] Aftercooler.....	10.8
[10.400] Engine cooling system .....	10.9
[10.414] Fan and drive .....	10.10
[10.500] Selective Catalytic Reduction (SCR) exhaust treatment.....	10.11
<b>Power coupling</b> .....	<b>19</b>
[19.100] Drive shaft.....	19.1
[19.110] Flywheel damper .....	19.2
[19.120] Drive shaft shield assembly .....	19.3
<b>Transmission</b> .....	<b>21</b>
[21.105] Powershift transmission hydraulic components .....	21.1
[21.113] Powershift transmission .....	21.2
[21.135] Powershift transmission external controls.....	21.3
[21.155] Powershift transmission internal components.....	21.4
[21.200] Dropbox .....	21.5
[21.900] Hydraulic pump drive.....	21.6
<b>Four-Wheel Drive (4WD) system</b> .....	<b>23</b>
[23.202] Electro-hydraulic control .....	23.1

**<https://www.ebooklibonline.com>**

Hello dear friend!

Thank you very much for reading.

Enter the link into your browser.

The full manual is available for immediate download.

**<https://www.ebooklibonline.com>**

[23.314] Drive shaft.....	23.2
<b>Front axle system .....</b>	<b>25</b>
[25.100] Powered front axle .....	25.1
[25.102] Front bevel gear set and differential .....	25.2
[25.108] Final drive hub, steering knuckles, and shafts .....	25.3
[25.122] Axle suspension control.....	25.4
<b>Rear axle system.....</b>	<b>27</b>
[27.100] Powered rear axle.....	27.1
[27.106] Rear bevel gear set and differential.....	27.2
[27.120] Planetary and final drives .....	27.3
[27.610] Rear axle track yoke assembly .....	27.4
<b>Power Take-Off (PTO).....</b>	<b>31</b>
[31.104] Rear electro-hydraulic control.....	31.1
[31.110] One-speed rear Power Take-Off (PTO) .....	31.2
[31.114] Two-speed rear Power Take-Off (PTO) .....	31.3
[31.146] Front Power Take-Off (PTO) .....	31.4
<b>Brakes and controls .....</b>	<b>33</b>
[33.110] Parking brake or parking lock .....	33.1
[33.202] Hydraulic service brakes .....	33.2
[33.220] Trailer brake hydraulic control.....	33.3
[33.224] Trailer brake pneumatic control .....	33.4
<b>Hydraulic systems.....</b>	<b>35</b>
[35.000] Hydraulic systems.....	35.1
[35.102] Pump control valves.....	35.2
[35.106] Variable displacement pump .....	35.3
[35.114] Three-point hitch control valve .....	35.4
[35.124] Three-point hitch hydraulic adjustment .....	35.5
[35.204] Remote control valves .....	35.6

[35.300] Reservoir, cooler, and filters.....	35.7
[35.304] Combination pump units .....	35.8
<b>Hitches, drawbars, and implement couplings.....</b>	<b>37</b>
[37.110] Rear three-point hitch .....	37.1
[37.162] Front hitch .....	37.2
<b>Frames and ballasting .....</b>	<b>39</b>
[39.100] Frame .....	39.1
<b>Steering.....</b>	<b>41</b>
[41.101] Steering control .....	41.1
[41.200] Hydraulic control components.....	41.2
[41.206] Pump .....	41.3
[41.432] Autoguidance steering .....	41.4
<b>Wheels .....</b>	<b>44</b>
[44.520] Rear wheels .....	44.1
<b>Tracks and track suspension .....</b>	<b>48</b>
[48.100] Tracks .....	48.1
[48.130] Track frame and driving wheels.....	48.2
[48.134] Track tension units .....	48.3
[48.138] Track rollers .....	48.4
<b>Cab climate control .....</b>	<b>50</b>
[50.100] Heating .....	50.1
[50.200] Air conditioning.....	50.2
[50.300] Cab pressurizing system .....	50.3
<b>Electrical systems .....</b>	<b>55</b>
[55.000] Electrical system .....	55.1
[55.010] Fuel injection system.....	55.2
[55.012] Engine cooling system .....	55.3

[55.013] Engine oil system .....	55.4
[55.014] Engine intake and exhaust system.....	55.5
[55.015] Engine control system.....	55.6
[55.024] Transmission control system .....	55.7
[55.045] Front axle control system .....	55.8
[55.046] Rear axle control system.....	55.9
[55.047] Steering control system .....	55.10
[55.050] Heating, Ventilation, and Air-Conditioning (HVAC) control system.....	55.11
[55.051] Cab Heating, Ventilation, and Air-Conditioning (HVAC) controls.....	55.12
[55.100] Harnesses and connectors.....	55.13
[55.130] Rear three-point hitch electronic control system .....	55.14
[55.201] Engine starting system.....	55.15
[55.301] Alternator.....	55.16
[55.302] Battery.....	55.17
[55.408] Warning indicators, alarms, and instruments .....	55.18
[55.510] Cab or platform harnesses and connectors.....	55.19
[55.512] Cab controls.....	55.20
[55.513] Cab transmission controls.....	55.21
[55.518] Wiper and washer system.....	55.22
[55.640] Electronic modules .....	55.23
[55.988] Selective Catalytic Reduction (SCR) electrical system .....	55.24
[55.DTC] FAULT CODES.....	55.25

**Platform, cab, bodywork, and decals .....** 90

[90.100] Engine hood and panels .....	90.1
[90.102] Engine shields, hood latches, and trims .....	90.2
[90.124] Pneumatically-adjusted operator seat.....	90.3
[90.150] Cab.....	90.4
[90.151] Cab interior.....	90.5



# INTRODUCTION

---

## **Foreword - Important notice regarding equipment servicing**

All repair and maintenance work listed in this manual must be carried out only by qualified dealership personnel, strictly complying with the instructions given, and using, whenever possible, the special tools.

Anyone who performs repair and maintenance operations without complying with the procedures provided herein shall be responsible for any subsequent damages.

The manufacturer and all the organizations of its distribution chain, including - without limitation - national, regional, or local dealers, reject any responsibility for damages caused by parts and/or components not approved by the manufacturer, including those used for the servicing or repair of the product manufactured or marketed by the manufacturer. In any case, no warranty is given or attributed on the product manufactured or marketed by the manufacturer in case of damages caused by parts and/or components not approved by the manufacturer.

The manufacturer reserves the right to make improvements in design and changes in specifications at any time without notice and without incurring any obligation to install them on units previously sold. Specifications, descriptions, and illustrative material herein are as accurate as known at time of publication but are subject to change without notice.

In case of questions, refer to your CASE IH Sales and Service Networks.

## Safety rules

### Personal safety



This is the safety alert symbol. It is used to alert you to potential personal injury hazards. Obey all safety messages that follow this symbol to avoid possible death or injury.

Throughout this manual you will find the signal words DANGER, WARNING, and CAUTION followed by special instructions. These precautions are intended for the personal safety of you and those working with you.

Read and understand all the safety messages in this manual before you operate or service the machine.

 DANGER indicates a hazardous situation that, if not avoided, will result in death or serious injury.

 WARNING indicates a hazardous situation that, if not avoided, could result in death or serious injury.

 CAUTION indicates a hazardous situation that, if not avoided, could result in minor or moderate injury.

**FAILURE TO FOLLOW DANGER, WARNING, AND CAUTION MESSAGES COULD RESULT IN DEATH OR SERIOUS INJURY.**

### Machine safety

**NOTICE:** Notice indicates a situation that, if not avoided, could result in machine or property damage.

Throughout this manual you will find the signal word Notice followed by special instructions to prevent machine or property damage. The word Notice is used to address practices not related to personal safety.

### Information

**NOTE:** Note indicates additional information that clarifies steps, procedures, or other information in this manual.

Throughout this manual you will find the word Note followed by additional information about a step, procedure, or other information in the manual. The word Note is not intended to address personal safety or property damage.

---

## Safety rules - General maintenance safety

### General maintenance safety

Keep the area used for servicing the machine clean and dry. Clean up spilled fluids.

Service the machine on a firm, level surface.

Install guards and shields after you service the machine.

Close all access doors and install all panels after servicing the machine.

Do not attempt to clean, lubricate, clear obstructions, or make adjustments to the machine while it is in motion or while the engine is running.

Always make sure that working area is clear of tools, parts, other persons and pets before you start operating the machine.

Unsupported hydraulic cylinders can lose pressure and drop the equipment, causing a crushing hazard. Do not leave equipment in a raised position while parked or during service, unless the equipment is securely supported.

Jack or lift the machine only at jack or lift points indicated in this manual.

Incorrect towing procedures can cause accidents. When you tow a disabled machine follow the procedure in this manual. Use only rigid tow bars.

Stop the engine, remove the key, and relieve pressure before you connect or disconnect fluid lines.

Stop the engine and remove the key before you connect or disconnect electrical connections.

Scalding can result from incorrect removal of coolant caps. Cooling systems operate under pressure. Hot coolant can spray out if you remove a cap while the system is hot. Allow the system to cool before you remove the cap. When you remove the cap, turn it slowly to allow pressure to escape before you completely remove the cap.

Replace damaged or worn tubes, hoses, electrical wiring, etc.

The engine, transmission, exhaust components, and hydraulic lines may become hot during operation. Take care when you service such components. Allow surfaces to cool before you handle or disconnect hot components. Wear protective equipment when appropriate.

When welding, follow the instructions in the manual. Always disconnect the battery before you weld on the machine. Always wash your hands after you handle battery components.

## Product identification - Machine orientation

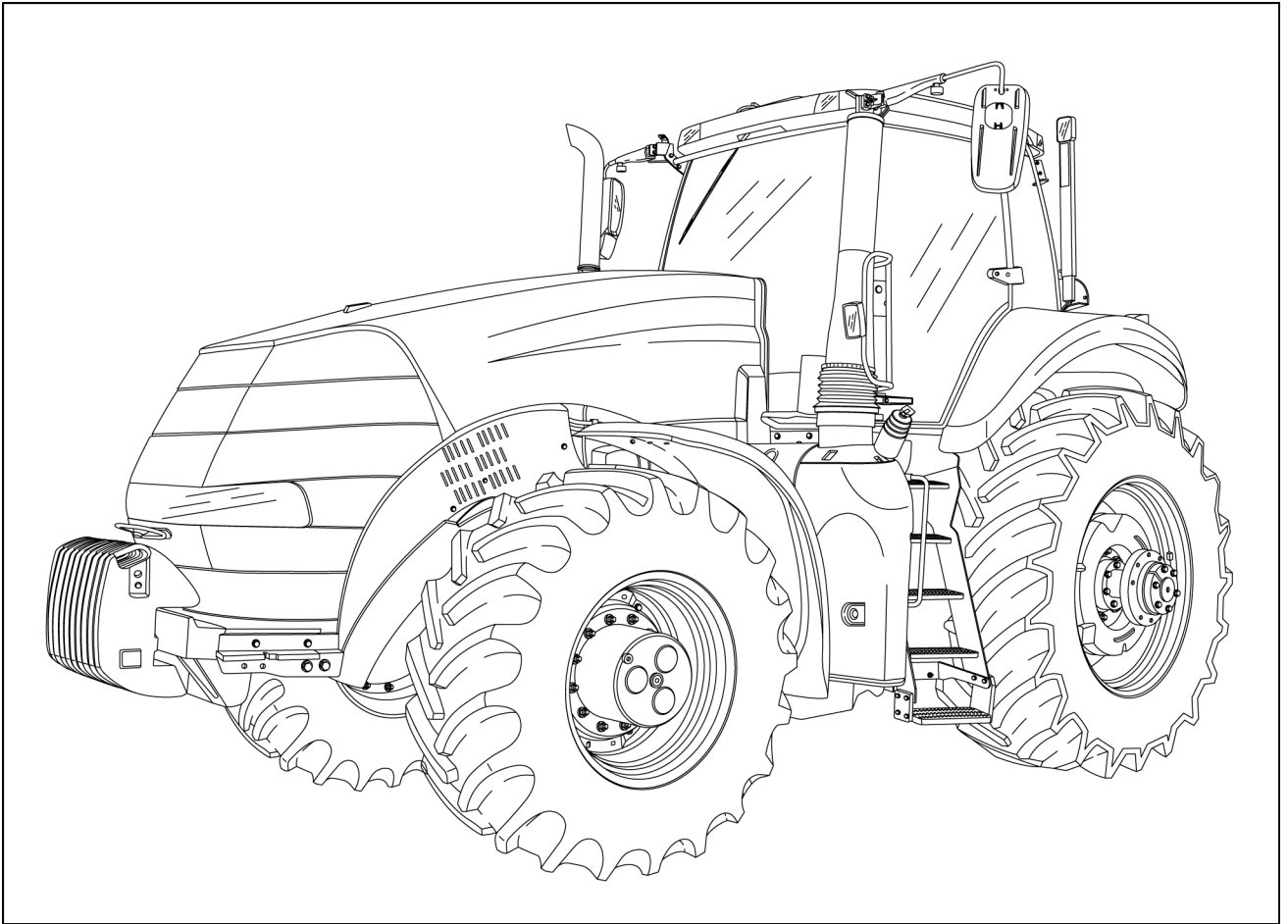

RAIL14TR02053GA 1

The right hand and left hand side of the tractor used in this manual are the same as your right hand and left hand when sitting in the tractor seat looking forward.



## **SERVICE MANUAL**

### **Engine**

**Magnum™ 250 PST TIER 4B [ZGRF05001 - ], Magnum™ 280 PST TIER 4B [ZGRF05001 - ], Magnum™ 310 PST TIER 4B [ZGRF05001 - ], Magnum™ 310 Rowtrac™ PST TIER 4B [ZGRF05001 - ], Magnum™ 340 PST TIER 4B [ZGRF05001 - ], Magnum™ 340 Rowtrac™ PST TIER 4B [ZGRF05001 - ]**

---

## Engine - General information - Dynamometer testing guidelines

One of the main services which a dealership provides is verifying tractor engine and Power Take-Off (PTO) performance with a dynamometer. As agricultural engine technology has become more sophisticated, dynamometer testing of these machines must become more sophisticated and consistent to deal with the advancements.

During manufacturing, the engine for each machine is run on an engine dynamometer to ensure that the power produced from the engine is within the specified parameters. These tests are performed under strictly controlled conditions which can be difficult to replicate in a dealership environment.

For example, the following conditions in detail are recorded when establishing the power output of an engine:

Humidity	Fuel temperature
Ambient air temperature	Fuel specification
Atmospheric pressure (barometer)	Fuel density
Altitude	Dynamometer accuracy

Any or all of these factors can affect the power output of an engine, so some tolerances must be applied to power measurements from dynamometer testing at the dealership. Weather, air and fuel conditions affect tractor performance.

As a general rule, remember:

- As air temperature DECREASES, power INCREASES.
- As atmospheric pressure (barometer) DECREASES, power DECREASES.
- As altitude INCREASES, the power DECREASES about **2%** for every **300 m (1500 ft)** above **1500 m (5000 ft)** for turbo-charged engines.
- As fuel density INCREASES, power INCREASES.
- As fuel temperature INCREASES, power DECREASES.

A standard test procedure must be followed so that results from a dynamometer test are consistent and accurate. These results can then be recorded and used for future comparison.

**NOTE:** *The power/torque readings from a dynamometer test are the rate speed, full load, PTO power maximum torque achieved by the tested tractor. These readings could be lower than the PTO power advertised for the tractor under test, depending on tractor/engine equipment (parasitics) and the ambient environment test conditions. Also note, maximum PTO power may be observed at an engine RPM less than the advertised rated engine RPM. For example, while the rated engine RPM may be **2000 RPM**, maximum PTO horsepower may be observed at **1800 RPM**. This is typically defined as peak power or power bulge.*

### Perform these actions if a dyno test shows low power

1. Check the fuel injection system for faults or a derate condition. Perform the corresponding fault code resolution and rectify the problem.
2. Run the test a second time to collect comparative data. You must record the ambient air temperature, fuel temperature, and water temperature.
3. Check all supply lines for restrictions, air ingress and cleanliness.
4. Check the air intake system and the filter(s) condition and cleanliness.
5. Run the test for a third time.

If the power is still not acceptable, escalate the concern with ASIST. Supply the following information:

- The completed dynamometer testing worksheet. See **Engine - General information - Dyno test worksheet (10.001)**
- All other collected documentation such as dynamometer test results, dynamometer calibration, fault codes, service actions taken, etc.

## Engine - Remove

Prior operation:

Battery - Disconnect (55.302)

Prior operation:

Hood - Remove (90.100)

Prior operation:

Side shield - Remove (90.102)

Prior operation:

Air conditioning - Recover (50.200)

Prior operation:

Engine cooling system - Emptying (10.400)

Prior operation:

Engine cooling system - Remove (10.400)

Prior operation:

Diesel Oxidation Catalyst (DOC) - Remove (10.500)

**NOTE:** Clean all fittings before disconnecting.

**NOTE:** Cap or plug all lines and ports when disconnecting hydraulic components.

1. Disconnect the humidity sensor (1) and the air restriction sensor (2). Disengage the hose clamp (3) and disconnect the hose from the air intake tube.

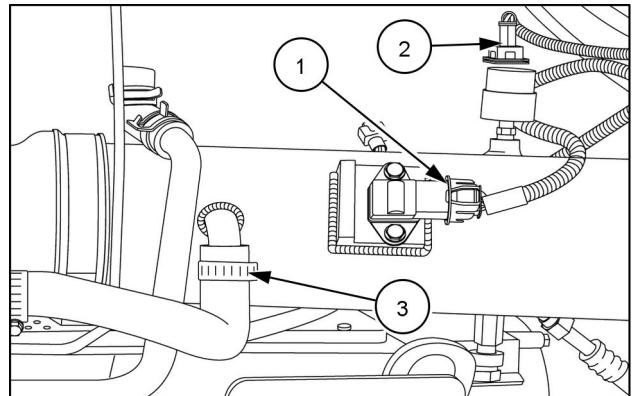

RAIL13TR04202AA 1

2. Disconnect the clamps (1) from each end of the air intake tube and remove the tube.

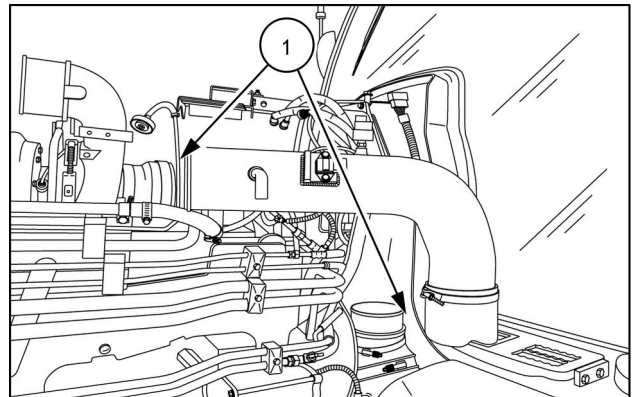

RAIL13TR04211AA 2

3. Cut the wire tie (1) securing the harness to the hood support (2).

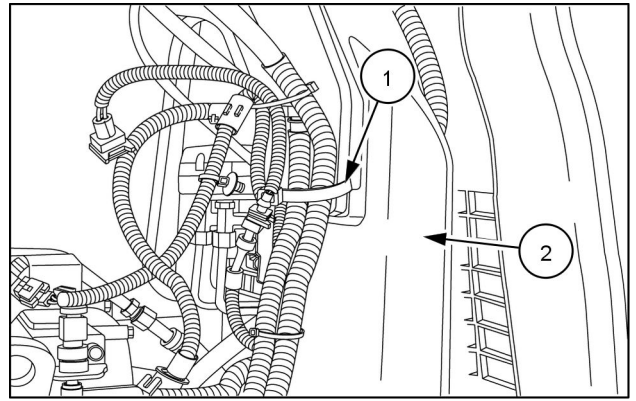

RAIL13TR04204AA 3

4. Disconnect the starter cables (1) and the auxiliary wire (2).

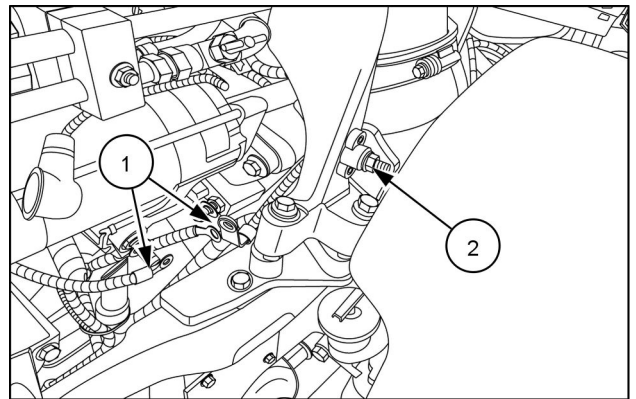

RAIL13TR04209AA 4

5. Remove the three bolts (1) securing the hood support to the frame.

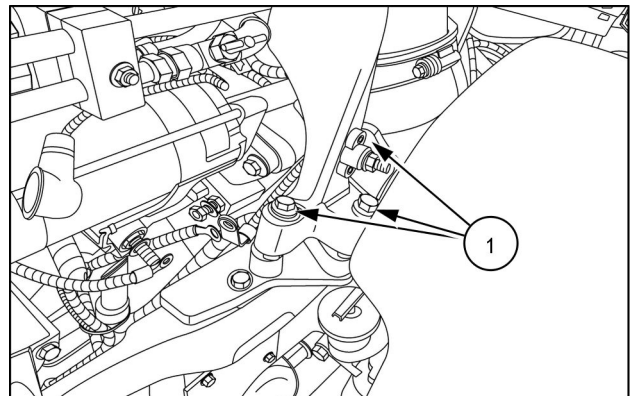

RAIL13TR04209AA 5

6. Remove the hood support.

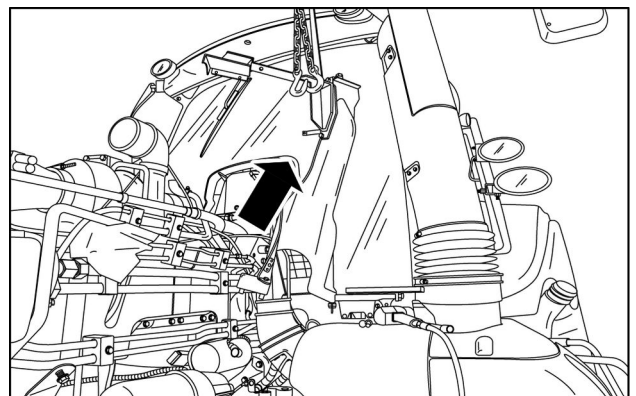

RAIL13TR04212AA 6

7. Disconnect the high pressure A/C hose (1) and the coolant lines (2). Cap or plug all fittings and lines.

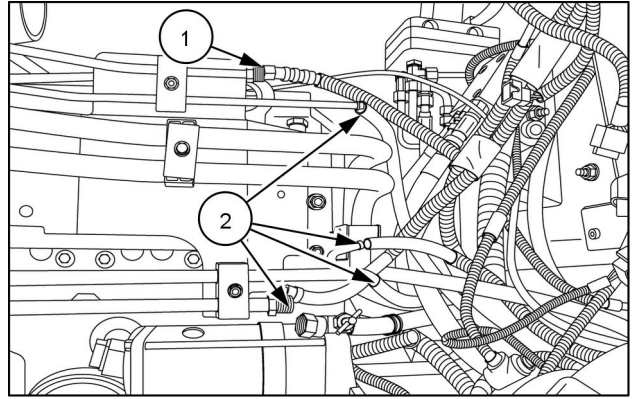

RAIL13TR04230AA 7

8. Remove the two bolts (1) from the rear engine mount plate.

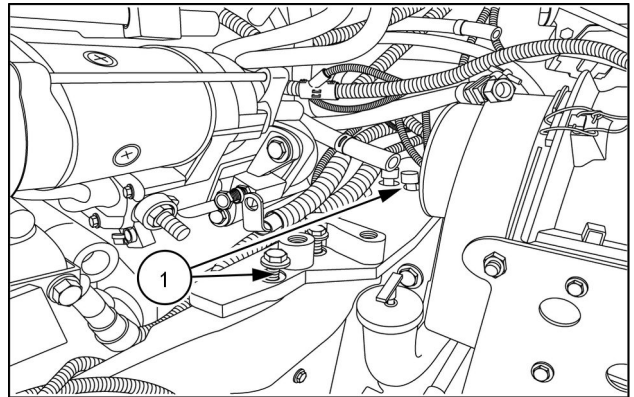

RAIL13TR04243AA 8

9. Remove the engine mount cover plate.

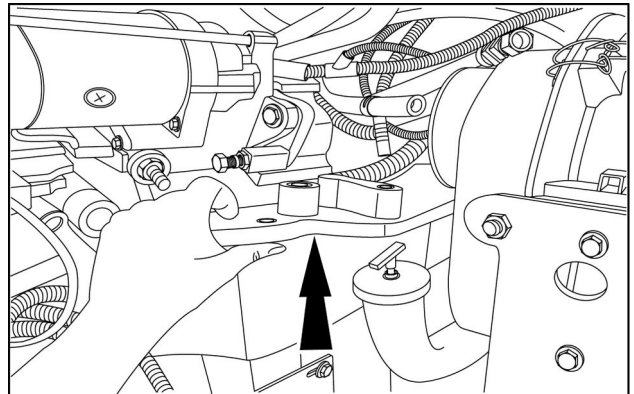

RAIL13TR04244AA 9

10. Disconnect the front suspended axle electrical connectors (1) if equipped.

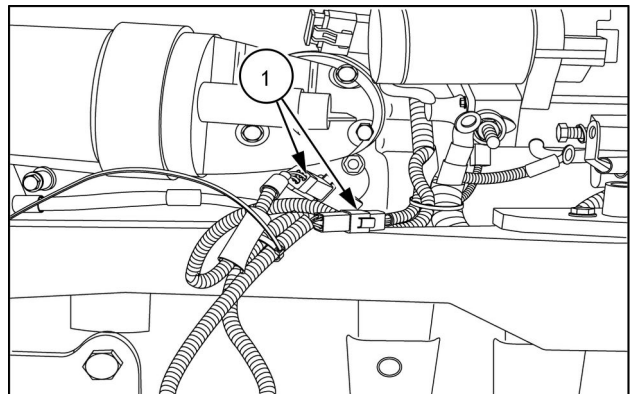

RAIL13TR04237AA 10

11. On the rear of the engine, remove the oil cooler tube clamp (1). Move the oil cooler lines to the side.

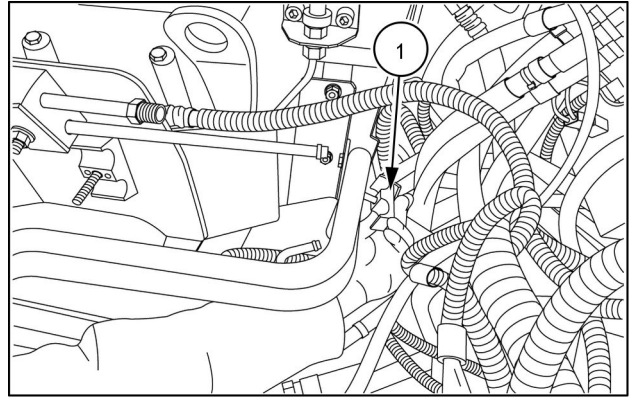

RAIL13TR04236AA 11

12. Disconnect the low pressure A/C line (1). Cap or plug all fittings and hoses.

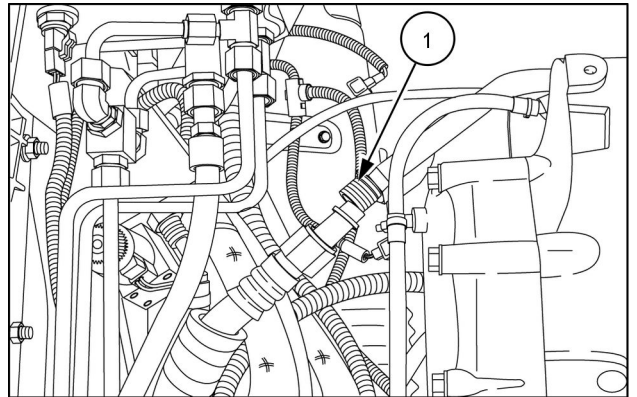

RAIL13TR04228AA 12

13. Disengage the hose clamp and disconnect the engine controller oil line (1).

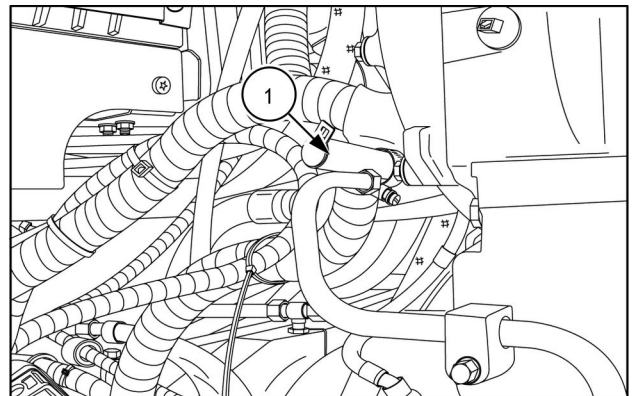

RAIL13TR04227AA 13

14. Remove the three mounting bolts (1) securing the fuse panel bracket.

**NOTE:** Cut any wire ties securing the harness.

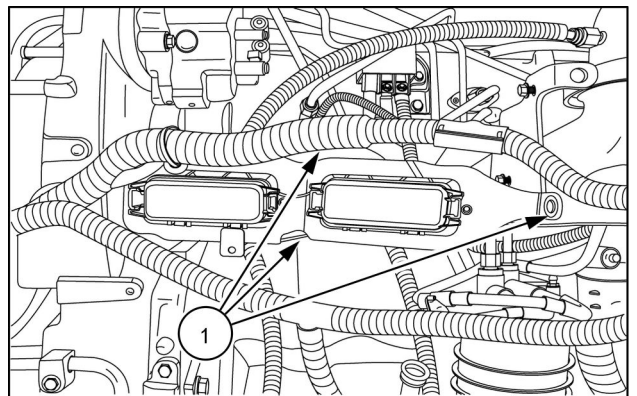

RAIL13TR04216AA 14

15. Remove the fuse panel.

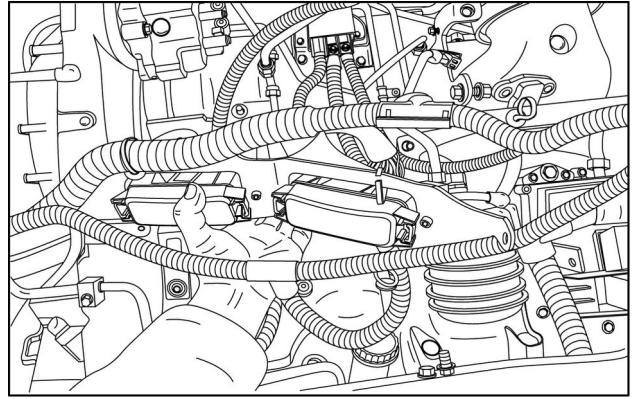

RAIL13TR04214AA 15

16. Disconnect the harness connector (1) for the engine grid heater and the power supply cable (2).

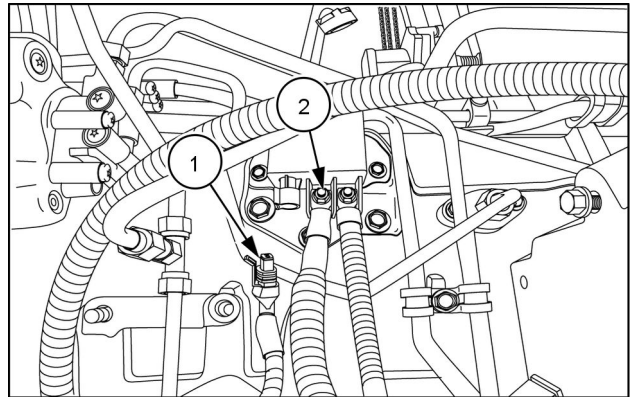

RAIL13TR04219AA 16

17. Disconnect the vent hose (1) from the intake manifold.

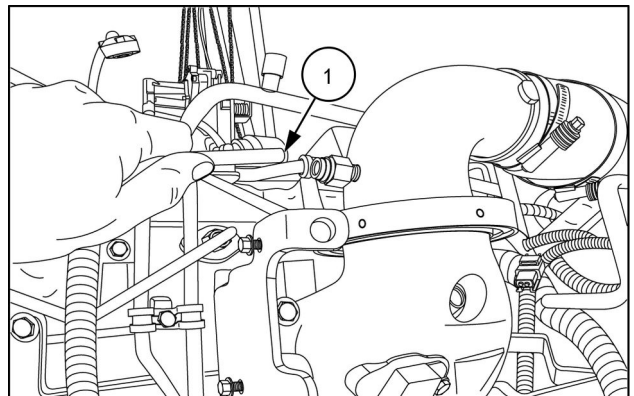

RAIL13TR04218AA 17

18. Disconnect the harness connector (1) for the fan drive.

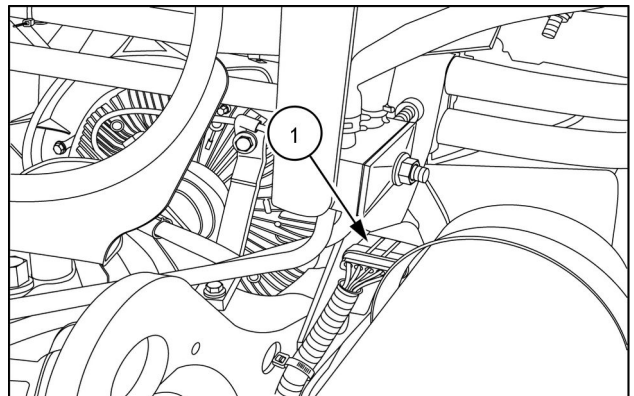

RAIL13TR04220AA 18

19. Remove the A/C compressor mounting bolt (1) and disconnect the ground wire (2).

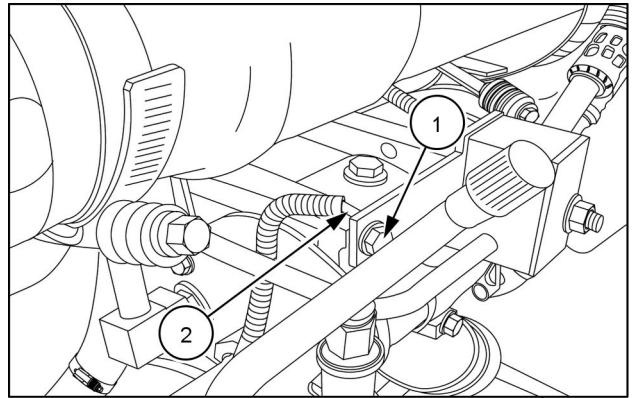

RAIL13TR04224AA 19

20. Disconnect the harness connector (1) to the A/C pressure switch.

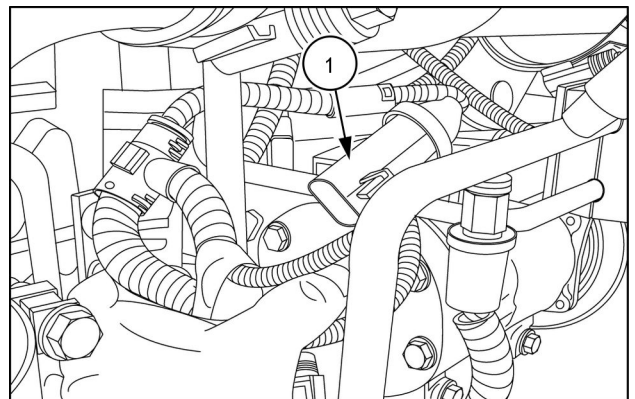

RAIL13TR04223AA 20

21. Disconnect the alternator excite wire connector (1) and the CAN bus connector (2).

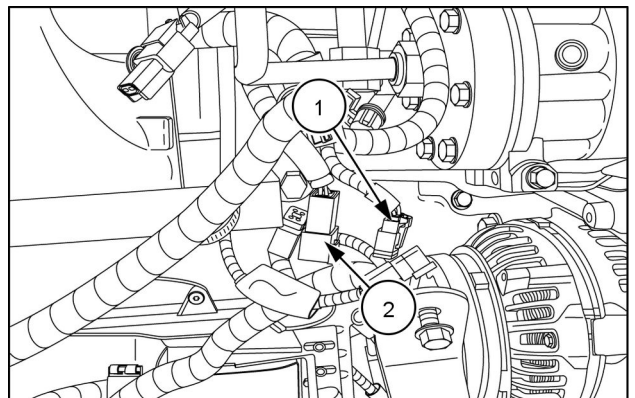

RAIL13TR04221AA 21

22. Remove the nut and disengage the alternator output cable (2).

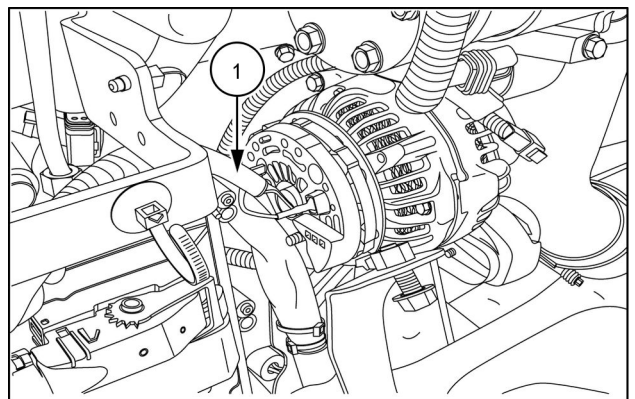

RAIL13TR04231AA 22

23. Disconnect the engine controller connector (1).

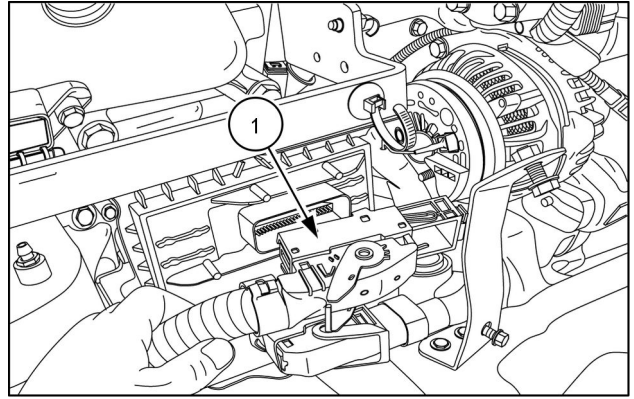

RAIL13TR04226AA 23

24. Remove the bolts (1) and cover for the drop box drive shaft. Set the cover aside.

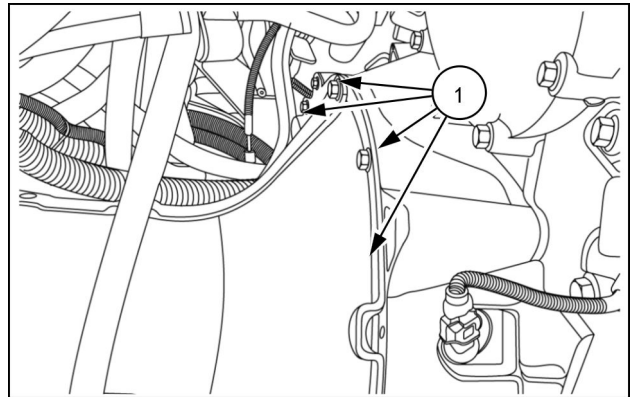

RCPH10CCH813AAB 24

25. Mark the drive shaft (1). Remove the four bolts and disengage the drive shaft from the flywheel.

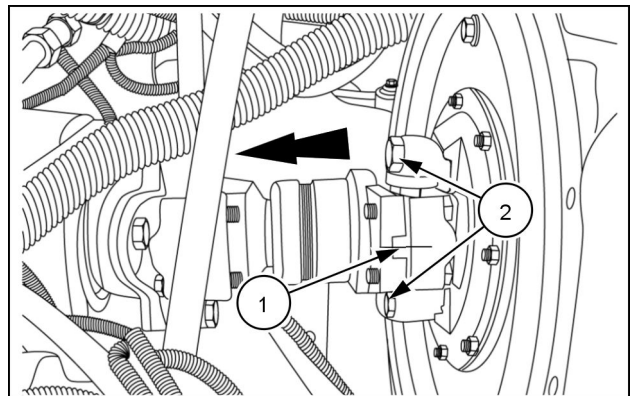

RCPH10CCH817AAB 25

26. Remove the bolts (1) from the plate (2) for the right hand rear engine mount.

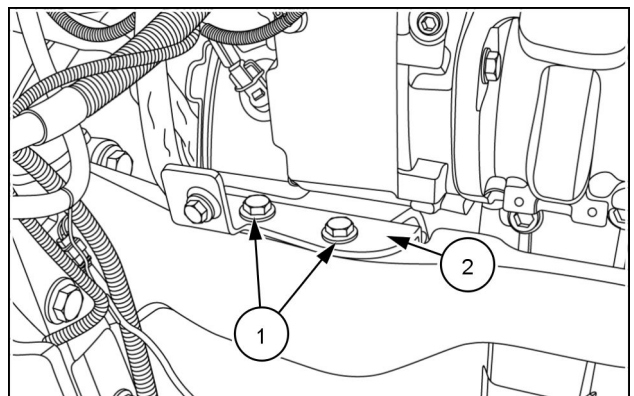

RCPH10CCH925AAB 26

27. Attach appropriately rated lifting equipment to the lifting brackets on the engine. Carefully remove the engine while making certain all harnesses, lines and hoses have been disconnected.

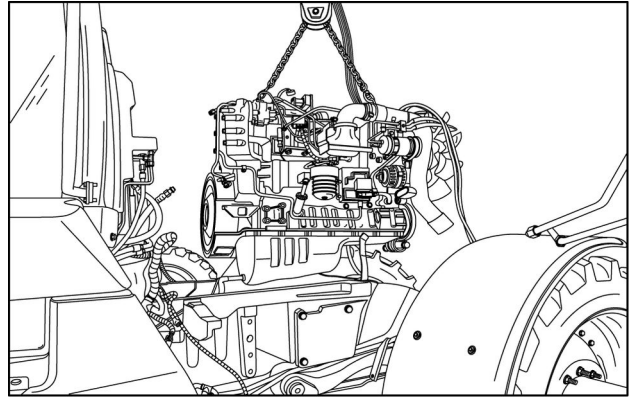

RAIL13TR04247AA 27

28. Remove the right hand rear engine mount. Inspect for wear and/or damage. Replace as required. Repeat for the left hand side.

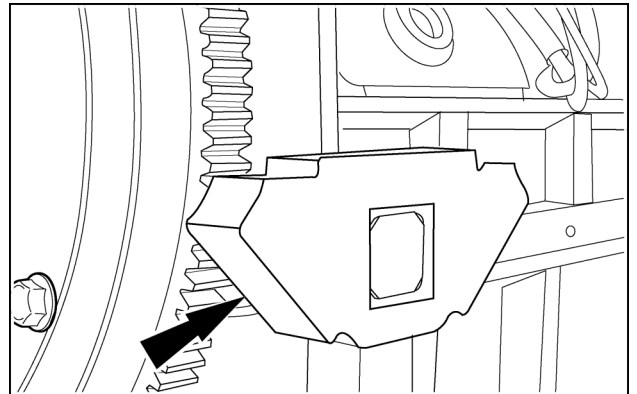

RCPH07CCH166AAB 28

29. Remove the four bolts (1) securing the brackets (2) for the front engine mount.
30. Remove the bolt (3) securing the front engine mount (4).
31. Inspect the mount for wear and/or damage. Replace as required.

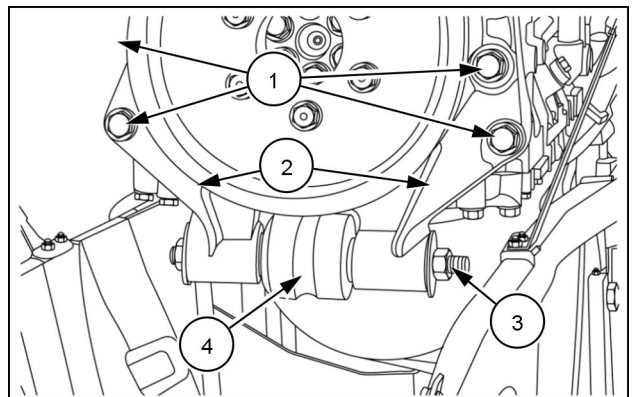

RCPH10CCH833AAB 29

**Next operation:**  
**Engine - Install (10.001)**

## Engine - Install

### Prior operation:

#### Engine - Remove (10.001)

1. If removed, install the front engine mounting brackets (1).
2. Torque the four mounting bolts (2) to **101 – 113 N·m (75 – 83 lb ft)**.
3. Torque the ISO mount support bolt nut (3) to **160 – 220 N·m (118 – 162 lb ft)**.
4. After proper torque is achieved, back the nut (3) off one half to one full turn.

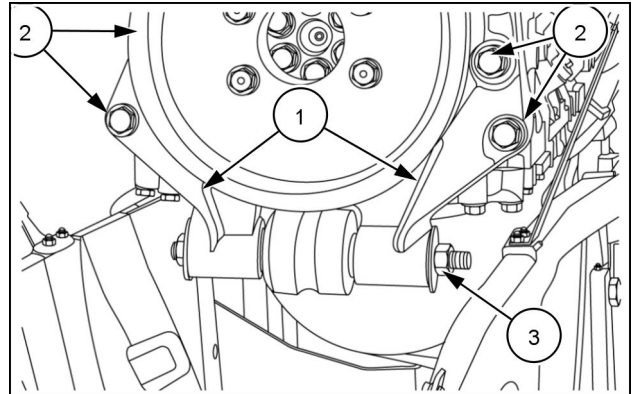

RCPH10CCH833AAB 1

5. Install the right (shown) and left rear engine ISO mounts.

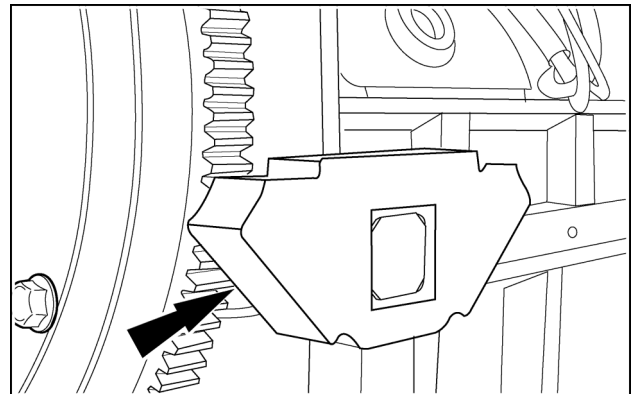

RCPH07CCH166AAB 2

6. Properly support the engine. Raise and move the engine into the front support frame.

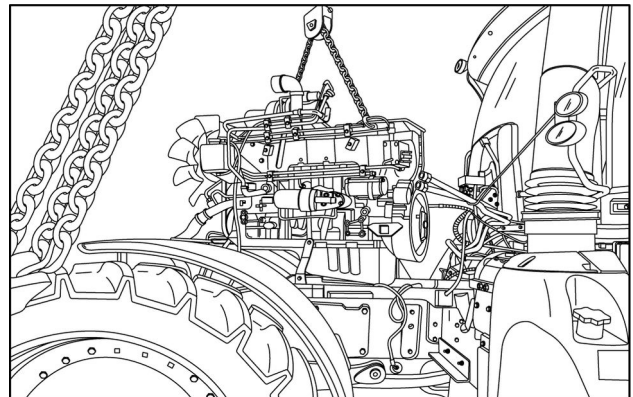

RAIL13TR04248AA 3

7. Install the holding plate (1) for the right rear engine mount with the bolts (2) removed earlier.
8. Torque the bolts to **125 – 150 N·m (92.2 – 110.6 lb ft)**.
9. Install the bolts (3) removed earlier, and torque to **125 – 150 N·m (92 – 111 lb ft)**.
10. Install the hood support bolt and washer (4) and torque to **125 – 150 N·m (92 – 111 lb ft)**.

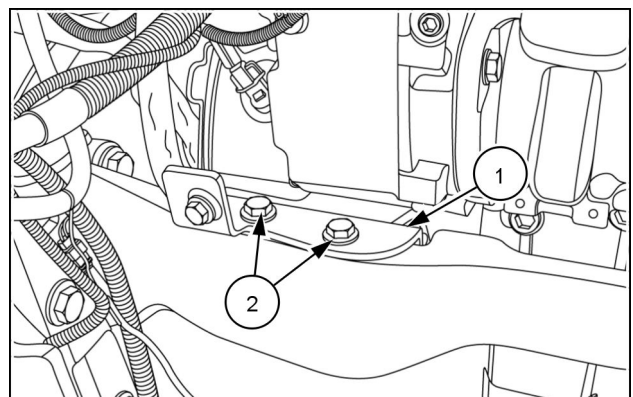

RCPH10CCH925AAB 4

11. Making sure the marks **(1)** are aligned, attach the engine output drive shaft to the engine flywheel.
12. Using the four bolts **(2)** removed earlier to secure the drive shaft to the flywheel.
13. Torque the bolts to **101 – 113 N·m (75 – 83 lb ft)**.

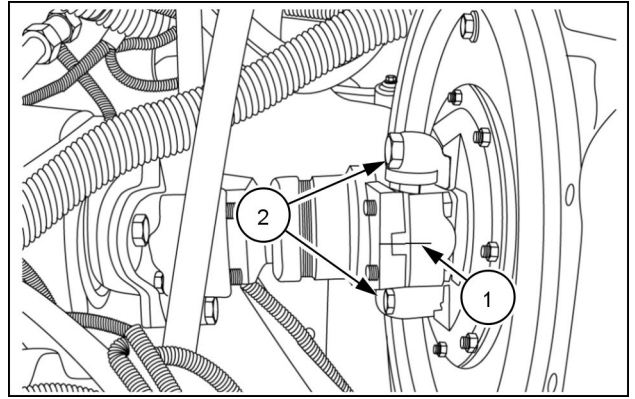

RCPH10CCH817AAB 5

14. Install the engine output drive shaft cover **(1)**. Use the bolts **(2)** removed earlier to secure the cover to the flywheel housing.

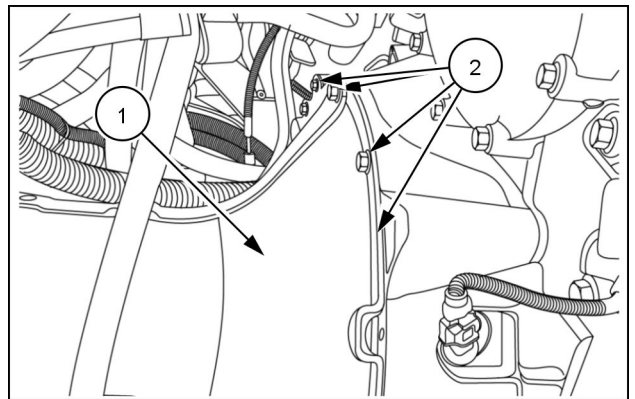

RCPH10CCH813AAB 6

15. Connect the harness connector **(1)** to the engine controller.

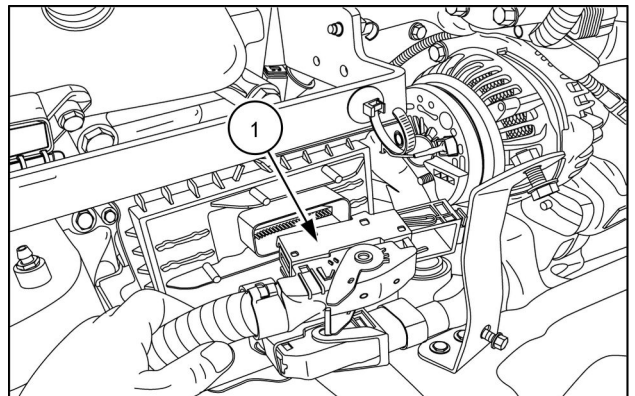

RAIL13TR04226AA 7

16. Connect the alternator output cable **(1)** and secure with the nut removed previously.

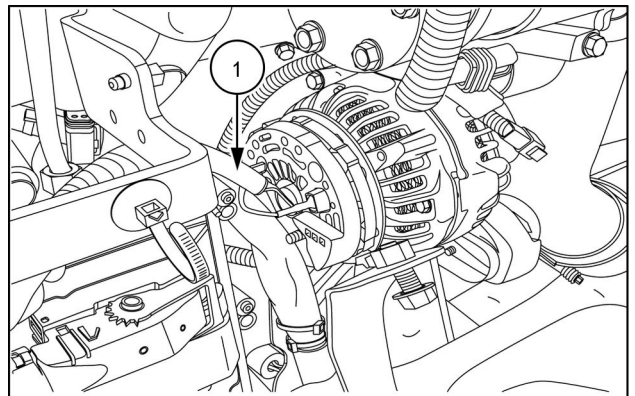

RAIL13TR04231AA 8

17. Connect the alternator excite wire connector (1) and the CAN bus connector (2).

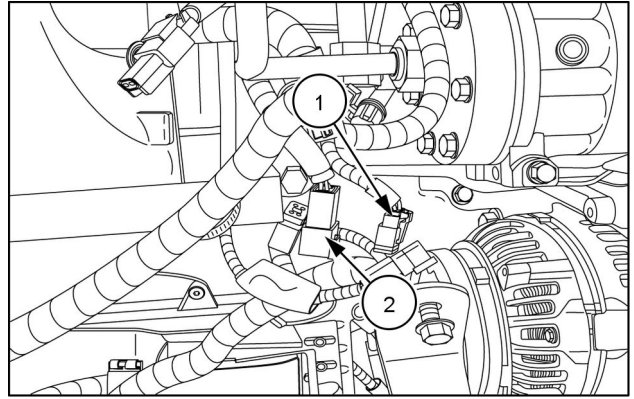

RAIL13TR04221AA 9

18. Connect the harness connector (1) to the A/C pressure switch.

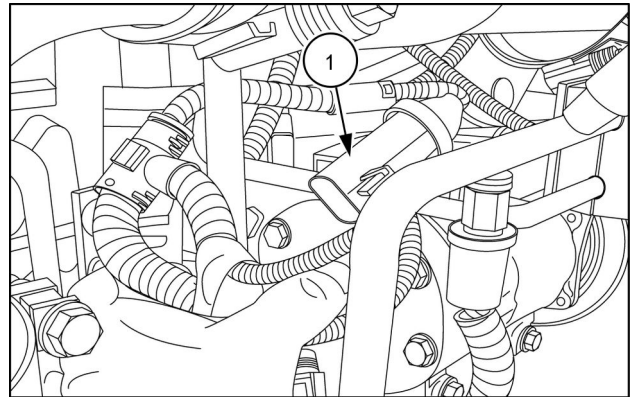

RAIL13TR04223AA 10

19. Connect the ground wire (1) and secure the wire with the A/C compressor mounting bolt (2).

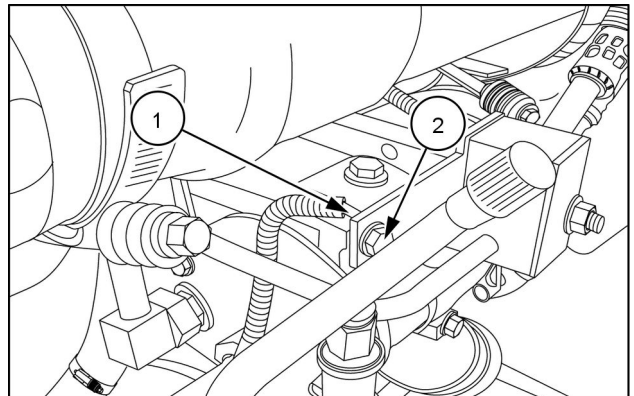

RAIL13TR04224AA 11

20. Connect the harness connector (1) for the fan drive.

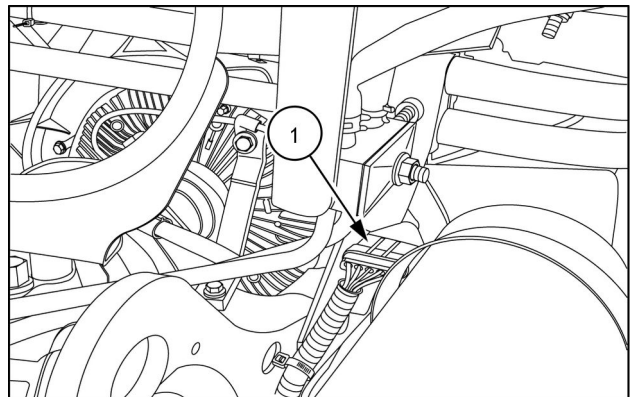

RAIL13TR04220AA 12

21. Connect the vent hose (1) to the intake manifold.

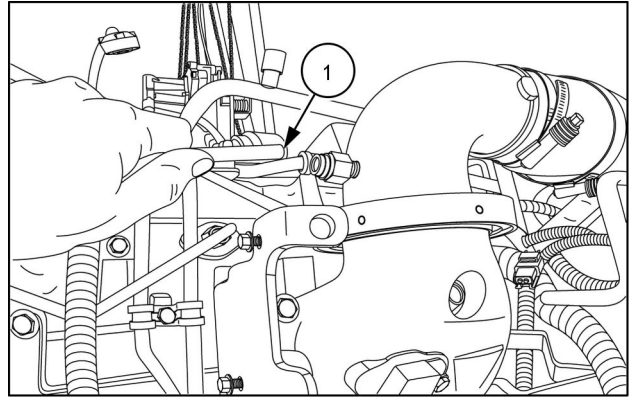

RAIL13TR04218AA 13

22. Connect the harness connector (1) for the engine grid heater and the power supply cable (2).

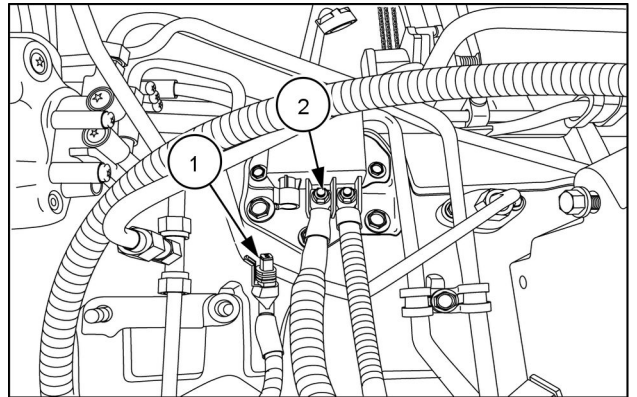

RAIL13TR04219AA 14

23. Install the fuse panel.

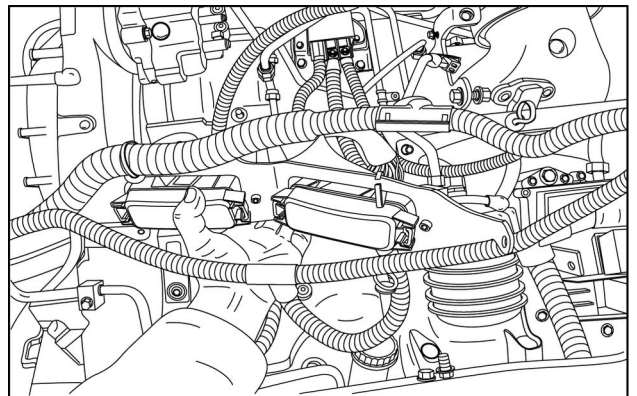

RAIL13TR04214AA 15

24. Secure the fuse panel bracket with the three mounting bolts (1) removed previously. Secure the harness with wire ties.

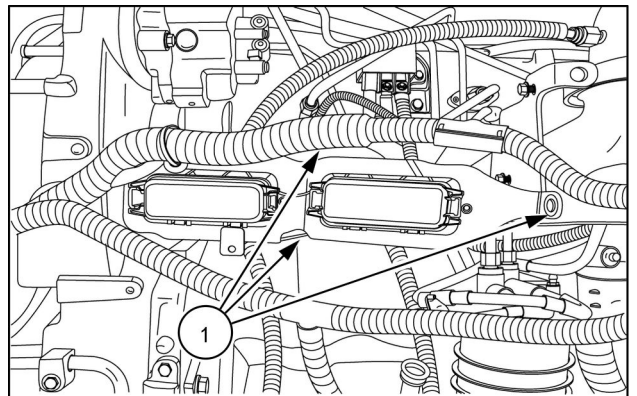

RAIL13TR04216AA 16

25. Connect the oil line (1) and secure with the hose clamp removed previously.

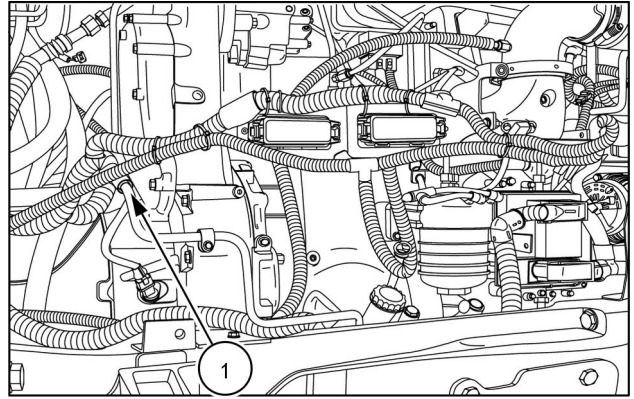

RAIL13TR04213AA 17

26. Lubricate a new O-ring with PAG or mineral oil and install the O-ring. Connect the low pressure A/C line (1).

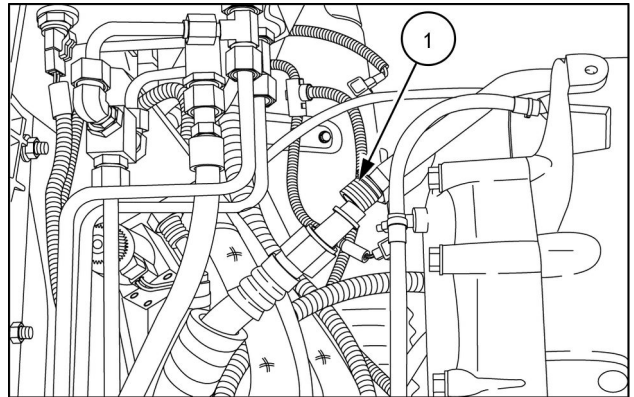

RAIL13TR04228AA 18

27. On the rear of the engine, secure the oil cooler tubes with the tube clamp (1) previously removed.

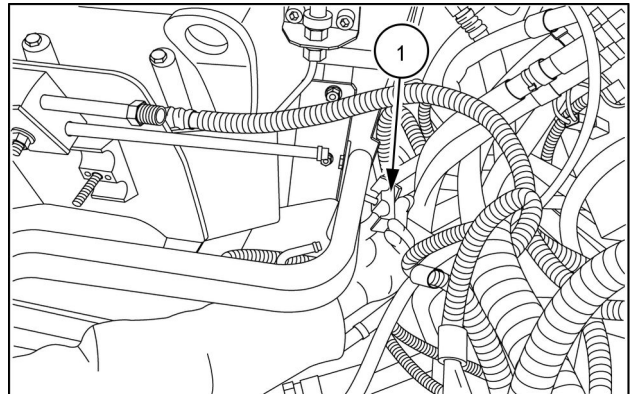

RAIL13TR04236AA 19

28. Connect the front suspended axle electrical connectors (1) if equipped.

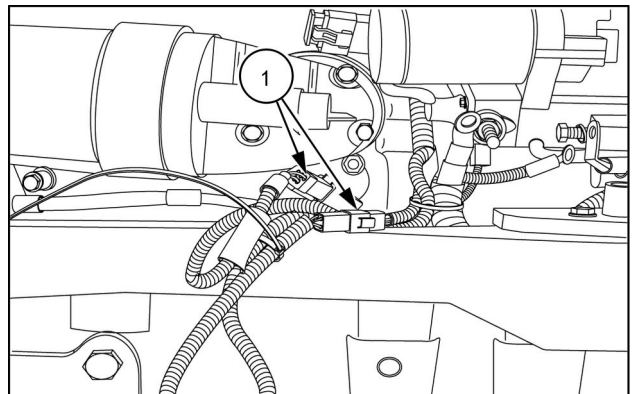

RAIL13TR04237AA 20

29. Install the cover plate for the left hand rear engine mount. Torque the bolts (1) to **125 – 150 N·m (92.2 – 110.6 lb ft)**.

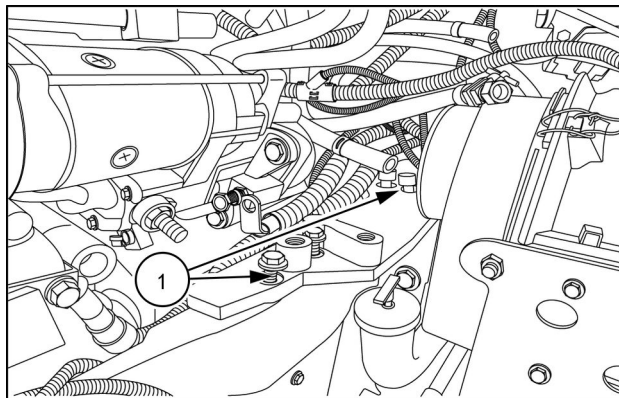

RAIL13TR04243AA 21

30. Lubricate a new O-ring with PAG or mineral oil and install the O-ring; reconnect the high pressure A/C hose (1).
31. Reconnect the coolant lines (2).

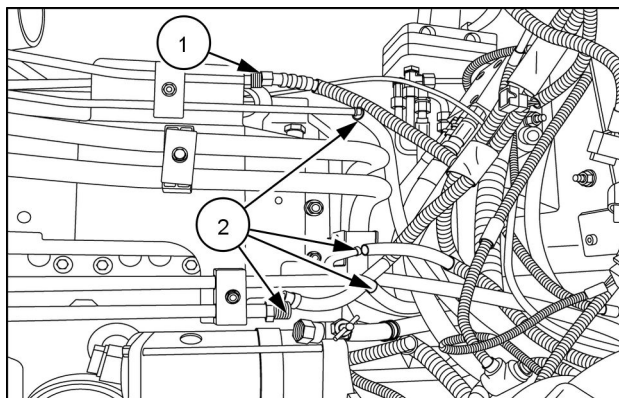

RAIL13TR04230AA 22

32. Install the hood support.

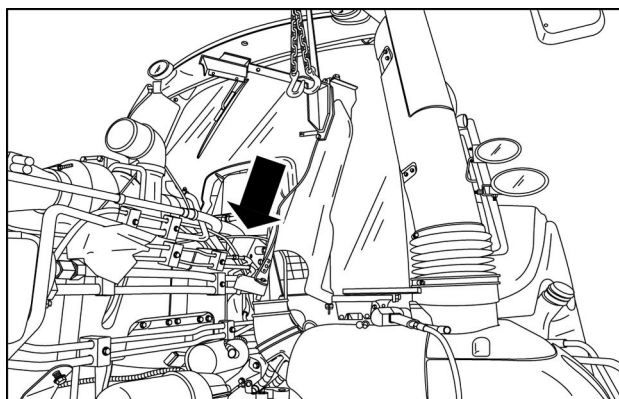

RAIL13TR04212AA 23

33. Torque the bolts (1) to **125 – 150 N·m (92.2 – 110.6 lb ft)**.

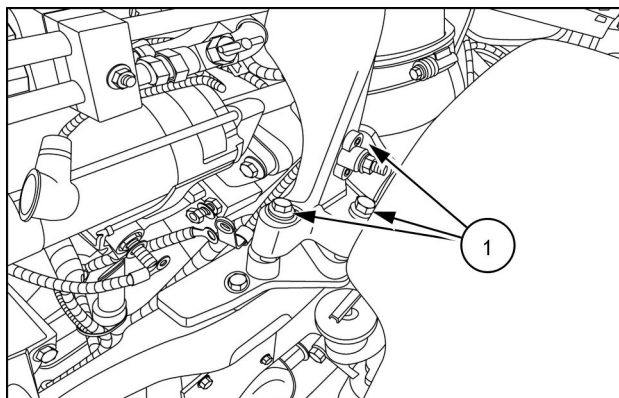

RAIL13TR04209AA 24

34. Connect the starter cables (1) and the auxiliary wire (2).

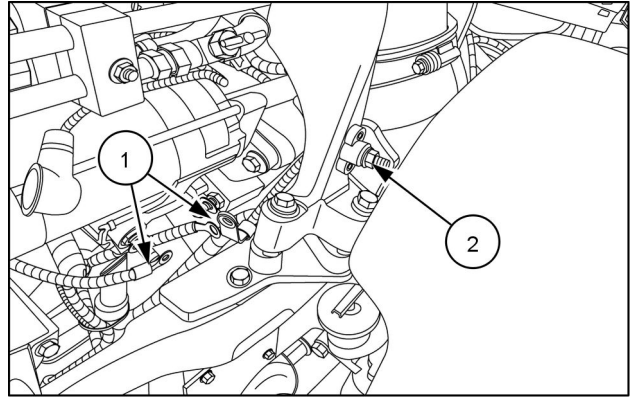

RAIL13TR04209AA 25

35. Install a wire tie (1) to secure the harness to the hood support (2).

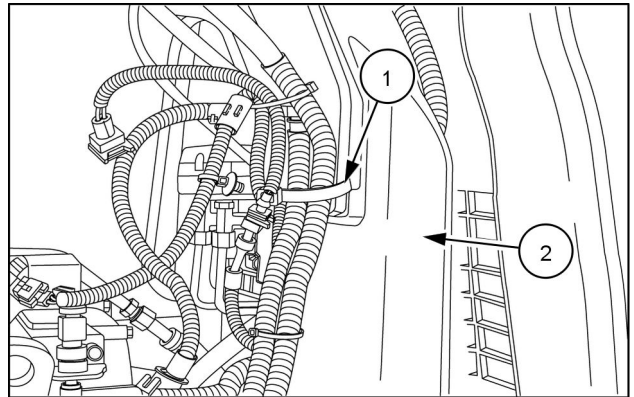

RAIL13TR04204AA 26

36. Install the air intake tube (1) and secure with the hose clamps (2) previously removed.

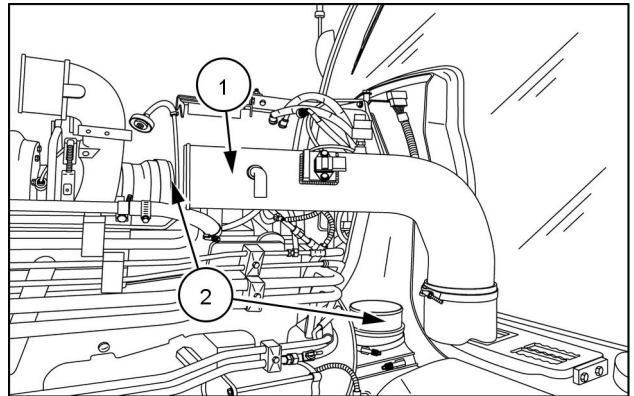

RAIL13TR04211AA 27

37. Connect the harness connectors for the humidity sensor (1) and the air restriction sensor (2). Connect the hose (3) to the air intake tube. Secure the hose with the hose clamp previously removed.

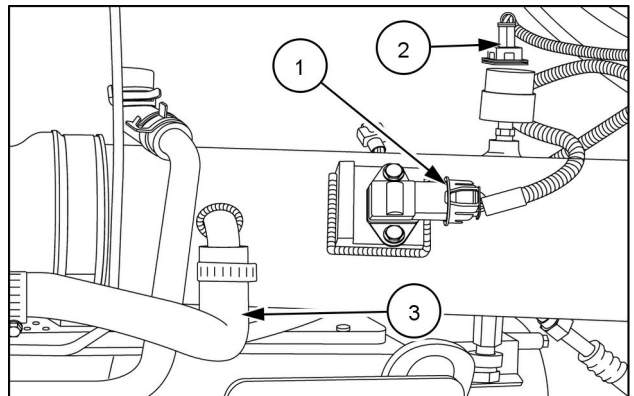

RAIL13TR04202AA 28

**Next operation:**  
**Air conditioning - Evacuate (50.200)**  
**Next operation:**

## Valve cover - Remove - Over head components

Prior operation:

Hood - Remove (90.100)

Prior operation:

Air conditioning - Recover (50.200)

Prior operation:

Engine cooling system - Emptying (10.400)

**NOTE:** During the disassembly of components with O-ring seals, it is recommended that the seals be discarded and new seal installed during assembly.

**NOTE:** Cap all fittings and plug all lines/hoses as they are disconnected.

1. Loosen the hose clamp (1) at the air cooler inlet.

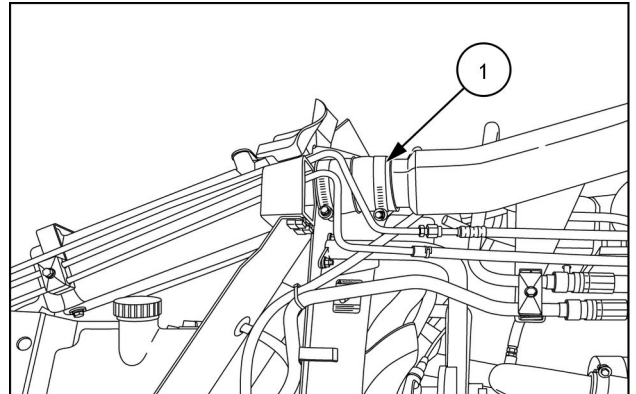

RAIL13TR04527AA 1

2. Loosen the hose clamp (1) on the opposite end of the air cooler inlet and remove the inlet tube.

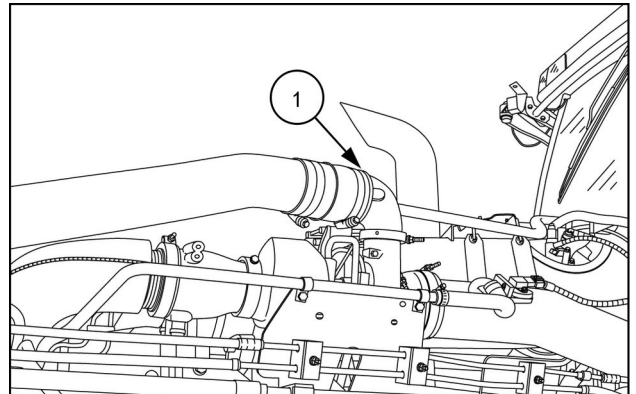

RAIL13TR04526AA 2

3. Remove the oil cooler tube clamp (1).

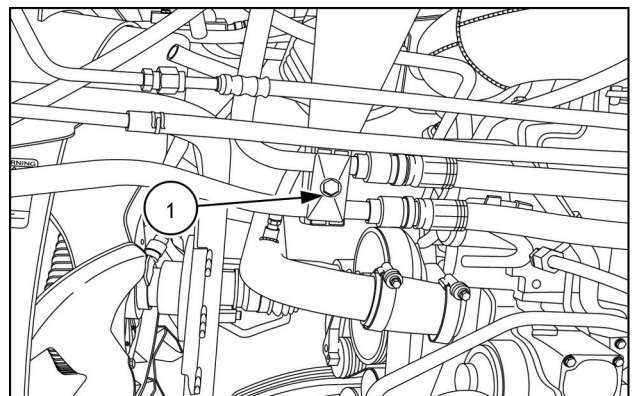

RAIL13TR04534AA 3

4. Disconnect the hydraulic lines (1) using special tool 38000795.

**NOTE:** Be prepared to collect some hydraulic oil by placing a pan under the fitting.

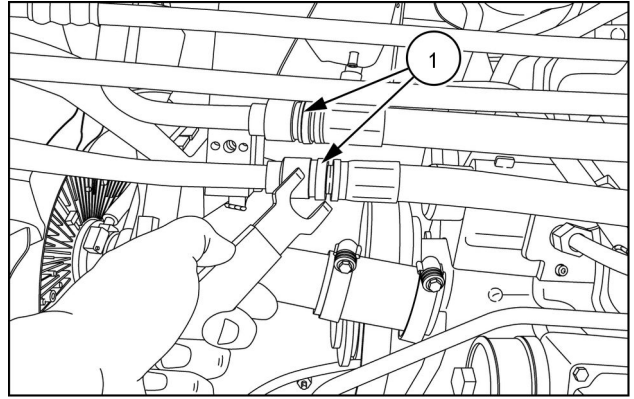

RAIL13TR04535AA 4

5. Disconnect the air conditioning high pressure hose from the tube fitting (1) and the coolant hose (2).

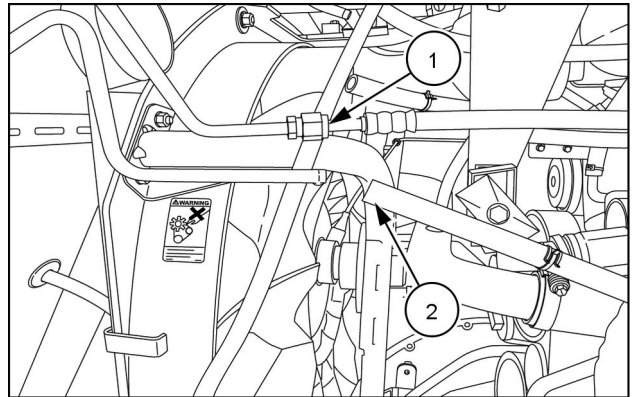

RAIL13TR04537AA 5

6. Remove the hydraulic tube clamp (1) from the hydraulic tube.

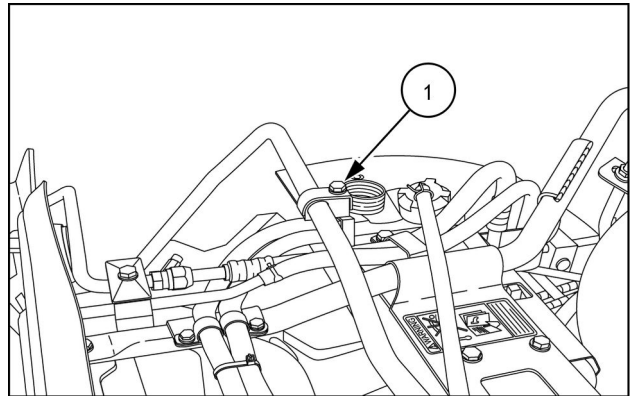

RAIL13TR04536AA 6

7. Remove the hydraulic cooler lines (1) on each side of the cooler (left side shown).

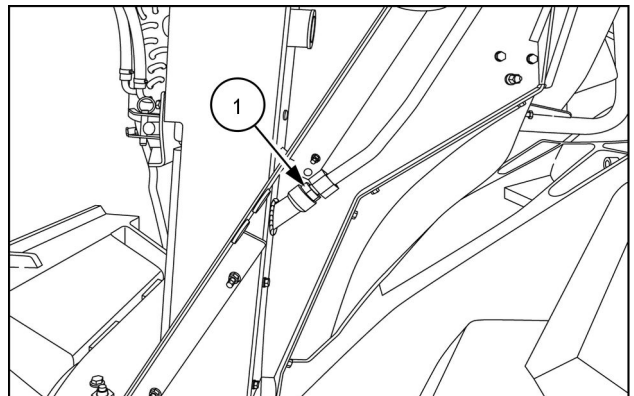

RAIL13TR04530AA 7

8. Disconnect the low pressure A/C line (1), loosen the hose clamps (2) securing the overflow hose.

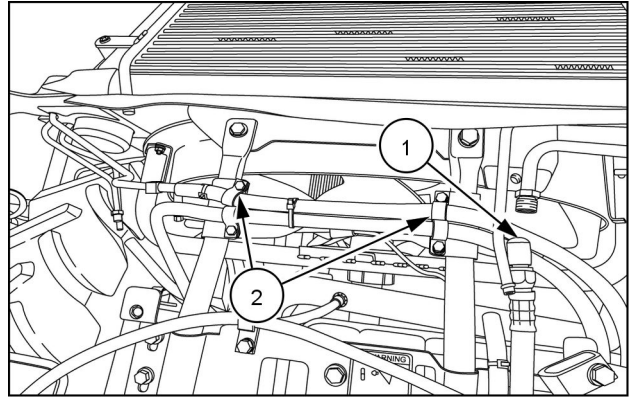

RAIL13TR04542AA 8

9. Disconnect the overflow hose (1) and remove the top bracket mounting bolts (2).

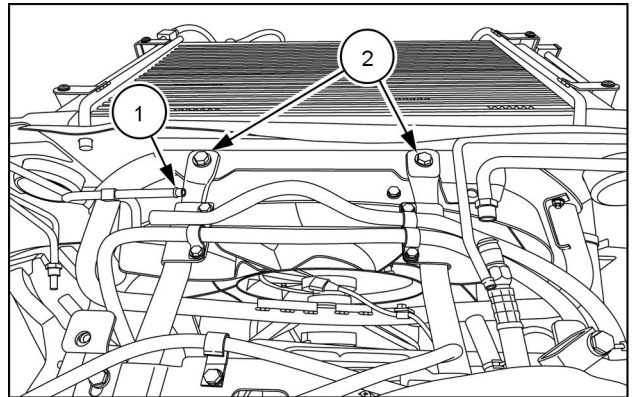

RAIL13TR04543AA 9

10. Remove the two mounting bolts (1) on the rear of the top bracket and remove the bracket.

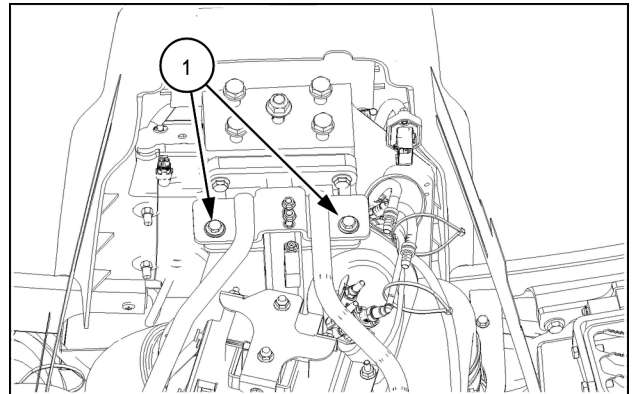

RAIL14TR00391AA 10

11. Disconnect the electrical connector (1), the coolant hoses (2) and the DEF fluid line (3) from the dosing valve.

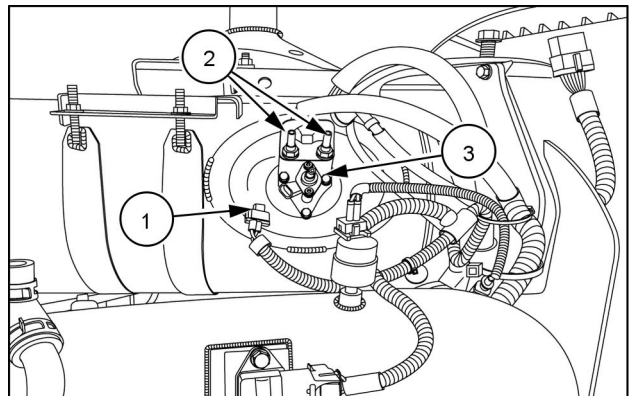

RAIL13TR04188AA 11

12. Remove the NOx sensor (1) from the exhaust pipe.

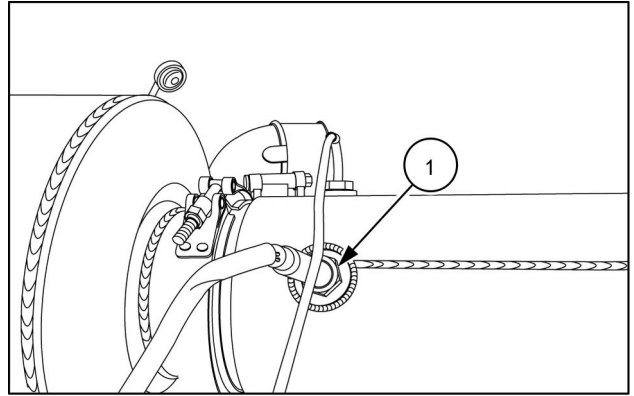

RAIL13TR04185AA 12

13. Disconnect the electrical connector (1) for the temperature sensor.

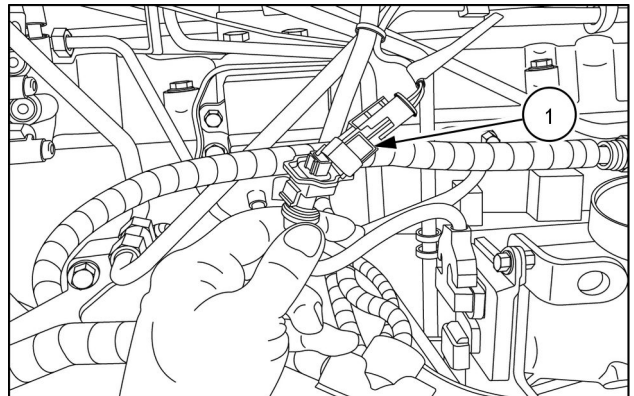

RAIL13TR04183AA 13

14. Disengage the clamp (1) from the exhaust pipe to the turbo.

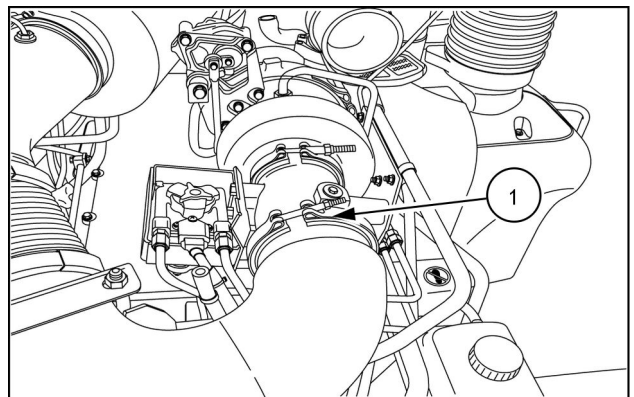

RAIL13TR04177AA 14

15. Disengage the clamp (1) from the exhaust pipe to the Diesel oxidation catalyst (DOC)

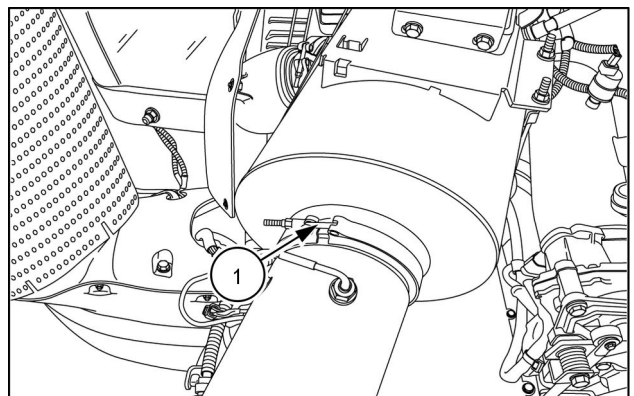

RAIL13TR04180AA 15



**Suggest:**

**If the above button click is invalid.**

**Please download this document**

**first, and then click the above link**

**to download the complete manual.**

**Thank you so much for reading**

16. Remove the two nuts (1) from the C-clamp (2) securing the exhaust pipe. Remove the exhaust pipe and set aside.

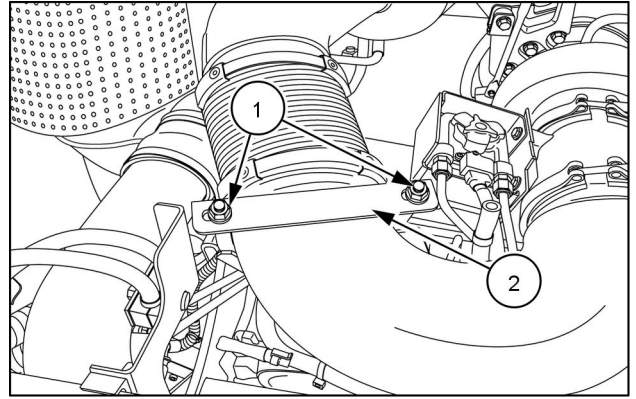

RAIL13TR04181AA 16

17. Disengage the clamp (1) from the outlet side of the catalyst.

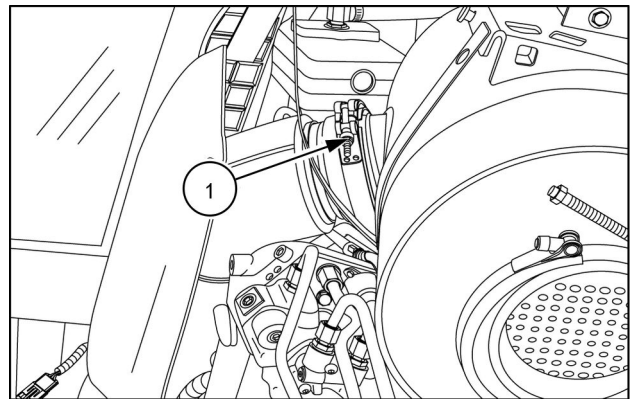

RAIL13TR04192AA 17

18. Remove the two nuts (1) from the catalyst mounting straps.

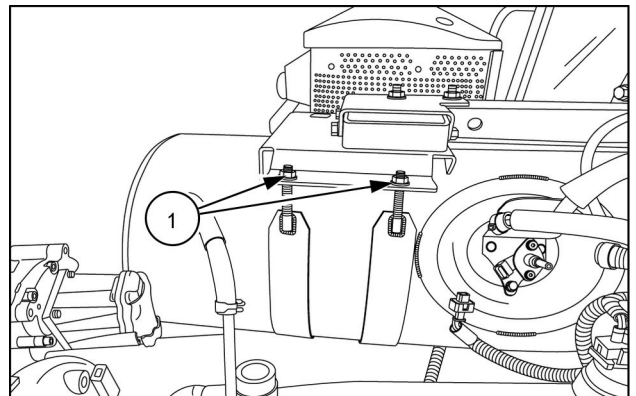

RAIL13TR04190AA 18

19. Slide the catalyst forward from under the support bracket. Remove the catalyst.

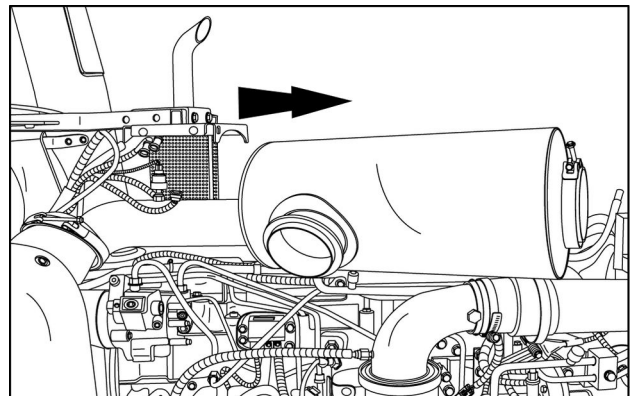

RAIL13TR04193AA 19

**Next operation:**  
Remove the valve cover.  
**Next operation:**

**<https://www.ebooklibonline.com>**

Hello dear friend!

Thank you very much for reading.

Enter the link into your browser.

The full manual is available for immediate download.

**<https://www.ebooklibonline.com>**