

Magnum™ 250

Magnum™ 280

Magnum™ 310

Magnum™ 340

Magnum™ 380

Continuously Variable Transmission (CVT)

Tractor

PIN ZERF08100 and above

SERVICE MANUAL

Part number 47794733

1st edition English

November 2014

Copyright © 2014 CNH Industrial America LLC. All Rights Reserved.





SERVICE MANUAL

Magnum™ 250 696110724 CVT TIER 4B [ZERF08100 -]
Magnum™ 280 696110734 CVT TIER 4B [ZERF08100 -]
Magnum™ 310 696110744 CVT TIER 4B [ZERF08100 -]
Magnum™ 340 696110754 CVT TIER 4b [ZERF08100 -]
Magnum™ 380 696110764 CVT TIER 4B [ZERF08100 -]

Link Product / Engine

Product	Market Product	Engine
Magnum™ 250 696110724 CVT TIER 4B [ZERF08100 -]	Europe	F2CFE613G*B001
Magnum™ 280 696110734 CVT TIER 4B [ZERF08100 -]	Europe	F2CFE614G*B002
Magnum™ 310 696110744 CVT TIER 4B [ZERF08100 -]	Europe	F2CFE614D*B002
Magnum™ 340 696110754 CVT TIER 4b [ZERF08100 -]	Europe	F2CFE614C*B002
Magnum™ 380 696110764 CVT TIER 4B [ZERF08100 -]	Europe	F2CFE614A*B002

<https://www.ebooklibonline.com>

Hello dear friend!

Thank you very much for reading.

Enter the link into your browser.

The full manual is available for immediate download.

<https://www.ebooklibonline.com>

Contents

INTRODUCTION

Engine	10
[10.001] Engine and crankcase	10.1
[10.101] Cylinder heads	10.2
[10.202] Air cleaners and lines	10.3
[10.216] Fuel tanks	10.4
[10.218] Fuel injection system.....	10.5
[10.304] Engine lubrication system.....	10.6
[10.310] Aftercooler.....	10.7
[10.400] Engine cooling system	10.8
[10.414] Fan and drive	10.9
[10.500] Selective Catalytic Reduction (SCR) exhaust treatment.....	10.10
Power coupling	19
[19.100] Drive shaft.....	19.1
[19.110] Flywheel damper	19.2
[19.120] Drive shaft shield assembly	19.3
Transmission	21
[21.504] Continuously Variable Transmission (CVT)	21.1
[21.505] Continuously Variable Transmission (CVT) external controls.....	21.2
[21.506] Continuously Variable Transmission (CVT) lubrication system	21.3
[21.507] Continuously Variable Transmission (CVT) internal components.....	21.4
[21.900] Hydraulic pump drive.....	21.5
Four-Wheel Drive (4WD) system	23
[23.202] Electro-hydraulic control	23.1
[23.314] Drive shaft.....	23.2
Front axle system	25

[25.100] Powered front axle	25.1
[25.102] Front bevel gear set and differential	25.2
[25.108] Final drive hub, steering knuckles, and shafts	25.3
[25.122] Axle suspension control.....	25.4
Rear axle system.....	27
[27.100] Powered rear axle.....	27.1
[27.106] Rear bevel gear set and differential.....	27.2
Power Take-Off (PTO).....	31
[31.104] Rear electro-hydraulic control.....	31.1
[31.110] One-speed rear Power Take-Off (PTO)	31.2
[31.114] Two-speed rear Power Take-Off (PTO)	31.3
[31.146] Front Power Take-Off (PTO)	31.4
Brakes and controls	33
[33.110] Parking brake or parking lock	33.1
[33.202] Hydraulic service brakes	33.2
[33.220] Trailer brake hydraulic control.....	33.3
[33.224] Trailer brake pneumatic control	33.4
[33.240] Emergency brake	33.5
Hydraulic systems.....	35
[35.000] Hydraulic systems.....	35.1
[35.102] Pump control valves.....	35.2
[35.106] Variable displacement pump	35.3
[35.114] Three-point hitch control valve	35.4
[35.124] Three-point hitch hydraulic adjustment	35.5
[35.204] Remote control valves	35.6
[35.300] Reservoir, cooler, and filters.....	35.7
[35.304] Combination pump units	35.8
Hitches, drawbars, and implement couplings.....	37

[37.110] Rear three-point hitch	37.1
[37.162] Front hitch	37.2
Steering	41
[41.101] Steering control	41.1
[41.200] Hydraulic control components	41.2
[41.206] Pump	41.3
[41.432] Autoguidance steering	41.4
[41.910] Auxiliary steering	41.5
Wheels	44
[44.520] Rear wheels	44.1
Cab climate control	50
[50.100] Heating	50.1
[50.200] Air conditioning	50.2
[50.300] Cab pressurizing system	50.3
Electrical systems	55
[55.010] Fuel injection system	55.1
[55.012] Engine cooling system	55.2
[55.014] Engine intake and exhaust system	55.3
[55.024] Transmission control system	55.4
[55.045] Front axle control system	55.5
[55.046] Rear axle control system	55.6
[55.050] Heating, Ventilation, and Air-Conditioning (HVAC) control system	55.7
[55.051] Cab Heating, Ventilation, and Air-Conditioning (HVAC) controls	55.8
[55.100] Harnesses and connectors	55.9
[55.130] Rear three-point hitch electronic control system	55.10
[55.201] Engine starting system	55.11
[55.301] Alternator	55.12
[55.302] Battery	55.13

[55.510] Cab or platform harnesses and connectors	55.14
[55.512] Cab controls	55.15
[55.513] Cab transmission controls	55.16
[55.518] Wiper and washer system	55.17
[55.640] Electronic modules	55.18
[55.988] Selective Catalytic Reduction (SCR) electrical system	55.19
[55.DTC] FAULT CODES	55.20
Platform, cab, bodywork, and decals	90
[90.100] Engine hood and panels	90.1
[90.102] Engine shields, hood latches, and trims	90.2
[90.124] Pneumatically-adjusted operator seat	90.3
[90.150] Cab	90.4
[90.151] Cab interior	90.5
[90.160] Cab interior trim and panels	90.6



INTRODUCTION

Foreword - Important notice regarding equipment servicing

All repair and maintenance work listed in this manual must be carried out only by qualified dealership personnel, strictly complying with the instructions given, and using, whenever possible, the special tools.

Anyone who performs repair and maintenance operations without complying with the procedures provided herein shall be responsible for any subsequent damages.

The manufacturer and all the organizations of its distribution chain, including - without limitation - national, regional, or local dealers, reject any responsibility for damages caused by parts and/or components not approved by the manufacturer, including those used for the servicing or repair of the product manufactured or marketed by the manufacturer. In any case, no warranty is given or attributed on the product manufactured or marketed by the manufacturer in case of damages caused by parts and/or components not approved by the manufacturer.

The information in this manual is up-to-date at the date of the publication. It is the policy of the manufacturer for continuous improvement. Some information could not be updated due to modifications of a technical or commercial type, or changes to the laws and regulations of different countries.

In case of questions, refer to your CASE IH Sales and Service Networks.

Safety rules

Personal safety



This is the safety alert symbol. It is used to alert you to potential personal injury hazards. Obey all safety messages that follow this symbol to avoid possible death or injury.

Throughout this manual you will find the signal words DANGER, WARNING, and CAUTION followed by special instructions. These precautions are intended for the personal safety of you and those working with you.

Read and understand all the safety messages in this manual before you operate or service the machine.

 DANGER indicates a hazardous situation that, if not avoided, will result in death or serious injury.

 WARNING indicates a hazardous situation that, if not avoided, could result in death or serious injury.

 CAUTION indicates a hazardous situation that, if not avoided, could result in minor or moderate injury.

FAILURE TO FOLLOW DANGER, WARNING, AND CAUTION MESSAGES COULD RESULT IN DEATH OR SERIOUS INJURY.

Machine safety

NOTICE: Notice indicates a situation that, if not avoided, could result in machine or property damage.

Throughout this manual you will find the signal word Notice followed by special instructions to prevent machine or property damage. The word Notice is used to address practices not related to personal safety.

Information

NOTE: Note indicates additional information that clarifies steps, procedures, or other information in this manual.

Throughout this manual you will find the word Note followed by additional information about a step, procedure, or other information in the manual. The word Note is not intended to address personal safety or property damage.

Safety rules - General maintenance safety

General maintenance safety

Keep the area used for servicing the machine clean and dry. Clean up spilled fluids.

Service the machine on a firm, level surface.

Install guards and shields after you service the machine.

Close all access doors and install all panels after servicing the machine.

Do not attempt to clean, lubricate, clear obstructions, or make adjustments to the machine while it is in motion or while the engine is running.

Always make sure that working area is clear of tools, parts, other persons and pets before you start operating the machine.

Unsupported hydraulic cylinders can lose pressure and drop the equipment, causing a crushing hazard. Do not leave equipment in a raised position while parked or during service, unless the equipment is securely supported.

Jack or lift the machine only at jack or lift points indicated in this manual.

Incorrect towing procedures can cause accidents. When you tow a disabled machine follow the procedure in this manual. Use only rigid tow bars.

Stop the engine, remove the key, and relieve pressure before you connect or disconnect fluid lines.

Stop the engine and remove the key before you connect or disconnect electrical connections.

Scalding can result from incorrect removal of coolant caps. Cooling systems operate under pressure. Hot coolant can spray out if you remove a cap while the system is hot. Allow the system to cool before you remove the cap. When you remove the cap, turn it slowly to allow pressure to escape before you completely remove the cap.

Replace damaged or worn tubes, hoses, electrical wiring, etc.

The engine, transmission, exhaust components, and hydraulic lines may become hot during operation. Take care when you service such components. Allow surfaces to cool before you handle or disconnect hot components. Wear protective equipment when appropriate.

When welding, follow the instructions in the manual. Always disconnect the battery before you weld on the machine. Always wash your hands after you handle battery components.



SERVICE MANUAL

Engine

Magnum™ 250 696110724 CVT TIER 4B [ZERF08100 -]
Magnum™ 280 696110734 CVT TIER 4B [ZERF08100 -]
Magnum™ 310 696110744 CVT TIER 4B [ZERF08100 -]
Magnum™ 340 696110754 CVT TIER 4b [ZERF08100 -]
Magnum™ 380 696110764 CVT TIER 4B [ZERF08100 -]

Engine - Remove

Prior operation:

Battery - Disconnect (55.302)

Prior operation:

Hood - Remove (90.100)

Prior operation:

Side shield - Remove (90.102)

Prior operation:

Air conditioning - Recover (50.200)

Prior operation:

Engine cooling system - Emptying (10.400)

Prior operation:

Engine cooling system - Remove (10.400)

Prior operation:

Diesel Oxidation Catalyst (DOC) - Remove (10.500)

NOTE: Clean all fittings before disconnecting.

NOTE: Cap or plug all lines and ports when disconnecting hydraulic components.

1. Disconnect the humidity sensor (1) and the air restriction sensor (2). Disengage the hose clamp (3) and disconnect the hose from the air intake tube.

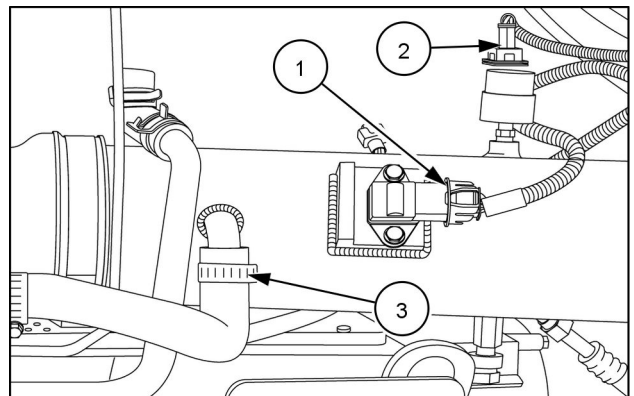

RAIL13TR04202AA 1

2. Disconnect the clamps (1) from each end of the air intake tube and remove the tube.

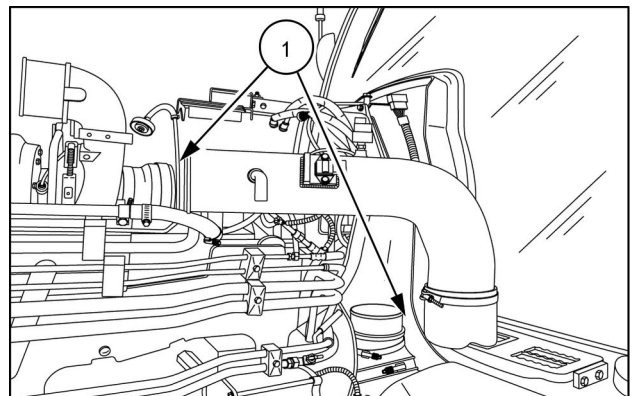

RAIL13TR04211AA 2

3. Cut the wire tie (1) securing the harness to the hood support (2).

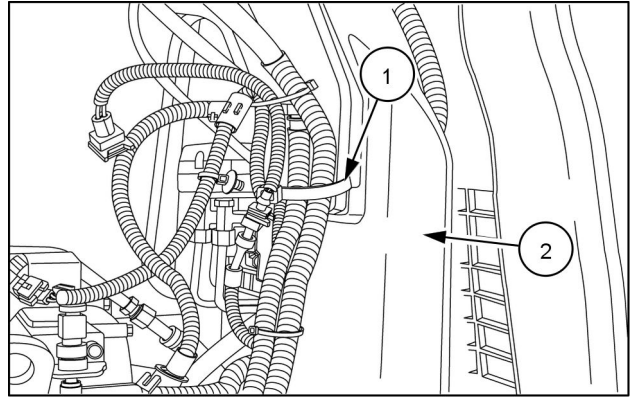

RAIL13TR04204AA 3

4. Disconnect the starter cables (1) and the auxiliary wire (2).

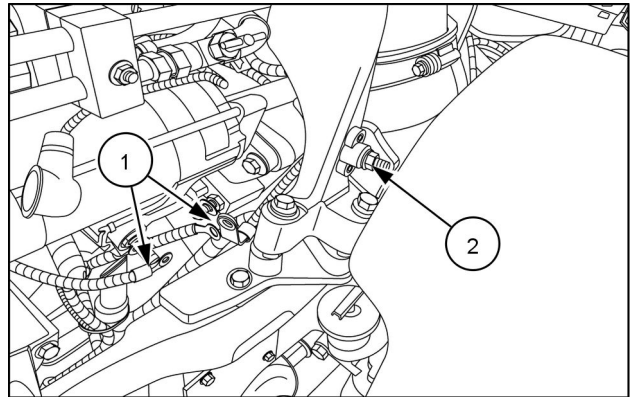

RAIL13TR04209AA 4

5. Remove the three bolts (1) securing the hood support to the frame.

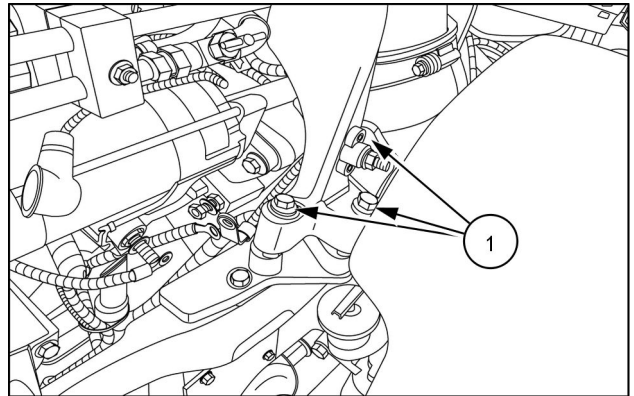

RAIL13TR04209AA 5

6. Remove the hood support.

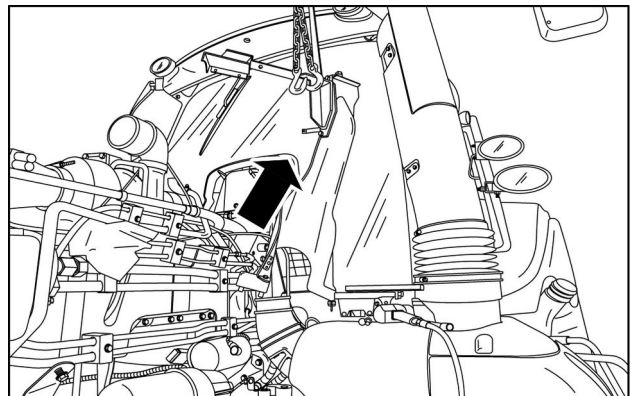

RAIL13TR04212AA 6

7. Disconnect the high pressure A/C hose (1) and the coolant lines (2). Cap or plug all fittings and lines.

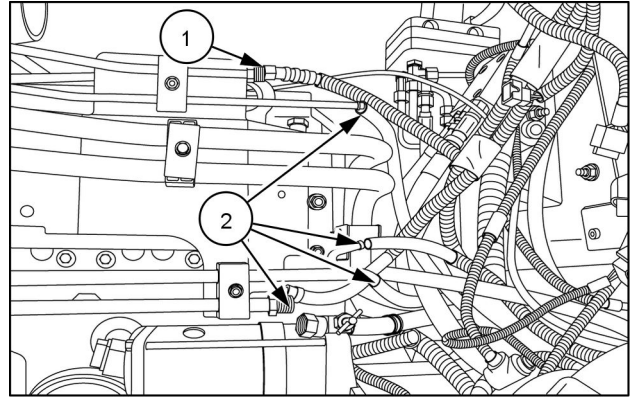

RAIL13TR04230AA 7

8. Remove the two bolts (1) from the rear engine mount plate.

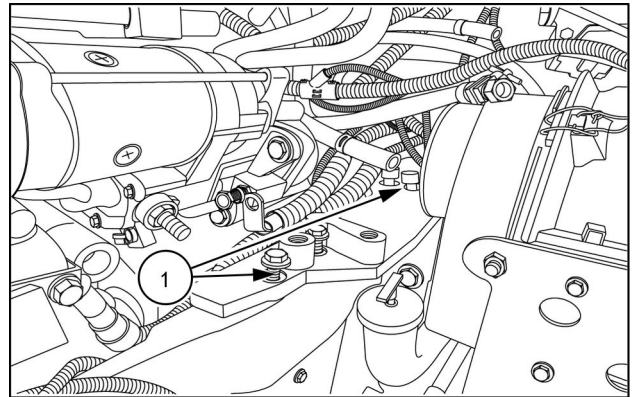

RAIL13TR04243AA 8

9. Remove the engine mount cover plate.

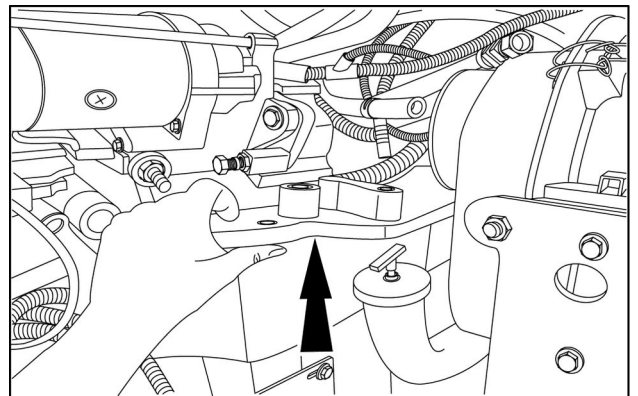

RAIL13TR04244AA 9

10. Disconnect the front suspended axle electrical connectors (1) if equipped.

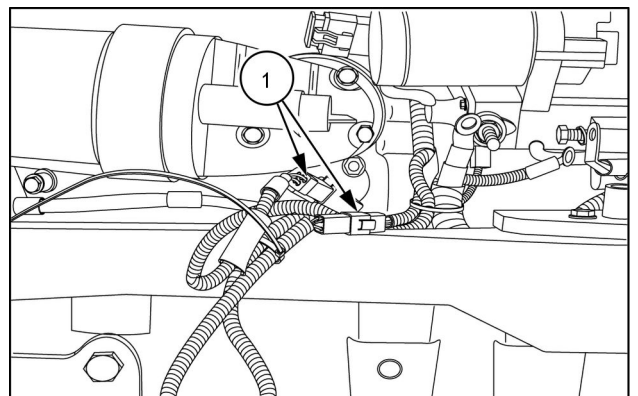

RAIL13TR04237AA 10

11. On the rear of the engine, remove the oil cooler tube clamp (1). Move the oil cooler lines to the side.

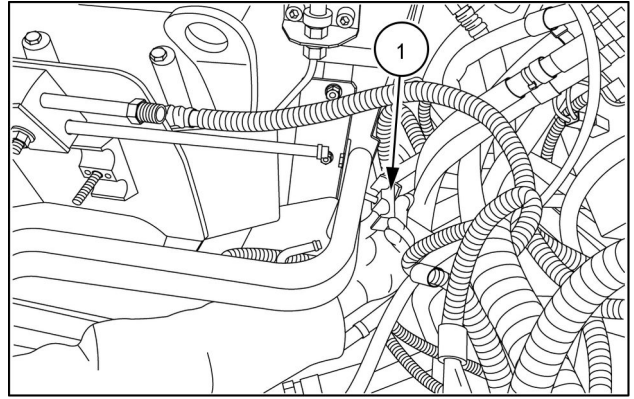

RAIL13TR04236AA 11

12. Disconnect the low pressure A/C line (1). Cap or plug all fittings and hoses.

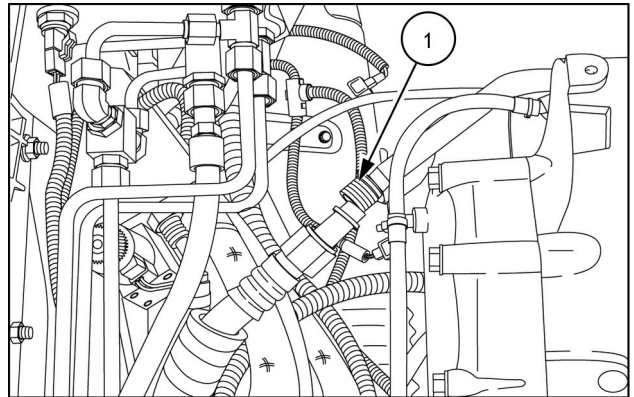

RAIL13TR04228AA 12

13. Disengage the hose clamp and disconnect the engine controller oil line (1).

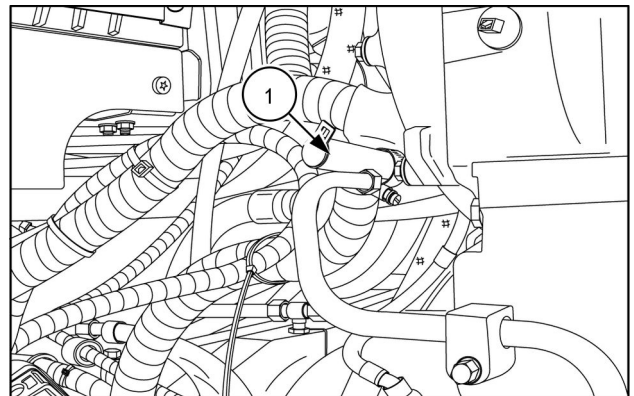

RAIL13TR04227AA 13

14. Remove the three mounting bolts (1) securing the fuse panel bracket.

NOTE: Cut any wire ties securing the harness.

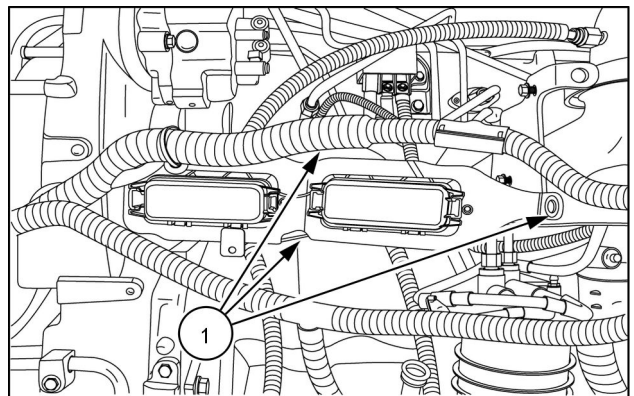

RAIL13TR04216AA 14

15. Remove the fuse panel.

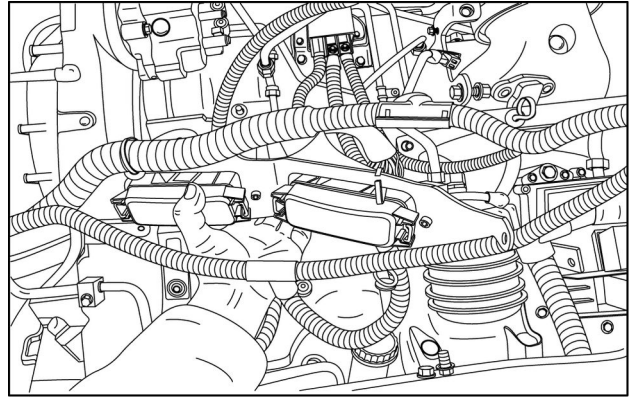

RAIL13TR04214AA 15

16. Disconnect the harness connector (1) for the engine grid heater and the power supply cable (2).

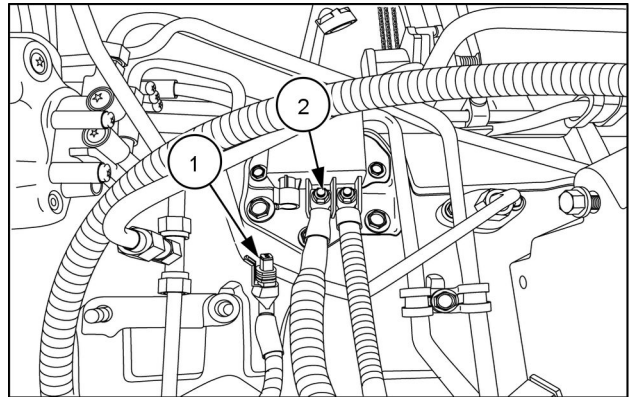

RAIL13TR04219AA 16

17. Disconnect the vent hose (1) from the intake manifold.

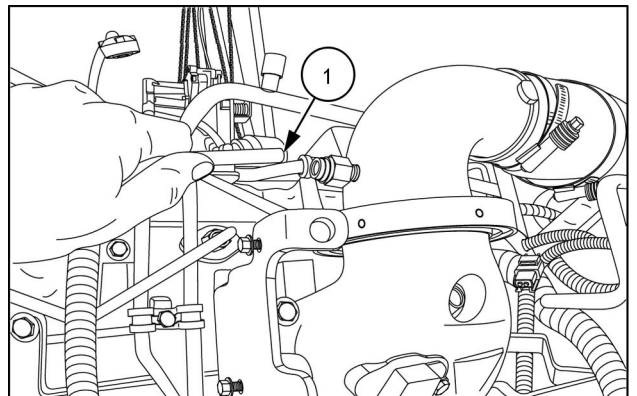

RAIL13TR04218AA 17

18. Disconnect the harness connector (1) for the fan drive.

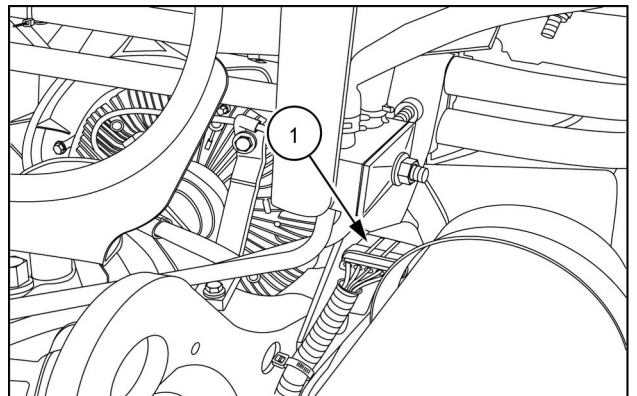

RAIL13TR04220AA 18

19. Remove the A/C compressor mounting bolt (1) and disconnect the ground wire (2).

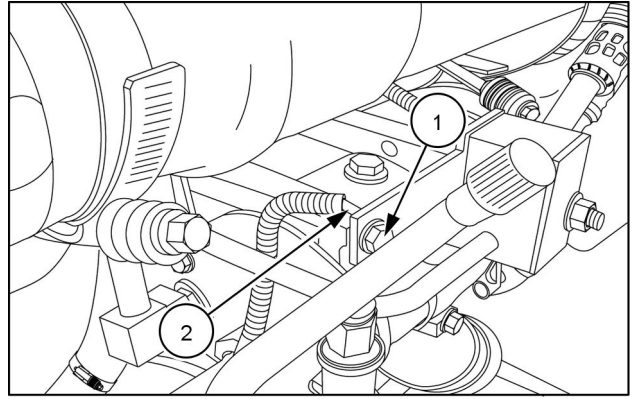

RAIL13TR04224AA 19

20. Disconnect the harness connector (1) to the A/C pressure switch.

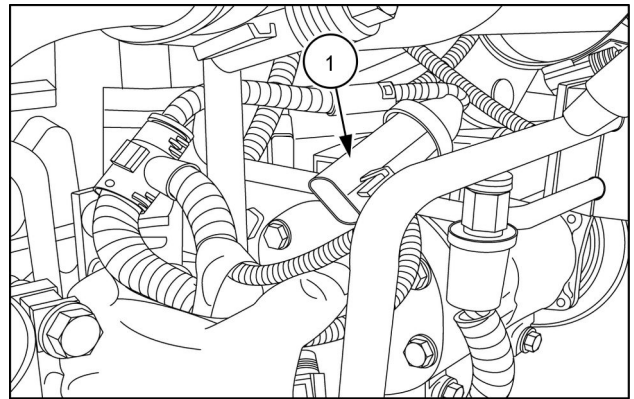

RAIL13TR04223AA 20

21. Disconnect the alternator excite wire connector (1) and the CAN bus connector (2).

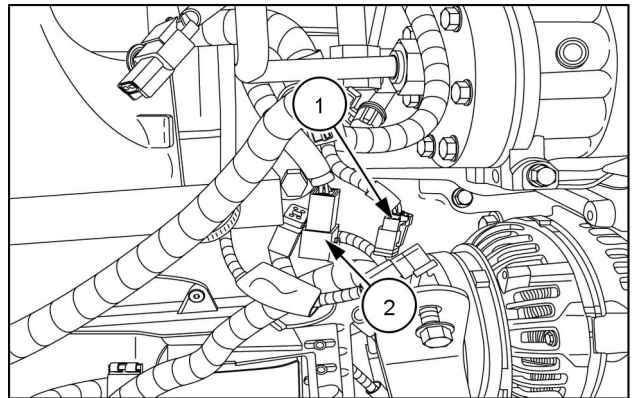

RAIL13TR04221AA 21

22. Remove the nut and disengage the alternator output cable (2).

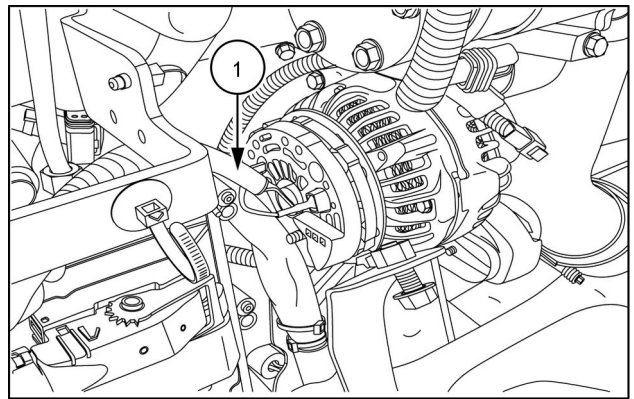

RAIL13TR04231AA 22

23. Disconnect the engine controller connector (1).

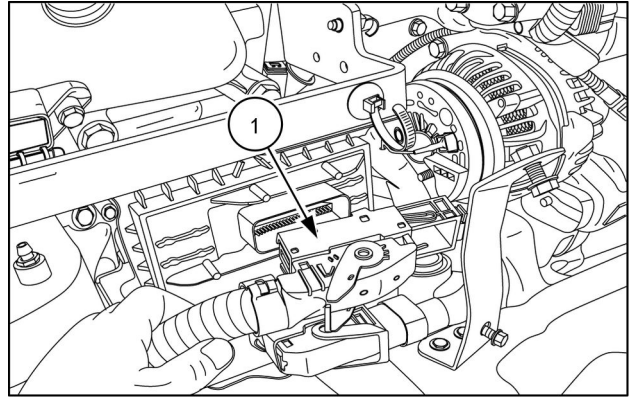

RAIL13TR04226AA 23

24. Remove the bolts (1) and cover for the drop box drive shaft. Set the cover aside.

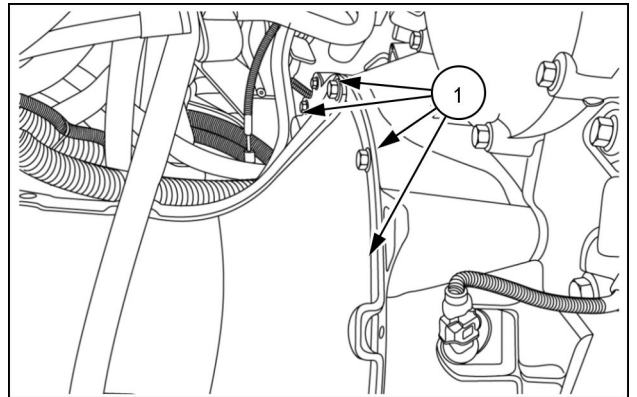

RCPH10CCH813AAB 24

25. Mark the drive shaft (1). Remove the four bolts and disengage the drive shaft from the flywheel.

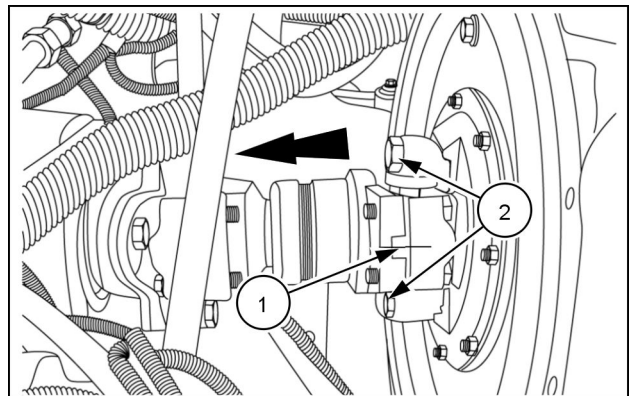

RCPH10CCH817AAB 25

26. Remove the bolts (1) from the plate (2) for the right hand rear engine mount.

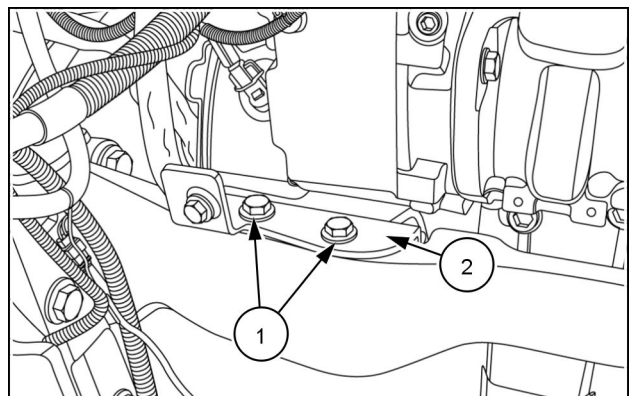

RCPH10CCH925AAB 26

27. Attach appropriately rated lifting equipment to the lifting brackets on the engine. Carefully remove the engine while making certain all harnesses, lines and hoses have been disconnected.

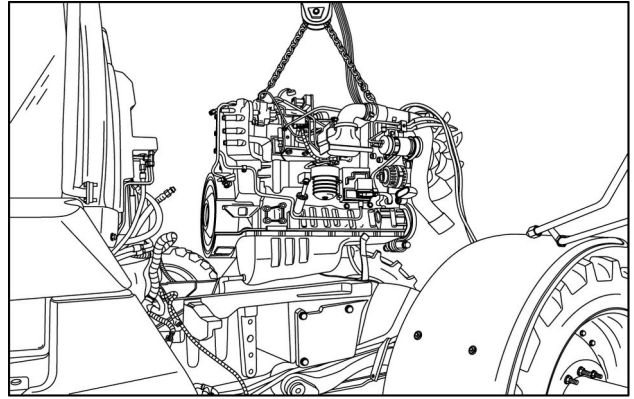

RAIL13TR04247AA 27

28. Remove the right hand rear engine mount. Inspect for wear and/or damage. Replace as required. Repeat for the left hand side.

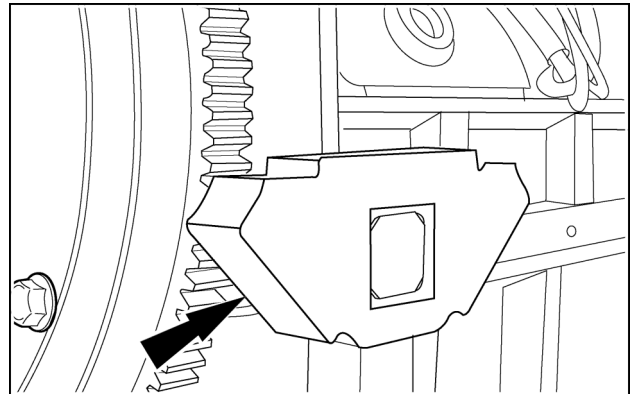

RCPH07CCH166AAB 28

29. Remove the four bolts (1) securing the brackets (2) for the front engine mount.
30. Remove the bolt (3) securing the front engine mount (4).
31. Inspect the mount for wear and/or damage. Replace as required.

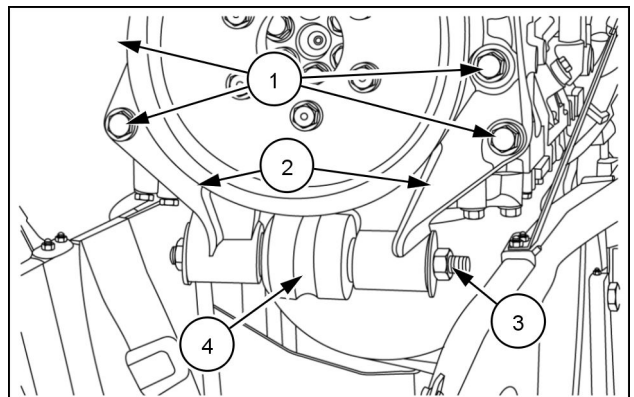

RCPH10CCH833AAB 29

Next operation:
Engine - Install (10.001)

Engine - Install

Prior operation:

Engine - Remove (10.001)

1. If removed, install the front engine mounting brackets (1).
2. Torque the four mounting bolts (2) to **101 - 113 N·m (75 - 83 lb ft)**.
3. Torque the ISO mount support bolt nut (3) to **160 - 220 N·m (118 - 162 lb ft)**.

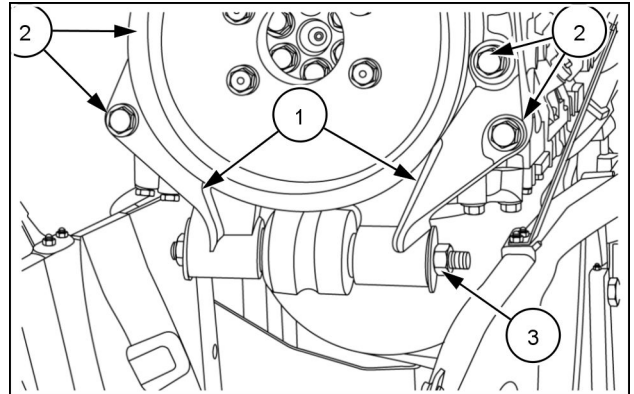

RCPH10CCH833AAB 1

4. Install the right (shown) and left rear engine ISO mounts.

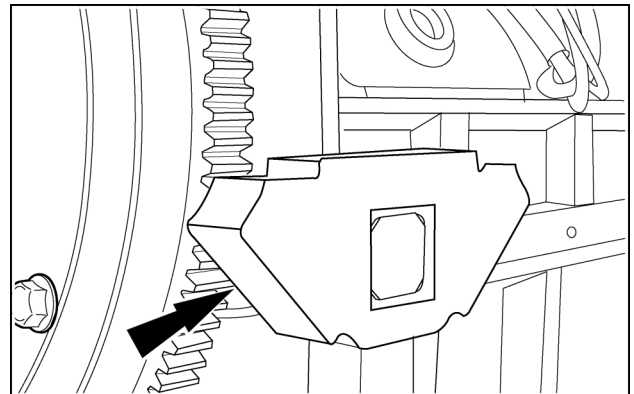

RCPH07CCH166AAB 2

5. Properly support the engine. Raise and move the engine into the front support frame.

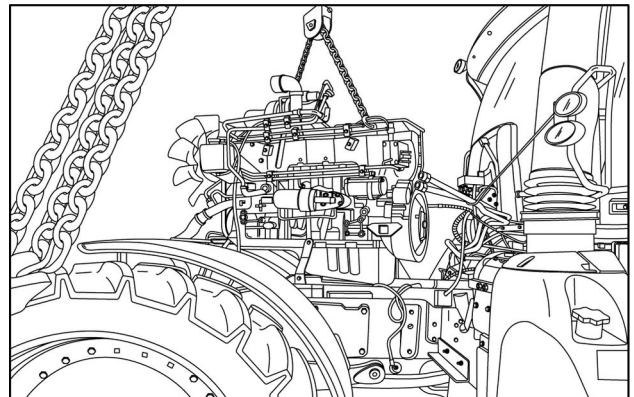

RAIL13TR04248AA 3

6. Install the holding plate (1) for the right rear engine mount with the bolts (2) removed earlier.
7. Torque the bolts to **125 - 150 N·m (92.2 - 110.6 lb ft)**.
8. Install the bolts (3) removed earlier, and torque to **125 - 150 N·m (92 - 111 lb ft)**.
9. Install the hood support bolt and washer (4) and torque to **125 - 150 N·m (92 - 111 lb ft)**.

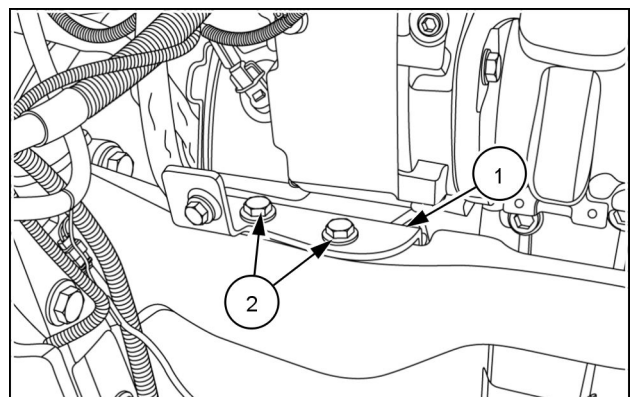

RCPH10CCH925AAB 4

10. Making sure the marks **(1)** are aligned, attach the engine output drive shaft to the engine flywheel.
11. Using the four bolts **(2)** removed earlier to secure the drive shaft to the flywheel.
12. Torque the bolts to **101 - 113 N·m (75 - 83 lb ft)**.

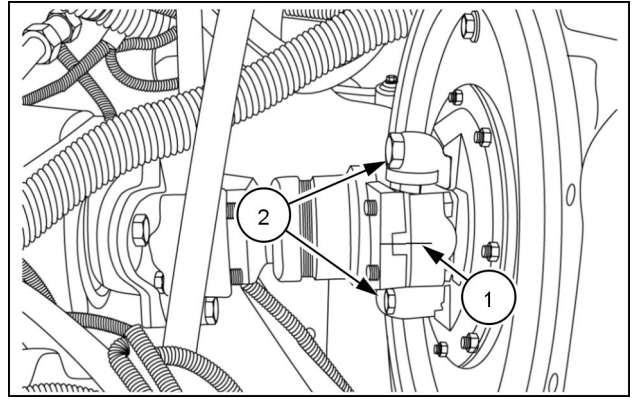

RCPH10CCH817AAB 5

13. Install the engine output drive shaft cover **(1)**. Use the bolts **(2)** removed earlier to secure the cover to the flywheel housing.

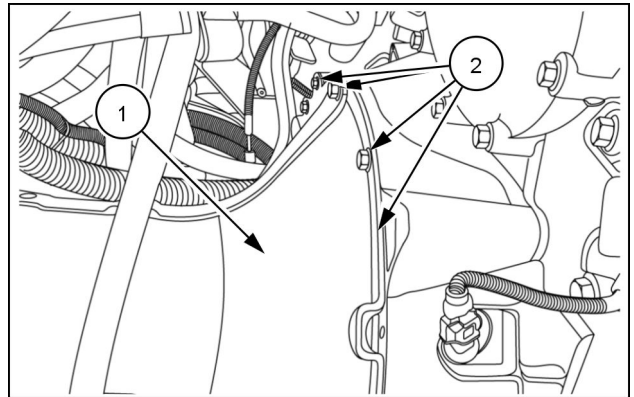

RCPH10CCH813AAB 6

14. Connect the harness connector **(1)** to the engine controller.

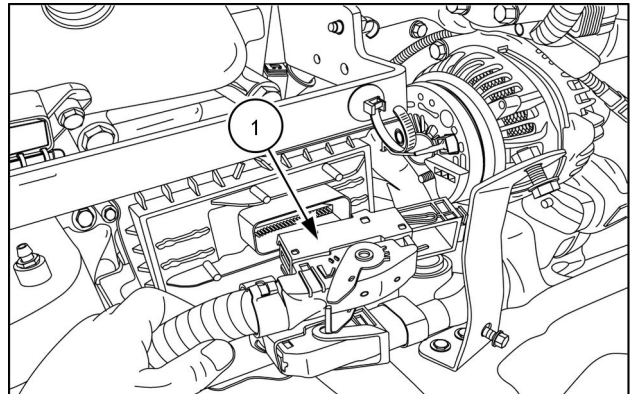

RAIL13TR04226AA 7

15. Connect the alternator output cable **(1)** and secure with the nut removed previously.

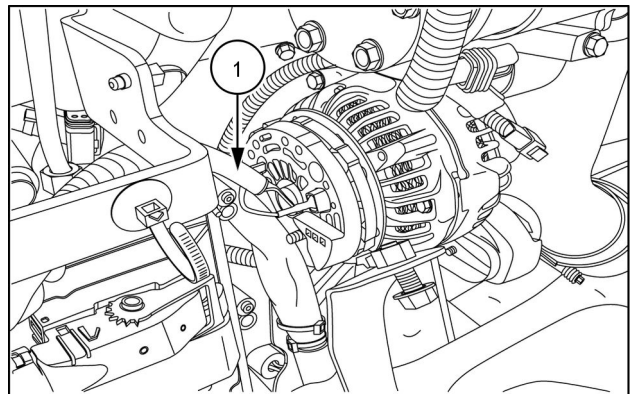

RAIL13TR04231AA 8

16. Connect the alternator excite wire connector (1) and the CAN bus connector (2).

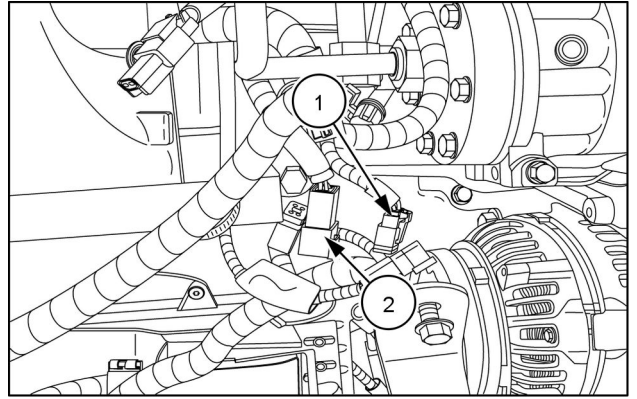

RAIL13TR04221AA 9

17. Connect the harness connector (1) to the A/C pressure switch.

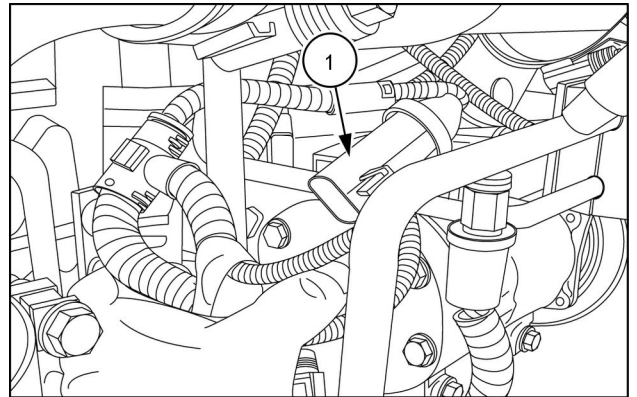

RAIL13TR04223AA 10

18. Connect the ground wire (1) and secure the wire with the A/C compressor mounting bolt (2).

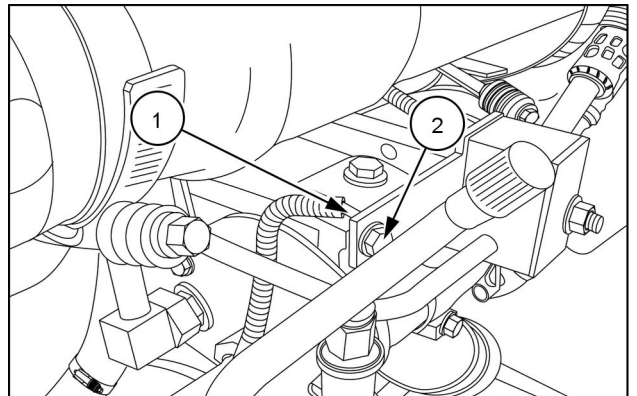

RAIL13TR04224AA 11

19. Connect the harness connector (1) for the fan drive.

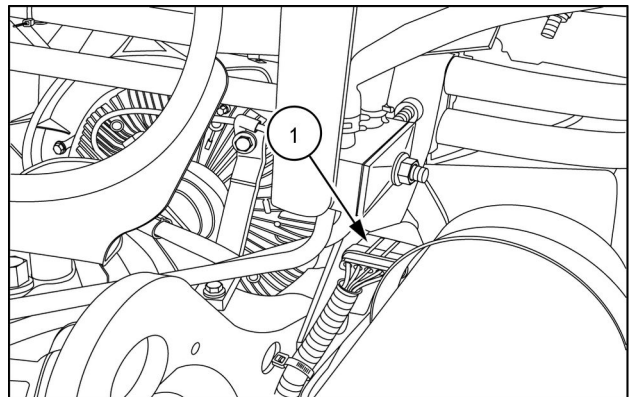

RAIL13TR04220AA 12

20. Connect the vent hose (1) to the intake manifold.

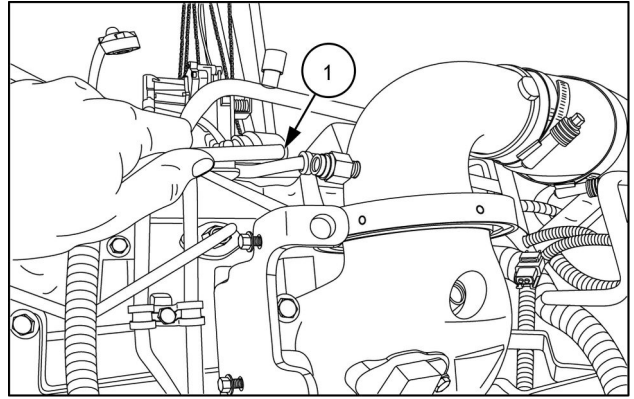

RAIL13TR04218AA 13

21. Connect the harness connector (1) for the engine grid heater and the power supply cable (2).

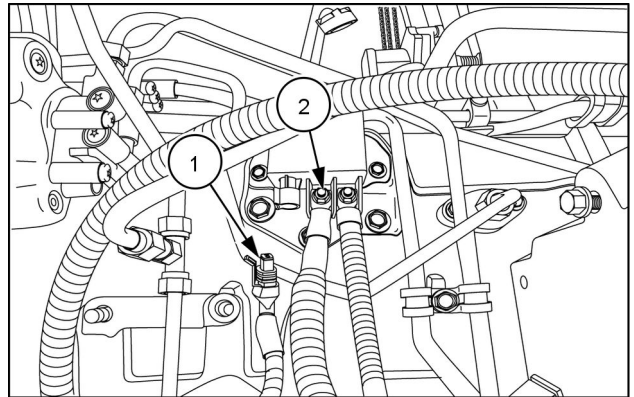

RAIL13TR04219AA 14

22. Install the fuse panel.

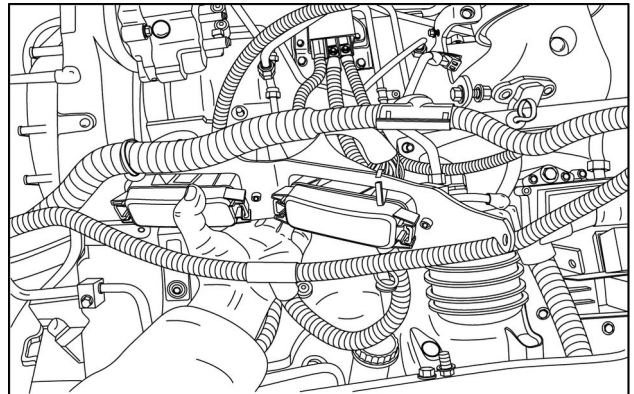

RAIL13TR04214AA 15

23. Secure the fuse panel bracket with the three mounting bolts (1) removed previously. Secure the harness with wire ties.

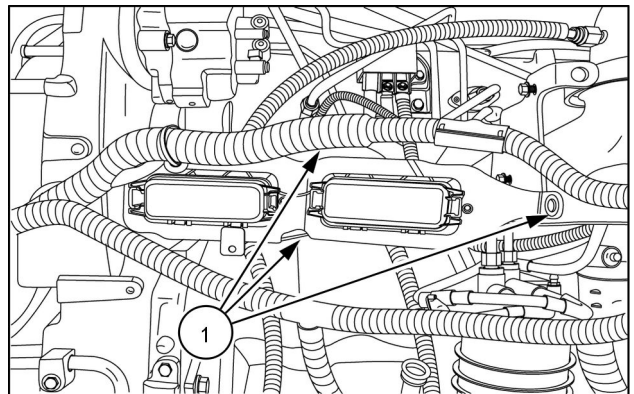

RAIL13TR04216AA 16

24. Connect the oil line (1) and secure with the hose clamp removed previously.

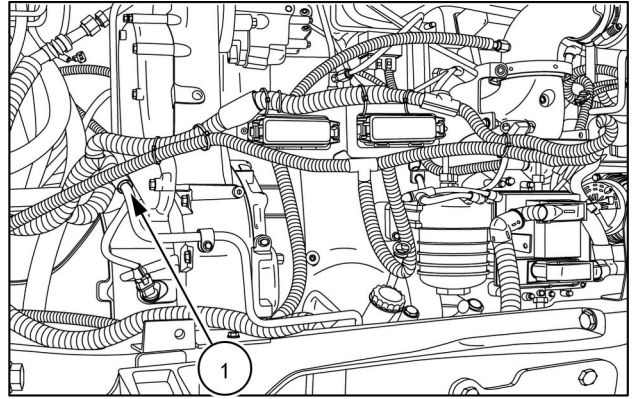

RAIL13TR04213AA 17

25. Lubricate a new O-ring with PAG or mineral oil and install the O-ring. Connect the low pressure A/C line (1).

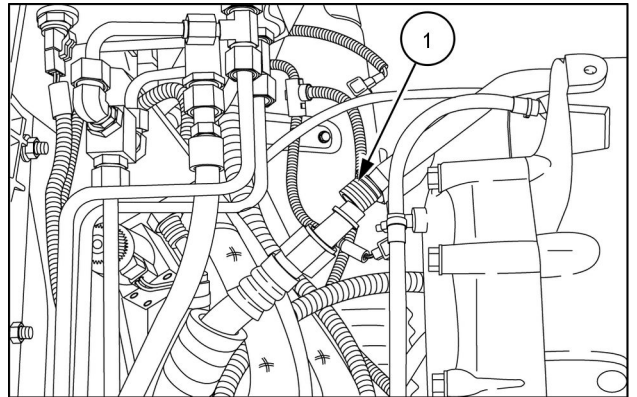

RAIL13TR04228AA 18

26. On the rear of the engine, secure the oil cooler tubes with the tube clamp (1) previously removed.

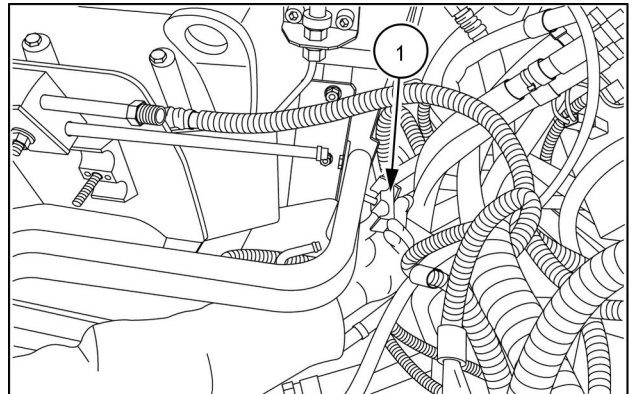

RAIL13TR04236AA 19

27. Connect the front suspended axle electrical connectors (1) if equipped.

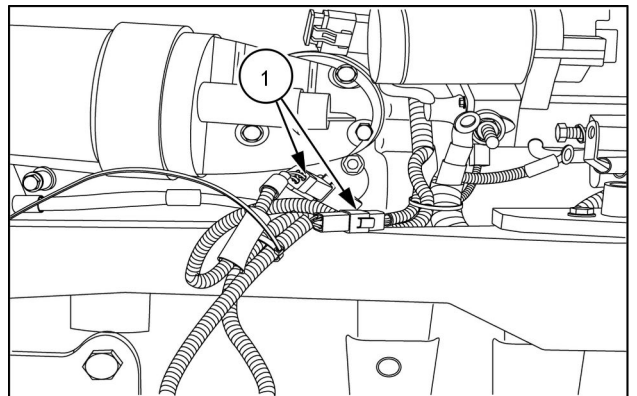

RAIL13TR04237AA 20

28. Install the cover plate for the left hand rear engine mount. Torque the bolts (1) to **125 - 150 N·m (92.2 - 110.6 lb ft)**.

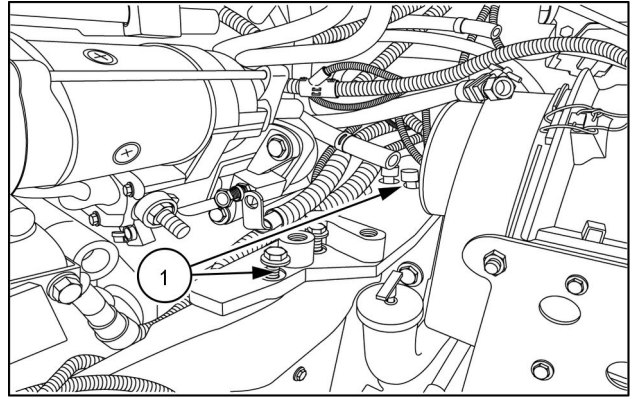

RAIL13TR04243AA 21

29. Lubricate a new O-ring with PAG or mineral oil and install the O-ring; reconnect the high pressure A/C hose (1).
30. Reconnect the coolant lines (2).

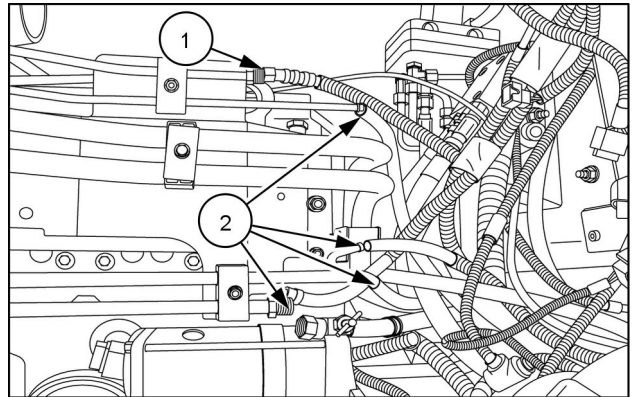

RAIL13TR04230AA 22

31. Install the hood support.

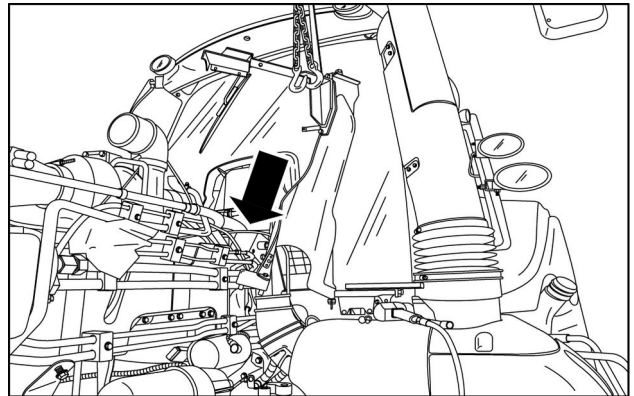

RAIL13TR04212AA 23

32. Torque the bolts (1) to **125 - 150 N·m (92.2 - 110.6 lb ft)**.

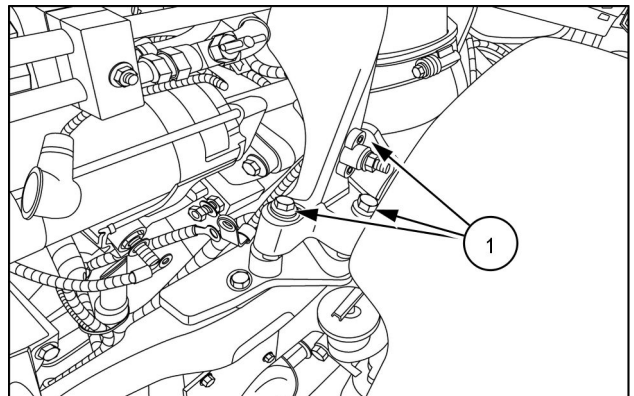

RAIL13TR04209AA 24

33. Connect the starter cables (1) and the auxiliary wire (2).

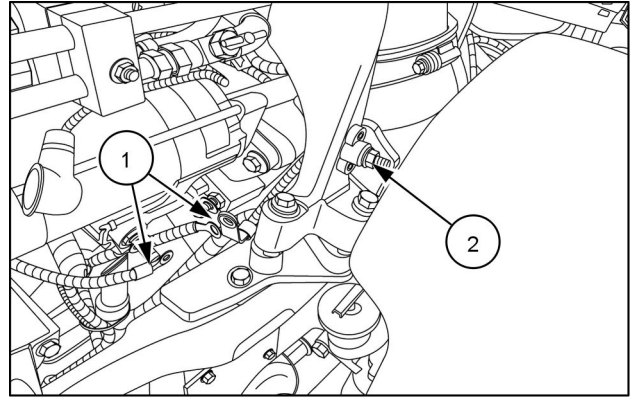

RAIL13TR04209AA 25

34. Install a wire tie (1) to secure the harness to the hood support (2).

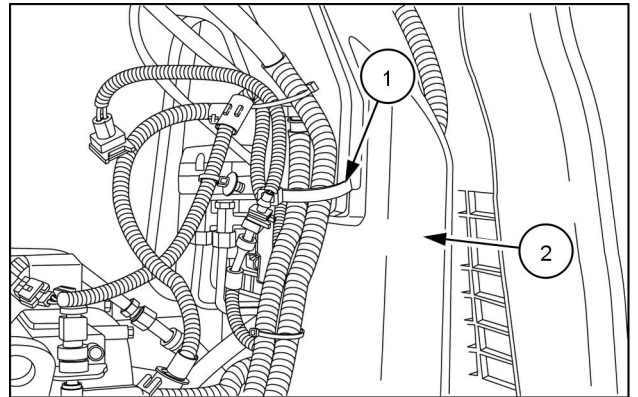

RAIL13TR04204AA 26

35. Install the air intake tube (1) and secure with the hose clamps (2) previously removed.

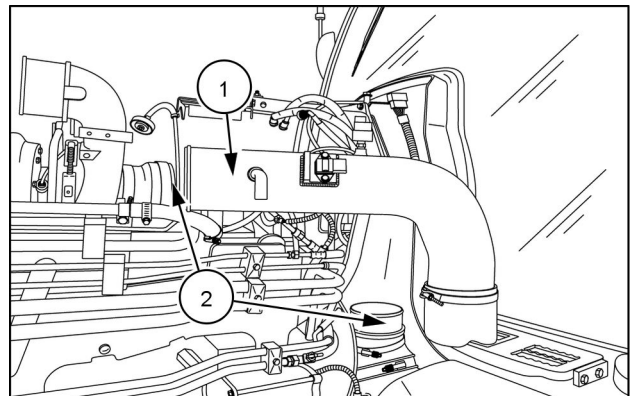

RAIL13TR04211AA 27

36. Connect the harness connectors for the humidity sensor (1) and the air restriction sensor (2). Connect the hose (3) to the air intake tube. Secure the hose with the hose clamp previously removed.

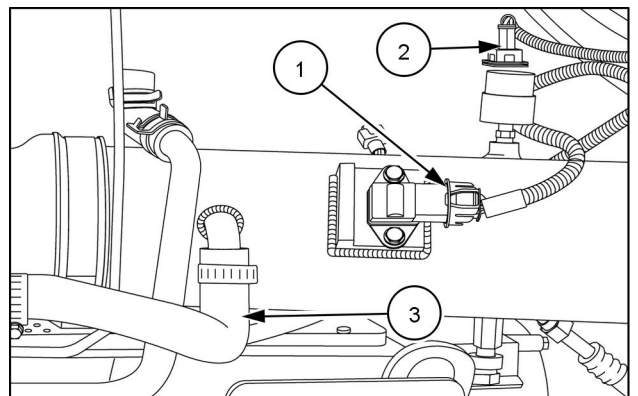

RAIL13TR04202AA 28

Next operation:
Air conditioning - Evacuate (50.200)
Next operation:

Valve cover - Remove - Over head components

Prior operation:

Hood - Remove (90.100)

Prior operation:

Air conditioning - Recover (50.200)

Prior operation:

Engine cooling system - Emptying (10.400)

NOTE: During the disassembly of components with O-ring seals, it is recommended that the seals be discarded and new seal installed during assembly.

NOTE: Cap all fittings and plug all lines/hoses as they are disconnected.

1. Loosen the hose clamp (1) at the air cooler inlet.

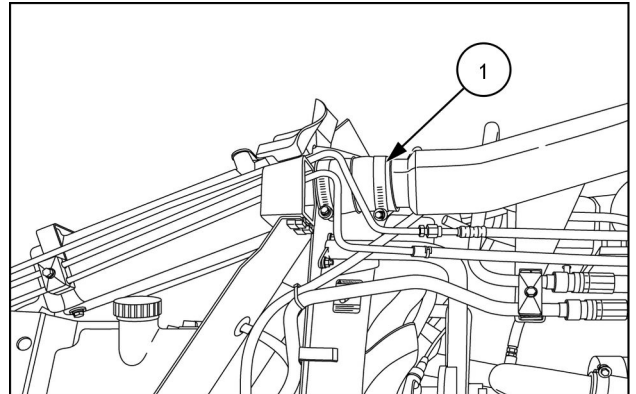

RAIL13TR04527AA 1

2. Loosen the hose clamp (1) on the opposite end of the air cooler inlet and remove the inlet tube.

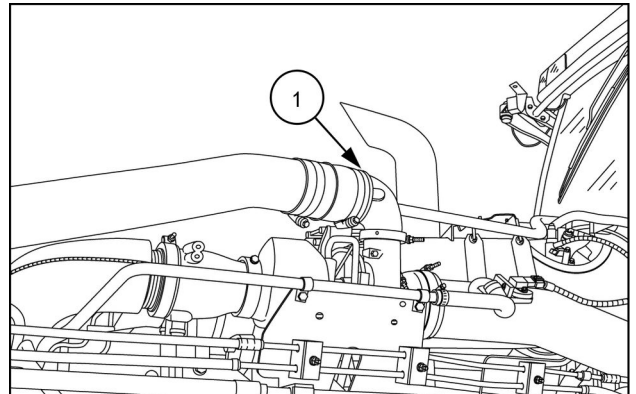

RAIL13TR04526AA 2

3. Remove the oil cooler tube clamp (1).

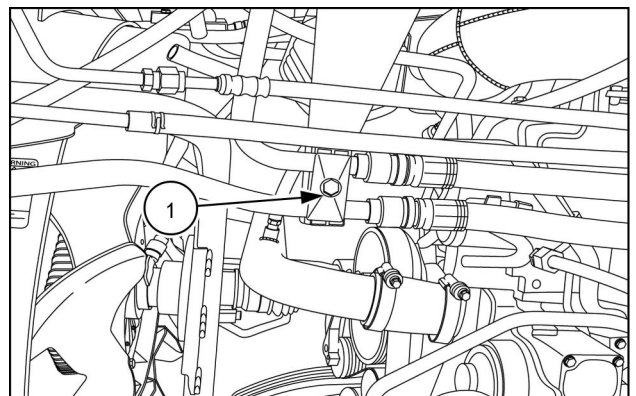

RAIL13TR04534AA 3

4. Disconnect the hydraulic lines (1) using special tool 38000795.

NOTE: Be prepared to collect some hydraulic oil by placing a pan under the fitting.

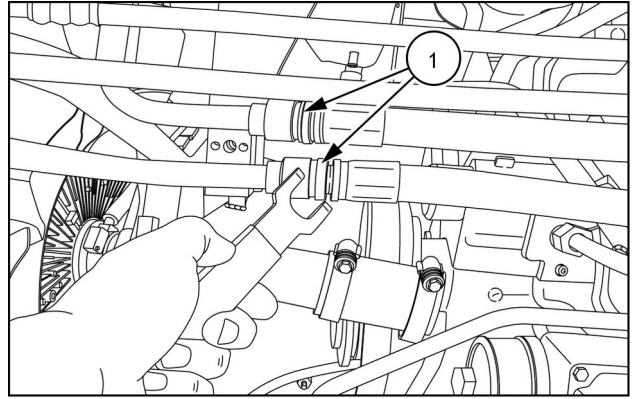

RAIL13TR04535AA 4

5. Disconnect the air conditioning high pressure hose from the tube fitting (1) and the coolant hose (2).

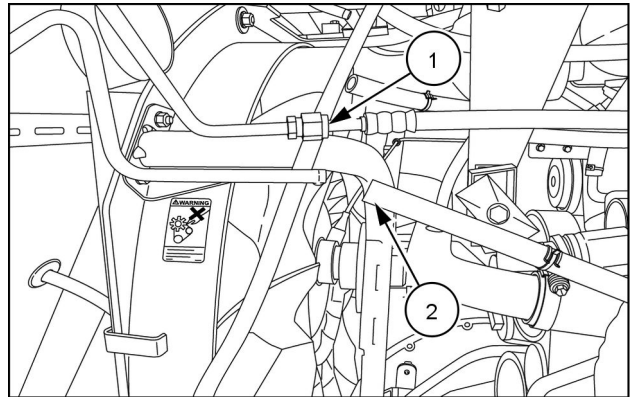

RAIL13TR04537AA 5

6. Remove the hydraulic tube clamp (1) from the hydraulic tube.

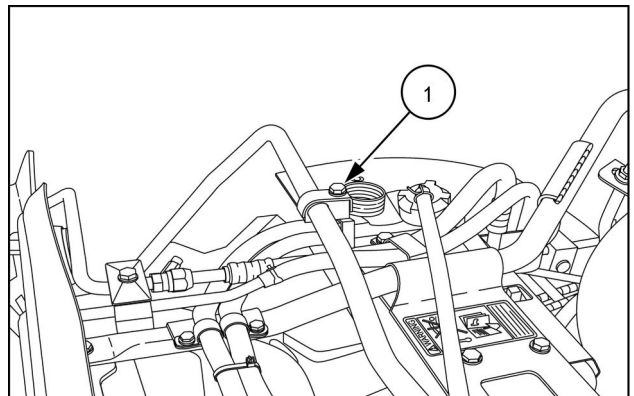

RAIL13TR04536AA 6

7. Remove the hydraulic cooler lines (1) on each side of the cooler (left side shown).

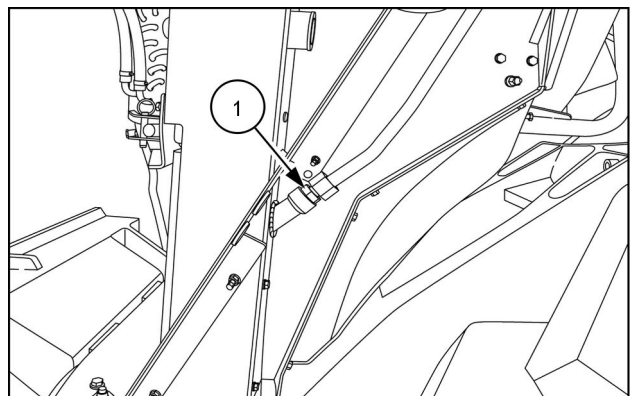

RAIL13TR04530AA 7

8. Disconnect the low pressure A/C line (1), loosen the hose clamps (2) securing the overflow hose.

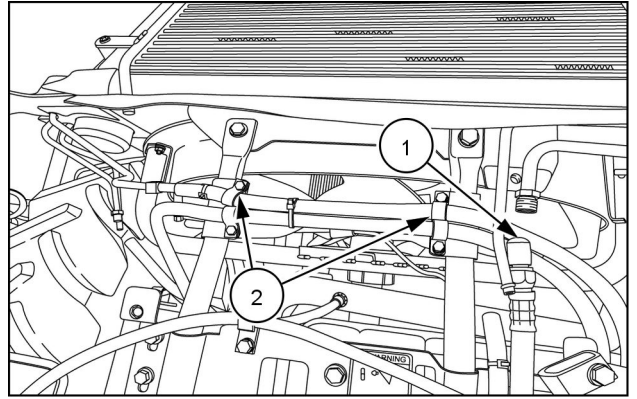

RAIL13TR04542AA 8

9. Disconnect the overflow hose (1) and remove the top bracket mounting bolts (2).

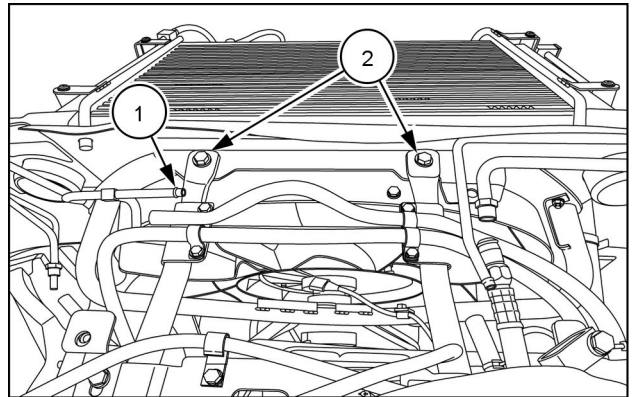

RAIL13TR04543AA 9

10. Remove the two mounting bolts (1) on the rear of the top bracket and remove the bracket.

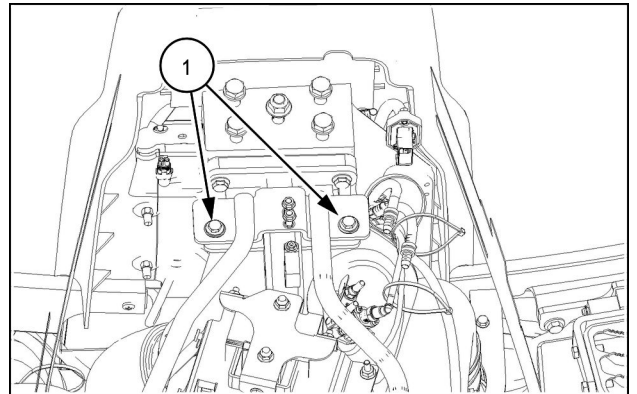

RAIL14TR00391AA 10

11. Disconnect the electrical connector (1), the coolant hoses (2) and the DEF fluid line (3) from the dosing valve.

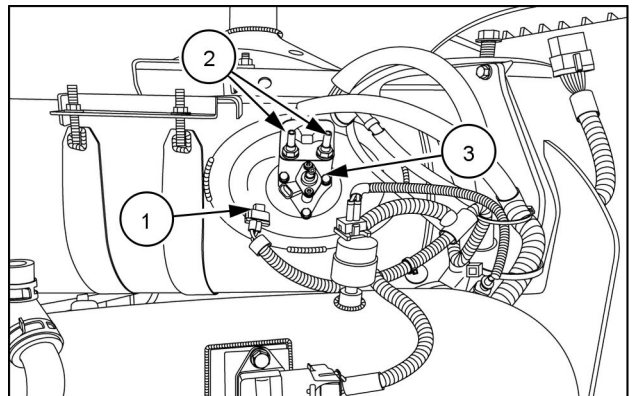

RAIL13TR04188AA 11

12. Remove the NOx sensor (1) from the exhaust pipe.

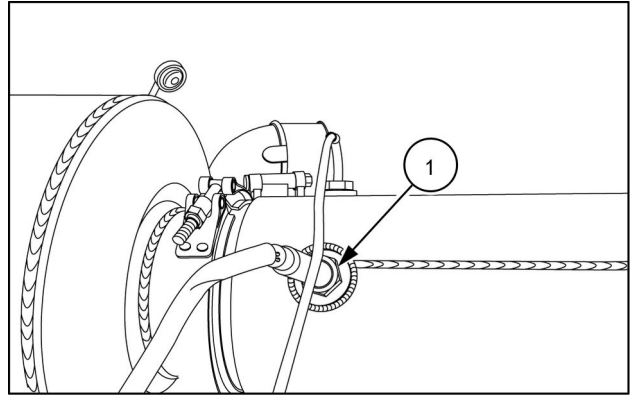

RAIL13TR04185AA 12

13. Disconnect the electrical connector (1) for the temperature sensor.

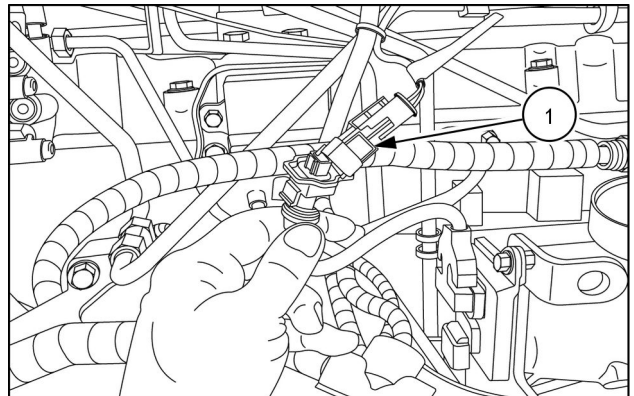

RAIL13TR04183AA 13

14. Disengage the clamp (1) from the exhaust pipe to the turbo.

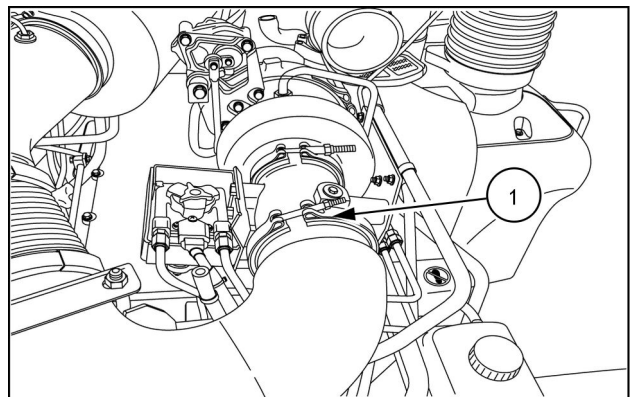

RAIL13TR04177AA 14

15. Disengage the clamp (1) from the exhaust pipe to the Diesel oxidation catalyst (DOC)

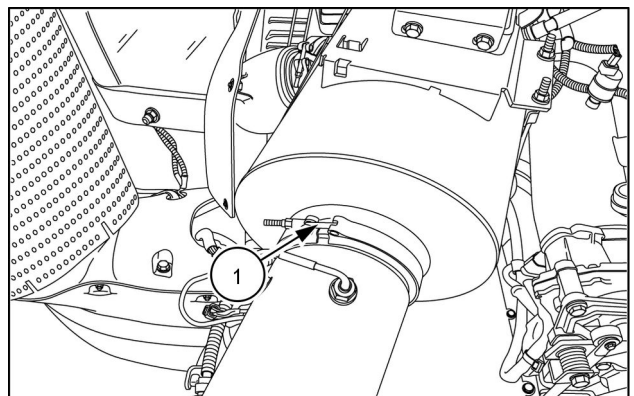

RAIL13TR04180AA 15



Suggest:

If the above button click is invalid.

Please download this document

first, and then click the above link

to download the complete manual.

Thank you so much for reading

16. Remove the two nuts (1) from the C-clamp (2) securing the exhaust pipe. Remove the exhaust pipe and set aside.

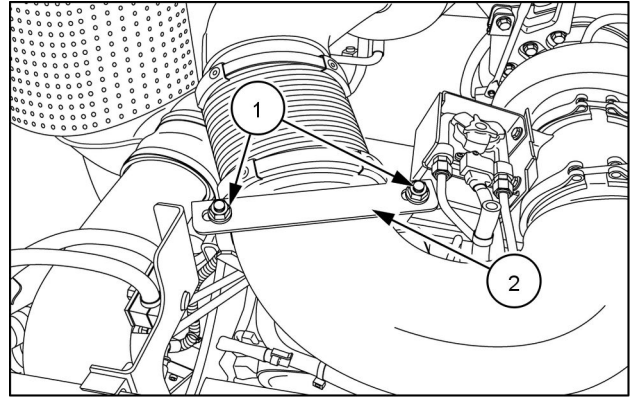

RAIL13TR04181AA 16

17. Disengage the clamp (1) from the outlet side of the catalyst.

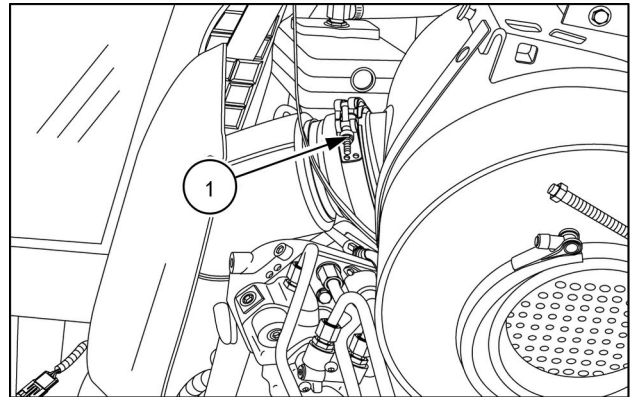

RAIL13TR04192AA 17

18. Remove the two nuts (1) from the catalyst mounting straps.

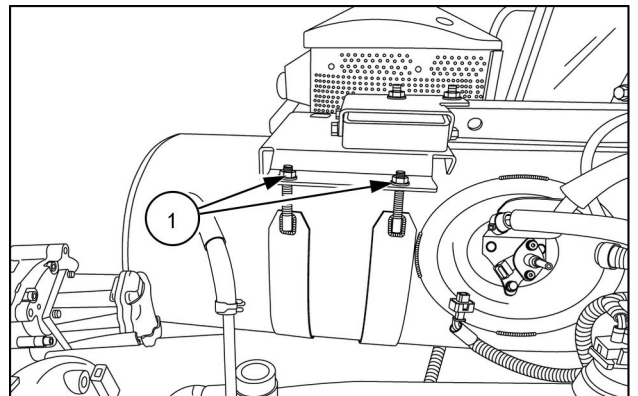

RAIL13TR04190AA 18

19. Slide the catalyst forward from under the support bracket. Remove the catalyst.

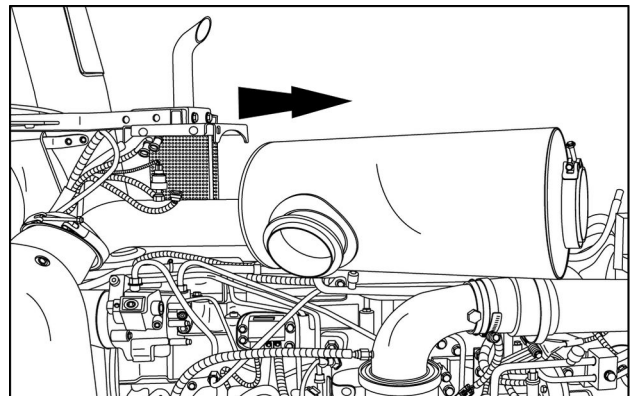

RAIL13TR04193AA 19

Next operation:
Remove the valve cover.
Next operation:

<https://www.ebooklibonline.com>

Hello dear friend!

Thank you very much for reading.

Enter the link into your browser.

The full manual is available for immediate download.

<https://www.ebooklibonline.com>