

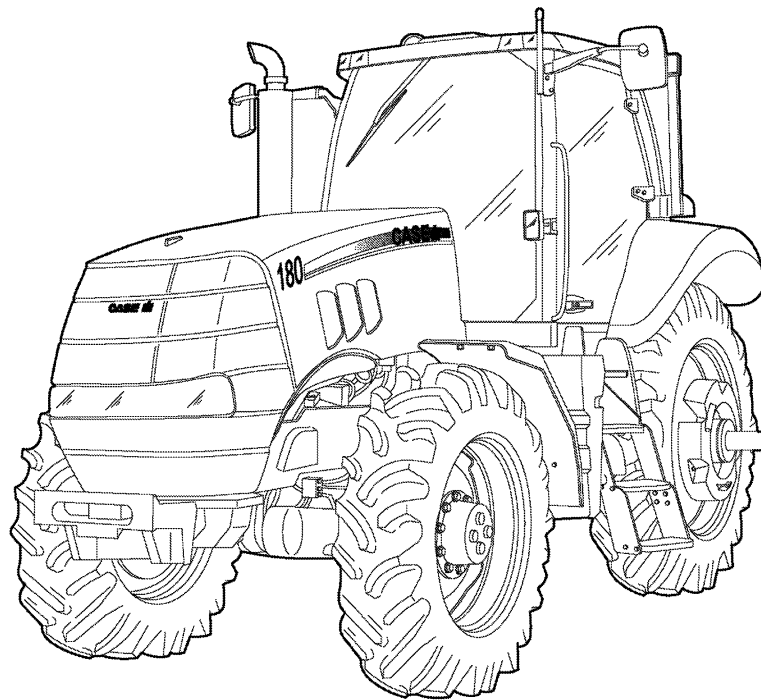

SERVICE MANUAL



Magnum 180
Magnum 190
Magnum 210
Magnum 225 [Z9RH06000 -]

Contents

INTRODUCTION

DISTRIBUTION SYSTEMS..... A

PRIMARY HYDRAULIC POWER SYSTEM A.10.A

PRIMARY HYDRAULIC POWER SYSTEM Electro-hydraulic remote valve A.10.C

ELECTRICAL POWER SYSTEM A.30.A

ELECTRONIC SYSTEM A.50.A

FAULT CODES A.50.A

POWER PRODUCTION B

ENGINE B.10.A

FUEL AND INJECTION SYSTEM..... B.20.A

AIR INTAKE SYSTEM..... B.30.A

ENGINE COOLANT SYSTEM B.50.A

LUBRICATION SYSTEM B.60.A

POWER TRAIN C

POWER COUPLING Fixed coupling C.10.B

POWER COUPLING Drop box..... C.10.E

ADDITIONAL REDUCERS Creeper..... C.30.C

REAR PTO Hydraulic..... C.40.C

BAR AXLE..... C.60.A

TRANSMISSION Continuously Variable Transmission (CVT) C.20.G

TRAVELLING D

FRONT AXLE D.10.A

2WD-4WD SYSTEM Hydraulic..... D.14.C

STEERING Hydraulic..... D.20.C

SERVICE BRAKE Hydraulic..... D.30.C

PARKING BRAKE Electronic..... D.32.D

BRAKE CONNECTION Hydraulic..... D.34.C

BODY AND STRUCTURE E

SHIELD	E.20.A
USER CONTROLS AND SEAT	E.32.A
USER CONTROLS AND SEAT Operator seat	E.32.C
USER PLATFORM	E.34.A
ENVIRONMENT CONTROL Heating, ventilation and air-conditioning.....	E.40.D
FRAME POSITIONING	F
STABILISING Ballasting.....	F.20.B
WORKING ARM.....	H
HITCH Rear hitch.....	H.10.C

<https://www.ebooklibonline.com>

Hello dear friend!

Thank you very much for reading.

Enter the link into your browser.

The full manual is available for immediate download.

<https://www.ebooklibonline.com>



INTRODUCTION

Torque

Magnum 180, Magnum 190, Magnum 210

Decimal hardware

Grade 5 bolts, nuts and studs

Size	Nm	lb in/lb ft
1/4 in	12 - 15 Nm	108 - 132 lb in
5/16 in	23 - 28 Nm	204 - 252 lb in
3/8 in	48 - 57 Nm	420 - 504 lb in
7/16 in	73 - 87 Nm	54 - 64 lb ft
1/2 in	109 - 130 Nm	80 - 96 lb ft
9/16 in	149 - 179 Nm	110 - 132 lb ft
5/8 in	203 - 244 Nm	150 - 180 lb ft
3/4 in	366 - 439 Nm	270 - 324 lb ft
7/8 in	542 - 651 Nm	400 - 480 lb ft
1 in	787 - 944 Nm	580 - 696 lb ft
1-1/8 in	1085 - 1193 Nm	800 - 880 lb ft
1-1/4 in	1519 - 1681 Nm	1120 - 1240 lb ft
1-3/8 in	1980 - 2278 Nm	1460 - 1680 lb ft
1-1/2 in	2631 - 2983 Nm	1940 - 2200 lb ft

Grade 8 bolts, nuts and studs

Size	Nm	lb in/lb ft
1/4 in	16 - 20 Nm	144 - 180 lb in
5/16 in	33 - 39 Nm	288 - 348 lb in
3/8 in	61 - 73 Nm	540 - 648 lb in
7/16 in	95 - 114 Nm	70 - 84 lb ft
1/2 in	149 - 179 Nm	110 - 132 lb ft
9/16 in	217 - 260 Nm	160 - 192 lb ft
5/8 in	298 - 358 Nm	220 - 264 lb ft
3/4 in	515 - 618 Nm	380 - 456 lb ft
7/8 in	814 - 976 Nm	600 - 720 lb ft
1 in	1220 - 1465 Nm	900 - 1080 lb ft
1-1/8 in	1736 - 1953 Nm	1280 - 1440 lb ft
1-1/4 in	2468 - 2712 Nm	1820 - 2000 lb ft
1-3/8 in	3227 - 3688 Nm	2380 - 2720 lb ft
1-1/2 in	4285 - 4827 Nm	3160 - 3560 lb ft

NOTE: Use thick nuts with Grade 8 bolts.

Metric hardware

Grade 8.8 bolts, nuts and studs

Size	Nm	lb in/lb ft
4 mm	3 - 4 Nm	24 - 36 lb in
5 mm	7 - 8 Nm	60 - 72 lb in
6 mm	11 - 12 Nm	96 - 108 lb in
8 mm	26 - 31 Nm	228 - 276 lb in
10 mm	52 - 61 Nm	456 - 540 lb in
12 mm	90 - 107 Nm	66 - 79 lb ft
14 mm	144 - 172 Nm	106 - 127 lb ft
16 mm	217 - 271 Nm	160 - 200 lb ft
20 mm	434 - 515 Nm	320 - 380 lb ft
24 mm	675 - 815 Nm	500 - 600 lb ft
30 mm	1250 - 1500 Nm	920 - 1100 lb ft
36 mm	2175 - 2600 Nm	1600 - 1950 lb ft

INTRODUCTION

Grade 10.9 bolts, nuts and studs

Size	Nm	lb in/lb ft
4 mm	4 - 5 Nm	36 - 48 lb in
5 mm	9 - 11 Nm	84 - 96 lb in
6 mm	15 - 18 Nm	132 - 156 lb in
8 mm	37 - 43 Nm	324 - 384 lb in
10 mm	73 - 87 Nm	54 - 64 lb ft
12 mm	125 - 150 Nm	93 - 112 lb ft
14 mm	200 - 245 Nm	149 - 179 lb ft
16 mm	310 - 380 Nm	230 - 280 lb ft
20 mm	610 - 730 Nm	450 - 540 lb ft
24 mm	1050 - 1275 Nm	780 - 940 lb ft
30 mm	2000 - 2400 Nm	1470 - 1770 lb ft
36 mm	3500 - 4200 Nm	2580 - 3090 lb ft

Grade 12.9 bolts, nuts and studs

Size	Nm	lb in/lb ft
Typically the torque values specified for grade 10.9 hardware can be used satisfactorily on grade 12.9 hardware.		

Steel hydraulic fittings

37° flare fitting

Tube outside diameter/Hose inside diameter		Thread size	Nm	lb in/lb ft
inch	mm			
6.4 mm	1/4 in	7/16-20 in	8 - 16 Nm	72 - 144 lb in
7.9 mm	5/16 in	1/2-20 in	11 - 22 Nm	96 - 192 lb in
9.5 mm	3/8 in	9/16-18 in	14 - 34 Nm	120 - 300 lb in
12.7 mm	1/2 in	3/4-16 in	20 - 57 Nm	180 - 504 lb in
15.9 mm	5/6 in	7/8-14 in	34 - 79 Nm	300 - 696 lb in
19.0 mm	3/4 in	1-1/16-12 in	54 - 108 Nm	40 - 80 lb ft
22.2 mm	7/8 in	1-3/16-12 in	81 - 135 Nm	60 - 100 lb ft
25.4 mm	1 in	1-5/16-12 in	102 - 158 Nm	75 - 117 lb ft
31.8 mm	1-1/4 in	1-5/8-12 in	169 - 223 Nm	125 - 165 lb ft
38.1 mm	1-1/2 in	1-7/8-12 in	285 - 338 Nm	210 - 250 lb ft

Straight threads with O-ring

Tube outside diameter/Hose inside diameter		Thread size	Nm	lb in/lb ft
inch	mm			
6.4 mm	1/4 in	7/16-20 in	16 - 26 Nm	144 - 228 lb in
7.9 mm	5/16 in	1/2-20 in	22 - 34 Nm	192 - 300 lb in
9.5 mm	3/8 in	9/16-18 in	34 - 54 Nm	300 - 480 lb in
12.7 mm	1/2 in	3/4-16 in	57 - 91 Nm	540 - 804 lb in
15.9 mm	5/6 in	7/8-14 in	79 - 124 Nm	58 - 92 lb ft
19.0 mm	3/4 in	1-1/16-12 in	108 - 174 Nm	80 - 128 lb ft
22.2 mm	7/8 in	1-3/16-12 in	136 - 216 Nm	100 - 160 lb ft
25.4 mm	1 in	1-5/16-12 in	159 - 253 Nm	117 - 187 lb ft
31.8 mm	1-1/4 in	1-5/8-12 in	224 - 357 Nm	165 - 264 lb ft
38.1 mm	1-1/2 in	1-7/8-12 in	339 - 542 Nm	250 - 400 lb ft

Split flange mounting bolts

Size	Nm	lb in/lb ft
5/16-18 in	20 - 27 Nm	180 - 240 lb in
3/8-16 in	27 - 34 Nm	240 - 300 lb in
7/16-14 in	47 - 61 Nm	420 - 540 lb in
1/2-13 in	74 - 88 Nm	55 - 65 lb ft
5/8-11 in	190 - 203 Nm	140 - 150 lb ft

INTRODUCTION

Nominal SAE dash size	O-ring face seal end		O-ring boss end fitting or lock nut					
	Tube outside diameter mm	in	Thread size	Nm	lb in/lb ft	Thread size	Nm	lb in/lb ft
-4	6.4 mm	1/4 in	9/16-18 in	14 - 16 Nm	120 - 144 lb in	7/16-20 in	23 - 27 Nm	204 - 240 lb in
-6	9.5 mm	3/8 in	11/16-16 in	24 - 27 Nm	216 - 240 lb in	9/16-18 in	34 - 41 Nm	300 - 360 lb in
-8	12.7 mm	1/2 in	13/16-16 in	43 - 54 Nm	384 - 480 lb in	3/4-16 in	61 - 68 Nm	540 - 600 lb in
-10	15.9 mm	5/8 in	1-14 in	62 - 76 Nm	552 - 672 lb in	7/8-14 in	81 - 88 Nm	60 - 65 lb ft
-12	19.0 mm	3/4 in	1-3/16-12 in	90 - 110 Nm	65 - 80 lb ft	1-1/16-12 in	115 - 122 Nm	85 - 90 lb ft
-14	22.2 mm	7/8 in	1-3/16-12 in	90 - 110 Nm	65 - 80 lb ft	1-13/16-12 in	129 - 136 Nm	95 - 100 lb ft
-16	25.41 mm	1.0 in	1-7/16-12 in	125 - 140 Nm	92 - 105 lb ft	1-5/16-12 in	156 - 169 Nm	115 - 125 lb ft
-20	31.8 mm	1-1/4 in	1-11/16-12 in	170 - 190 Nm	125 - 140 lb ft	1-5/6-12 in	201 - 217 Nm	150 - 160 lb ft
-24	38.1 mm	1-1/2 in	2-12 in	200 - 254 Nm	150 - 180 lb ft	1-7/8-12 in	258 - 271 Nm	190 - 200 lb ft

Capacities

Magnum 180, Magnum 190, Magnum 210

Magnum 180, 190, 210 and 225

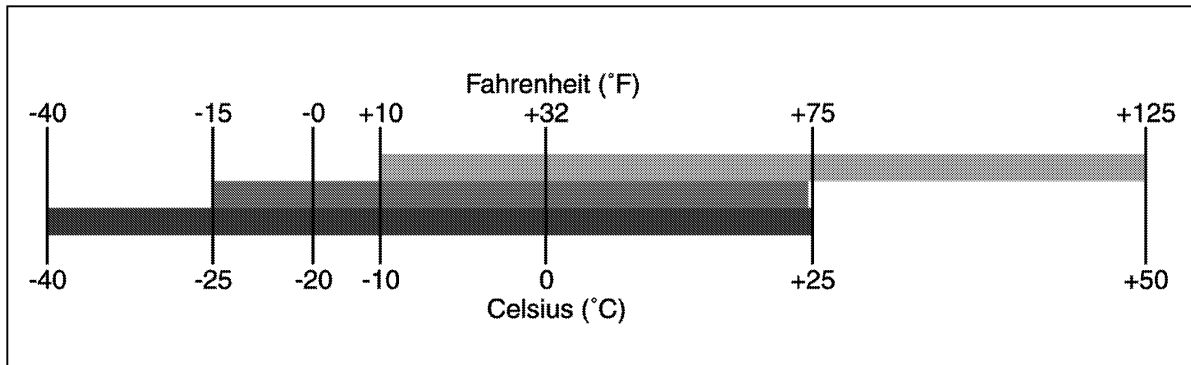

System	Metric	U.S.	Imperial
Engine Oil			
No filter change	16 l	4.23 US gal	3.52 UK gal
With filter change	16.5 l	4.36 US gal	3.63 UK gal
Cooling system	23.65 l	6.25 US gal	5.2 UK gal
Transmission/hydraulic system			
Full Powershift	85 l	22.5 US gal	18.7 UK gal
CVT	100 l	26.4 US gal	22.0 UK gal
Mechanical front drive (MFD)			
4 pin – 10 bolt axle*			
Differential	12.3 l	13 US qt	21.6 UK pt
Planetary (each)	1.4 l	3 US pt	2.4 UK pt
4 pin – 12 bolt axle*			
Differential	11 l	11.6 US qt	21.6 UK pt
Planetary (each)	2.3 l	2.4 US qt	2.0 UK qt
Fuel tank	446 l	118 US gal	98.25 UK gal

* Pin and bolt quantity are determined by observing the wheel ends.



RCIL08CCH001EAA 1

Axle oil viscosity/temperature usage recommendation

-  CASE AKCELA 135H EP GEAR LUBE SAE 85W-140
-  CASE AKCELA 135H EP GEAR LUBE SAE 80W-90
-  CASE AKCELA GEAR LUBE SSL (75W-90)



SERVICE MANUAL

DISTRIBUTION SYSTEMS

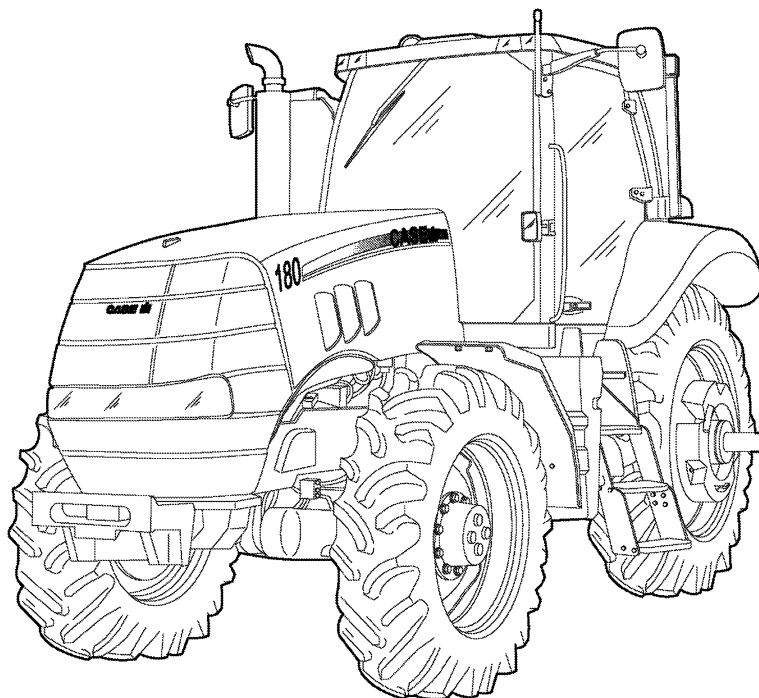

**Magnum 180
Magnum 190
Magnum 210
Magnum 225 [Z9RH06000 -]**

PRIMARY HYDRAULIC POWER SYSTEM - Dynamic description

Magnum 225 [Z9RH06000 -] CVT Transmission, Magnum 180 [Z9RH06000 -] CVT Transmission, Magnum 190 [Z9RH06000 -] CVT Transmission, Magnum 210 [Z9RH06000 -] CVT Transmission

The tractor is equipped with three hydraulic pumps, a pressure and flow compensated (PFC) piston pump, charge pump and a vane pump. All three pumps are driven through a drive housing on the right side of the transmission. The pump drive housing gears are driven by the PTO drive line. All three pumps turn at approximately 1.25 times engine speed.

The pressure and flow compensated (PFC) piston pump is attached and driven by the rear pump drive. The system charge pump is mounted directly onto the back of the PFC pump. All flow from the charge pump passes through the charge filter assembly and a portion passes through the oil cooler before delivery to the PFC pump inlet.

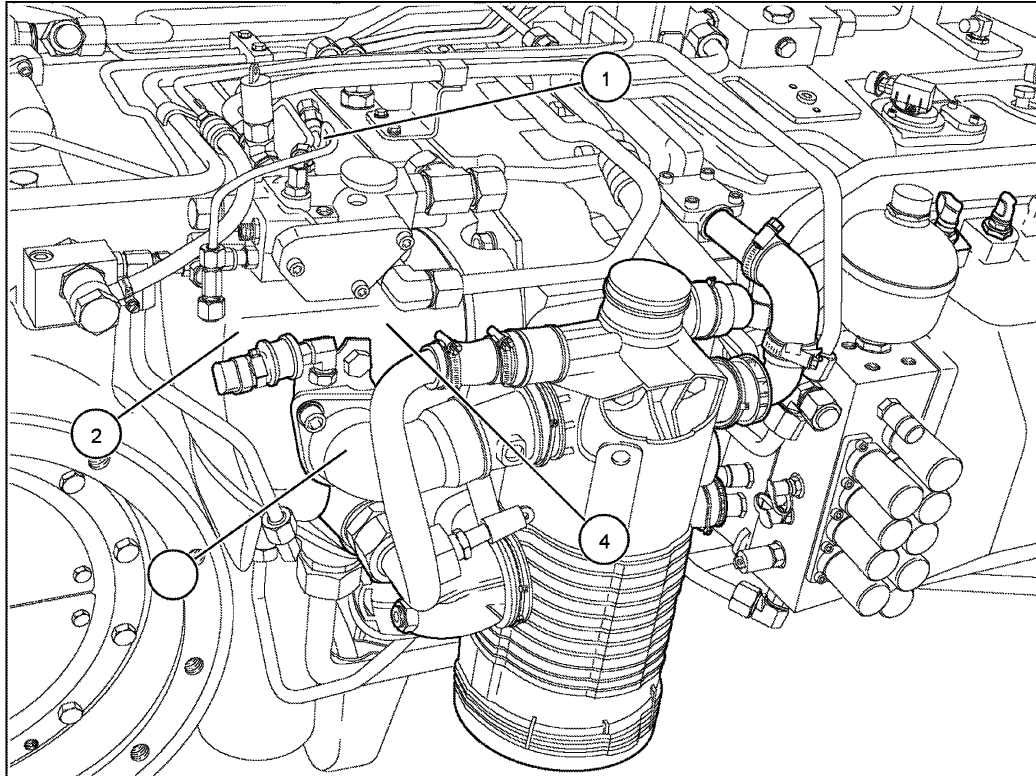

RCPH09CCH025FAE 1

1. PFC pump compensator	3. Charge pump inlet
2. Charge pump	4. PFC pump

Pressure and flow compensated pump

The pressure and flow compensated (PFC) piston pump has variable flow output and operates at variable pressures. The pump matches hydraulic power output to the actual load requirements to ensure maximum efficiency and minimum fuel usage.

The PFC pump output is supplied directly to a flange mounted priority valve. The priority valve supplies the steering system first, the trailer brakes receive second priority (if equipped).

NOTE: The optional trailer brake valve, if equipped, mounts directly on the priority valve. Hydraulic trailer brakes receive second priority from PFC piston pump.

Once steering and trailer brakes are satisfied, the PFC piston pump supplies the following circuits:

- Remote valves
- Hitch valve
- Mid mount valves

- Suspended axle control valve

Charge Pump

The gerotor type charge pump is mounted on and driven by the PFC piston pump. The charge pump draws oil directly from main filter housing. The charge pump housing is equipped with a filter assembly. All charge pump flow passes through the charge filter assembly and a portion passes through the oil cooler before delivery to the PFC pump inlet. Any excess charge flow is routed to the main filter assembly and is available to the lube circuit. The charge pressure is limited to **1000 kPa (145 psi)** by the charge relief.

Vane Pump (regulated circuit)

The vane pump is driven off the front of the pump drive assembly. The pump inlet is directly supplied from the main filter assembly. At start up the vane pump stator ring is held in full demand position by the stroking piston spring. This ensures that pumping will begin at start up. The vane pump control valve is also held in full demand position by the pressure control spring.

At start up charge pump pressure increases and is routed to the back side of the vanes forcing them outwards. Oil enters the pumping chambers from the suction gallery, as the rotating group turns the pumping volume decreases and exits the pressure "P" port. From the main output of the vane pump the flow is delivered through the vane pump filter assembly to the low pressure circuits:

The following circuits are supplied by the regulated pressure circuit:

- Front wheel drive (MFD) solenoid valve
- Differential lock valve solenoid
- PTO and PTO brake solenoids
- Remote valve pilot supply
- Mid mount valves pilot supply (if equipped)
- Transmission control valve
- Service brakes and brake booster accumulator
- CVT hydro pilot supply

The vane pump low pressure system is limited to **2200 - 2500 kPa (320 - 362 psi)** by the vane pump regulator assembly. At this regulated pressure the vane pump flow is also destroyed. The vane pump system is limited to **2800 kPa (406 psi)** by the regulated circuit relief valve.

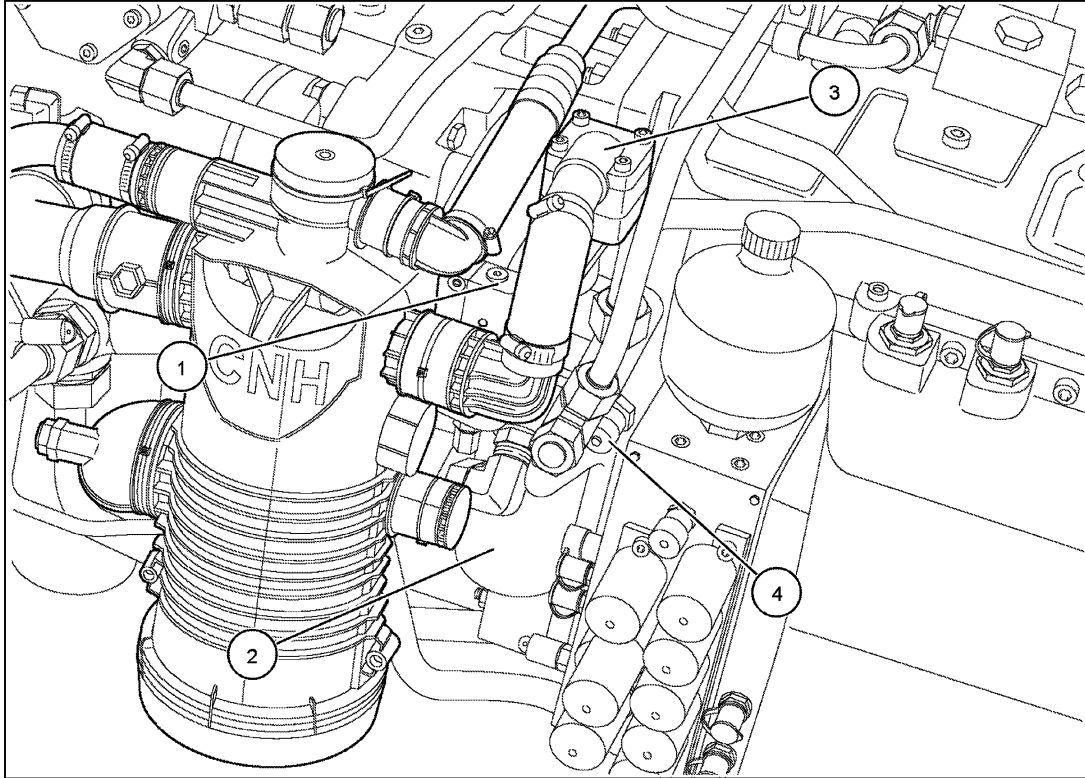

RCPH09CCH035FAE 2

1. Vane pump	3. Vane pump inlet
2. Vane pump filter	4. Vane pump test port

Priority valve

The priority valve is located on top, right side of the transmission housing. The valve is flange mounted directly onto the PFC piston pump outlet port.

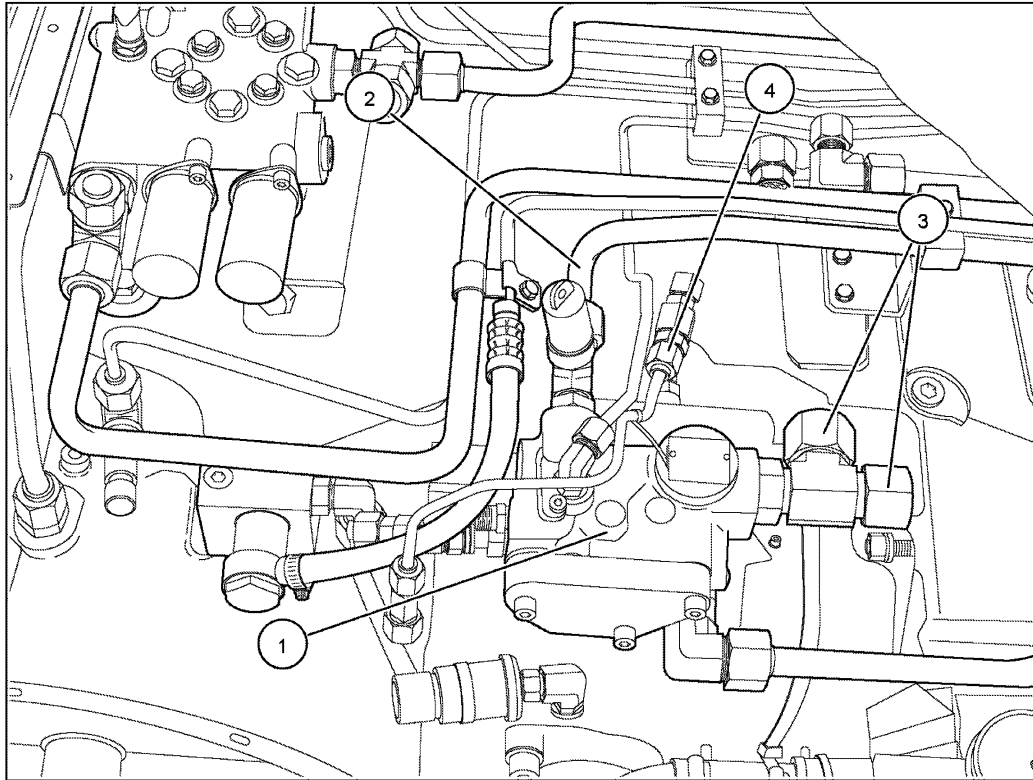

RCPH09CCH031FAE 3

1. Priority valve	3. Supply to PFC high pressure circuits
2. Steering supply tube assembly	4. Load sense line

The trailer brake valve, if equipped, is flange mounted to the priority valve. Trailer brake circuit receives second priority to steering circuit.

Principle of control for PFC pump

All remote valves, the hitch control valve, the optional trailer brake, optional mid mount valve(s) and optional power beyond circuit contain a signal port. Each signal port directs signal pressure, equal to the working pressure of that circuit, through signal lines and check valves to the pump compensator spool. The compensator angles the pump swash plate to meet system demands.

A check valve is located in each signal line between the control valves and the compensator spool. If several control valves are operated at the same time, the signal line at the highest pressure causes the other check valve(s) at the lower pressures to seat themselves. This prevents signal bleed off through other control valves and ensures that the highest signal pressure acts on the compensator spool.

The pump is designed to operate in two different modes according to the demand for flow and pressure. The modes are:

- Low pressure standby – when there is no demand for flow or pressure, the pump provides just enough flow to make up for internal leakage in the hydraulic system at low pressure. In this mode the pump requires very little power to drive it.
- Pressure/flow delivery and compensation – when there is a demand for flow and pressure from the hydraulic system, the pump responds to provide only the flow required. This limits the power consumption of the system.

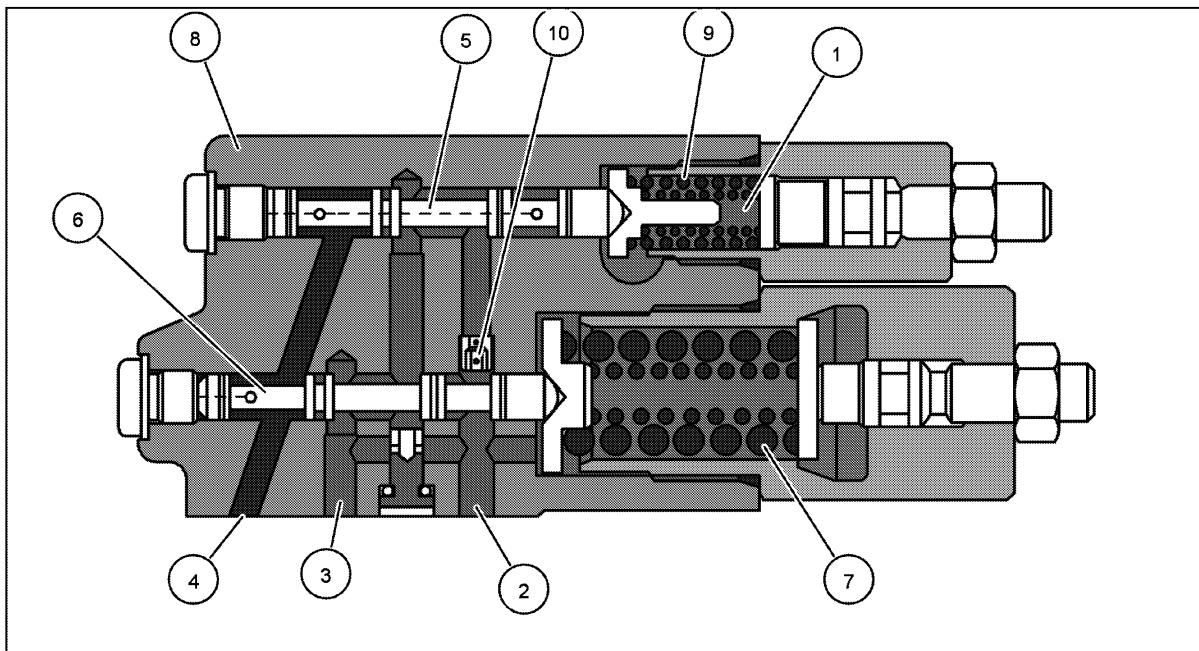

RCPH07CCH037FAE 4

Pressure compensator

1. Signal line pressure	6. High pressure compensator spool
2. Pump case drain	7. High pressure spring
3. Control piston pressure	8. Compensator assembly
4. Piston pump outlet pressure	9. Flow compensator springs
5. Flow compensator spool	10. Orifice plug

Low pressure standby

When there is no demand for flow, there is no pressure signal feedback to the pump, and the pump enters low pressure standby mode. Since there is no place for pump oil to flow, pressure builds at the pump outlet passage. This pressure is directed, through internal passages in the pump back plate, to the end of the compensator spool opposite the spring.

The spring acting on the flow compensator spool allows the spool to move at a **2500 - 2700 kPa (360 - 390 psi)** differential pressure. At this pressure, the flow compensator spool moves down and allows oil to flow into the passage to the pump control piston.

Pressure on this control piston tilts the pump swash plate against the swash plate control spring to a near neutral position. In this condition, the pump provides just enough flow to make up for internal leakage, thus maintaining a minimum system pressure of **2500 - 2700 kPa (360 - 390 psi)**.

The pump remains in the low pressure standby position as long as there is no pressure or flow demand from the hydraulic system. In this mode, the pump produces very little heat and absorbs very little horsepower from the engine.

Engine start up

Before the engine is started, the pump swash plate angle is at its maximum angle. As soon as the engine is cranked by the starter motor, the pressure and flow compensating (PFC) pump produces flow and pressure builds in the pump delivery passage. When this pressure reaches **2500 - 2700 kPa (360 - 390 psi)** the pump enters its low pressure standby mode. This occurs almost instantly and makes engine starting easier.

Pressure/flow delivery and compensation

When oil is required in the system, flow is controlled by the difference in pressure at opposite ends of the compensator spool.

When a control valve is operated, pressure at the outlet of the piston pump drops slightly. Spring and signal line pressure shift the flow compensator spool away from the spring end, allowing oil from the control piston to drain past the spool and to tank.

As the oil drains out of the control piston, the swash plate angle increases and pump flow rises until the flow demand has been met. The flow from the pump is determined by the size of the orifice in the control valve which is being operated. This orifice is created by limiting the main valve spool travel within the control valve.

When a control valve is operated, oil pressure in the circuit being supplied increases to its operating pressure. This pressure is transmitted through the sensing line to the spring end of the compensator spool.

Increased flow demand

When an additional control valve is operated, pressure drops slightly at the pump pressure passage. The compensator spool moved up and allows the oil behind the control piston to drain to tank. The swash plate moves and pump flow increases until the extra demand for flow has been met.

Pressure at the pump outlet increases until it is **2500 - 2700 kPa (360 - 390 psi)** above the signal line pressure. This pressure increase moves the pump compensator spool against the spring, allowing sufficient flow past the spool to the control piston. This action on the piston moves the swash plate to a position where increased flow is maintained and the pressure stabilized.

Decreased flow demand

When flow demand is reduced, pump pressure increases until the pump outlet pressure exceeds the signal line pressure by more than **2500 - 2700 kPa (360 - 390 psi)**. The flow compensator spool moves down to allow some oil to flow into the pump control piston. This action on the piston destrokes the pump against the spring and reduces pump flow.

When pump flow falls to match the reduced demand, the difference in pressure sensed on the opposite sides of the compensator spool returns to **2500 - 2700 kPa (360 - 390 psi)**. The compensator spool moves and blocks off the passage to the control piston, which locks the swash plate at that pumping angle.

High pressure standby

The hydraulic system high pressure standby is set for **20500 - 21500 kPa (2975 - 3120 psi)** through the high pressure compensator pressure setting. Additional protection is provided by maximum system relief valve set at **24500 kPa (3550 psi)**

When system pressure reaches the setting of the high pressure compensator spool, the pump high pressure compensator spool shifts against its spring, allowing the full pump pressure to be applied to the pump control piston. This destrokes the pump very rapidly from full stroke to almost zero (within 8 to 10 milliseconds). The swash plate stabilizes to provide just sufficient flow to make up for internal leakage.

The pump remains in the high pressure standby mode until the valve in operation returns to neutral. When this occurs, signal line feed from the valve is cut off. Signal pressure drops because the drain orifice plug passage is open to the pump case drain. When there is no signal line pressure, the pump immediately returns to a low pressure standby condition.

PRIMARY HYDRAULIC POWER SYSTEM - Static description

Magnum 225 [Z9RH06000 -] CVT Transmission, Magnum 180 [Z9RH06000 -] CVT Transmission, Magnum 190 [Z9RH06000 -] CVT Transmission, Magnum 210 [Z9RH06000 -] CVT Transmission

The hydraulic systems can be separated into the following circuits:

Pressure and flow compensated (PFC) piston pump circuit

- Rear hitch system
- Remote hydraulic system
- Steering system
- Autoguidance system (if equipped)
- Mid mount remote valves (if equipped)
- Trailer brake (if equipped)
- Suspended front axle (if equipped)

Vane pump (regulated circuit)

- Mechanical front wheel drive (MFD)
- PTO and PTO brakes
- Differential lock
- Transmission control valve
- Service brakes and brake booster accumulator
- Remote valve pilot supply
- Mid mount valve pilot supply (if equipped)
- CVT hydro pilot supply

Charge pump

- Charged supply to PFC inlet
- Brake lube
- Transmission lube
- Front drop box lube

PRIMARY HYDRAULIC POWER SYSTEM - Component identification

Magnum 225 [Z9RH06000 -] CVT Transmission, Magnum 180 CVT Transmission, Magnum 190 CVT Transmission, Magnum 210 CVT Transmission

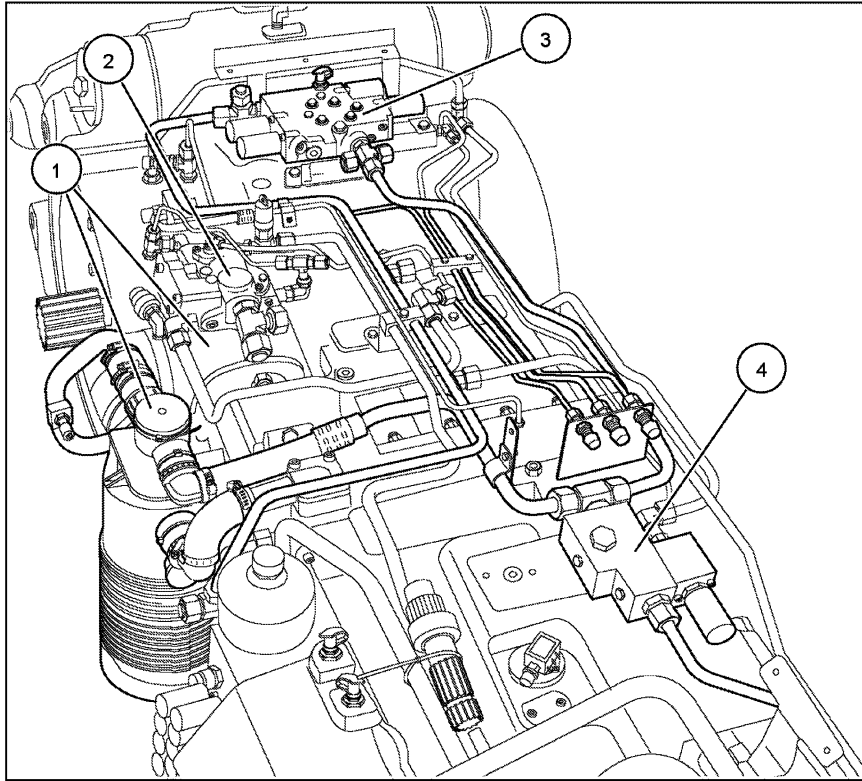

RCPH09CCH037FAE 1

1. Hydraulic pump and filter assembly	3.PTO/Diff lock/MFD control valve
2. Priority valve manifold	4.Brake lubrication manifold

DISTRIBUTION SYSTEMS - PRIMARY HYDRAULIC POWER SYSTEM

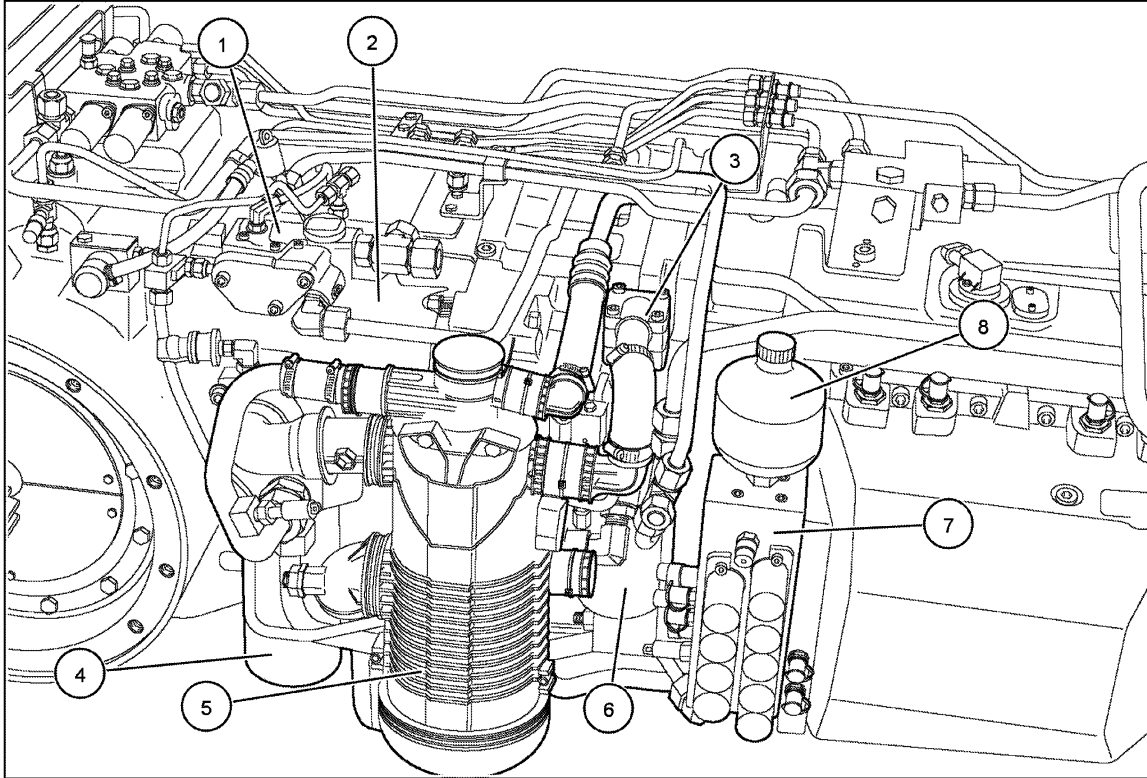

RCPH09CCH026FAE 2

1. Priority valve	5. Main filter housing
2. PFC pump	6. Vane pump filter
3. Vane pump	7. Transmission control valve
4. Charge filter	8. Transmission control valve accumulator

DISTRIBUTION SYSTEMS - PRIMARY HYDRAULIC POWER SYSTEM

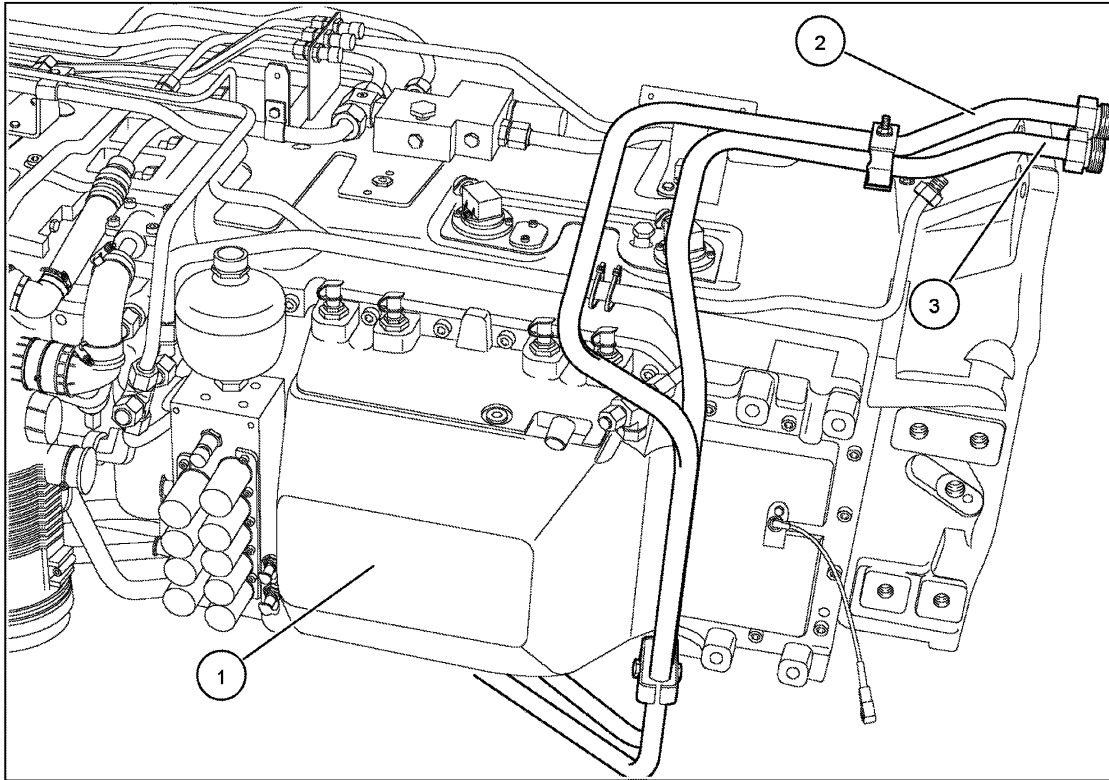

RCPH09CCH029FAE 3

1. Transmission hydrostatic cover assembly	3. Charge flow to cooler
2. Return flow from cooler	

NOTE: The transmission hydrostatic assembly is internal .



Suggest:

If the above button click is invalid.

Please download this document

first, and then click the above link

to download the complete manual.

Thank you so much for reading

DISTRIBUTION SYSTEMS - PRIMARY HYDRAULIC POWER SYSTEM

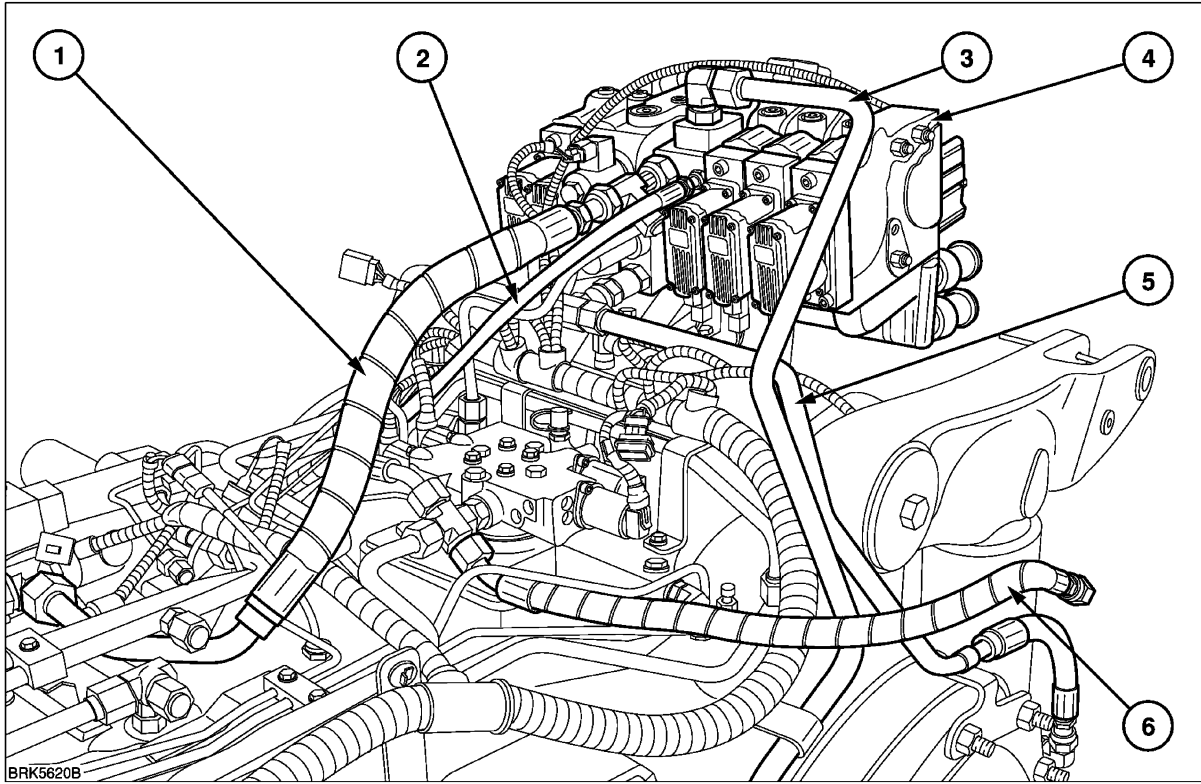

BAIL08CVT005FSA 4

1. Supply to remote/hitch valve assembly	4. Remote valve assembly
2. Load sense line	5. Supply to hitch lift cylinders
3. Return to tank	6. Return flow from hitch cylinder

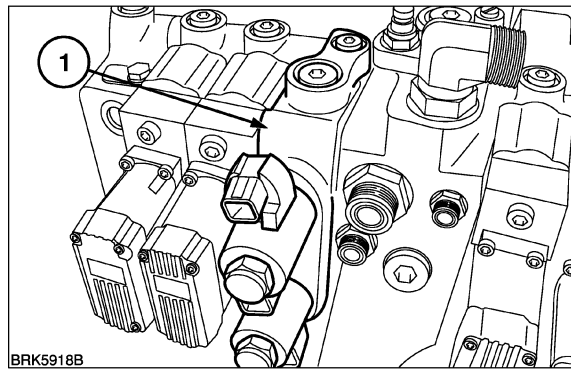

BAIL08CVT084ASA 5

1. Electronic draft control valve (Hitch valve)

<https://www.ebooklibonline.com>

Hello dear friend!

Thank you very much for reading.

Enter the link into your browser.

The full manual is available for immediate download.

<https://www.ebooklibonline.com>