JXU SERIES REPAIR MANUAL

COMPLETE CONTENTS

SECTION 00 - GENERAL INFORMATION	2
SECTION 10 - ENGINE	2
SECTION 18 - CLUTCH	3
SECTION 21 - FRONT TRANSMISSION	4
SECTION 23 - 4WD TRANSFER BOX	6
SECTION 25 - MFD AXLE	7
SECTION 27 - REAR TRANSMISSION	7
SECTION 31 - POWER TAKE-OFF	8
SECTION 33 - BRAKES	9
SECTION 35 - HYDRAULIC SYSTEMS	10
SECTION 41 - STEERING	13
SECTION 44 - WHEEL AXLES (2WD)	14
SECTION 55 - ELECTRICAL SYSTEMS	14
SECTION 90 - PLATFORM, CAB, BODYWORK AND DECALS	20

The following pages are the collation of the contents pages from each section and chapter of the JXU Series Repair manual. Complete Repair part # 87020289.

The sections used through out all Case IH product Repair manuals may not be used for each product. Each Repair manual will be made up of one or several books. Each book will be labeled as to which sections are in the overall Repair manual and which sections are in each book.

The sections listed above are the sections utilized for the JXU Series Tractors.

GENERAL INSTRUCTIONS**IMPORTANT NOTICE**

All maintenance and repair work described in this manual must be performed exclusively by CASE IH service technicians, in strict accordance with the instructions given and using any specific tools necessary.

Anyone performing the operations described herein without strictly following the instructions is personally responsible for any eventual injury or damage to property.

SHIMMING

For each adjustment operation, select adjusting shims and measure individually using a micrometer, then add up the recorder values. Do not rely on measuring the entire shimming set, which may be incorrect, or the rated value indicated for each on shim.

ROTATING SHAFT SEALS

For correct rotating shaft seal installation, proceed as follows:

- before assembly, allow the seal to soak in the oil it will be sealing for at least thirty minutes;
- thoroughly clean the shaft and check that the working surface on the shaft is not damaged;
- position the sealing lip facing the fluid; with hydrodynamic lips, take into consideration the shaft rotation direction and position the grooves so that they will deviate the fluid towards the inner side of the seal;
- coat the sealing lip with a thin layer of lubricant (use oil rather than grease) and fill the gap between the sealing lip and the dust lip on double lip seals with grease;
- insert the seal in its seat and press down using a flat punch; do not tap the seal with a hammer or mallet;
- whilst inserting the seal, check that the it is perpendicular to the seat; once settled, make sure that it makes contact with the thrust element, if required;
- to prevent damaging the seal lip on the shaft, position a protective guard during installation operations.

O-RING "SEALS"

Lubricate the O-RING seals before inserting them in the seats, this will prevent them from overturning and twisting, which would jeopardise sealing efficiency.

SEALING COMPOUNDS

Apply one of the following sealing compounds on the mating surfaces marked with an X: RTV SILMATE, RHO-DORSIL CAF 1 or LOCTITE PLASTIC GASKET.

Before applying the sealing compound, prepare the surfaces as follows:

- remove any incrustations using a wire brush;
- thoroughly de-grease the surfaces using one of the following cleaning agents: trichlorethylene, petrol or a water and soda solution.

BEARINGS

When installing bearings it is advised to:

- heat the bearings to 176 to 194 °F (80 to 90 °C) before fitting on the shafts;
- allow the bearings to cool before installing them.

SPRING PINS

When fitting split socket elastic pins, ensure that the pin notch is positioned in the direction of the force required to stress the pin.

Spiral spring pins do not require special positioning

SPARE PARTS

Only use original **CASE IH spare parts**, bearing the logo shown below.

Only original spare parts guarantee the same quality, duration and safety as they are the same parts that are assembled during production.

Only original **CASE IH spare parts** can offer this guarantee.

When ordering spare parts, always provide the following information:

- vehicle model (commercial name) and frame number;
- engine type and number;
- part number of the ordered part, which can be found in the "Microfiches" or the "Spare Parts Catalogue", used for order processing.

TOOLS

The tools that CASE IH propose and illustrate in this manual are:

- specifically researched and designed for use with CASE IH vehicles;
- essential for reliable repair operations;
- accurately built and rigorously tested so as to offer efficient and long-lasting operation.

By using these tools, repair personnel will benefit from:

- operating in optimal technical conditions;
- obtaining the best results;
- saving time and effort;
- working in safe conditions.

CAUTION

Wear limit values indicated for certain parts are recommended, but not binding. The terms "front", "rear", "right-hand" and "left-hand" (when referred to different parts) are intended as seen from the driving position with the vehicle in the normal direction of movement.

MOVING THE TRACTOR WITH THE BATTERY REMOVED

External power supply cables should only be connected to the respective positive and negative cable terminals, using efficient clamps that guarantee adequate and secure contact.

Disconnect all services (lights, windshield wipers, etc.) before starting the vehicle.

If the vehicle electrical system requires checking, carry out operations with the power supply connected; Once checking is completed, disconnect all services and switch off the power supply before disconnecting the cables.

<https://www.ebooklibonline.com>

Hello dear friend!

Thank you very much for reading.

Enter the link into your browser.

The full manual is available for immediate download.

<https://www.ebooklibonline.com>

SAFETY REGULATIONS

WARNING AND DANGER SYMBOL



This warning symbol points out important messages concerning your safety.

Carefully read the following safety regulations and observe advised precautions in order to avoid potential hazards and safeguard your health and safety.

In this manual the symbol is accompanied by the following key-words:

WARNING - Warnings concerning unsuitable repair operations that may jeopardise the safety of Service personnel.

DANGER - Specific warnings concerning potential hazards for operator safety or for other persons directly or indirectly involved.



ACCIDENT PREVENTION

Most accidents or injuries that occur in workshops are the result of non-observance of simple and fundamental safety regulations.

For this reason, IN MOST CASES THESE ACCIDENTS CAN BE AVOIDED by foreseeing possible causes and consequently acting with the necessary caution and care.

Accidents may occur with all types of vehicles, regardless of how well it was designed and built.

A careful and judicious service technician is the best guarantee against accidents.

Precise observance of the most basic safety rule is normally sufficient to avoid many serious accidents.

DANGER. Never carry out any cleaning, lubrication or maintenance operations when the engine is running.

SAFETY REGULATIONS

GENERAL

- Carefully follow specified repair and maintenance procedures.
- Do not wear rings, wristwatches, jewellery, unbuttoned or loose articles of clothing such as: ties, torn clothing, scarves, open jackets or shirts with open zips that may remain entangled in moving parts.
It is advised to wear approved safety clothing, e.g.: non-slip footwear, gloves, safety goggles, helmets, etc.
- Do not carry out repair operations with someone sitting in the driver's seat, unless the person is a trained technician who is assisting with the operation in question.

- Operate the vehicle and use the implements exclusively from the driver's seat.
- Do not carry out operations on the vehicle with the engine running, unless specifically indicated.
- Stop the engine and check that the hydraulic circuits are pressure-free before removing caps, covers, valves, etc.
- All repair and maintenance operations must be carried out using extreme care and attention.
- Service steps and platforms used in the workshop or elsewhere should be built according to standard accident prevention regulations.
- Disconnect the batteries and label all controls to indicate that the vehicle is being serviced. Any parts that are to be raised must be locked in position.
- Do not check or fill fuel tanks, accumulator batteries, nor use starting liquid when smoking or near naked flames, as these fluids are inflammable.
- Brakes are inoperative if manually released for repair or maintenance purposes.
Use blocks or similar devices to secure the machine in these conditions.
- The fuel nozzle should always be in contact with the filling aperture. Maintain this position until filling operations are completed in order to avoid possible sparks caused by the accumulation of static electricity.

- Only use specified towing points for towing the tractor, connect parts carefully. Make sure that all pins and/or locks are secured in position before applying traction.
Never remain near the towing bars, cables or chains that are operating under load.
- Transport vehicles that cannot be driven using a trailer or a low-loading platform trolley, if available.
- When loading or unloading the vehicle from the trailer (or other means of transport), select a flat area capable of sustaining the trailer or truck wheels, firmly secure the tractor to the truck or trailer and lock the wheels in the position.
- Electric heaters, battery-chargers and similar equipment must only be powered by auxiliary power supplies with efficient ground insulation to avoid electrical shock hazards.
- Always use suitable hoisting or lifting devices when raising or moving heavy parts.
- Take extra care if bystanders are present.
- Never pour gasoline or diesel oil into open, wide or low containers.
- Never use gasoline, diesel oil or other inflammable liquids as cleaning agents. Use non-inflammable, non toxic commercially available solvents.
- Wear safety goggles with side guards when cleaning parts with compressed air.
- Limit the air pressure to a maximum of 2.1 bar, according to local regulations.
- Do not run the engine in confined spaces without suitable ventilation.
- Do not smoke, use naked flames, or cause sparks in the area when fuel filling or handling highly inflammable liquids.
- Never use naked flames for lighting when working on the machine or checking for "leaks".
- All movements must be carried out carefully when working under, on or near the vehicle and wear protective equipment: helmets, goggles and special footwear.
- When carrying out checks with the engine running, request the assistance of an operator in the driver's seat. The operator must maintain visual contact with the service technician at all times.
- If operating outside the workshop, position the vehicle on a flat surface and lock in position. If working on a slope, lock the vehicle in position and move to a flat area as soon as is safely possible.
- Damaged or bent chains or cables are unreliable. Do not use them for lifting or towing. Always use suitable protective gloves when handling chains or cables.
- Chains should always be safely secured. Make sure that the hitch-up point is capable of sustaining the load in question. Keep the area near the hitch-up point, chains or cables free of all bystanders.
- Maintenance and repair operations must be carried out in a CLEAN and DRY area, eliminate any water or oil spillage immediately.
- Do not create piles of oil or grease-soaked rags as they represent a serious fire hazard; store them in a closed metal container.

Before starting the vehicle or implements, make sure that the driver's seat is locked in position and always check that the area is free of persons or obstacles.
- Empty pockets of all objects that may fall unobserved into the vehicle parts when disassembled.
- In the presence of protruding metal parts, use protective goggles or goggles with side guards, helmets, special footwear and gloves.
- When welding, use protective safety devices: tinted safety goggles, helmets, special overalls, gloves and footwear. All persons present in the area where welding is taking place must wear tinted goggles.
NEVER LOOK DIRECTLY AT THE WELDING ARC WITHOUT SUITABLE EYE PROTECTION.
- Metal cables tend to fray with repeated use. Always use suitable protective devices (gloves, goggles, etc.) when handling cables.
- Handle all parts carefully, do not put your hands or fingers between moving parts, wear suitable safety clothing - safety goggles, gloves and shoes.

START UP

- Never start the engine in confined spaces that are not equipped with adequate ventilation for exhaust gas extraction.
- Never place the head, body, limbs, feet, hands or fingers near fans or rotating belts.

ENGINE

- Always loosen the radiator cap slowly before removing it to allow any remaining pressure in the system to be discharged. Coolant should only be added when the engine is stopped or idling, if hot.
- Never fill up with fuel when the engine is running, especially if hot, in order to prevent the outbreak of fire as a result of fuel spillage.
- Never check or adjust fan belt tension when the engine is running.

Never adjust the fuel injection pump when the vehicle is moving.
- Never lubricate the vehicle when the engine is running.

ELECTRICAL SYSTEMS

- If it is necessary to use auxiliary batteries, remember that both ends of the cables must be connected as follows: (+) with (+) and (-) with (-).
- Avoid short-circuiting the terminals. **GAS RELEASED FROM BATTERIES IS HIGHLY INFLAMMABLE.**
- During charging, leave the battery compartment uncovered to improve ventilation.
- Never check the battery charge using "jumpers" (metal objects placed on the terminals).
- Avoid sparks or flames near the battery zone to prevent explosion hazards.
- Before servicing operations, check for fuel or current leaks. Eliminate any eventual leaks before starting work.
- Never charge batteries in confined spaces. Make sure that there is adequate ventilation in order to prevent accidental explosion hazards as a result of the accumulation of gases released during charging operations.
- Always disconnect the battery before performing any kind of servicing on the electrical system.

HYDRAULIC SYSTEMS

- A liquid leaking from a tiny hole may be almost invisible but, at the same time, be powerful enough to penetrate the skin. Check for leaks

using a piece of cardboard, **NEVER USE HANDS.**

- If any liquid penetrates skin tissue, call for medical aid immediately
- Serious skin infections may result if medical attention is not given.
- Use the specific tools when checking pressure values on the hydraulic system.

WHEELS AND TYRES

- Make sure that the tyres are correctly inflated at the pressure specified by the manufacturer.

Periodically check the rims and tyres for damage.
- Stand away from (at the side of) the tyre when checking inflation pressure.
- Only check pressure when the tractor is unloaded and the tyres are cold, to avoid incorrect readings as a result of over-pressure.
- Do not re-use parts of recovered wheels as incorrect welding or brazing may heat the material, causing it to weaken and eventually damage or break the wheel.
- Never cut or weld a rim mounted with an inflated tyre.
- When removing the wheels, lock both the front and rear vehicle wheels.
- Always position support stands when raising the vehicle, in order to conform to current safety regulations.
- Deflate the tyre before removing any objects that may be jammed in the tyre tread.
- Never inflate tyres using inflammable gases; this could cause an explosion and put operator safety at risk.

REMOVAL AND RE-FITTING

- Lift and handle all heavy parts using suitable lifting equipment and make sure that all slings and hooks are correctly secured.
- Handle all parts carefully during lifting operations, keep an eye on the personnel working near the load to be lifted. Never insert hands or fingers between parts, always wear approved accident prevention clothing (goggles, gloves and work boots).
- Avoid twisting chains or metal cables and always wear safety gloves when handling cables or chains.

CONSUMABLES

COMPONENT TO BE FILLED OR TOPPED UP	QUANTITY litres (dm ³)	RECOMMENDED PRODUCTS	INTERNATIONAL SPECIFICATION
Cooling system: without cab:	14	Water and antifreeze liquid, 50% + 50% PREMIUM ANTIFREEZE MS 1710	-
with cab:	16		
Windscreen washer bottle	2	Water and liquid detergent	-
Fuel tank models JX70U, JX80U	115	Decanted and filtered diesel fuel	-
models JX90U, JX100U	135		
Engine sump: without filter:	8.9	Oil CASE IH No 1 15W40	API CF-4/SG CCMC D4 MIL-L-2104E
with filter:	9.5		
Brake control circuit	0.5	LHM	ISO 7308
Hydrostatic steering circuit	1.5	Oil CASE IH HY - TRAN ULTRA	API GL4 ISO 32/46 SAE 10W-30
Front axle: axle casing: model JX70U	4.5		
models JX80U, JX90U and JX100U	7.5		
final drives (each): model JX70U	0.8		
models JX80U, JX90U and JX100U	1.25		
Rear transmission (bevel drive, final drives and brakes), gearbox, hydraulic lift, PTO and hydraulic steering:	54.5		
Front wheel hubs	-	Grease CASE IH 251H EP	NLGI 2
Grease fittings	-		

CAUTION: In order to correctly fill the oil and water tanks observe the existing level indications (e.g. the level on the oil dipstick). Park the tractor on level ground and, where possible, ensure that all of the hydraulic cylinders are fully extended before checking oil levels.

SECTION 10 - ENGINE**Chapter 1 - Engine****CONTENT**

Description	Page
General specifications	2
Main specifications	5
Torque Values	13
Tools	14
Cross-sectional views	16
Lubrication diagram	18
Cooling system diagram	19
Troubleshooting	20
Engine. Removal-Installation	25
Engine. Compression test	40
Engine. Disassembly-Assembly	41
Coolant pump and generator drive belt. Tension adjustment	65
Engine. Checks, dimensions and repairs	66
Valve guides. Replacement	82
Front engine oil seal. Removal-Installation	86
Valve/rocker arm clearance adjustment	89
Coolant pump. Removal-Installation	92
Coolant pump. Overhaul	95
Thermostat valve. Removal-Installation	96
Radiator. Removal-Installation	100

GENERAL SPECIFICATIONS	4 cylinders
Engine, technical type:	
- model JX70U - type 8045.06R.412/414 (BOSCH pump) .	See data Section 3001
- model JX70U - type 8045.06R.513 (BOSCH pump)	See data Section 3001
- model JX80U - type 8045.05R.412/414 (BOSCH pump) .	See data Section 3001
- model JX80U - type 8045.05R.512/513/518 (BOSCH pump)	See data Section 3001
- model JX90U - type 8045.25.402/404 (BOSCH pump) . . .	See data Section 3001
- model JX90U - type 8045.25.502/503 (BOSCH pump) . . .	See data Section 3001
- model JX100U - type 8045.25K.413 (BOSCH pump)	See data Section 3001
- model JX100U - type 8045.25K.513 (BOSCH pump)	See data Section 3001
Cycle	diesel, 4-stroke
Injection	direct
Number of on-line cylinders	4
Cylinder liners	dry force-fitted in cylinder block
Piston diameter	
- model JX70U	3.94 inch (100 mm)
- model JX80U	4.1 inch (104 mm)
- model JX90U	4.1 inch (104 mm)
- model JX100U	4.1 inch (104 mm)
Piston stroke	4.52 inch (115 mm)
Total displacement:	
- model JX70U	3613 cm ³
- model JX80U	3908 cm ³
- model JX90U	3908 cm ³
- model JX100U	3908 cm ³
Compression ratio for models JX70U and JX80U	17:1 normally aspirated
Compression ratio for models JX90U and JX100U	16.5:1 turbocharged
Maximum power:	
- model JX70U	48 kW (65 Hp)
- model JX80U	56 kW (75 Hp)
- model JX90U	63 kW (85 Hp)
- model JX100U	70 kW (95 Hp)
Maximum power speed	2500 rpm
Maximum torque speed - model JX70U	1400 rpm
Maximum torque speed - model JX80U	1400 rpm
Maximum torque speed - model JX90U	1500 rpm
Maximum torque speed - model JX100U	1500 rpm
Number of main bearings	5
Sump pan	structural, cast iron

(continued)

(continued)

GENERAL SPECIFICATIONS	3 cylinders	4 cylinders
Lubrication Pump drive Engine speed/oil pump speed ratio Oil cleaning Normal oil pressure with motor warmed-up and running at maximum speed: For models JX70U and JX80U For model JX90U (operation start) For model JX100U (operation start) Pressure relief valve Valve initial opening pressure For further lubrication technical data	forced, with gear pump camshaft 2:1 mesh filter on oil intake and filtering cartridge on delivery line 42.1 to 56.6 psi (2.9 to 3.9 bar) ≥ 72.5 psi (≥ 5 bar) ≥ 58 psi (≥ 4 bar) incorporated in oil pump housing 50.7 psi (3.5 bar) See page 12	
Cooling system Radiator on models JX70U and JX80U Radiator on models JX90U and JX100U Fan, attached to coolant pump pulley Coolant pump Engine speed/coolant pump speed ratio Temperature control Coolant thermometer Temperature ranges corresponding to each section: - initial white section - middle green section (normal working conditions) - final red section For further cooling system technical data	coolant circulation 3 lines of vertical pipes with copper fins 4 lines of vertical copper pipes intake, 4-blade in sheet-metal centrifugal vane-type 1:1.403 thermostat coloured scale divided into 3 sections 86° to 149° F (30° to 65° C) 149° to 221° F (65° to 105° C) 221° to 239° F (105° to 115° C) See page 12	
Rev counter/hourmeter Operating system Hour counter calibrated for engine speed of	incorporated in control panel from gear on camshaft 1800 rpm	

(continued)

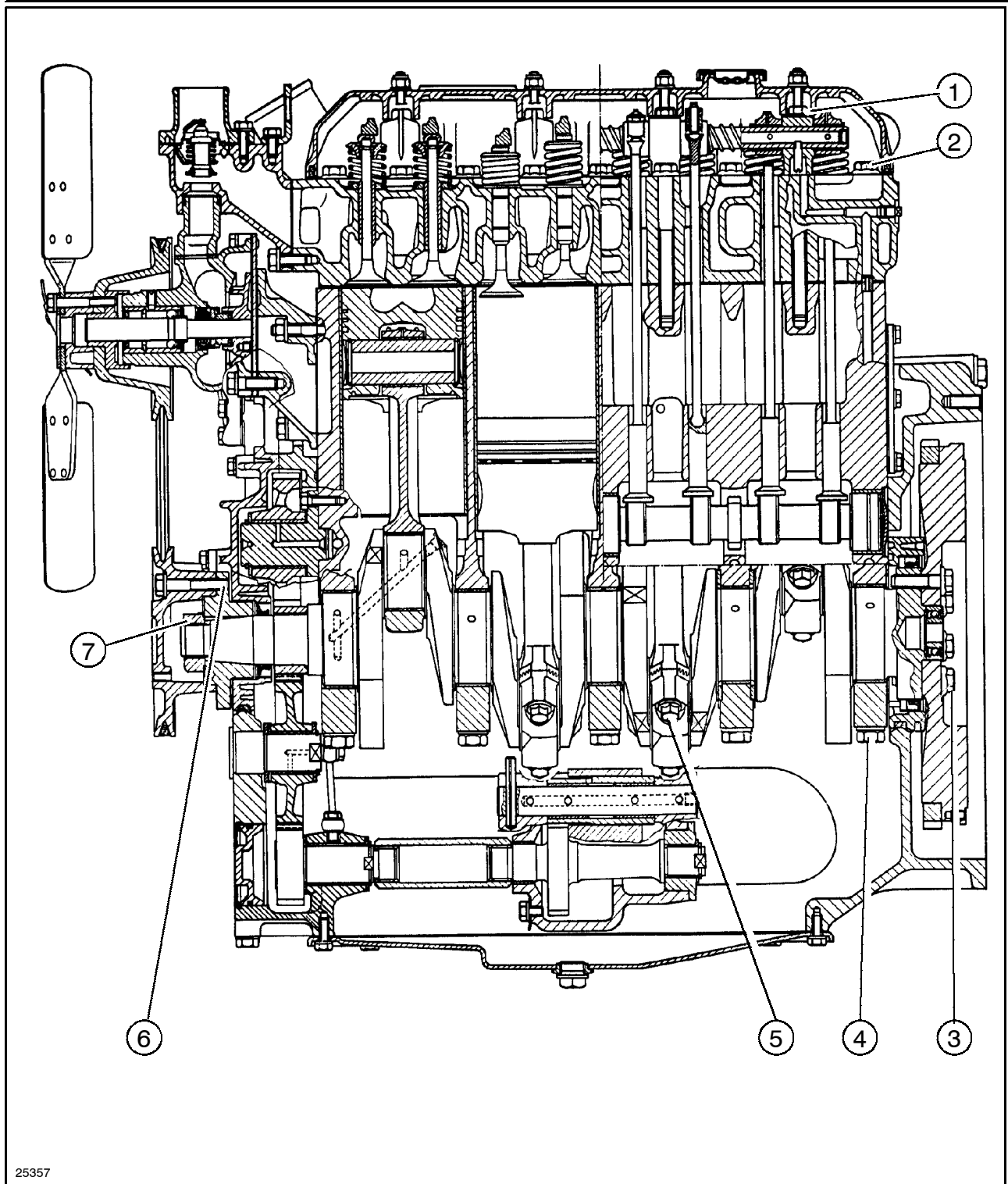

25357

Engine longitudinal cross section - 4-cylinder models JX70U and JX80U

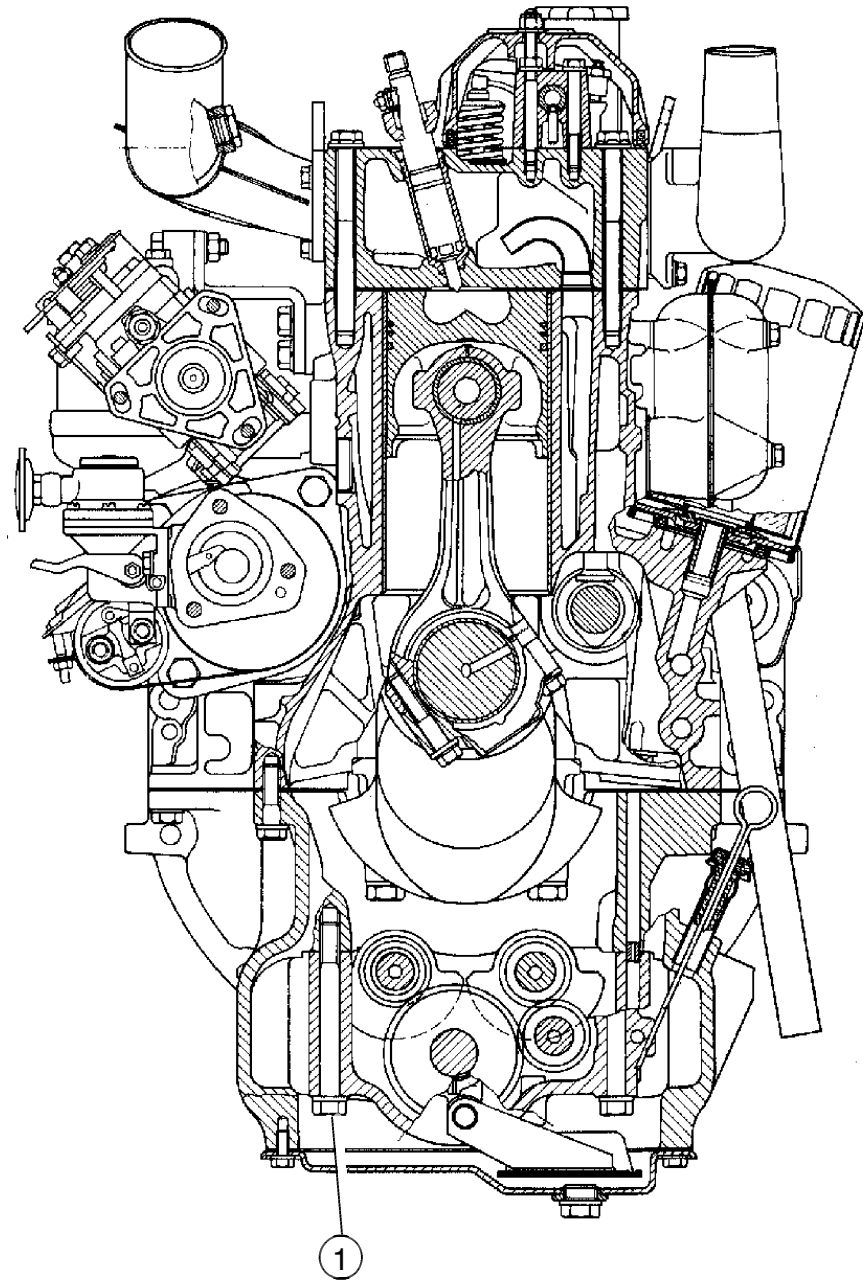

25358

Engine longitudinal cross section - 4-cylinder models JX70U and JX80U

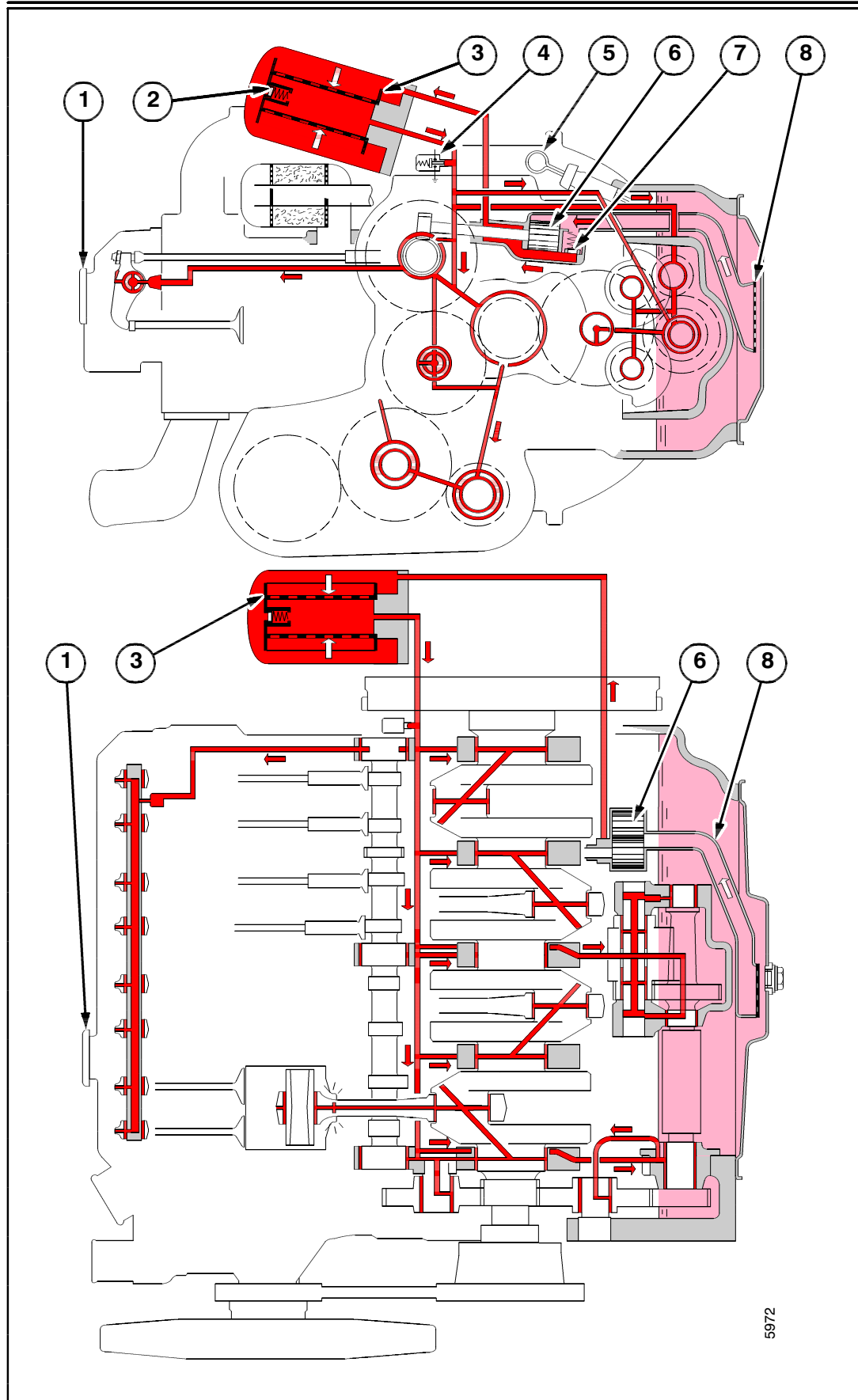

4-cylinder engine lubrication system diagram

1. Oil filler cap - 2. Filter safety valve (intervenes when the oil pressure at the filter infeed exceeds the outfeed pressure by 21.75-24.66 psi (1.5-1.7 bar)
3. Filter - 4. Engine lubrication oil low pressure indicator light switch (on dashboard) - 5. Dipstick - 6. Pump - 7. Oil pressure limiting valve - 8. Mesh filter on intake

5972

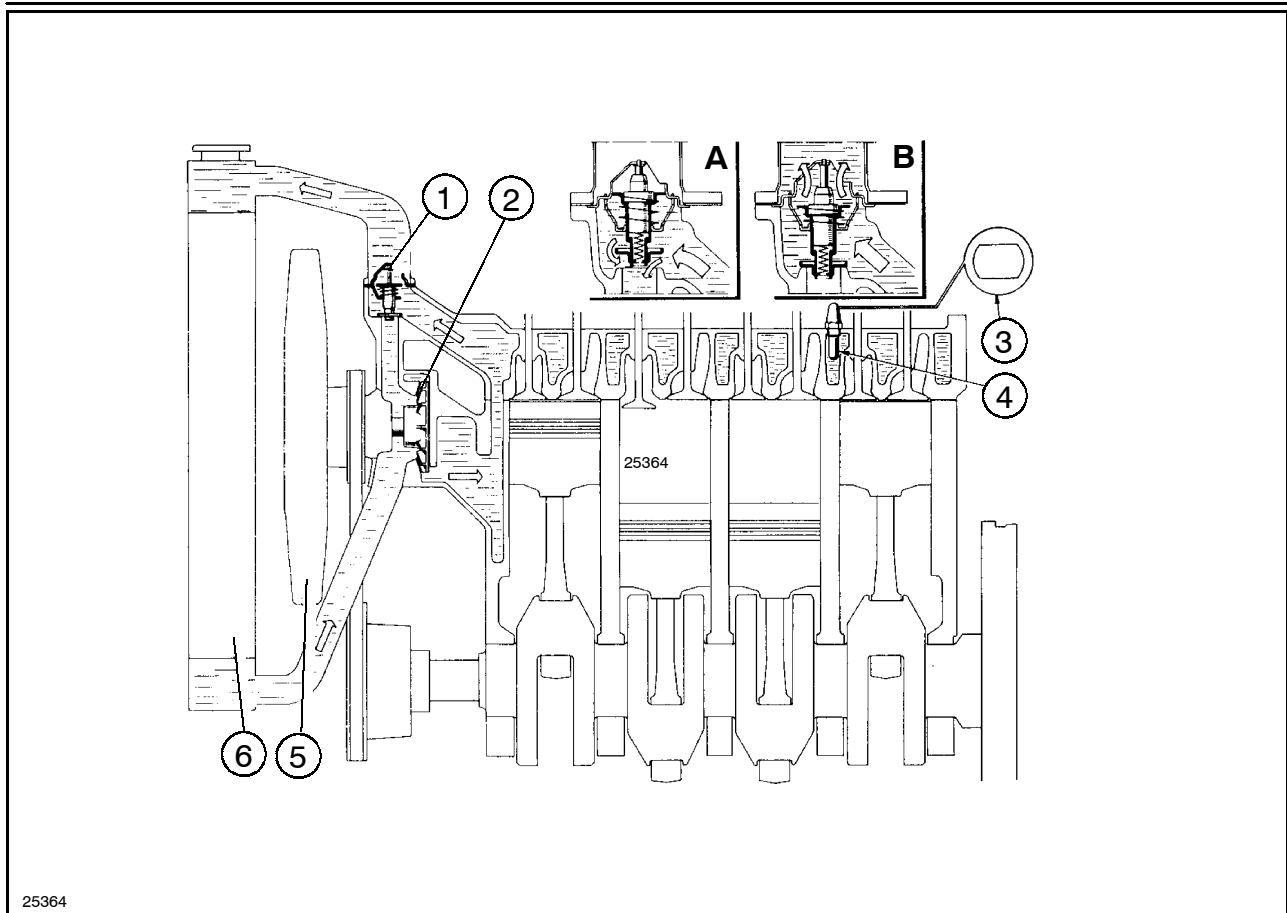

25364

6

Engine cooling system circuit diagram.

- | | |
|---|--|
| A. Coolant circulation with thermostat closed. | 3. Electric thermometer for engine coolant temperature. |
| B. Coolant circulation with thermostat open. | 4. Temperature transmitter. |
| 1. Thermostat. | 5. Fan. |
| 2. Pump. | 6. Radiator. |

ENGINE**Removal-Installation**

⚠ DANGER ⚠

Lift and handle all heavy parts using suitable lifting equipment. Make sure that assemblies or parts are supported by means of suitable slings and hooks. Make sure that no one is standing in the vicinity of the load to be lifted.

⚠ WARNING ⚠

Always use appropriate tools to align fixing holes. NEVER USE YOUR FINGERS OR HANDS.

1. Disconnect the battery negative lead.
2. Drain the oil from the transmission-gearbox housing.
3. Drain off the engine cooling system refrigerant.
4. Remove the tool box and relative support bracket (1).

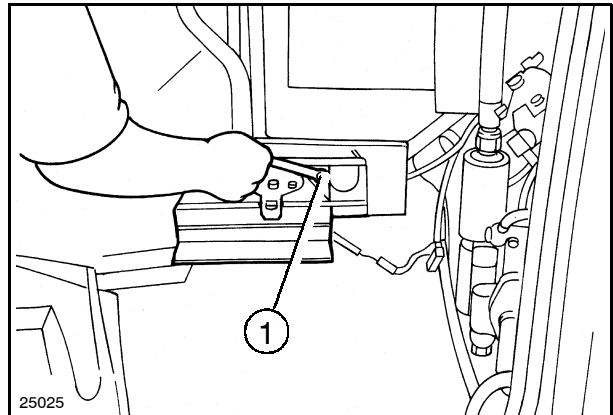

7

5. Remove the split pins, lock pins and front ballast (1).

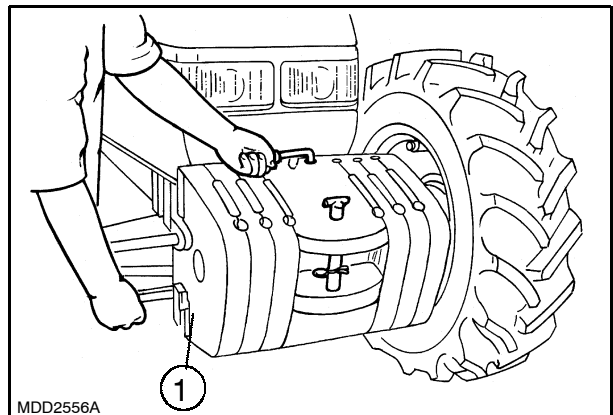

8

6. Remove the exhaust pipe, raise the bonnet and disconnect the front headlights (2) connections (1).

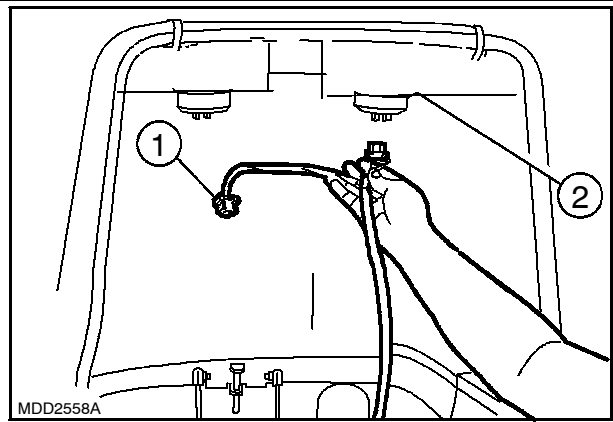

9

7. Remove the gas spring (1) from the bonnet.

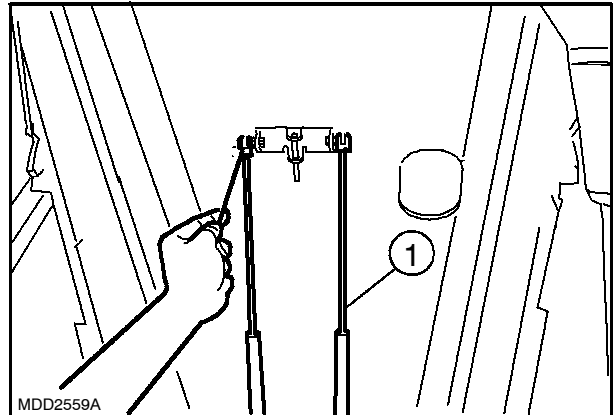

10

8. Unscrew the four bolts (1) retaining the hinge bracket and remove the bonnet.

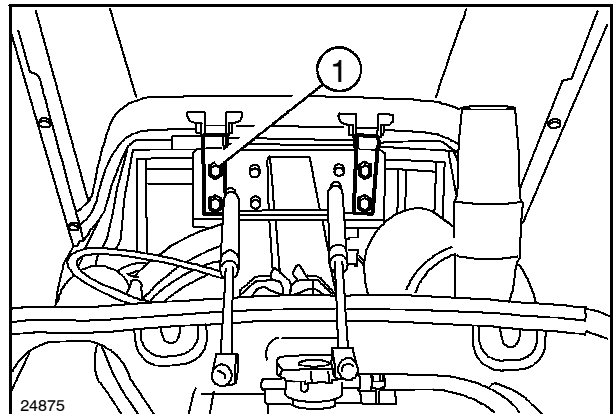

11

9. Remove the fan guard (1) on the right-hand side.

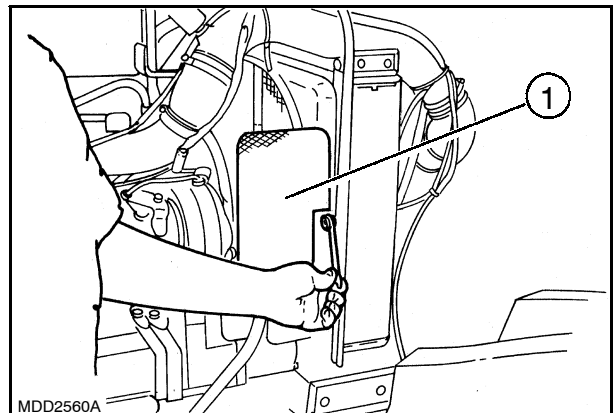

12

10. Remove the metal clamp (1) securing the rigid oil pump and lift oil delivery lines.

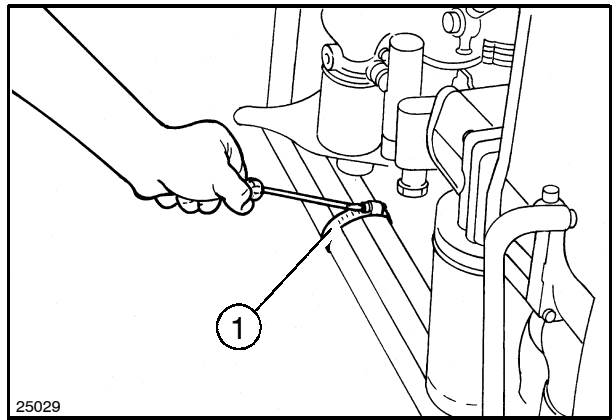

13

11. Extract the sleeve (1) on the services pump priming pipe.

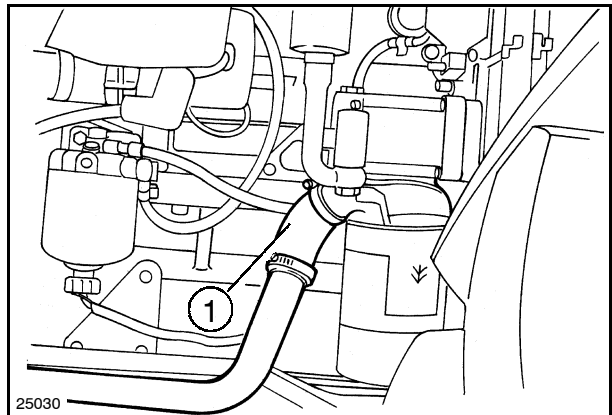

14

12. Extract the sleeve (1) on the lift pump priming pipe.

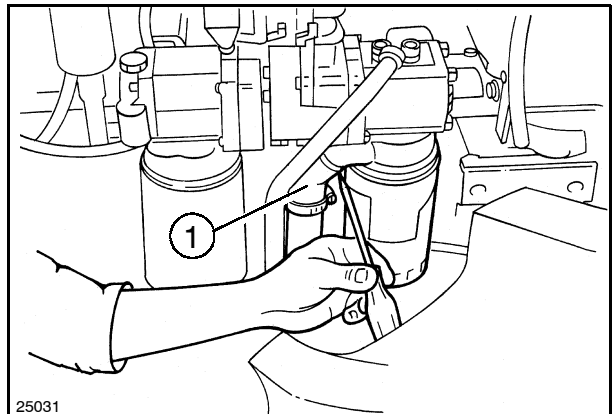

15

13. Detach the lift pump delivery line (1).

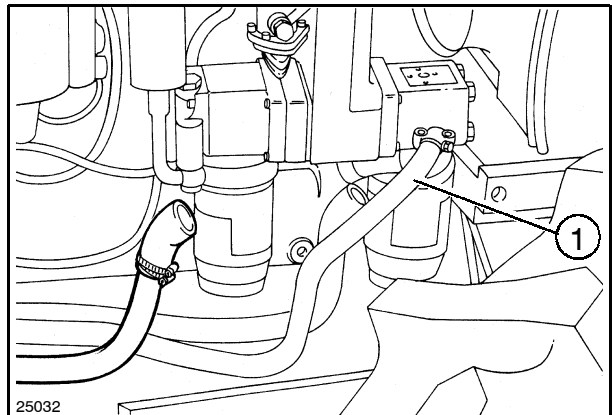

16

14. Detach the fuel line (1) and the glowplug.

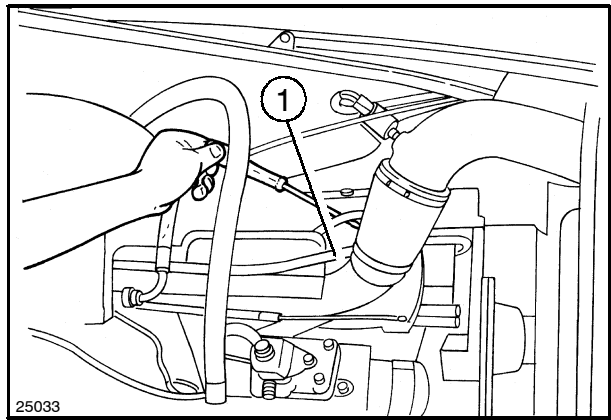

17

15. Detach the injectors fuel recovery line (1) and the tank/decanting filter connecting line.

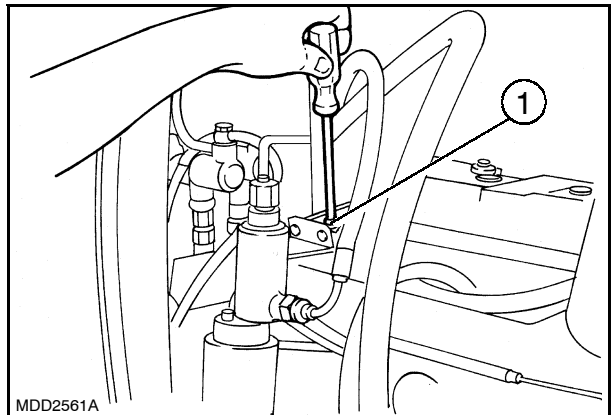

18

16. Detach the support, complete with diesel filter (1).

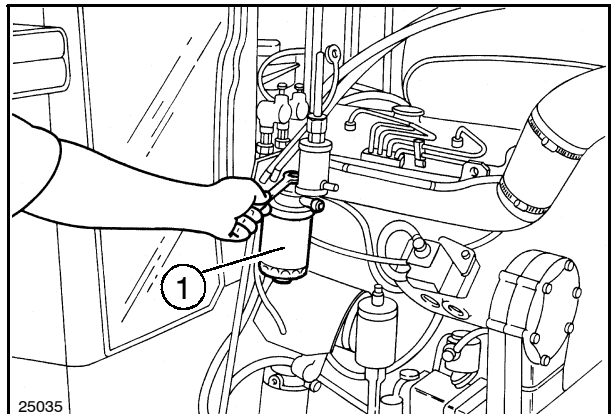

19

17. Remove the brakes flexible piping retaining bracket (1).

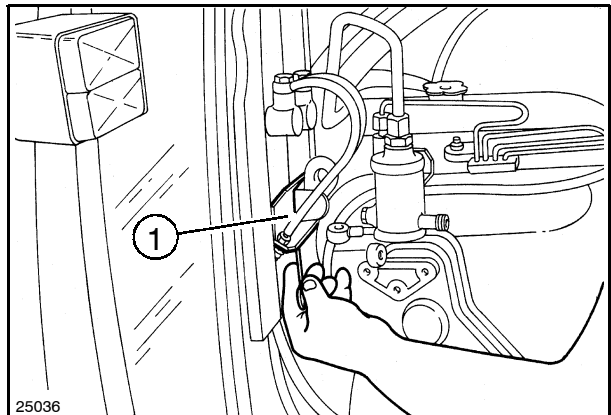

20

18. Disconnect the coolant temperature sensor electrical connection (1).

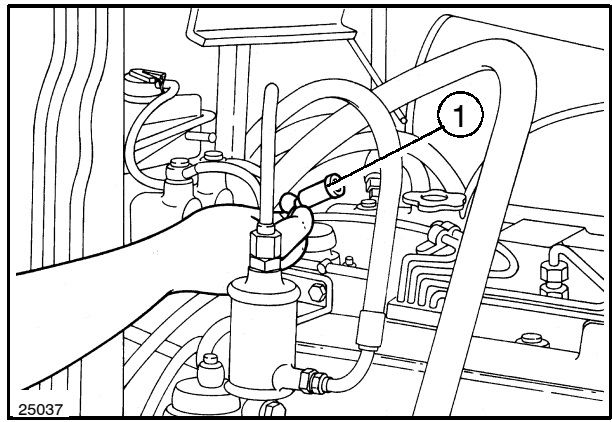

21

19. Disconnect the electrical connections (1) between the cab and the engine.
20. Disconnect the engine oil pressure sensor electrical connection.

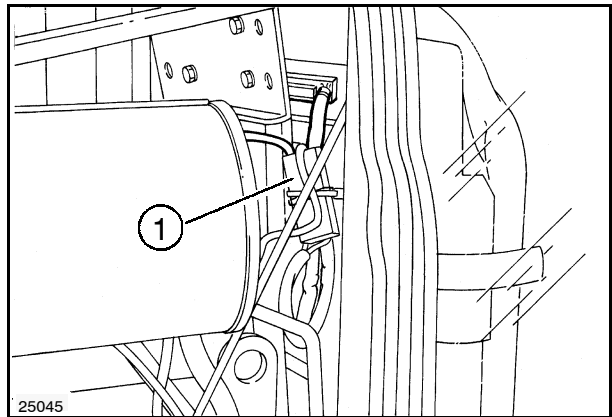

22

21. Detach the rev counter/hourmeter control and remove the clamp from the relative sheath.
22. Disconnect the two power steering oil delivery and return hoses (1).

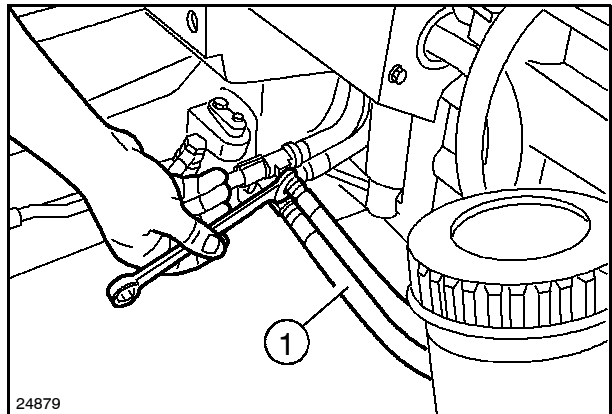

23

23. Disconnect the hose (1) from the anticavitation expansion box (2) located on the power steering unit return line.

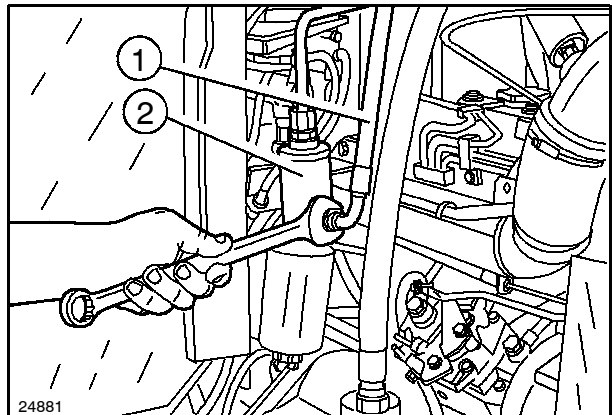

24

24. Unscrew the front central and rear retaining bolts on the front axle shaft guard, then remove the guard (1).

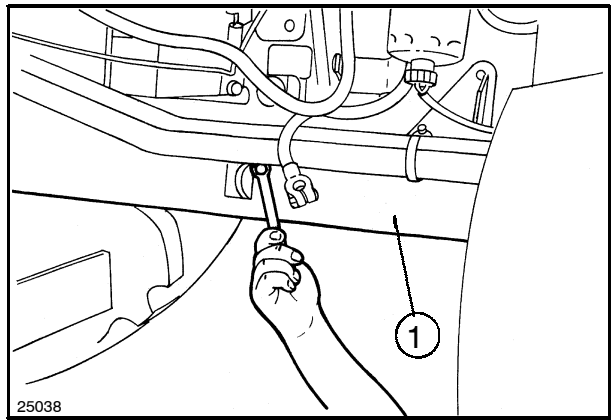

25

25. Remove the circlip (2) and move the sleeve (1) in the direction indicated by the arrow until it is released from the groove on the front axle.

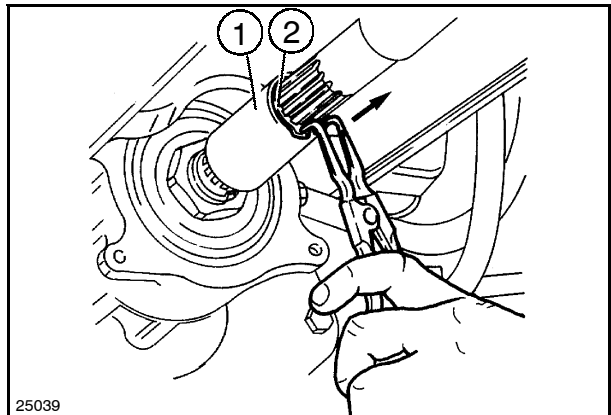

26

26. Remove the circlip (2) and move the sleeve (1) in the direction indicated by the arrow until it is released from the groove on the drive.

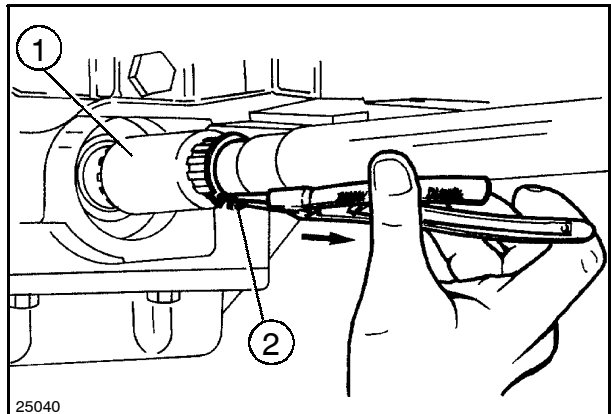

27

27. Remove the drive shaft central support (1) retaining bolts and extract the shaft together with the support.

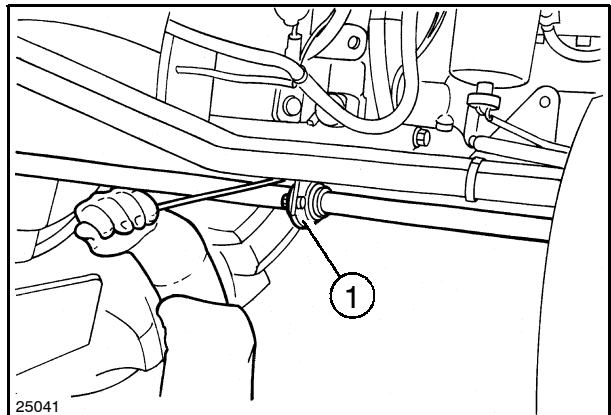

28

28. Detach the 4WD engagement distributor oil delivery line (1).

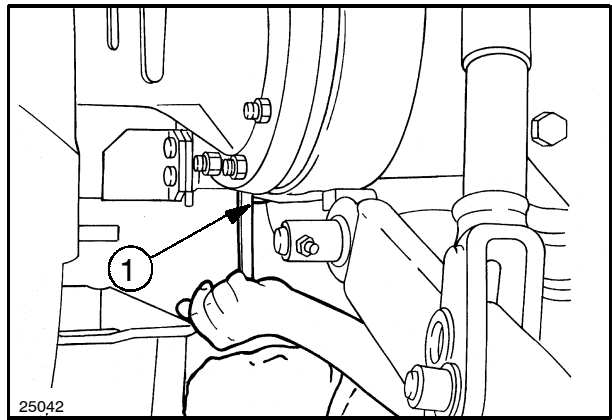

29

29. Remove the four knobs (1) and take off the two dashboard panels (2).

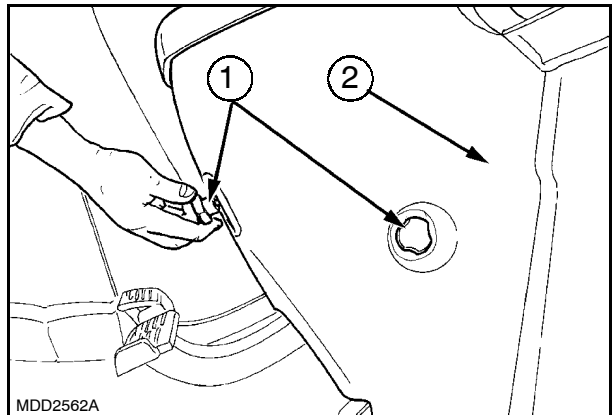

30

30. Extract the differential lock pedal retaining pin from the drive shaft (1), remove the pedal and footboard (2).

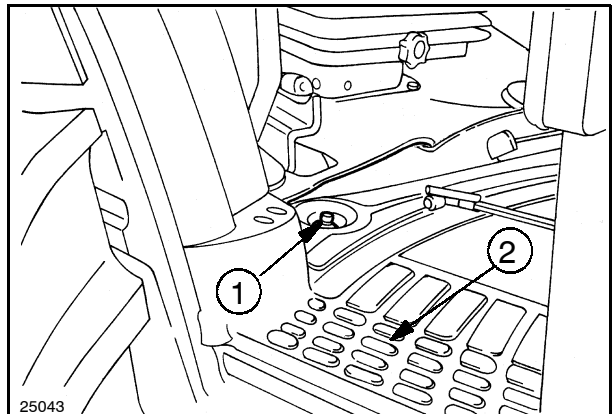

31

31. Remove the footboard and plugs (1) in order to gain access to the engine upper retaining bolts.

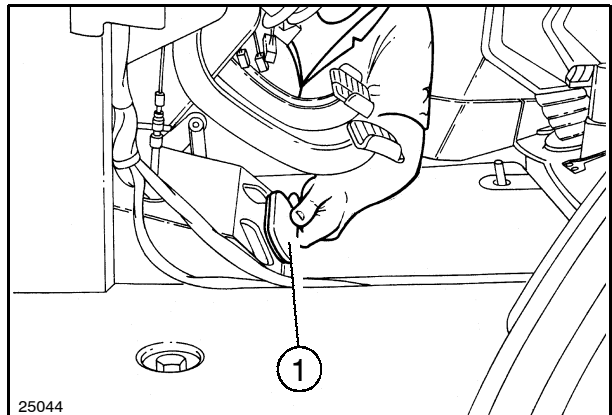

32

32. Remove the accelerator control cable from the pedal (1).

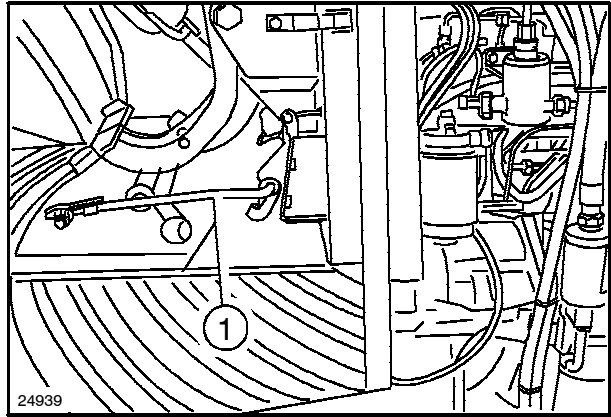

33

33. Remove the two front nuts (2) (one on each side) that secure the cab to the silent-blocks fitted on the supports (1).

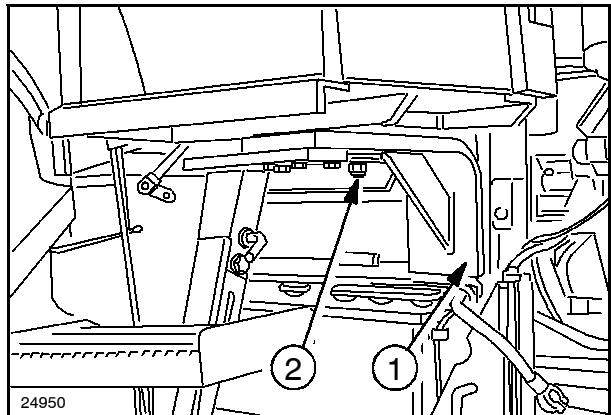

34

34. Raise the cab from the front by approximately 6 cm.

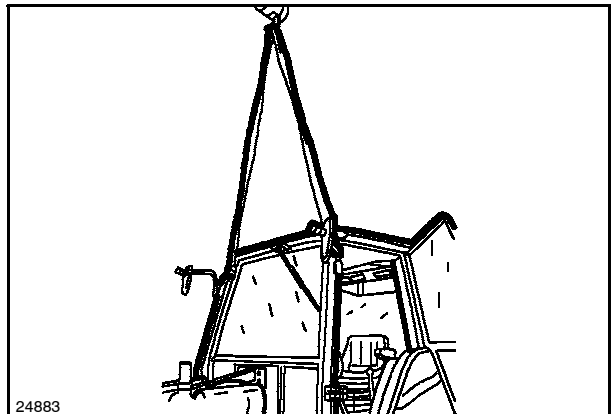

35

35. Unscrew the two nuts and bolts that secure the engine to the transmission, gaining access by means of the two slots (1).

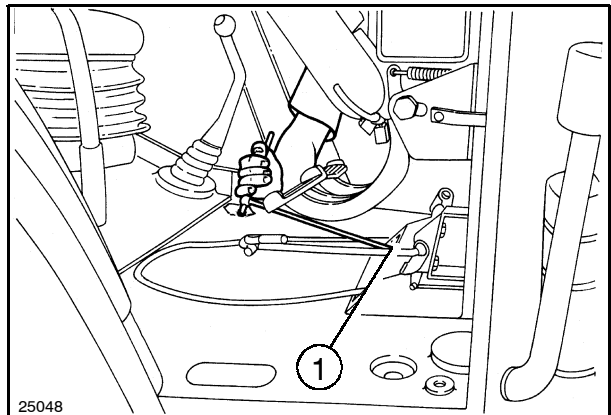

36

36. Unscrew the four lower bolts (1) that secure the engine to the transmission.

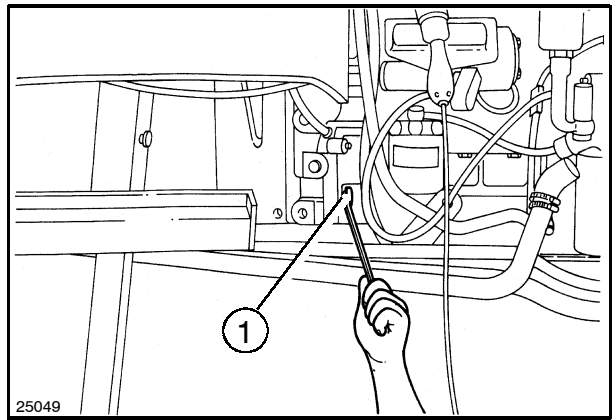

37

37. Position tool **380000236** (2) under the tractor and insert two blocks (1) on the front axle to avoid oscillation.

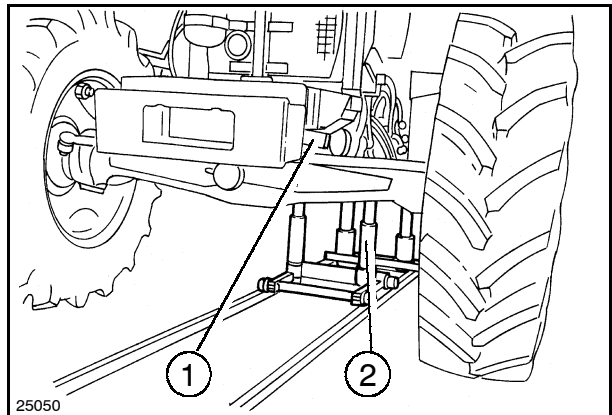

38

38. Position a wooden block (1) at the point where the stand makes contact with the tractor.

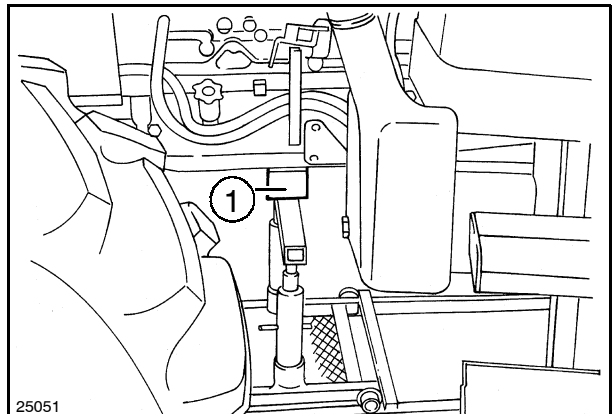

39

39. Position a fixed stand (1) under the towbar and apply the handbrake.

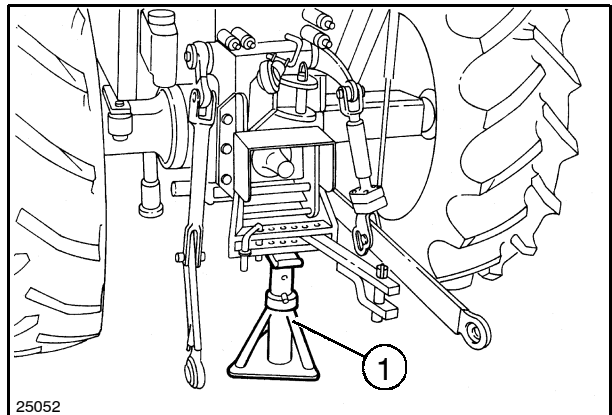

40

40. Detach the cab heating pipes support bracket (1).
41. Unscrew the remaining four engine/transmission retaining bolts.
42. Disconnect the two electrical connectors on the right-hand side of the dashboard.
43. Separate the engine from the transmission.

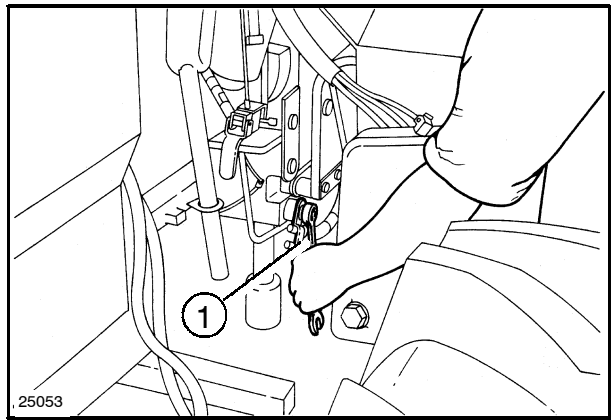

41

44. Remove the spacer (1) located between the engine and the transmission.

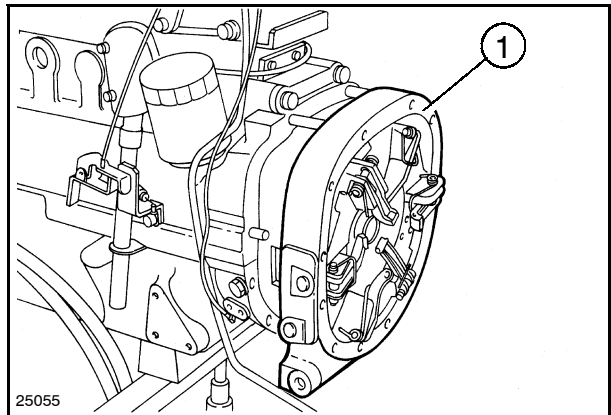

42

45. Position the fixed stand (1) under the ballast support and secure the front wheels with wooden blocks (2).

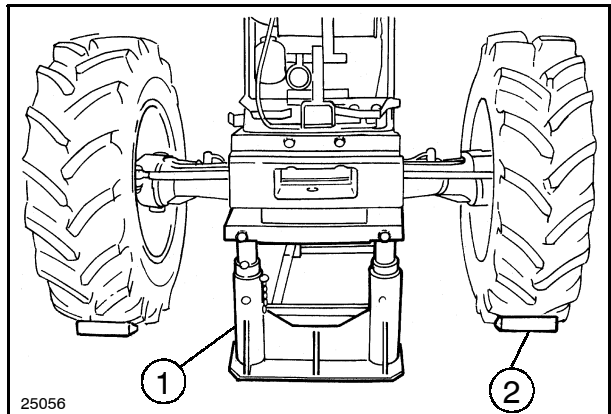

43

46. Insert tool (1) **380000292** in the clutch aperture. Unscrew the six retaining bolts (2) that secure the clutch to the engine flywheel and remove the assembly.

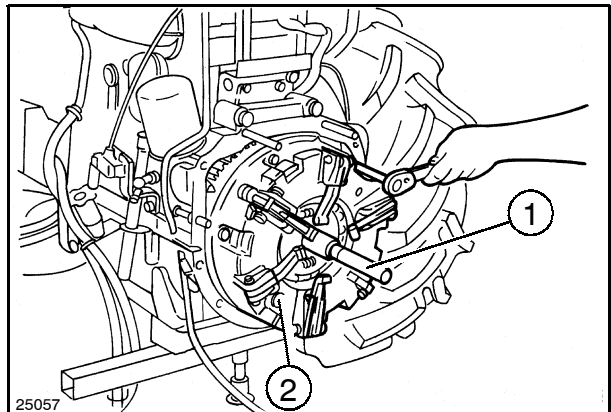

44

47. Remove the radiator bracket retaining screw.
48. Hitch the engine to a hoist using the adjustable chain (1) attached to the engine removal hitch points.

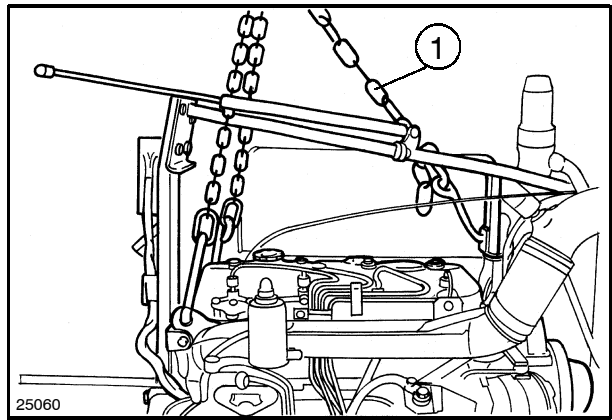

45

49. Remove the lift pump (1) with the relative filter, by unscrewing the four retaining bolts.

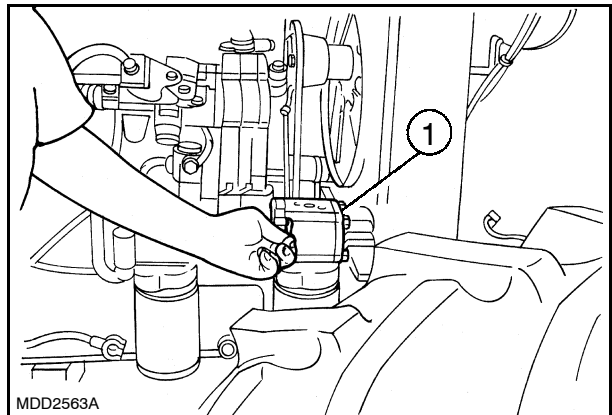

46

50. Disconnect all electrical connections and remove the wiring (1).

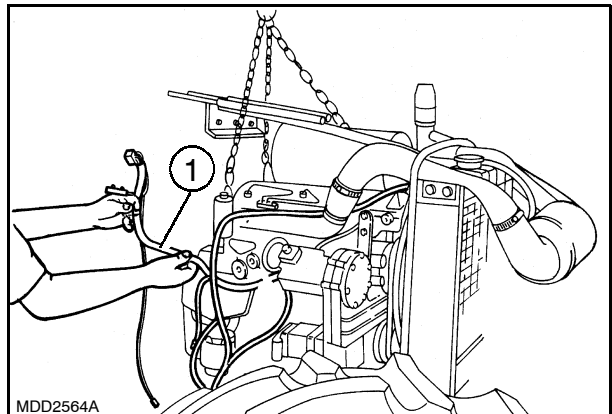

47

51. Loosen the clamp and disconnect the sleeve (1) on the intake manifold.

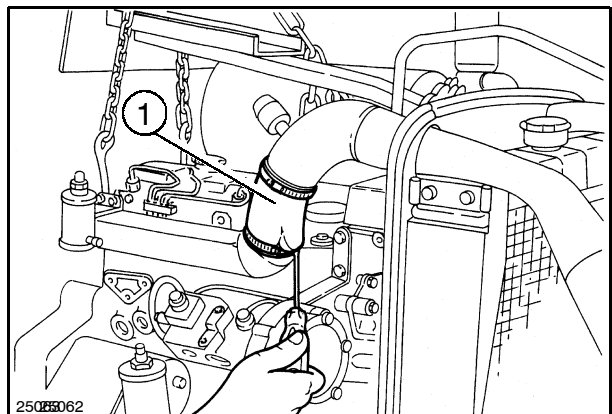

48

52. Remove the fan mesh guard (1) from the left-hand side of the engine.

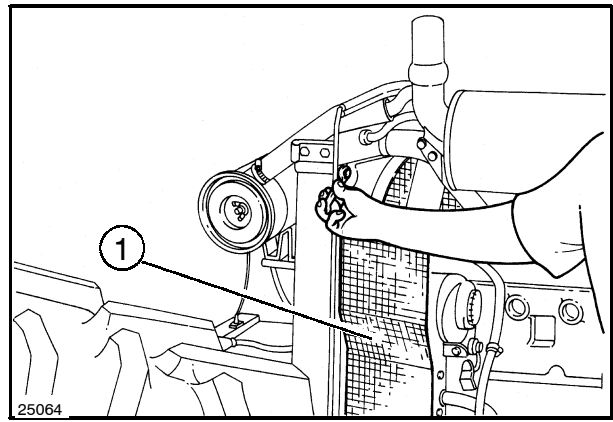

49

53. Remove the clamp and extract the exhaust ejector filter connection (1).

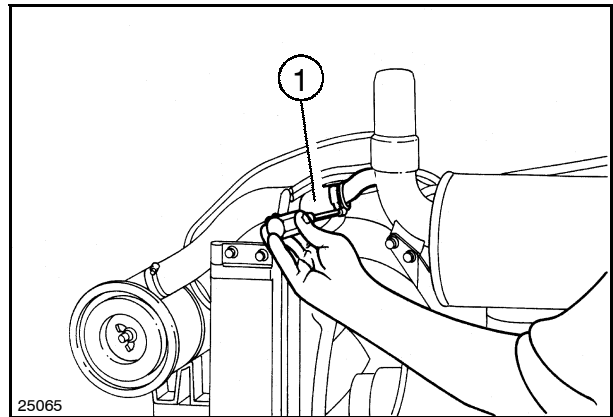

50

54. Remove the exhaust retaining bolts (1) from the support bracket.

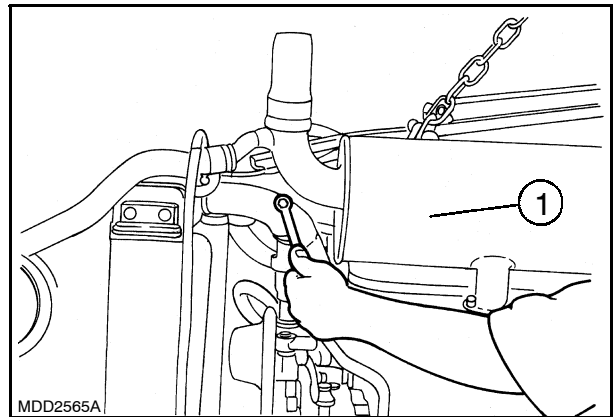

51

55. Remove the clamp and extract the radiator upper sleeve (1).
56. Unscrew the three nuts (2) that secure the silencer to the manifold and remove the unit.

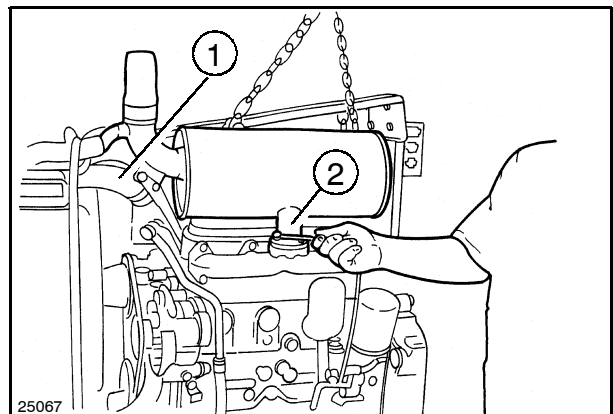

52

57. Slightly raise the engine and position mobile stand (1) under the front axle support.

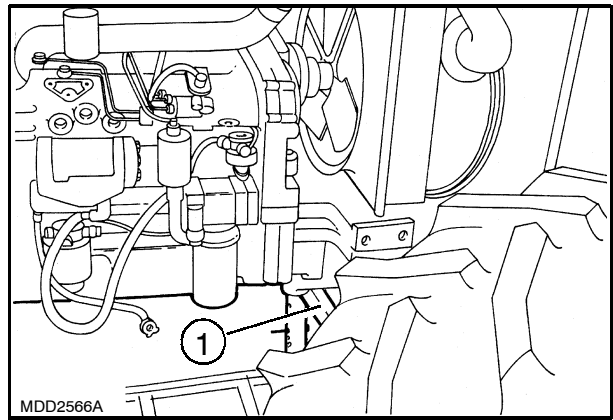

53

58. Remove the clamp and extract the radiator lower sleeve (1).
59. Detach the engine from the axle support, unscrewing the four bolts (2) and position on a wooden platform.

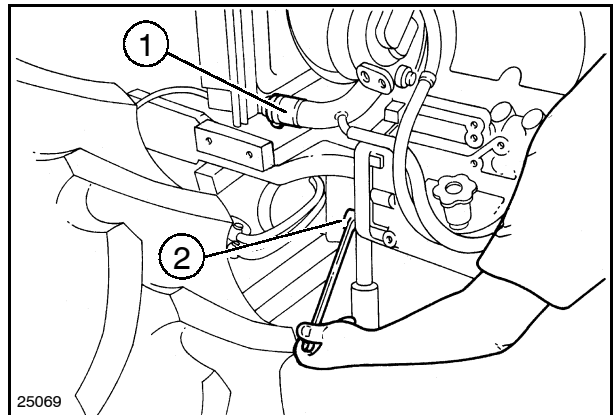

54



Suggest:

If the above button click is invalid.

Please download this document

first, and then click the above link

to download the complete manual.

Thank you so much for reading

60. To refit the engine, proceed as follows:



Always use appropriate tools to align fixing holes.
NEVER USE YOUR FINGERS OR HANDS.

- Apply the torque settings listed on page 13.
- Hitch the engine to an adjustable chain using the three eyebolts. Raise the unit from the wooden platform and position the engine in front of the front axle support. Unite the two units, securing in position with the four retaining bolts.
- Move the mobile stand from the front axle differential casing to the engine oil sump, inserting the previously shaped wooden block.
- Insert the rubber sleeve in the thermostatic valve unit union. Secure the sleeve with an adjustable clamp.
- Also reconnect the lower hose from the radiator with the union on the coolant pump, using a rubber sleeve, then secure all piping with an adjustable metal clamp.
- Refit the lift pump.
- Remove the chain from the engine.
- Insert the air delivery pipe on the intake manifold and secure with the relative clamp.
- Reconnect all electrical connections that were previously disconnected. Thermostart glowplug, coolant temperature sensor, clogged air filter sensor, horn, front axle support weight, engine cut-out wire on injection pump, wires on the alternator and relays, engine oil pressure sensor, starter motor connection, fuel dehydration filter. Secure the wiring with plastic wiring clamps.
- Assemble the clutch using pin **380000292**. Secure the clutch to the engine flywheel using the six bolts.
- Fit the 4WD distributor oil delivery line.
- Clean the spacer and the clutch overdrive contact surfaces, also scrape away the old sealing compound from the engine surface.
- Apply LOCTITE sealing compound on the engine/spacer contact surfaces. Fit the spacer on the stud bolts screwed on the engine.
- Also apply LOCTITE sealing compound on the clutch overdrive casing surfaces.
- Remove the fixed stand from under the ballast support. Remove the blocks from under the front wheels.
- Hitch the engine to an adjustable chain using the three eyebolts.
- Position wooden blocks under the rear wheels, make sure that the handbrake is fully applied and that all fixed and mobile stands are safely positioned.
- The following phase requires the participation of two or three mechanics. Approach the front axle/engine unit to the clutch overdrive casing, pushing the front wheels with the aid of a hoist. Take care not to damage the rigid oil priming lines and the 4WD distributor delivery line. Check that none of the cables or wires remain nipped between parts. Move the crankshaft, by turning the cooling fan, to allow the second shaft to engage. Secure the two units with a few bolts.
- Detach the chain from the engine. Connect the two hooks hitched to the cab handrail to the hook on the hoist. Raise the front part of the cab by 2.36 in. (6 cm).
- Tighten all the engine/clutch overdrive casing retaining bolts.
- Tighten the brake line support bracket on the right-hand side. Lower the hoist, disconnect the chains from the handrail.
- Lower the stands from under the engine oil sump and clutch casing. Remove tool **380000236** and the stand from under the traction bar support.
- Lock the cab in position with the two front bolts.

<https://www.ebooklibonline.com>

Hello dear friend!

Thank you very much for reading.

Enter the link into your browser.

The full manual is available for immediate download.

<https://www.ebooklibonline.com>