JX60, JX70, JX80, JX90, JX95 REPAIR MANUAL COMPLETE CONTENTS

SECTION 00 - GENERAL	2
SECTION 10 - ENGINE	2
SECTION 18 - CLUTCH	7
SECTION 21 - FRONT TRANSMISSION	8
SECTION 23 - MFD TRANSFER BOX	10
SECTION 25 - MFD AXLE	11
SECTION 27 - REAR TRANSMISSION	12
SECTION 31 - POWER TAKE-OFF	13
SECTION 33 - BRAKES	14
SECTION 35 - HYDRAULIC SYSTEMS	15
SECTION 41 - STEERING	18
SECTION 44 - FRONT AXLE AND WHEELS (2WD)	19
SECTION 55 - ELECTRICAL SYSTEM	19
SECTION 90 - PLATFORM, CAB, BODYWORK AND DECALS	25

The following pages are the collation of the contents pages from each section and chapter of the JX Tractor Repair manual. Complete Repair part # 87649366.

The sections used through out all Case IH product Repair manuals may not be used for each product. Each Repair manual will be made up of one or several books. Each book will be labeled as to which sections are in the overall Repair manual and which sections are in each book.

The sections listed above are the sections utilized for the JX Tractors.

SECTION 00 - GENERAL

Chapter 1 - General

CONTENTS

Section	Description	Page
	General Instructions	3
	Health and Safety	5
	Precautionary Statements	15
	Safety	16
	Ecology and the Environment	19
	Minimum Hardware Tightening Torques	20
	Federal Emissions Warranty	22
	California Emission Control Warranty Statement	23
	Consumables	25

⚠ WARNING ⚠

All maintenance and repair work described in this manual must be performed exclusively by CASE IH service technicians in strict accordance with the instructions given and using any specific tools necessary.

⚠ WARNING ⚠

Anyone who performs the operations described herein without strictly following the instructions is personally responsible for resulting injury or damage to property.

⚠ WARNING ⚠

The Manufacturer and all organizations belonging to the Manufacturer's distribution network, including but not restricted to national, regional or local distributors, will accept no responsibility for personal injury or damage to property caused by abnormal function of parts and/or components not approved by the Manufacturer, including those used for maintenance and/or repair of the product manufactured or marketed by the Manufacturer. In any case, the product manufactured or marketed by the Manufacturer is covered by no guarantee of any kind against personal injury or damage to property caused by abnormal function of parts and/or components not approved by the Manufacturer.

<https://www.ebooklibonline.com>

Hello dear friend!

Thank you very much for reading.

Enter the link into your browser.

The full manual is available for immediate download.

<https://www.ebooklibonline.com>

GENERAL INSTRUCTIONS

IMPORTANT NOTICE

All maintenance and repair operations described in this manual should be carried out exclusively by the authorized workshops. All instructions detailed should be carefully observed and special equipment indicated should be used if necessary.

Everyone who carries out service operations described without carefully observing these directives will be directly responsible for resulting consequences.

SHIMMING

At each adjustment, select adjusting shims, measure them individually using a micrometer and then sum up recorded values. Do not rely on measuring the whole shimming set, which may be incorrect, or on the rated value indicated for each shim.

ROTATING SHAFT SEALS

To correctly install rotating shaft seals, observe the following instructions:

- Let the seal soak into the same oil as it will seal for at least half an hour before mounting;
- Thoroughly clean the shaft and ensure that the shaft working surface is not damaged;
- Place the sealing lip towards the fluid. In case of a hydrodynamic lip, consider the shaft rotation direction and orient grooves in order that they deviate the fluid towards the inner side of the seal;
- Coat the sealing lip with a thin layer of lubricant (oil rather than grease) and fill the gap between the sealing lip and the dust lip of double lip seals with grease;
- Insert the seal into its seat and press it down using a flat punch. Do not tap the seal with a hammer or a drift;

- Take care to insert the seal perpendicular to its seat while you are pressing it. Once the seal is settled, ensure that it contacts the thrust element, if required;
- To prevent damaging the sealing lip against the shaft, place a suitable protection during installation.

O RINGS

Lubricate the O rings before inserting them into their seats. This will prevent the O rings from roll over and twisting during mounting, which will jeopardize sealing.

SEALERS

Apply silicone/gasket eliminator over the mating surfaces marked with an X. Before applying the sealer, prepare the surface as follows:

- remove possible scales using a metal brush;
- thoroughly degrease the surfaces using one of the following cleaning agents: trichlorethylene, diesel fuel or a water and soda solution.

BEARINGS

It is advisable to heat the bearings to 80° to 90°C (176° to 194°F) before mounting them on their shafts and cool them down before inserting them into their seats with external tapping.

SPRING PINS

When mounting split socket spring pins, ensure that the pin notch is oriented in the direction of the effort to stress the pin.

Spiral spring pins should not be oriented during installation.

GENERAL INSTRUCTIONS

PRECAUTIONARY NOTICE

Only authorized workshops should carry out maintenance and repair operations on the tractor, or tractor components. Carefully observe all instructions, safety precautions, and the use of equipment such as special tools, as detailed in this manual. Damage to the tractor, or injury to personnel is the direct responsibility of anyone who fails to observe these precautions.

EQUIPMENT NOTICE

The equipment proposed in this manual is:

- Designed and studied expressly for use on Case IH tractors
- Necessary for adequate and reliable repair of the tractor
- Strictly tested for the efficient and long lasting life cycle of the tractor

SPARE PARTS NOTICE

Genuine CASE IH spare parts guarantee the same quality, safety and life cycle as original components. These parts bear the logo.

GENERAL NOTICES

In this manual, the description 'FRONT', 'REAR', 'RIGHT-HAND' and 'LEFT-HAND' refer to the view seen by the operator while in the operator's seat, looking in the direction in which the tractor normally moves.

Wear limits detailed in this manual, although advised, are not binding.

HEALTH AND SAFETY**CONTENTS**

Description	Page
HEALTH AND SAFETY PRECAUTIONS	5
ACIDS AND ALKALIS	6
ADHESIVES AND SEALERS - see Fire	6
ANTIFREEZE - see Fire, Solvents e.g. Isopropanol, Ethylene Glycol, Methanol.	6
ARC WELDING - see Welding.	7
BATTERY ACIDS - see Acids and Alkalis.	7
BRAKE AND CLUTCH FLUIDS (Polyalkylene Glycols) - see Fire.	7
BRAZING - see Welding.	7
CHEMICAL MATERIALS - GENERAL - see Legal Aspects.	7
DO'S	7
DO NOTS	8
CORROSION PROTECTION MATERIALS - see Solvents, Fire.	8
DUSTS	8
ELECTRIC SHOCK	8
EXHAUST FUMES	9
FIBER INSULATION - see Dusts.	9
FIRE - see Welding, Foams, Legal Aspects.	9
FIRST AID	9
FOAMS - Polyurethane - see Fire.	9
FUELS - see Fire, Legal Aspects, Chemicals - General, Solvents.	10
GAS CYLINDERS - see Fire.	10
GENERAL WORKSHOP TOOLS AND EQUIPMENT	11
LEGAL ASPECTS	11
LUBRICANTS AND GREASES	11
PAINTS - see Solvents and Chemical Materials - General.	12
SOLDER - see Welding.	12
SOLVENTS - see Chemical Materials - General Fuels (Kerosene), Fire.	13
SUSPENDED LOADS	13
WELDING - see Fire, Electric Shock, Gas Cylinders.	13

HEALTH AND SAFETY PRECAUTIONS

Many of the procedures associated with vehicle maintenance and repair involve physical hazards or other risks to health. This section lists, alphabetically, some of these hazardous operations and the materials and equipment associated with them. The

precautions necessary to avoid these hazards are identified.

The list is not exhaustive and all operations and procedures and the handling of materials, should be carried out with health and safety in mind.

ACIDS AND ALKALIS - see Battery acids, e.g. caustic soda, sulfuric acid.

Used in batteries and cleaning materials.

Irritant to the skin, eyes, nose and throat. Causes burns.

Avoid splashes to the skin, eyes and clothing. Wear suitable protective gloves and goggles. Can destroy ordinary protective clothing. Do not breathe mists.

Ensure access to water and soap is readily available for splashing accidents.

ADHESIVES AND SEALERS - see Fire

Highly Flammable and combustible.

Generally should be stored in "No Smoking" areas; cleanliness and tidiness in use should be observed, e.g. disposable paper covering benches; should be dispensed from applicators where possible; containers, including secondary containers, should be labelled.

Solvent based Adhesives/Sealers - See Solvents.

Follow manufacturers instructions.

Water based Adhesives/Sealers

Those based on polymer emulsions and rubber lattices may contain small amounts of volatile toxic and harmful chemicals. Skin and eye contact should be avoided and adequate ventilation provided during use.

Follow manufacturers instructions.

Resin based Adhesives/Sealers - e.g. epoxide and formaldehyde resin based.

Mixing should only be carried out in well ventilated areas as harmful or toxic volatile chemicals may be released.

Skin contact with uncured resins and hardeners can result in irritation; dermatitis and absorption of toxic or harmful chemicals through the skin. Splashes can damage the eyes.

Provide adequate ventilation and avoid skin and eye contact. Follow manufacturers instructions.

Anaerobic, Cyanoacrylate and other Acrylic Adhesives

Many are irritant, sensitizing or harmful to the skin. Some are eye irritants.

Skin and eye contact should be avoided and the manufacturers instructions followed.

Cyanoacrylate adhesives (super-glues) must not contact the skin or eyes. If skin or eye tissue is bonded cover with a clean moist pad and get medical attention. do not attempt to pull tissue apart. Use in well ventilated areas as vapors can cause irritation of the nose and eyes.

For two-pack systems see Resin based adhesives/sealers.

Isocyanate (Polyurethane) Adhesives/Sealers - see Resin based Adhesives.

Individuals suffering from asthma or respiratory allergies should not work with or near these materials as sensitivity reactions can occur.

Any spraying should preferably be carried out in exhaust ventilated booths removing vapors and spray droplets from the breathing zone. Individuals working with spray applications should wear supplied air respirators.

ANTIFREEZE - see Fire, Solvents e.g. Isopropanol, Ethylene Glycol, Methanol.

Highly Flammable and Combustible.

Used in vehicle coolant systems, brake air pressure systems, screenwash solutions.

Vapors given off from coolant antifreeze (glycol) arise only when heated.

Antifreeze may be absorbed through the skin in toxic or harmful quantities. Antifreeze if swallowed is fatal and medical attention must be found immediately.

ARC WELDING - see Welding.

BATTERY ACIDS - see Acids and Alkalis.

Gases released during charging are explosive. Never use naked flames or allow sparks near charging or recently charged batteries.

BRAKE AND CLUTCH FLUIDS (Polyalkylene Glycols) - see Fire.

Combustible.

Splashes to the skin and eyes are slightly irritating. Avoid skin and eye contact as far as possible. Inhalation of vapor hazards do not arise at ambient temperatures because of the very low vapor pressure.

BRAZING - see Welding.

CHEMICAL MATERIALS - GENERAL - see Legal Aspects.

Chemical materials such as solvents, sealers, adhesives, paints, resin foams, battery acids, antifreeze, brake fluids, oils and grease should always be used with caution and stored and handled with care. They may be toxic, harmful, corrosive, irritant or highly flammable and give rise to hazardous fumes and dusts.

The effects of excessive exposure to chemicals may be immediate or delayed; briefly experienced or permanent; cumulative; superficial; life threatening; or may reduce life-expectancy.

DO'S

Do remove chemical materials from the skin and clothing as soon as practicable after soiling. Change heavily soiled clothing and have it cleaned.

Do carefully read and observe hazard and precaution warnings given on material containers (labels) and in any accompanying leaflets, poster or other instructions. Material health and safety data sheets can be obtained from Manufacturers.

Do organize work practices and protective clothing to avoid soiling of the skin and eyes; breathing vapors/aerosols/dusts/fumes; inadequate container labelling; fire and explosion hazards.

Do wash before job breaks; before eating, smoking, drinking or using toilet facilities when handling chemical materials.

Do keep work areas clean, uncluttered and free of spills.

Do store according to national and local regulations.

Do keep chemical materials out of reach of children.

SECTION 10 - ENGINE

Chapter 1 - Engine

CONTENTS

Section	Description	Page
	Specifications	2
	Special Tools	10
	Tightening Torques	14
	Angular Torque Data	14
	Sectional Views	15
	Troubleshooting	19
	Overhaul	23
10 001 10	Engine	23
	Removal	23
10 001 54	Installation	34
	Disassembly	36
	Assembly	51
	Rotating Counterweight Dynamic Balancer	51
	Compression Test	61
	Checks, Dimensions, and Repairs	62
	Cylinder Block	62
	Crankshaft, Main Bearings, and Flywheel	64
	Connecting Rods	68
	Pistons	69
	Valves	72
	Tappets	72
	Camshaft	73
	Valve Timing Check	74
	Cylinder Head	75
10 102 70	Rotating Counterweight Dynamic Balancer	76
	Valve Guides	77
	Valve Seats in Cylinder Head	80
	Crankshaft Front Oil Seal	81
	Valve Clearance	87

SPECIFICATIONS

GENERAL SPECIFICATIONS	3-cylinder	4-cylinder
Engine type:		
- JX60 (BOSCH pump; naturally aspirated)	179 cu. in (2.9 L)	-
- JX70 (BOSCH pump; turbocharged)	179 cu. in (2.9 L)	-
- JX80 (BOSCH pump; naturally aspirated)	-	238 cu. in (3.0 L)
- JX90 (BOSCH pump; turbocharged)	-	238 cu. in (3.0 L)
- JX95 (BOSCH pump; turbocharged)	-	238 cu. in (3.0 L)
Cycle	Diesel, 4-stroke	
Fuel injection	Direct	
No. of in-line cylinders	3	4
Cylinder liners	dry force-fitted in cylinder block	
Piston diameter		
- JX60	100 mm (3.937 in.)	-
- JX70	104 mm (4.094 in.)	-
- JX80	-	100 mm (3.937 in.)
- JX90	-	104 mm (4.094 in.)
- JX95	-	104 mm (4.094 in.)
Piston stroke	115 mm	
Total displacement:		
- JX60	2710 cm ³ (165 in ³)	-
- JX70	2931 cm ³ (175 in ³)	-
- JX80	-	3613 cm ³ (220 in ³)
- JX90	-	3908 cm ³ (238 in ³)
- JX95	-	3908 cm ³ (238 in ³)
Compression ratio	17 to 1 naturally aspirated 16.5 to 1 turbocharged	
Maximum power:		
- JX60	40.4 kW (JX60)	-
- JX70	44,1 kW (JX70)	-
- JX80	-	51,5 kW (JX80)
- JX90	-	58,8 kW (JX90)
- JX95	-	70 kW (JX95)
Fast idling speed	2500 rev/min	
Maximum torque (daNm) at 1500 rpm:		
- JX60	20.7 (153 ft-lb)	-
- JX70	25.0 (184 ft-lb)	-
- JX80	-	27.9 (206 ft-lb)
- JX90	-	32.0 (236 ft-lb)
- JX95	-	33.7 (249 ft-lb)
Number of main bearings	4	5
Sump pan	Structural, cast iron	
Rev counter/hourmeter	incorporated in control panel	
Operating system	from gear on camshaft	
Hour counter calibrated for engine speed of	1800 rpm	

Timing System	overhead valves operated camshaft located in engine block through tappets, pushrods and rockers; camshaft is driven by the crankshaft through helical gears
Intake:	
- start: before TDC	12°
- end: after BDC	31°
Exhaust:	
- start: before BDC	50°
- end: after TDC	16°
Valve clearance for timing check	0.45 mm (0.0177 in.)
Valve clearance for normal running (engine cold):	
- intake	0.30 ± 0.05 mm (0.01 ± 0.002 inches)
- exhaust	0.30 ± 0.05 mm (0.01 ± 0.002 inches)

CRANKCASE/CYLINDER BLOCK DATA	mm (in)
Cylinder block	cast-iron monobloc with parent-bore cylinders, incorporating seatings for crankshaft bearings, camshaft and pushrod/tappet assemblies
Internal diameter of cylinders	104.000 to 104.024 (4.094 - 4.095)
Maximum permissible cylinders ovality or taper due to wear ⁽¹⁾ .	0.12 (0.004)
Diameter of main shell bearing seats	84.200 to 84.230 (3.314 - 3.316)
Diameter of camshaft bearing seats:	
- front	54.780 to 54.805 (2.156 - 2.157)
- center	54.280 to 54.305 (2.137 - 2.138)
- rear	53.780 to 53.805 (2.117 - 2.118)
Diameter of standard tappet bores in crankcase	15.000 to 15.018 (0.590 - 0.591)
Tappet oversizes	0.1 - 0.2 - 0.3 (0.004 - 0.007 - 0.011)

⁽¹⁾ Measure in the area swept by piston rings, both parallel and perpendicular to the crankshaft axis.

SECTIONAL VIEWS

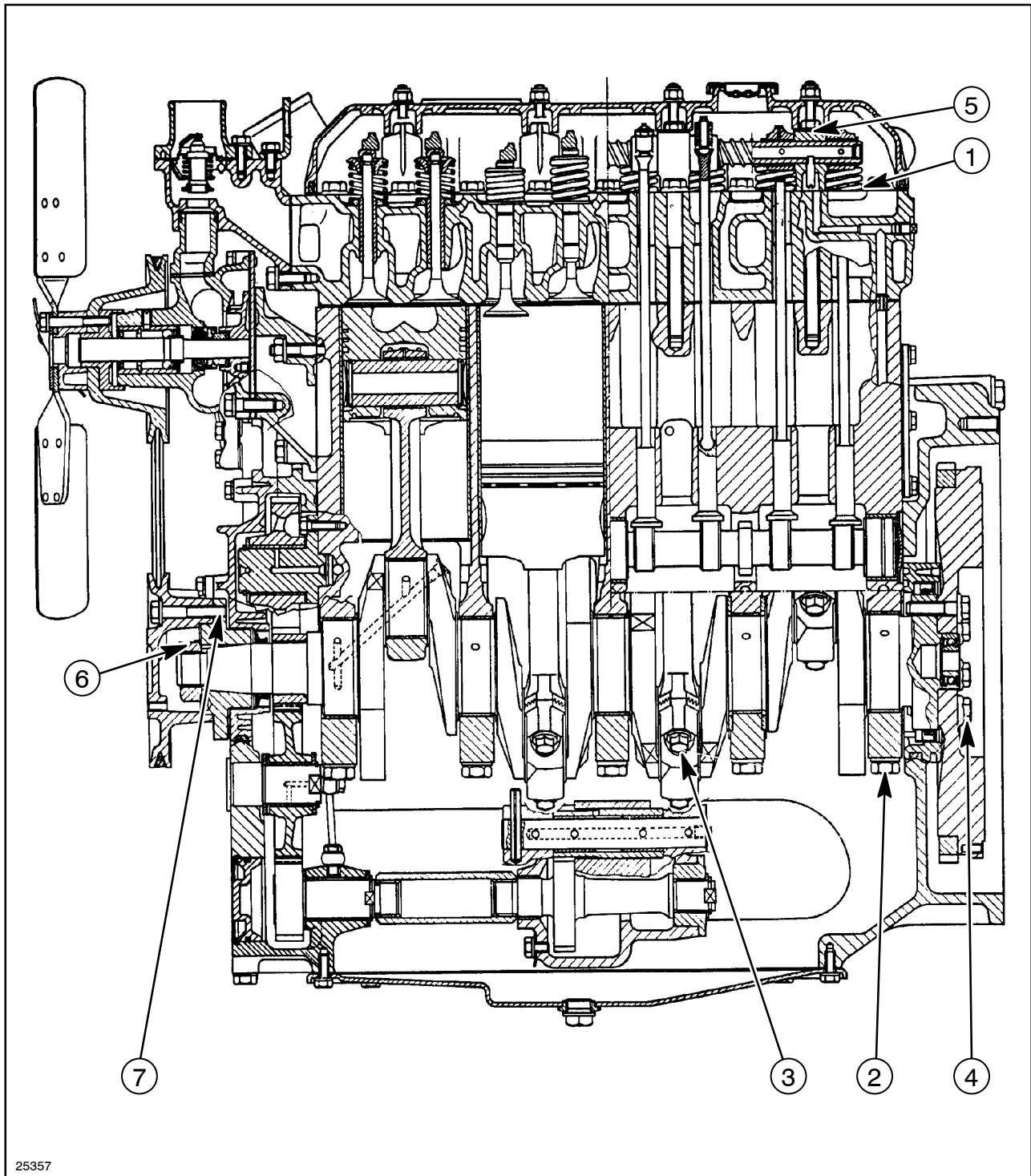

25357

7

Longitudinal View of 4-Cylinder Engine (JX80, JX90 and JX95)

- | | |
|----------------------------|------------------------------------|
| 1. Cylinder Head Bolts | 5. Rocker Shaft Pedestal Bolts |
| 2. Main Bearing Cap Bolts | 6. Crankshaft Hub Retaining Nut |
| 3. Big-end Cap Bolts | 7. Fan and Alternator Pulley Bolts |
| 4. Flywheel Mounting Bolts | |

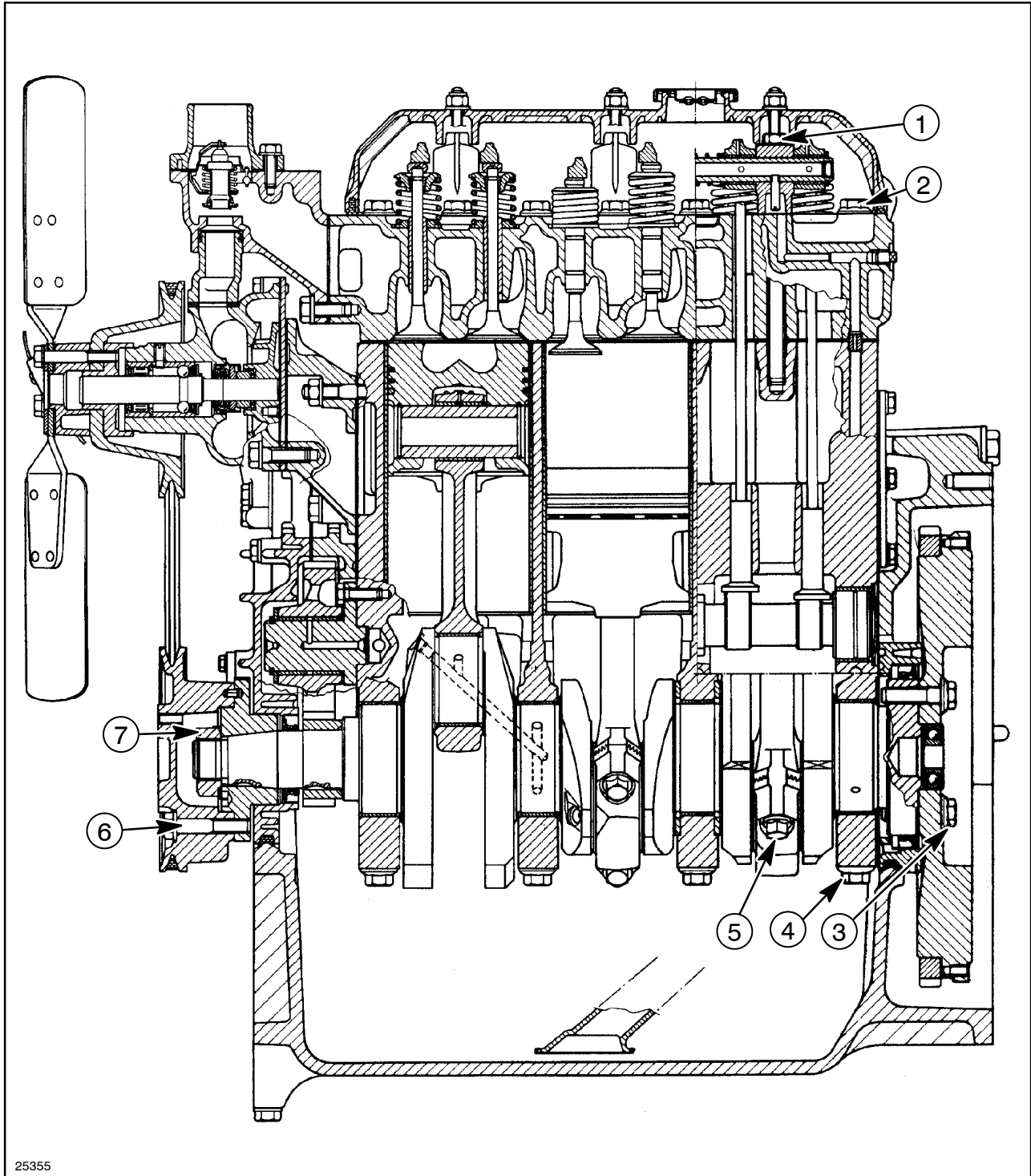

**Longitudinal View of 3-Cylinder Engine
(JX60 and JX70 models)**

1. Rocker shaft pedestal bolts
2. Cylinder head bolts
3. Flywheel mounting bolts
4. Main bearing cap bolts

5. Big-end cap bolts
6. Fan and alternator pulley bolts
7. Crankshaft hub retaining bolts

OVERHAUL

ENGINE

Removal

**DANGER**

Lift and handle all heavy parts using suitable lifting equipment.

Make sure that the load is supported by means of suitable slings and hooks.

Make sure that no-one is standing in the vicinity of the load to be lifted.

**WARNING**

Always use suitable tools to align holes in parts.
NEVER USE YOUR FINGERS OR HANDS.

1. Disconnect the battery negative (ground) and positive cables (1).
2. Drain oil from the transmission/gearbox.
3. Drain the cooling system.

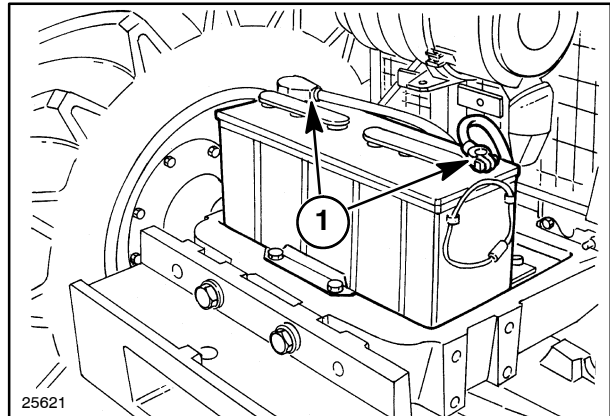

11

4. Unscrew the nut (1) from the front ballast retaining pin.

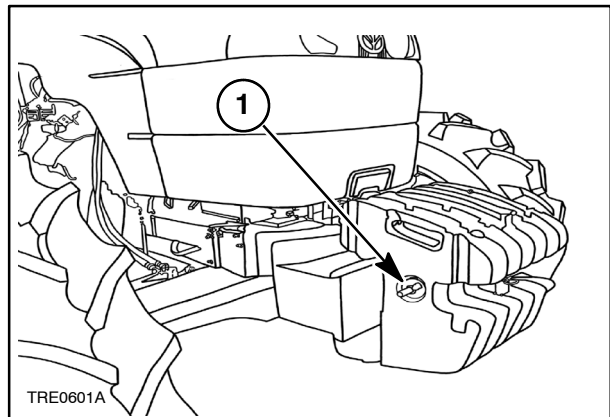

12

5. Remove the ballast (1) from the front support.

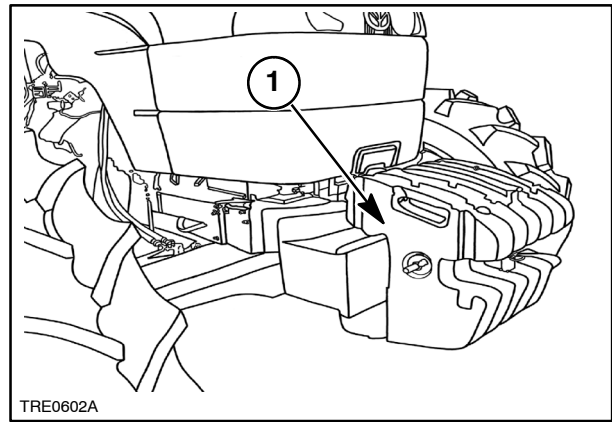

13

6. Remove the exhaust pipe. Attach lifting chains to the hood (1) using tools **50131** and **50132** and attach the chain to the hoist.

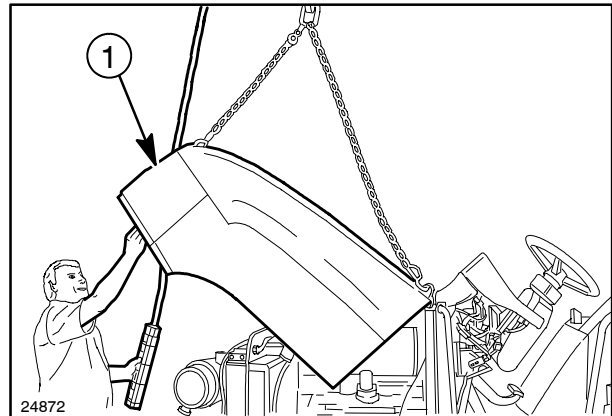

14

7. Detach the electrical leads (1) from the headlamps (2).

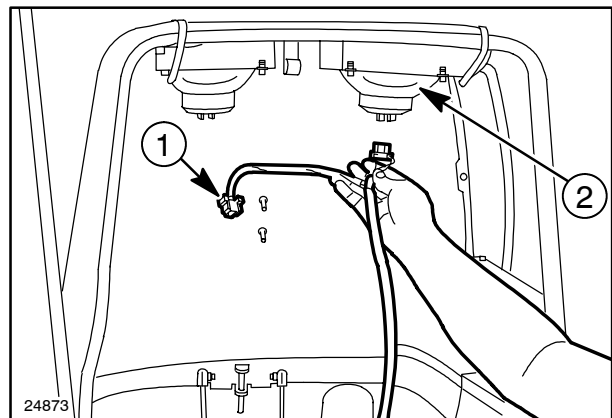

15

8. Detach the struts (1) from hood.

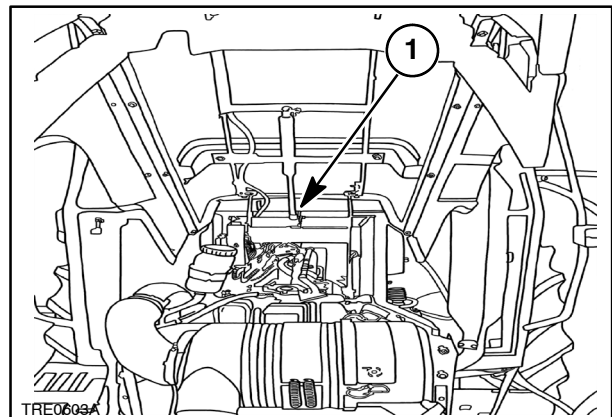

16

9. Remove the four hood hinge bolts (1) and lift the hood clear.

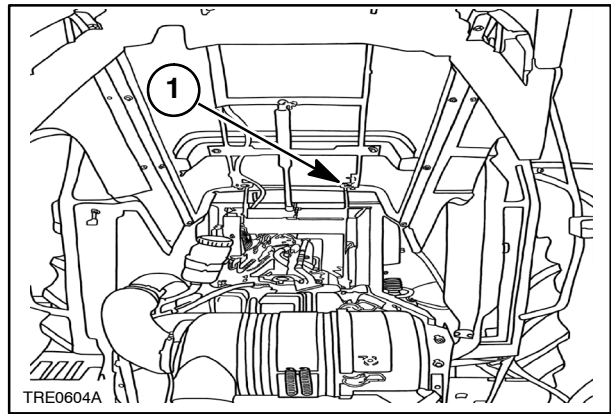

17

10. Remove the fan guard (1) from right-hand side of the fan.

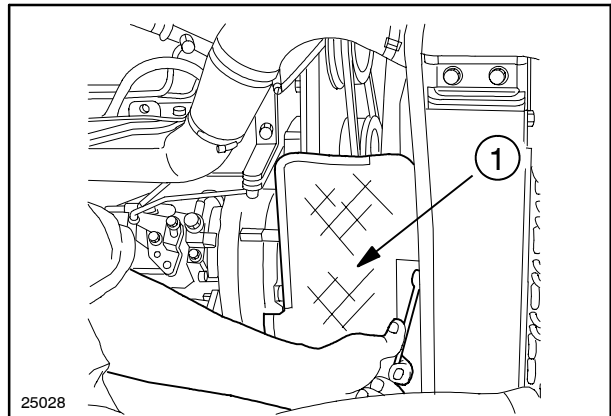

18

11. Disconnect the tachometer cable (1) and remove the retaining ring and sleeve.

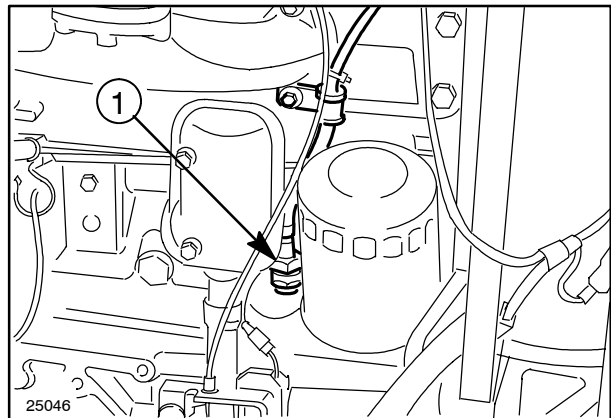

19

12. Detach the throttle control spring (1) and remove the throttle lever (2).

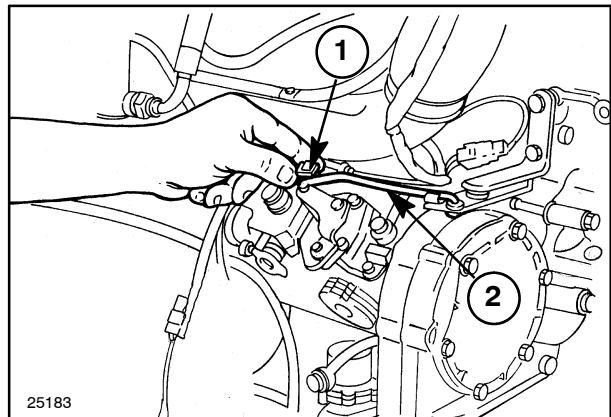

20

13. Detach the cab air-conditioning pipes (1) and (2) (if applicable).

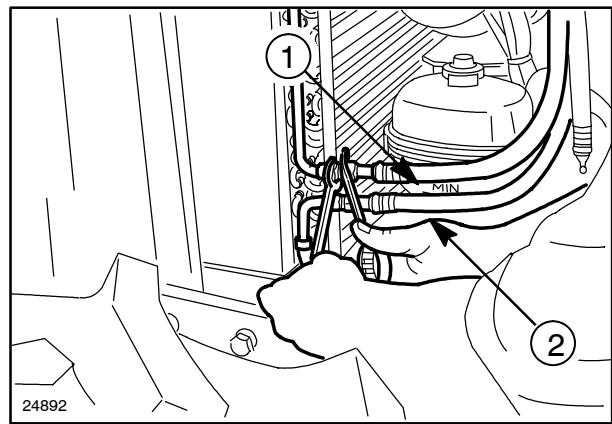

21

14. Detach the cab heating pipes (1) and (2) (if applicable).

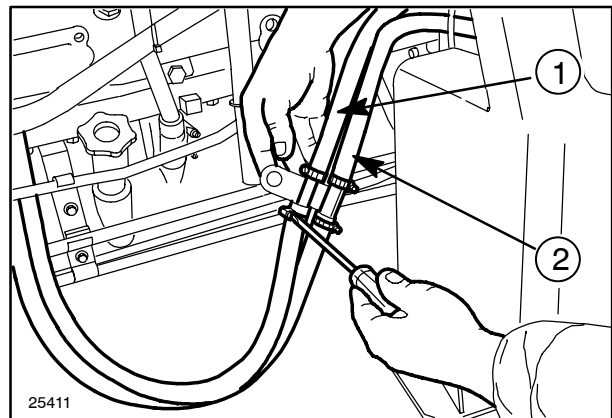

22

15. Disconnect the main harness electrical connectors.

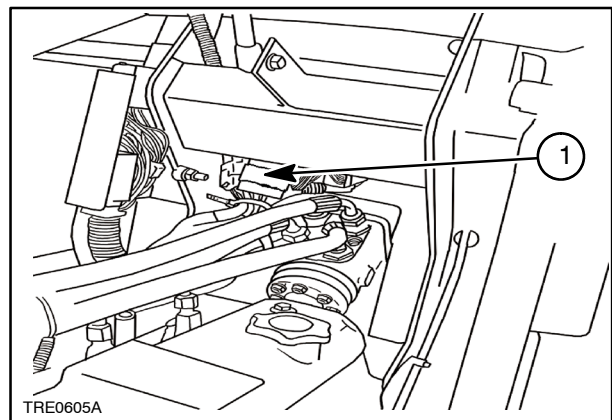

23

16. Remove the fusebox by unscrewing the nut (1)

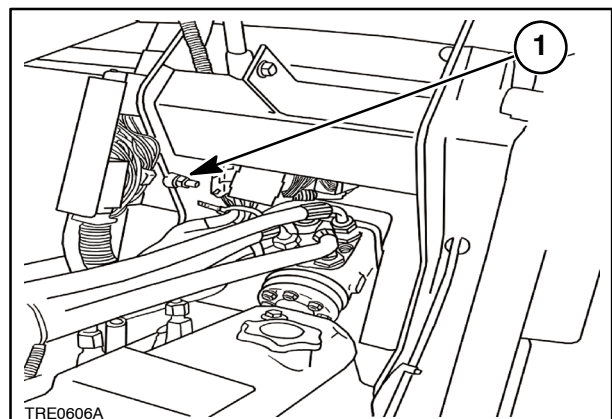

24

17. Disconnect the delivery and return lines (1) to the power steering cylinders.

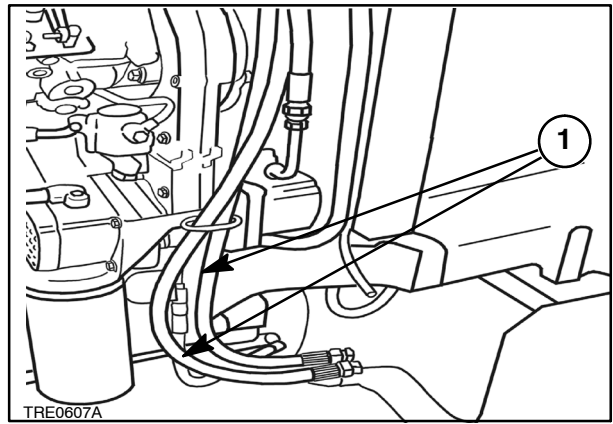

25

18. Remove the supply hose (1) from the lift pump.

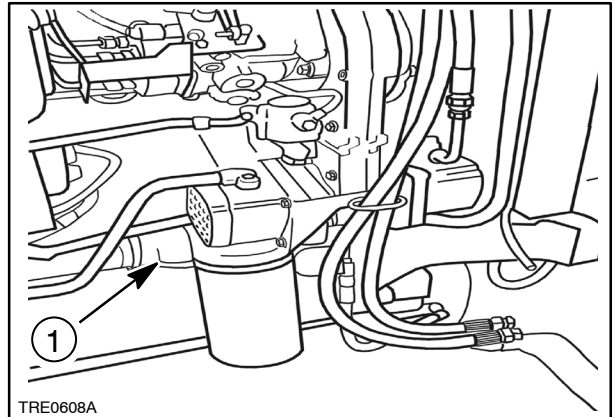

26

19. Detach the lift pump delivery pipe (1).

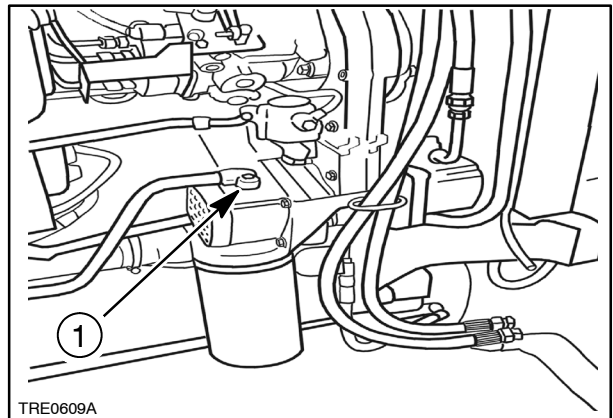

27

20. Detach the fuel pipes from the fuel injection pump and the pipe connecting the fuel tank to the fuel filter (1).

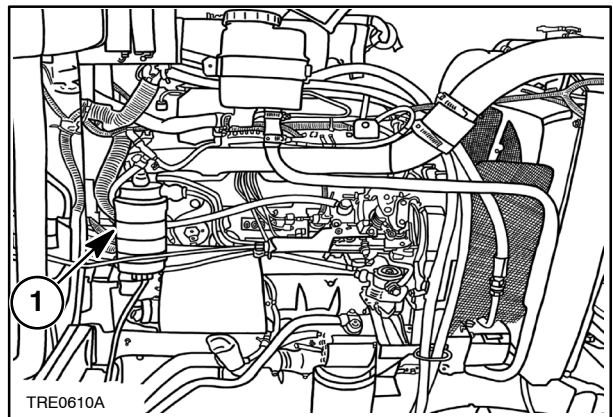

28

21. Remove the fuel filter (1) and support.

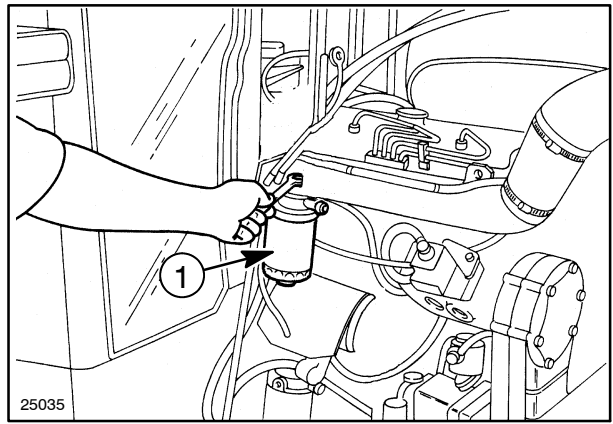

29

22. Remove the front, center and rear retaining bolts from the front axle drive shaft guard and remove the guard (models with MFD).

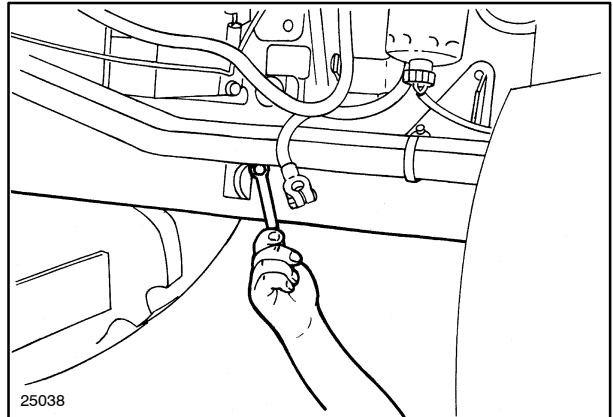

30

23. Remove the circlip (2) from the front of the drive shaft and slide the sleeve (1), in the direction shown by the arrow (see figure), until it is free of the splines on the front axle (models with MFD).

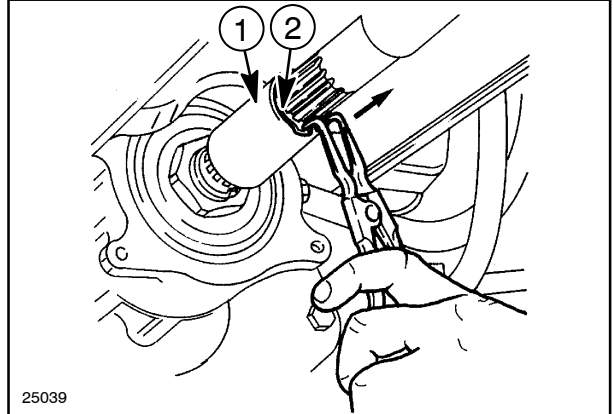

31

24. Remove the circlip (2) from the rear of the drive shaft and slide the sleeve (1), in the direction shown by the arrow (see figure), until it is free of the spines on the drive shaft (models with MFD).

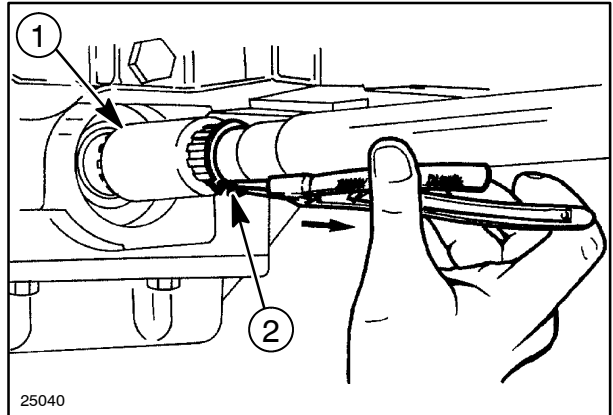

32

25. Remove the retaining bolts from the central drive shaft support (1) and remove the shaft complete with support (models with MFD).

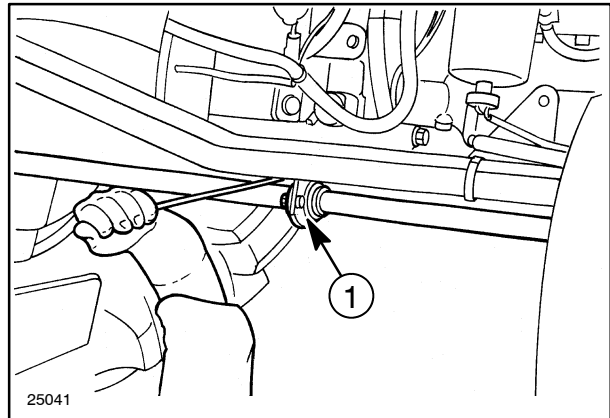

33

26. Withdraw the pin securing the differential lock knob (1), remove the knob and remove the mat from the floor.

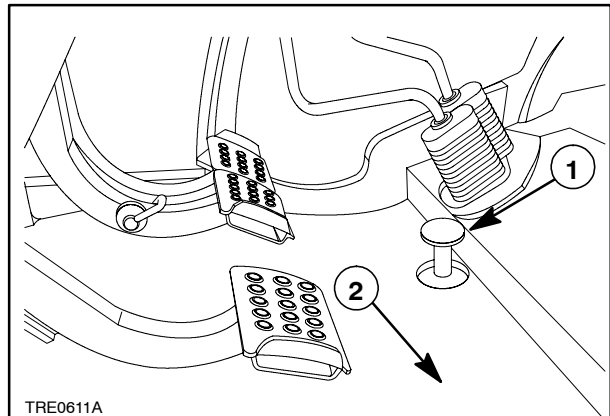

34

27. Unscrew the nuts (1) and the bolts securing the engine to the transmission. Access is through the two slots in the cab floor.

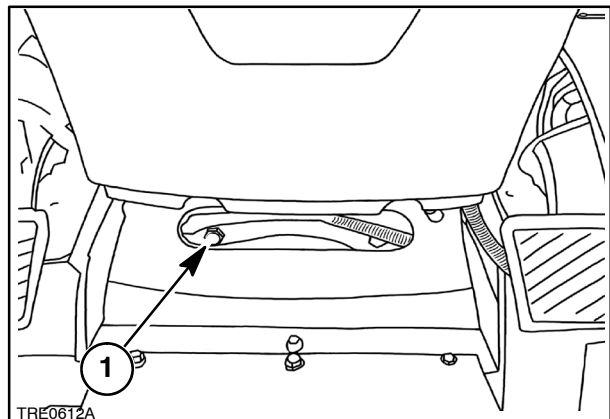

35

28. Unscrew the four lower bolts (1) securing the engine to the transmission.

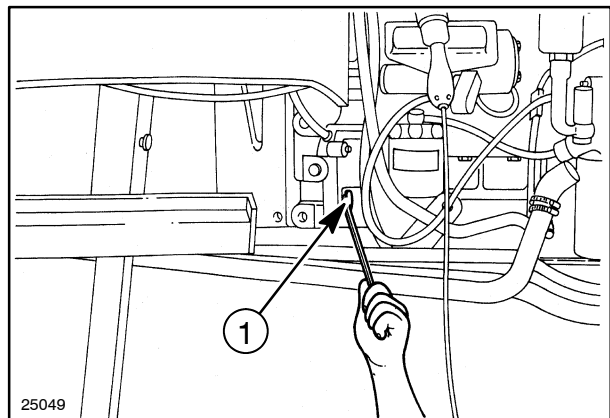

36

29. Position stand **380000236** underneath the tractor and insert a wedge (1), either side of the axle, to prevent the axle from pivoting.

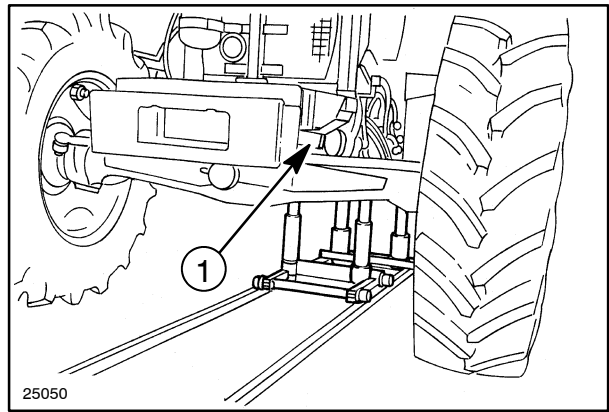

37

30. Insert a wooden block (1) between the stands and the tractor.

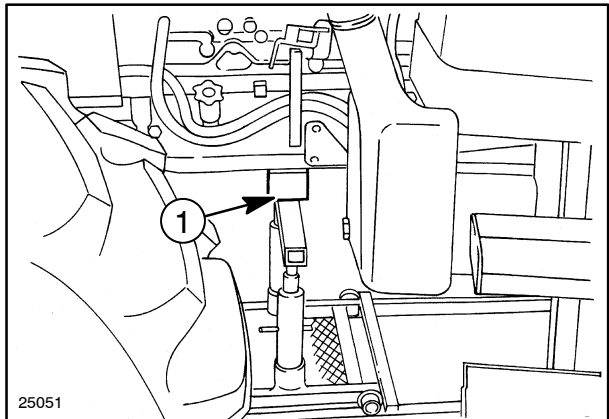

38

31. Place a fixed stand (1) underneath the drawbar support and apply the handbrake.

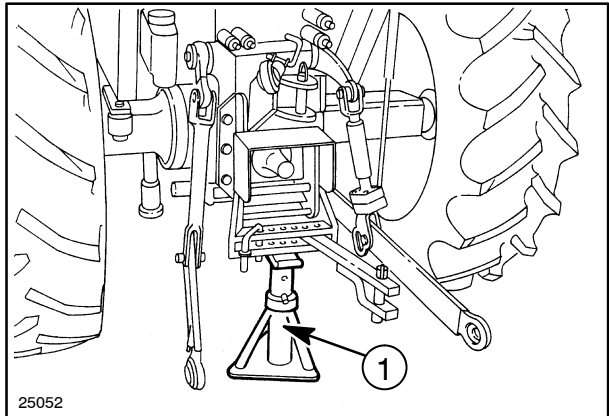

39

32. Unscrew the four remaining bolts securing the engine to the transmission.
 33. Separate the engine from the transmission.
 34. Remove the distance collar (1) between the engine and transmission.

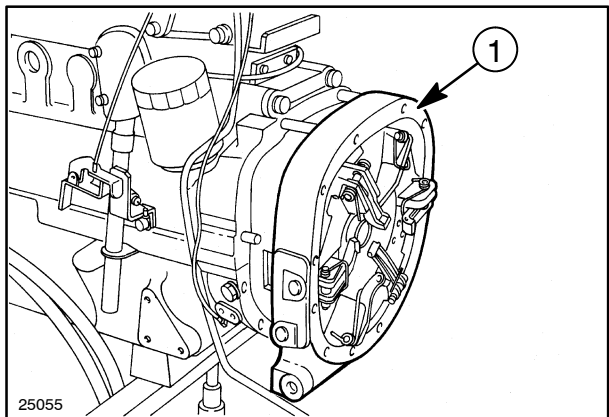

40

35. Place a fixed stand (1) underneath the front ballast support and chock the wheels with wooden wedges (2).

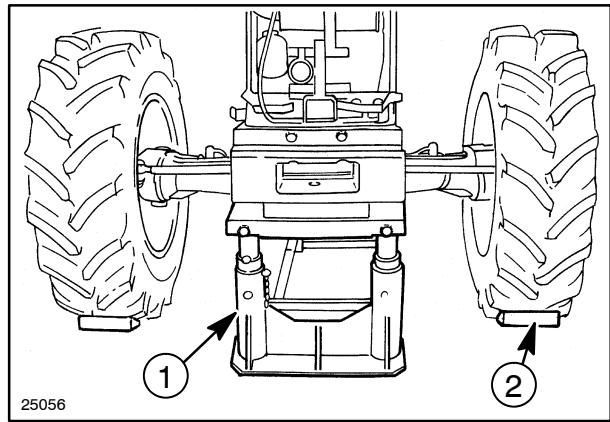

41

36. Insert tool **380000292** (1) in the clutch center hole. Unscrew the six bolts (2) securing the clutch to the flywheel and remove complete clutch assembly.

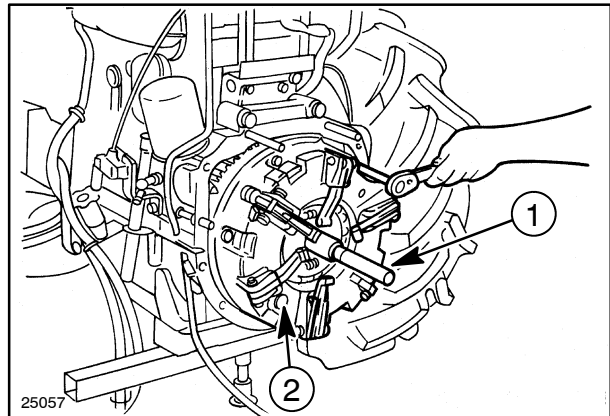

42

37. Remove the radiator support bracket (1).

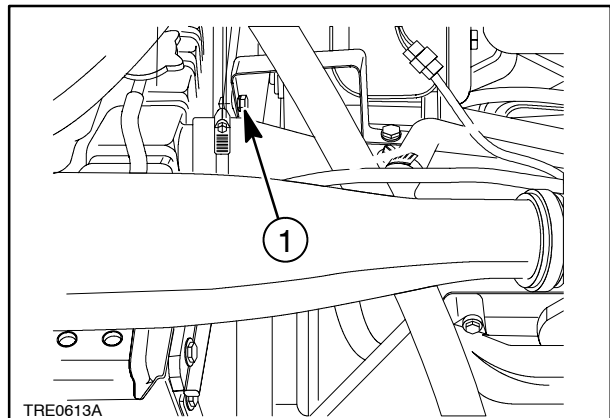

43

38. Attach the engine to the hoist using an adjustable chain (1) attached to the lifting points provided on the engine.

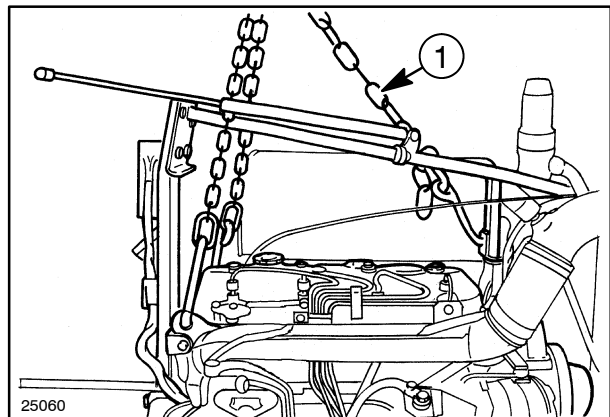

44

39. Remove the lift pump (1) complete with the filter by unscrewing the four retaining bolts.

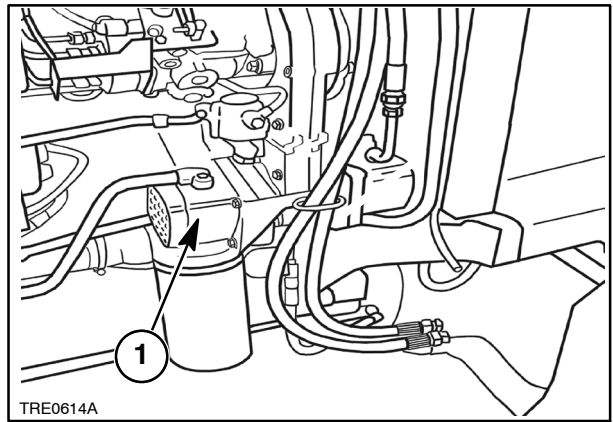

45

40. Disconnect all electrical connectors and remove the complete wiring harness (1).

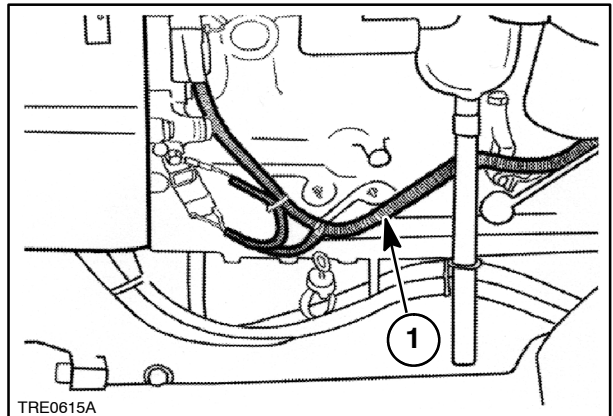

46

41. Loosen of the hose clamp and detach hose (1) from the inlet manifold.

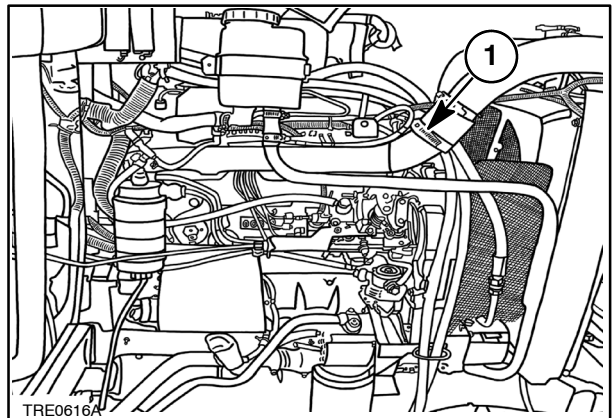

47

42. Remove the left-hand side fan guard (1).

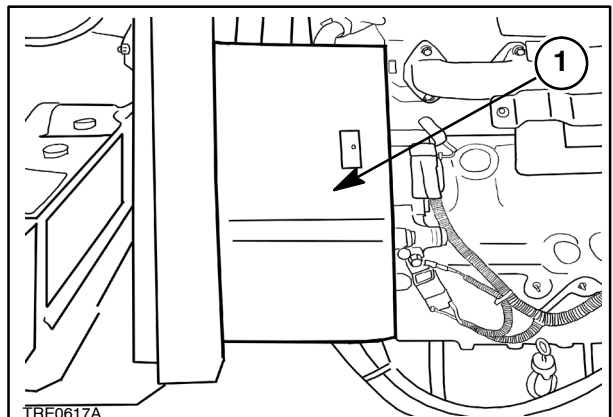

48

43. Unscrew the bolts (1) securing the muffler to the bracket.
44. Unscrew the three nuts securing the muffler (2) to the manifold and lift off the entire muffler assembly.

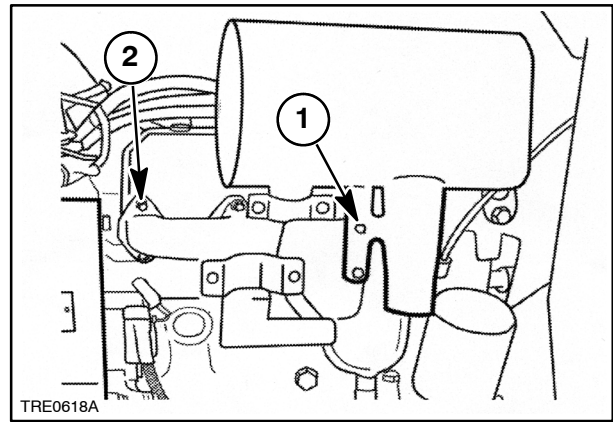

49

45. Remove the hose clamp and disconnect the top radiator hose (1).

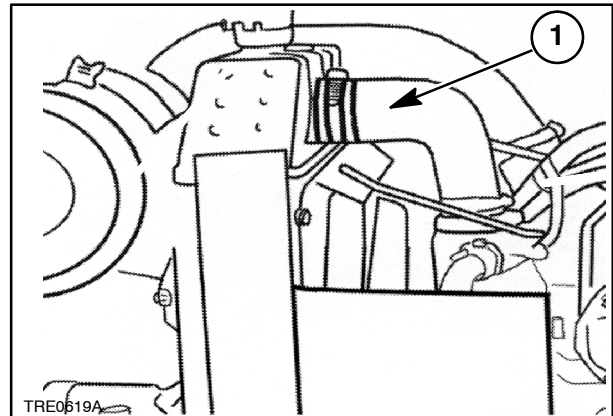

50

46. Using the hoist, raise the engine slightly and position the moveable stand (1) under the front axle.

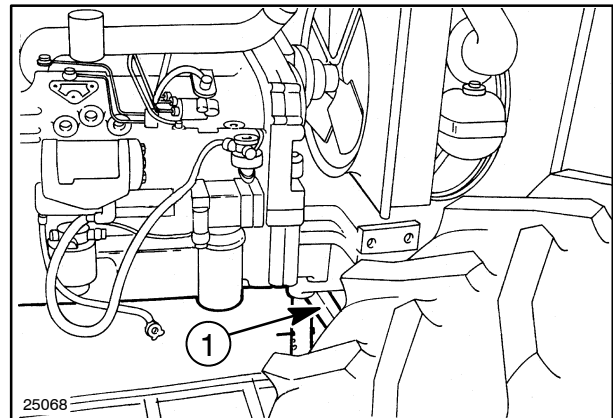

51

47. Remove the hose clamp and disconnect the bottom radiator hose (1).
48. Unscrew the four bolts (2) securing the engine to the front axle support, and lower the engine onto a wooden platform.

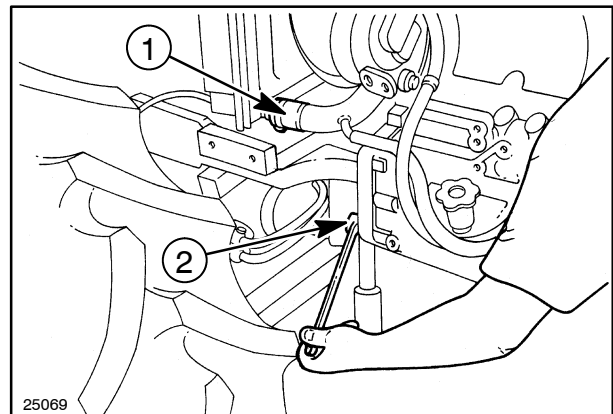

52

Installation

To install the engine, proceed as follows:

1. Attach the three hooks of an adjustable lifting chain to three eye bolts on the engine. Raise the engine from the platform and position it in front of the front axle support. Join the two units using the four securing bolts.
2. Move the mobile stand from under the front axle differential housing to under the engine sump, inserting a suitably shaped block of wood between the stand and the sump pan.
3. Attach the top radiator hose to the thermostat housing and secure with an adjustable hose clamp.
4. Connect the bottom radiator hose to the coolant pump and secure at both ends with adjustable hose clamps.
5. Install the lift pump.
6. Detach the lifting chain from the engine.
7. Connect the rigid pipe from the air cleaner to the inlet manifold and secure with the relative clamp.
8. Reconnect all electrical leads: thermostart glow plug, coolant temperature sensor, 'air filter blocked' sensor, horn, front axle support ground, engine stop on injection pump, leads to the alternator and relay, oil pressure sensor, starter motor, fuel dryer filter. Secure all leads with plastic ties.
9. Install the clutch to the engine flywheel using the six retaining bolts.
10. Connect the oil delivery pipe to the DT control valve. Tighten the pipe union on the anti-cavitation accumulator; install the bracket on the left-hand side near the engine oil filter.
11. Clean the distance collar and the mating surfaces of the overdrive clutch housing; scrape away all traces of old sealing compound.
12. Apply silicone sealing compound to the mating surfaces of engine and distance collar. Install the distance ring on the engine studs.
13. Apply silicone sealing compound to the mating surfaces of the overdrive clutch housing.
14. Remove the fixed stand from under the front weight support. Remove the wooden wedges from under the front wheels.
15. Attach the adjustable lifting chain to the eyebolts on the engine.
16. Place wooden wedges under the rear wheels, check that the handbrake is fully on and that the fixed and moveable stands are firmly in place.
17. Detach the lifting chain from the engine. Attach the two cables still attached to the cab handrail to the hook of the hoist. Raise the front part of the cab about 6 cm. (2.36 in.)
18. Replace and tighten all the bolts securing the engine to the overdrive clutch housing.
19. Bolt on the brake pipe support bracket on the right-hand side of the engine. Lower the hoist and detach the cables from the cab handrail.
20. Lower the stands under the engine sump and the clutch housing. Remove tool **380000236** and the stand from under the drawbar support.
21. Fix the cab in place with the two front securing bolts.
22. Connect the injector leak-off pipe. Connect the pipes to the glowplug and to the fuel dryer filter.
23. Install the fuel filter mounting to the engine. Connect the two semirigid pipes to the mounting.
24. Connect the oil suction pipes to the pumps; secure the rubber hoses with hose clamps.
25. Connect the lift control valve supply pipe to the lift pump with a new O-ring.
26. Secure the three pipes with the adjustable hose clamp.
27. Attach all the electrical leads to the connectors on the vertical support bracket.
28. Install the cab heater pipe union on the engine/clutch distance collar. Connect the rubber heater hoses to the union.

- 29.** Connect the two flexible power steering pipes to the union on the left-hand side of the front axle. Secure the two pipes with a special clamp and fix the clamp to the tractor with a screw.
- 30.** Install the tachometer cable and secure the sleeve with the retaining ring.
- 31.** Install the muffler onto the exhaust manifold with a new gas seal. Fix the front of the muffler to the vertical support bracket. Attach the flexible Donaspin pipe.
- 32.** Attach the support bracket to the radiator.
- 33.** Install the FWD transmission shaft and the guard.
- 34.** Connect the throttle cable to the accelerator pedal. It may be necessary to adjust the cable at the injection pump lever end.
- 35.** Install the clutch cable to the clutch pedal. Fix the sleeve to the travel stop.
- 36.** Replace the plastic plugs in the holes in the cab floor. Replace the mat.
- 37.** Install the steering column cover panels.
- 38.** Replace the fan guards.
- 39.** Attach slings to the hood in the manner described previously in the engine removal instructions. Screw the hood hinge to its bracket. Attach the gas strut, the electrical leads to the headlamps, and then remove the slings.
- 40.** Install the secondary bracket (battery support) to the overdrive clutch housing. Install the rotating bracket with the battery on the fixed support.
- 41.** Install the front ballast and secure with the lock pin.
- 42.** Install the tool box support bracket and then the tool box.
- 43.** Fill the transmission/gearbox with oil (refer to Section 00).
- 44.** Fill the radiator with coolant mixture (refer to Section 00).
- 45.** Connect the positive and negative battery leads. Install the plastic battery cover.

Disassembly

**CAUTION**

Handle all parts carefully. Do not put your hands or fingers between parts.
Wear suitable safety clothing - safety goggles, gloves and shoes.

1. Remove the front and rear retaining screws from the hood stay bracket (1).
2. Remove the hood catch support side retaining bolts (1) and rear retaining bolts (2). Remove the hood catch and stay bracket.
3. Loosen the alternator pivot bolt.
4. Loosen the belt tension adjustment bolt (1).
5. Release the belt tension adjustment arm by unscrewing the retaining nut.
6. Remove the alternator and coolant pump drive belt.
7. Unscrew the bolts securing the fan (1) and pulley to the coolant pump. Remove the fan and pulley.

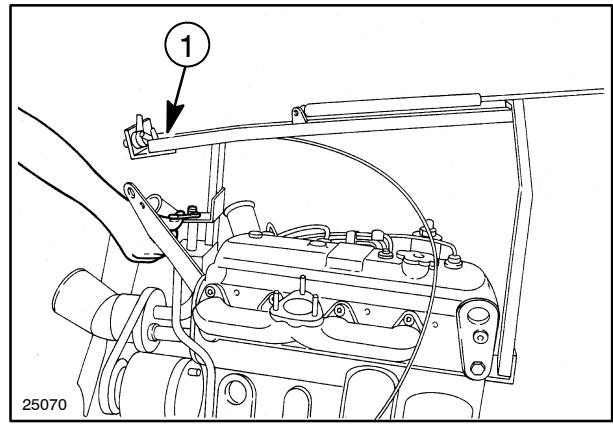

53

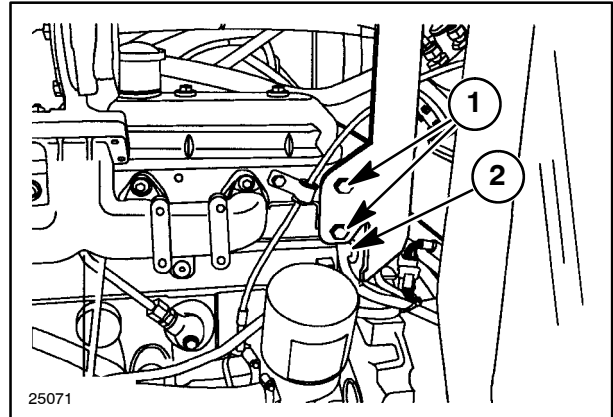

54

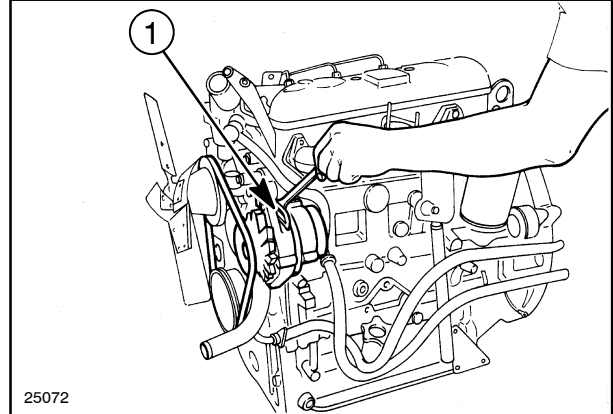

55

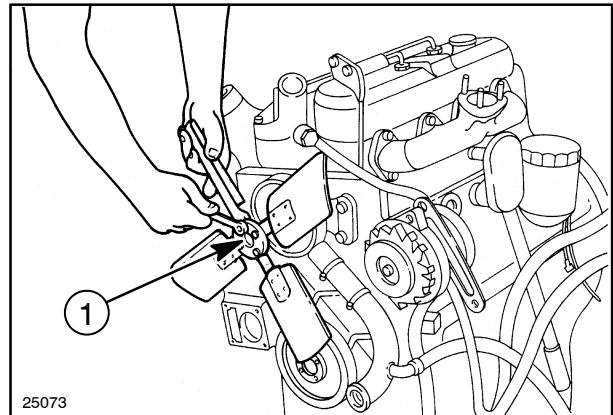

56

8. Unscrew the union (1) from the water supply pipe to the cab heater.

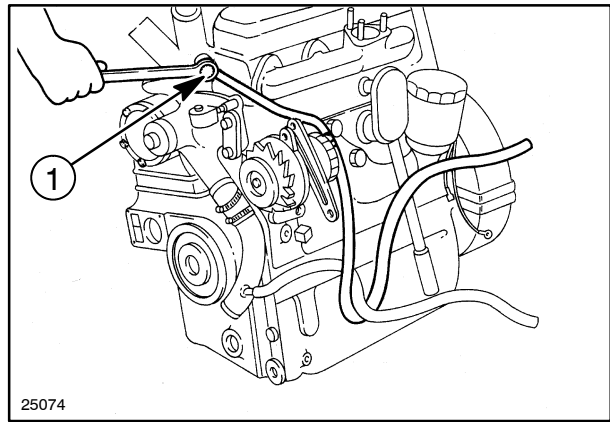

57

9. Loosen the hose clamp (1) and detach the hose from the coolant pump. Remove the curved hose and flexible cab heater hoses.

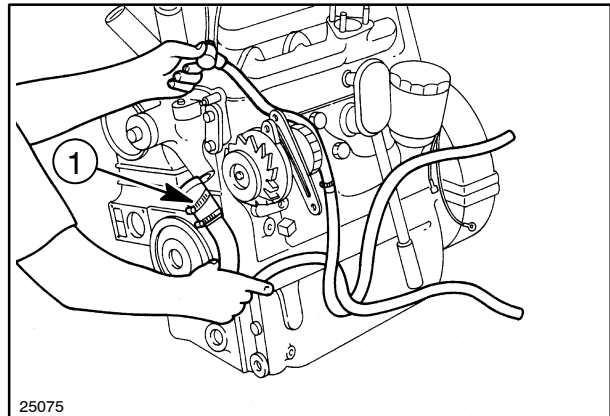

58

10. Remove the union (1) in order to gain access to the pump retaining bolt.

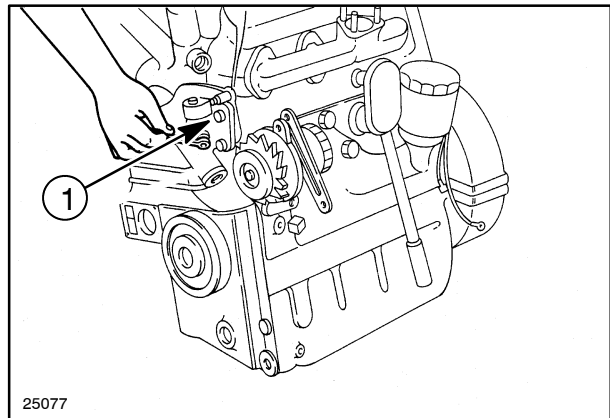

59

11. Unscrew the coolant pump retaining bolts (1) and remove the pump.

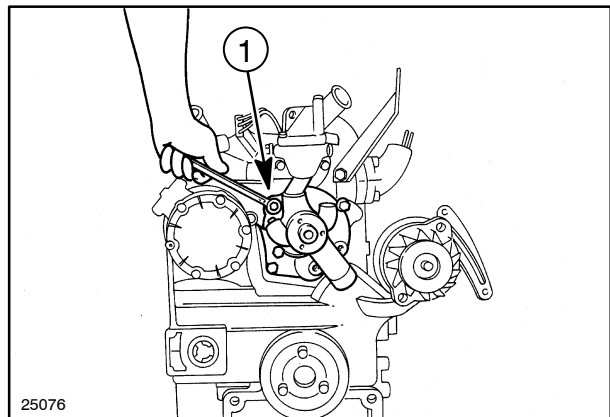

60

12. Unscrew the pump support bolts (1) and the muffler support bolt. Remove the two supports.

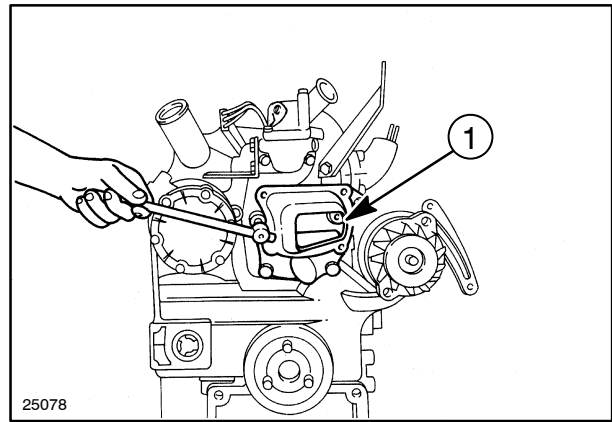

61

13. Install mounting bracket (1) of the set **380000313** to permit attachment of the engine to the rotary stand **380000301**.

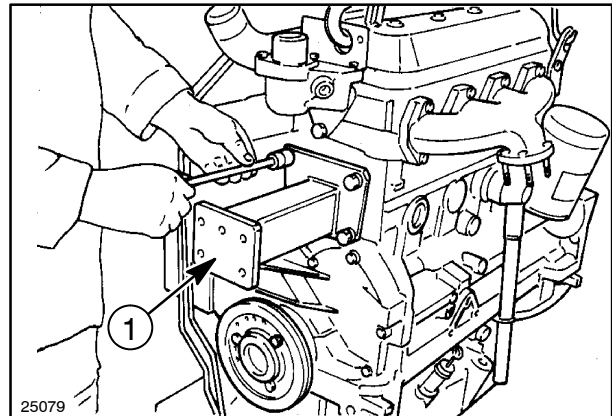

62

14. Install an eyebolt (1) on the front of the engine in place of the muffler support.
15. Raise the engine from the wooden platform and secure it to rotary stand **380000301** (2) by means of the bracket (3) from the set **380000313**.

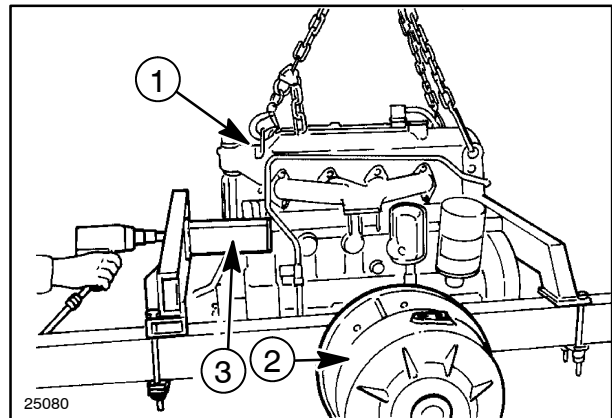

63

16. Remove the alternator support retaining bolts (1) and remove the complete alternator assembly.

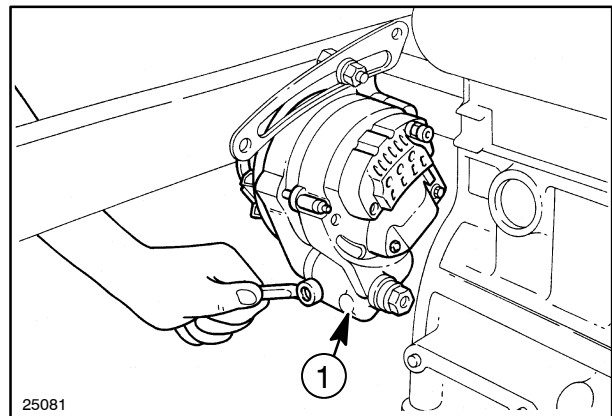

64

17. Unscrew the bolts (1) securing the exhaust manifold to the cylinder head and remove the manifold.

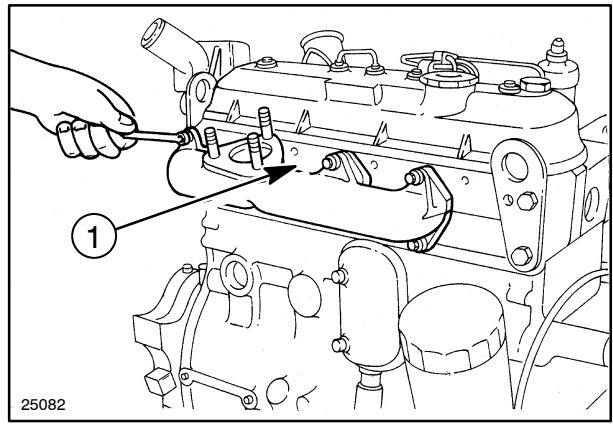

65

18. Detach the throttle control lever (1) from the injection pump.

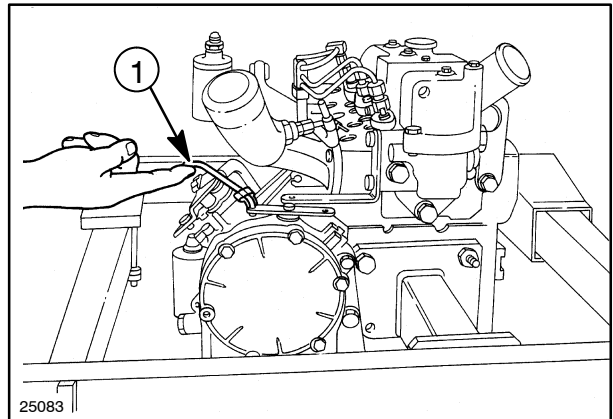

66

19. Remove the thermostat housing retaining bolts (1) and remove the thermostat housing.

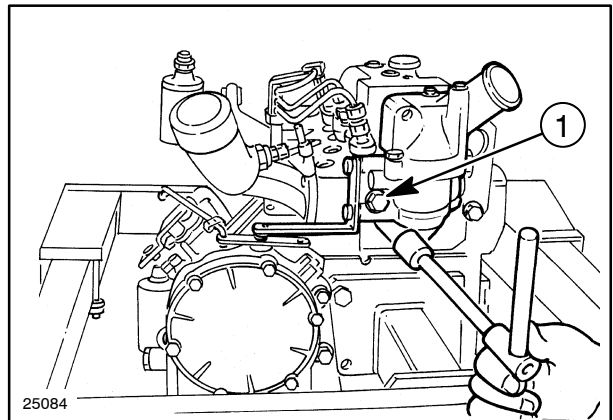

67

20. Unscrew the high pressure fuel line unions (1) on the injection pump and remove the fuel lines.

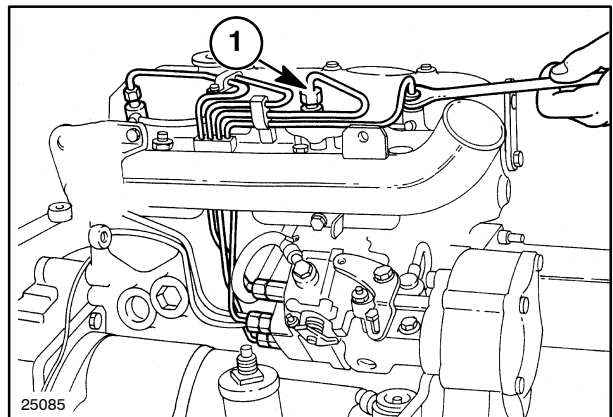

68

21. Unscrew the bolts (1) securing the inlet manifold to the cylinder head and remove the manifold.

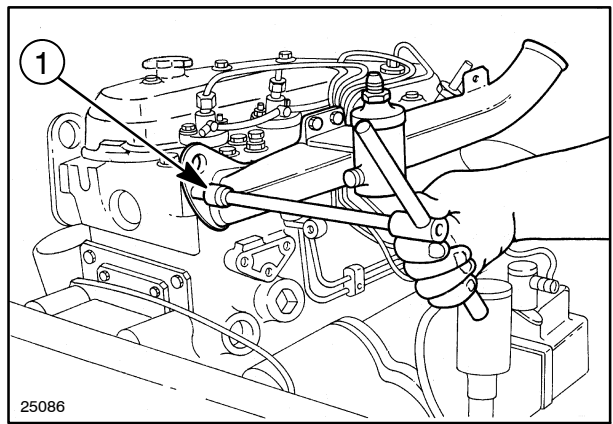

69

22. Remove the pipes and unions (1) to the fuel supply pump.

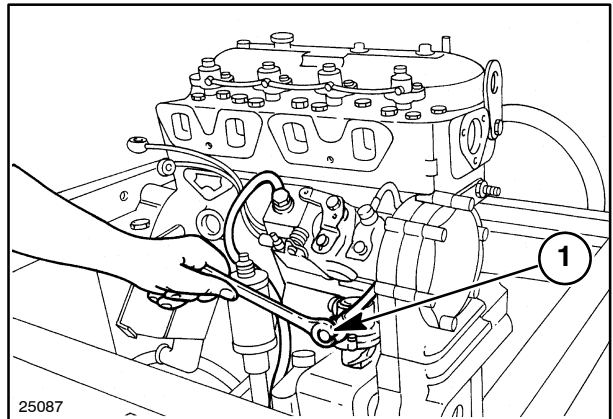

70

23. Unscrew the nuts (1) securing the injection pump to the timing gear case.

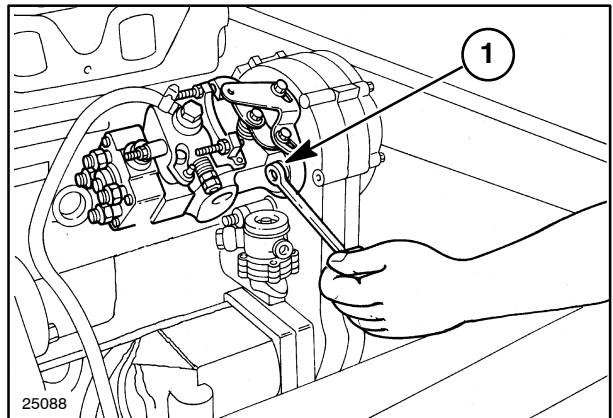

71

24. Remove bolts (1) and the injection pump drive gear cover.

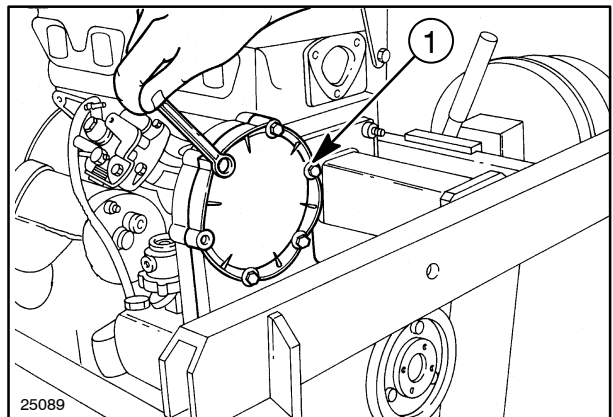

72



Suggest:

If the above button click is invalid.

Please download this document

first, and then click the above link

to download the complete manual.

Thank you so much for reading

25. Unscrew the nut (1) securing the injection pump shaft to the drive gear.

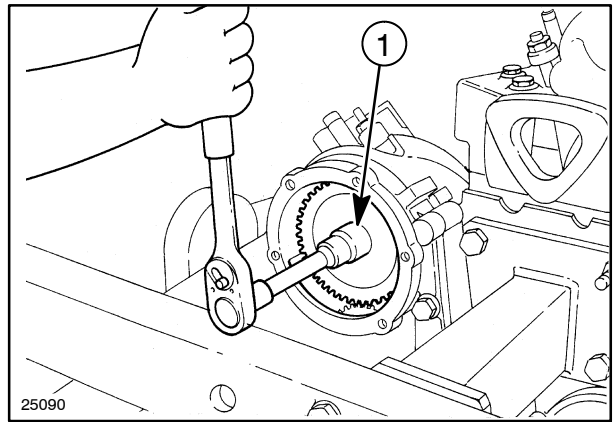

73

26. Remove the injection pump drive gear using tool **380000835** (1) and remove the injection pump and the woodruff key.

NOTE: See "Injection Pump" removal in Chapter 4 prior to removing fuel injector pump. Fuel injector pump must be lock timed prior to removing from the engine.

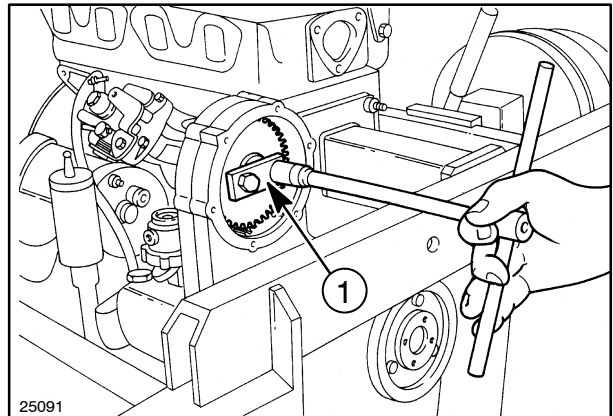

74

27. Remove the fuel line unions (1) on the fuel filter.

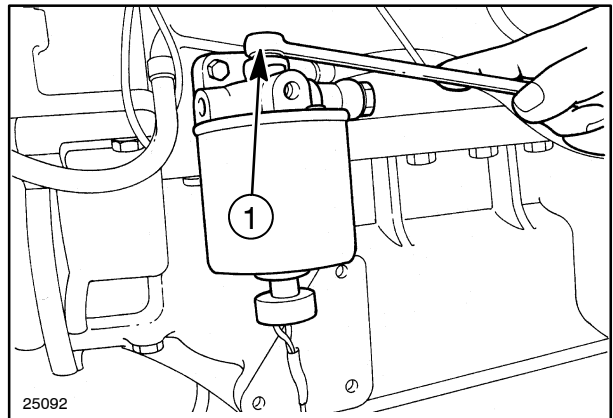

75

28. Unscrew the bolts securing the fuel filter support to the engine block and remove the complete filter assembly.

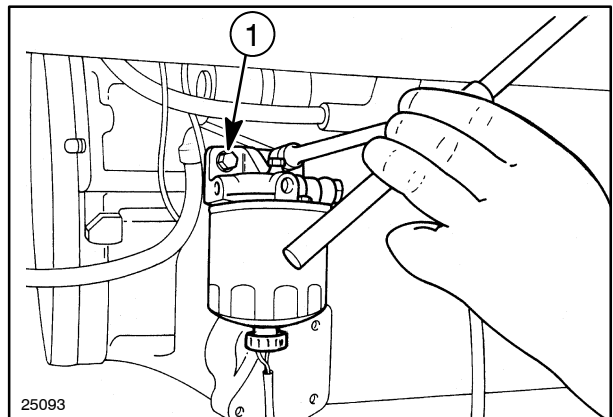

76

<https://www.ebooklibonline.com>

Hello dear friend!

Thank you very much for reading.

Enter the link into your browser.

The full manual is available for immediate download.

<https://www.ebooklibonline.com>