

FARMALL® I10U
FARMALL® I20U
Tier 4B (final)
Tractor

SERVICE MANUAL

Part number 51487919

1st edition English

July 2018





SERVICE MANUAL

Farmall® 110U With 16x16 Semi-Powershift transmission
Farmall® 120U With 16x16 Semi-Powershift transmission

Link Product / Engine

Product	Market Product	Engine
Farmall® 110U With 16x16 Semi-Powershift transmission	North America	F5GFL413V*C001
Farmall® 120U With 16x16 Semi-Powershift transmission	North America	F5GFL413U*C002

<https://www.ebooklibonline.com>

Hello dear friend!

Thank you very much for reading.

Enter the link into your browser.

The full manual is available for immediate download.

<https://www.ebooklibonline.com>

Contents

INTRODUCTION

Engine	10
[10.001] Engine and crankcase	10.1
[10.216] Fuel tanks	10.2
[10.206] Fuel filters	10.3
[10.202] Air cleaners and lines	10.4
[10.254] Intake and exhaust manifolds and muffler	10.5
[10.500] Selective Catalytic Reduction (SCR) exhaust treatment.....	10.6
[10.501] Exhaust Gas Recirculation (EGR) exhaust treatment.....	10.7
[10.400] Engine cooling system	10.8
[10.414] Fan and drive	10.9
[10.310] Aftercooler.....	10.10
[10.218] Fuel injection system.....	10.11
Clutch	18
[18.100] Clutch mechanical release control	18.1
[18.112] Slip clutch or flywheel damper	18.2
Transmission	21
[21.111] Semi-Powershift transmission	21.1
[21.133] Semi-Powershift transmission external controls	21.2
[21.103] Semi-Powershift transmission hydraulic components.....	21.3
[21.152] Semi-Powershift transmission internal components	21.4
[21.160] Creeper	21.5
[21.109] Transmission cooler and lines.....	21.6
Four-Wheel Drive (4WD) system	23
[23.202] Electro-hydraulic control	23.1
[23.314] Drive shaft.....	23.2

Front axle system	25
[25.100] Powered front axle	25.1
[25.102] Front bevel gear set and differential	25.2
[25.108] Final drive hub, steering knuckles, and shafts	25.3
[25.122] Axle suspension control	25.4
Rear axle system.....	27
[27.100] Powered rear axle.....	27.1
[27.106] Rear bevel gear set and differential.....	27.2
[27.120] Planetary and final drives	27.3
Power Take-Off (PTO).....	31
[31.104] Rear electro-hydraulic control.....	31.1
[31.114] Two-speed rear Power Take-Off (PTO)	31.2
[31.116] Three-speed rear Power Take-Off (PTO)	31.3
[31.142] Front Power Take-Off (PTO) control	31.4
[31.146] Front Power Take-Off (PTO)	31.5
Brakes and controls	33
[33.202] Hydraulic service brakes	33.1
[33.110] Parking brake or parking lock	33.2
[33.220] Trailer brake hydraulic control.....	33.3
[33.224] Trailer brake pneumatic control	33.4
Hydraulic systems.....	35
[35.000] Hydraulic systems.....	35.1
[35.304] Combination pump units	35.2
[35.322] Regulated/Low pressure system	35.3
[35.204] Remote control valves	35.4
[35.100] Main lift system.....	35.5
[35.114] Three-point hitch control valve	35.6
[35.116] Three-point hitch cylinder	35.7

[35.160] Front hitch controls and lines	35.8
[35.162] Front hitch cylinders and lines	35.9
[35.300] Reservoir, cooler, and filters.....	35.10
[35.350] Safety and main relief valves	35.11
Hitches, drawbars, and implement couplings.....	37
[37.100] Drawbars and towing hitches	37.1
[37.110] Rear three-point hitch	37.2
[37.120] Rear three-point hitch linkage.....	37.3
[37.162] Front hitch.....	37.4
[37.166] Front hitch linkage.....	37.5
Frames and ballasting	39
[39.140] Ballasts and supports	39.1
Steering.....	41
[41.101] Steering control	41.1
[41.106] Tie rods.....	41.2
[41.200] Hydraulic control components.....	41.3
[41.216] Cylinders	41.4
Wheels	44
[44.511] Front wheels.....	44.1
[44.520] Rear wheels.....	44.2
Cab climate control	50
[50.100] Heating	50.1
[50.104] Ventilation	50.2
[50.200] Air conditioning.....	50.3
Electrical systems	55
[55.100] Harnesses and connectors.....	55.1
[55.525] Cab engine controls.....	55.2

[55.015] Engine control system..... 55.3

[55.201] Engine starting system..... 55.4

[55.301] Alternator..... 55.5

[55.302] Battery..... 55.6

[55.202] Cold start aid..... 55.7

[55.011] Fuel tank system..... 55.8

[55.010] Fuel injection system..... 55.9

[55.014] Engine intake and exhaust system..... 55.10

[55.988] Selective Catalytic Reduction (SCR) electrical system..... 55.11

[55.989] Exhaust Gas Recirculation (EGR) electrical system..... 55.12

[55.012] Engine cooling system..... 55.13

[55.013] Engine oil system..... 55.14

[55.640] Electronic modules..... 55.15

[55.513] Cab transmission controls..... 55.16

[55.024] Transmission control system..... 55.17

[55.020] Transmission speed sensors..... 55.18

[55.021] Transmission pressure sensors and switches..... 55.19

[55.022] Transmission temperature sensors..... 55.20

[55.040] Four-Wheel Drive (4WD) control system..... 55.21

[55.045] Front axle control system..... 55.22

[55.046] Rear axle control system..... 55.23

[55.522] Cab Power Take-Off (PTO) controls..... 55.24

[55.048] Rear Power Take-Off (PTO) control system..... 55.25

[55.049] Front Power Take-Off (PTO) control system..... 55.26

[55.519] Cab brake controls..... 55.27

[55.031] Parking brake electrical system..... 55.28

[55.032] Trailer brake electrical system..... 55.29

[55.512] Cab controls..... 55.30

[55.035] Remote control valve electric control..... 55.31

[55.051] Cab Heating, Ventilation, and Air-Conditioning (HVAC) controls.....	55.32
[55.050] Heating, Ventilation, and Air-Conditioning (HVAC) control system.....	55.33
[55.523] Cab hitch controls	55.34
[55.130] Rear three-point hitch electronic control system	55.35
[55.785] Precision farming system	55.36
[55.911] Satellite navigation systems.....	55.37
[55.680] Autopilot/Autoguidance	55.38
[55.518] Wiper and washer system.....	55.39
[55.404] External lighting	55.40
[55.405] External lighting switches and relays	55.41
[55.408] Warning indicators, alarms, and instruments	55.42
[55.905] ISOBUS components	55.43
[55.DTC] FAULT CODES.....	55.44
Front loader and bucket.....	82
[82.100] Arm.....	82.1
Accessories	88
[88.100] Accessories	88.1
Platform, cab, bodywork, and decals.....	90
[90.150] Cab.....	90.1
[90.151] Cab interior.....	90.2
[90.160] Cab interior trim and panels.....	90.3
[90.154] Cab doors and hatches	90.4
[90.156] Cab windshield and windows	90.5
[90.118] Protections and footboards.....	90.6
[90.120] Mechanically-adjusted operator seat.....	90.7
[90.124] Pneumatically-adjusted operator seat.....	90.8
[90.100] Engine hood and panels	90.9
[90.102] Engine shields, hood latches, and trims	90.10

[90.116] Fenders and guards 90.11



INTRODUCTION

Foreword - Important notice regarding equipment servicing

All repair and maintenance work listed in this manual must be carried out only by qualified dealership personnel, strictly complying with the instructions given, and using, whenever possible, the special tools.

Anyone who performs repair and maintenance operations without complying with the procedures provided herein shall be responsible for any subsequent damages.

The manufacturer and all the organizations of its distribution chain, including - without limitation - national, regional, or local dealers, reject any responsibility for damages caused by parts and/or components not approved by the manufacturer, including those used for the servicing or repair of the product manufactured or marketed by the manufacturer. In any case, no warranty is given or attributed on the product manufactured or marketed by the manufacturer in case of damages caused by parts and/or components not approved by the manufacturer.

The manufacturer reserves the right to make improvements in design and changes in specifications at any time without notice and without incurring any obligation to install them on units previously sold. Specifications, descriptions, and illustrative material herein are as accurate as known at time of publication but are subject to change without notice.

In case of questions, refer to your CASE IH Sales and Service Networks.

Note to the Owner WARNINGS FOR AIR CONDITIONING SYSTEM REPAIR OPERATIONS

Starting the system at low temperatures can damage the compressor. Only operate the air conditioner when the engine is hot and the temperature inside the cab is at least **20 °C (68.00 °F)**.

When disconnecting the hoses, close the ends with plastic caps to prevent foreign matter and humidity from getting inside the hoses.

Handle the thermostatic sensor carefully to avoid damage that may prevent efficient system operation.

Always use two spanners to unscrew the hose fittings to avoid twisting the fitting.

Do not use any type of engine oil to lubricate the compressor and the system.

Never leave the compressor oil container open, always make sure that it is tightly closed. If left exposed the oil will absorb humidity from the air and may, subsequently, damage the system.

Do not transfer compressor oil from the original container to another container.

Do not introduce any additives to the compressor oil. Any additional substances could contain elements which are incompatible with the chemical base of the refrigerant and thus alter its characteristics.

Check that the thermostatic sensor is correctly inserted in the fins on the evaporator to ensure efficient system operation.

Safety rules

Personal safety





This is the safety alert symbol. It is used to alert you to potential personal injury hazards. Obey all safety messages that follow this symbol to avoid possible death or injury.

Throughout this manual you will find the signal words DANGER, WARNING, and CAUTION followed by special instructions. These precautions are intended for the personal safety of you and those working with you.

Read and understand all the safety messages in this manual before you operate or service the machine.

 DANGER indicates a hazardous situation that, if not avoided, will result in death or serious injury.

 WARNING indicates a hazardous situation that, if not avoided, could result in death or serious injury.

 CAUTION indicates a hazardous situation that, if not avoided, could result in minor or moderate injury.

FAILURE TO FOLLOW DANGER, WARNING, AND CAUTION MESSAGES COULD RESULT IN DEATH OR SERIOUS INJURY.

Machine safety

NOTICE: Notice indicates a situation that, if not avoided, could result in machine or property damage.

Throughout this manual you will find the signal word Notice followed by special instructions to prevent machine or property damage. The word Notice is used to address practices not related to personal safety.

Information

NOTE: Note indicates additional information that clarifies steps, procedures, or other information in this manual.

Throughout this manual you will find the word Note followed by additional information about a step, procedure, or other information in the manual. The word Note is not intended to address personal safety or property damage.

Safety rules

ACCIDENT PREVENTION

Most accidents or injuries that occur in workshops are the result of non-observance of simple and fundamental safety regulations.

For this reason, IN MOST CASES THESE ACCIDENTS CAN BE AVOIDED: by foreseeing possible causes and consequently acting with the necessary caution and care.

Accidents may occur with all types of machine, regardless of how well the machine in question was designed and built.

A careful and prudent mechanic is the best insurance against any accident.

Precise observance of the most basic safety rule is normally sufficient to avoid many serious accidents.

DANGER: Never carry out any cleaning, lubrication or maintenance operations when the engine is running.

GENERALITIES

- Carefully follow specified repair and maintenance procedures.
- Do not wear rings, wristwatches, jewellery, unbuttoned or loose articles of clothing such as: ties, torn clothing, scarves, open jackets or shirts with open zips that may remain entangled in moving parts.
It is advised to wear approved safety clothing, e.g: non-slip footwear, gloves, safety goggles, helmets, etc.
- Do not carry out repair operations with someone sitting in the driver's seat, unless the person is a trained technician who is assisting with the operation in question.
- Operate the vehicle and use the implements exclusively from the driver's seat.
- Do not carry out operations on the vehicle with the engine running, unless specifically indicated.
- Stop the engine and ensure that all pressure is relieved from hydraulic circuits before removing caps, covers, valves, etc.
- All repair and maintenance operations must be carried out with the greatest care and attention.
- Service stairs and platforms used in a workshop or in the field should be built in compliance with the safety rules in force.
- Disconnect the batteries and label all controls to indicate that the vehicle is being serviced. Block the machine and all equipment which should be raised.
- Do not check or fill fuel tanks, accumulator batteries, nor use starting liquid when smoking or near naked flames, as these fluids are inflammable.
- Brakes are inoperative if manually released for repair or maintenance purposes.
In such cases, the machine should be kept constantly under control using blocks or similar devices.
- The fuel nozzle should always be in contact with the filling aperture. Maintain this position until filling operations are completed in order to avoid possible sparks caused by the accumulation of static electricity.
- Only use specified towing points for towing the tractor. Connect the parts carefully and make sure that all pins and/or locks are secured in position before applying traction.
Never remain near the towing bars, cables or chains that are operating under load
- To move a disabled machine, use a trailer or a low-boy, if available.
- When loading or unloading the vehicle from the trailer, or other means of transport, select a flat area capable of sustaining the trailer or truck wheels, firmly secure the tractor to the truck or trailer and lock the wheels in the position.
- For electrical heaters, battery-chargers and similar equipment use exclusive auxiliary power supplies with a efficient ground to avoid electrical shock hazard.
- Always use lifting equipment and similar of appropriate capacity to lift or move heavy components.
- Take extra care if bystanders are present.
- Never pour gasoline or diesel oil into open, wide and low containers.
- Never use gasoline, diesel oil or other inflammable liquids as cleaning agents. Use non-flammable non-toxic proprietary solvents.
- Wear safety goggles with side guards when cleaning parts with compressed air.

- Limit the air pressure to a maximum of **2.1 bar (30.5 psi)**, according to local regulations.
- Do not run the engine in confined spaces without suitable ventilation.
- Do not smoke, use naked flames, or cause sparks in the area when fuel filling or handling highly inflammable liquids.
- Never use naked flames for lighting when working on the machine or checking for leaks.
- All movements must be carried out carefully when working under, on or near the vehicle and wear protective equipment: helmets, goggles and special footwear.
- When carrying out checks with the engine running, request the assistance of an operator in the driver's seat. The operator must maintain visual contact with the service technician at all times.
- If operating outside the workshop, position the machine on a flat surface and lock in position. If working on a slope, lock the vehicle in position and move to a flat area as soon as possible in order to ensure a safety position.
- Damaged or bent chains or cables are unreliable. Do not use them for lifting or trailing.
Always use suitable protective gloves when handling chains or cables.
- Chains should always be safely secured. Ensure that the connection is strong enough to hold the expected load. No persons should stop near the fastening point, trailing chains or cables.
- Maintenance and repair operations must be carried out in a CLEAN and DRY area, eliminate any water or oil spillage immediately.
- Do not create piles of oil or grease--soaked rags as they represent a serious fire hazard; store them in a closed metal container.
Before starting the vehicle or implements, make sure that the driver's seat is locked in position and always check that the area is free of persons or obstacles.
- Empty pockets of all objects that may unintentionally fall into the vehicle parts when disassembled.
- In the presence of protruding metal parts, use protective goggles or goggles with side guards, helmets, special footwear and gloves.
- Handle all parts carefully, do not put your hands or fingers between moving parts, wear suitable safety clothing -- safety goggles, gloves and shoes.

WELDING OPERATIONS

- When welding, use protective safety devices: tinted safety goggles, helmets, special overalls, gloves and footwear. All persons present in the area where welding is taking place must wear tinted goggles.
DO NOT LOOK AT ARC WITHOUT PROPER EYE PROTECTION.
- Where possible, remove the part or tool that requires arc welding from the tractor.
- Disconnect both cables from the battery. Isolate the cable ends to avoid contact with each other and the tractor.
- Position the welder ground clamp as near as possible to the area where welding is taking place.
- Remove the electronic control units located on the tractor if welding is to be carried out near these control units.
- Never allow welding cables to lay on, near or across any electrical wiring or electronic component while welding is in progress.
- Metal cables tend to fray with repeated use. Always use suitable protective devices (gloves, goggles, etc.) when handling cables.

START UP

- Never start the engine in confined spaces that are not equipped with adequate ventilation for exhaust gas extraction.
- Never bring your head, body, arms, legs, feet, hands, fingers near fans or rotating belts.

MOTOR

- Always loosen the radiator cap slowly before removing it to allow any remaining pressure in the system to be discharged. Coolant should be topped up only when the engine is stopped or idle if hot.
- Never fill up with fuel when the engine is running, especially if hot, in order to prevent the outbreak of fire as a result of fuel spillage
- Never check or adjust fan belt tension when the engine is running.

Never adjust the fuel injection pump when the vehicle is moving.

- Never lubricate the vehicle when the engine is running.

ELECTRICAL SYSTEMS

- If it is necessary to use auxiliary batteries, the cables must be connected at both sides as follows: (+) with (+) and (-) with (-).
- Avoid short-circuiting the terminals. GAS RELEASED FROM BATTERIES IS HIGHLY INFLAMMABLE.
- During charging, leave the battery compartment uncovered to improve ventilation.
- Do not check charge by placing metal articles across battery terminals.
- Avoid sparks or flames near the battery zone to prevent explosion hazards.
- Before servicing operations, check for fuel or current leaks. Eliminate any eventual leaks before starting work.
- Never charge batteries in confined spaces. Make sure that there is adequate ventilation in order to prevent accidental explosion hazards as a result of the accumulation of gases released during charging operations.
- Always disconnect the battery before performing any kind of servicing on the electrical system.

HYDRAULIC SYSTEMS

- Some fluid slowly coming out from a very small port can be almost invisible and be strong enough to penetrate the skin. Check for leaks using a piece of cardboard, NEVER USE HANDS.
- If any liquid penetrates skin tissue, call for medical aid immediately
- Serious skin infections may result if medical attention is not given.
- Use the specific tools when checking pressure values on the hydraulic system.

WHEELS AND TYRES

- Make certain that tires are correctly inflated to the pressure indicated by the Manufacturer. Periodically check possible damages to the rims and tires.
- Stand away from (at the side of) the tyre when checking inflation pressure.
- Only check pressure when the vehicle is unloaded and the tyres are cold, to avoid incorrect readings as a result of over-pressure.
- Do not re-use parts of recovered wheels as incorrect welding or brazing may heat the material, causing it to weaken and eventually damage or break the wheel.
- Never cut, nor weld a rim with the inflated tire assembled.
- When removing the wheels, lock both the front and rear vehicle wheels.
- Always position support stands when raising the vehicle, in order to conform to current safety regulations.
- Deflate the tyre before removing any object caught into the tyre tread.
- Never inflate tyres using inflammable gases; this could cause an explosion and put operator safety at risk.

REMOVAL AND RE-FITTING

- Lift and handle all heavy parts using suitable lifting equipment and make sure that all slings and hooks are correctly secured.
- Handle all parts carefully during lifting operations, be careful to personnel working near the load to be lifted. Never insert hands or fingers between parts, always wear approved accident prevention clothing (goggles, gloves and work boots).
- Avoid twisting chains or metal cables and always wear safety gloves when handling cables or chains.



SERVICE MANUAL

Engine

Farmall® 110U With 16x16 Semi-Powershift transmission
Farmall® 120U With 16x16 Semi-Powershift transmission

Engine - Torque

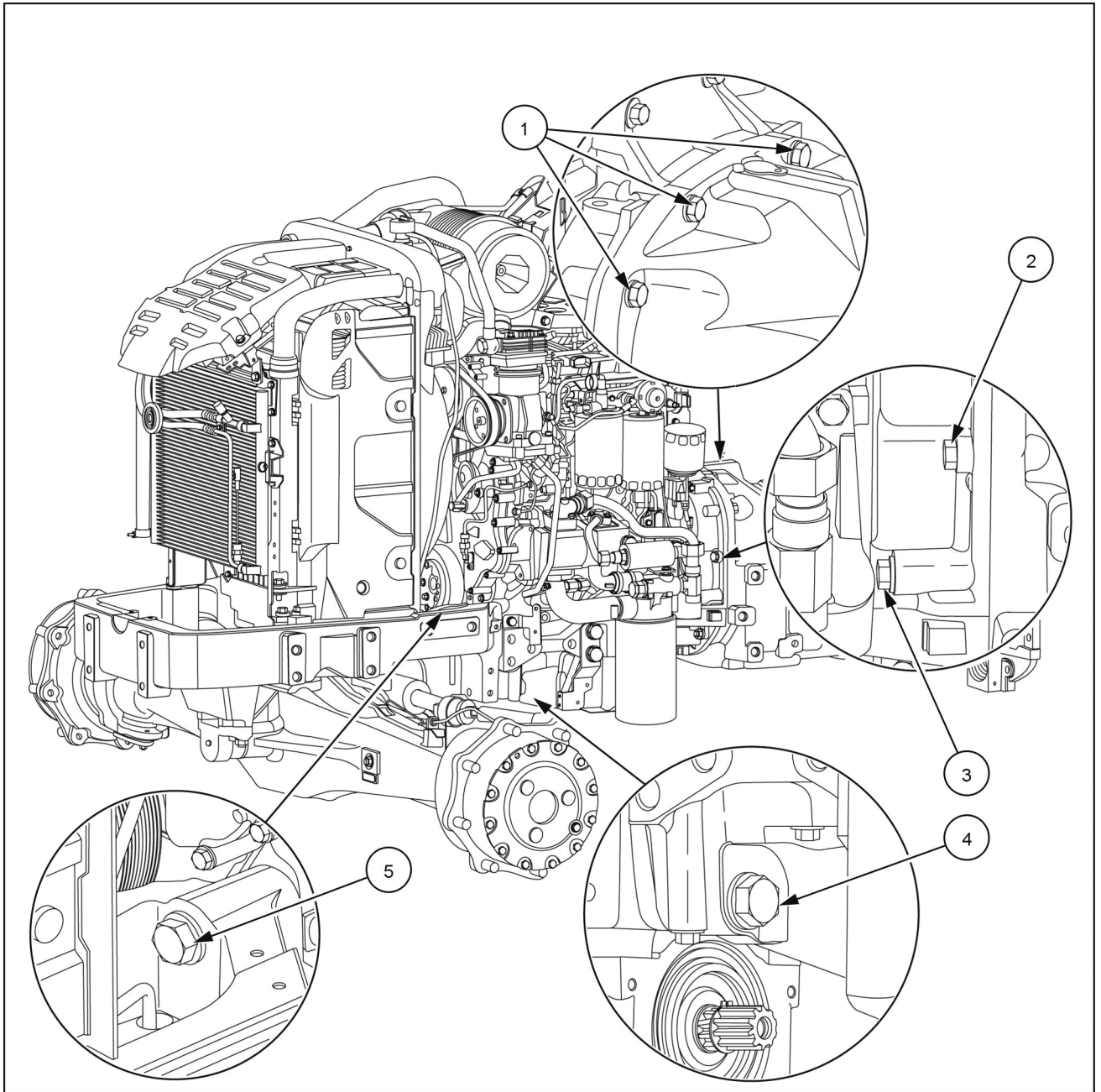

MOIL17TR00673GA 1

Part to tighten	Thread	Tighten torque
Bolt (5) securing the front axle to the engine block	M20 x 1.5 x 130	587 N·m (432.95 lb ft)
Bolt (4) securing the engine block to the front axle	M20 x 1.5 x 110	587 N·m (432.95 lb ft)
Bolt (1) securing the gearbox to the engine block	M12 x 1.25 x 50	121 N·m (89.25 lb ft)
Bolt (2) securing the engine block to the gearbox	M12 x 1.25 x 50	121 N·m (89.25 lb ft)
Bolt (3) securing the engine block to the gearbox	M12 x 1.25 x 90	121 N·m (89.25 lb ft)

Engine - Remove

⚠ WARNING

Heavy objects!

Lift and handle all heavy components using lifting equipment with adequate capacity. Always support units or parts with suitable slings or hooks. Make sure the work area is clear of all bystanders. Failure to comply could result in death or serious injury.

W0398A

⚠ WARNING

Avoid injury!

Handle all parts carefully. Do not place your hands or fingers between parts. Use Personal Protective Equipment (PPE) as indicated in this manual, including protective goggles, gloves, and safety footwear.

Failure to comply could result in death or serious injury.

W0208A

Prior operation:

Hood - Remove (90.100).

Side panels - Remove (90.100).

Battery - Remove (55.302)

Fuel tank - Remove (10.216).

Air conditioning - Evacuate (50.200)

Selective Catalytic Reduction (SCR) muffler and catalyst - Remove (10.500) .

Fender - Remove (90.116)

1. Remove the front ballast (if present) as described in **Front ballast - Remove (39.140)**
2. Position wooden wedges (1) between the front axle and the front axle support (2) to prevent articulation.

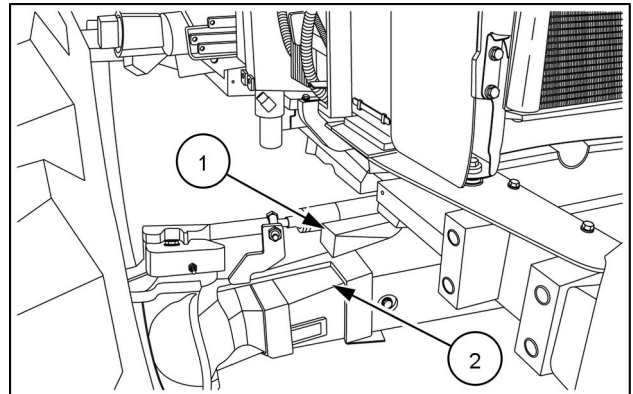

MOIL15TR01239AA 1

3. Release the steering cylinder control lines of the fastening clamps (1) to allow the front transmission drive shaft and its protection to be extracted.

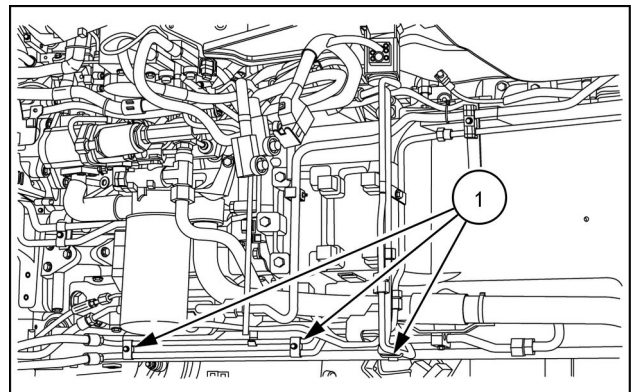

MOIL17TR01408AA 2

4. Remove the front transmission drive shaft (1) as described in **Front drive shaft - Remove (23.314)**.

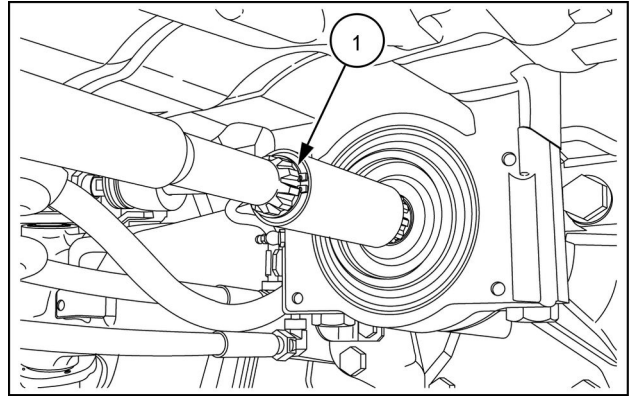

MOIL15TR01371AA 3

5. Position a container for transmission oil recovery under the transmission casing near the plug (1).
6. Remove the plug (1) and drain the transmission oil.

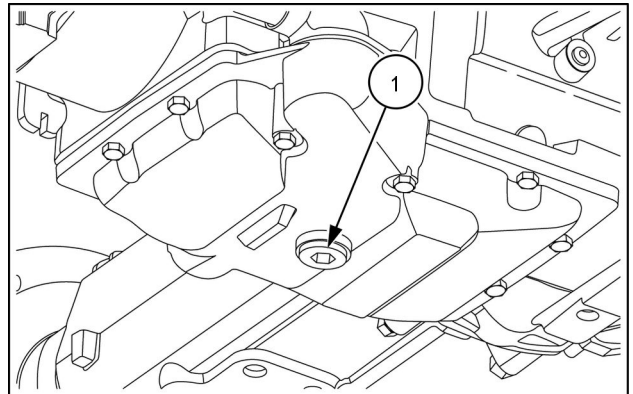

MOIL15TR01232AA 4

7. Disconnect the inlet pipe (1) of the filter loosening the 2 front retaining clamps.
8. Disconnect the hydraulic fitting (2) of the heat exchanger pipe.

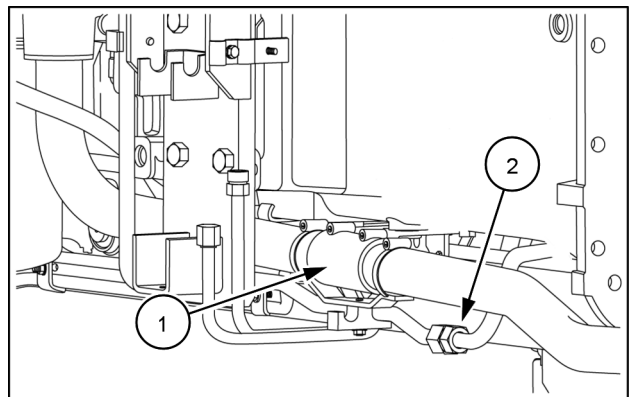

MOIL17I00390AA 5

9. Remove the steering cylinder control lines disconnecting the hydraulic fittings (1).
10. Disconnect the hydraulic fitting (2) of the oil pipe.
11. Uncouple the differential lock fitting (3).

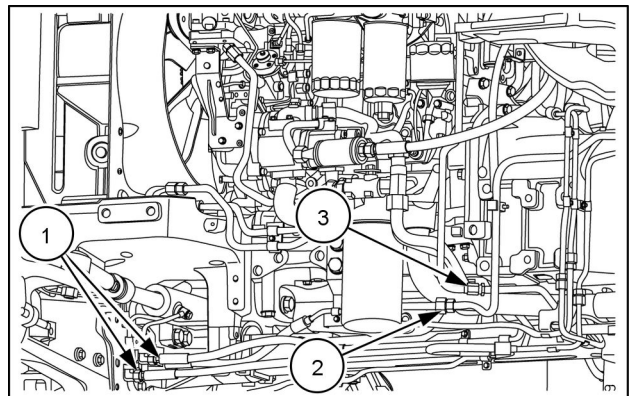

MOIL17TR01698AA 6

12. Uncouple the two electrical connectors **(1)** and the cab steering pump pipe **(2)**.

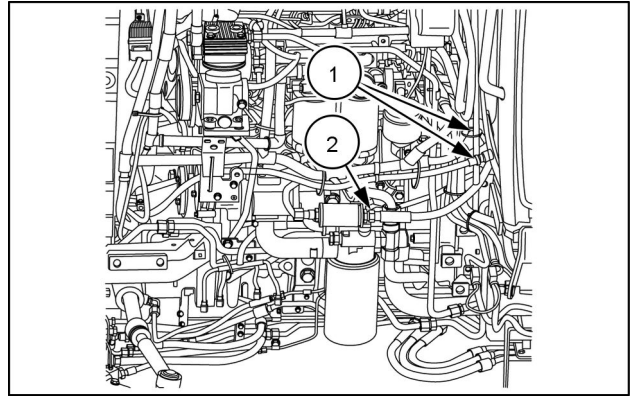

MOIL17TR01410AA 7

13. Disconnect the hydraulic connections **(1)** and **(2)** of the lines to the hydraulic steering control valve.
 14. Disconnect the two heating system pipes **(3)** and the protection screws **(4)** to disconnect the cables from the battery to the starter motor.

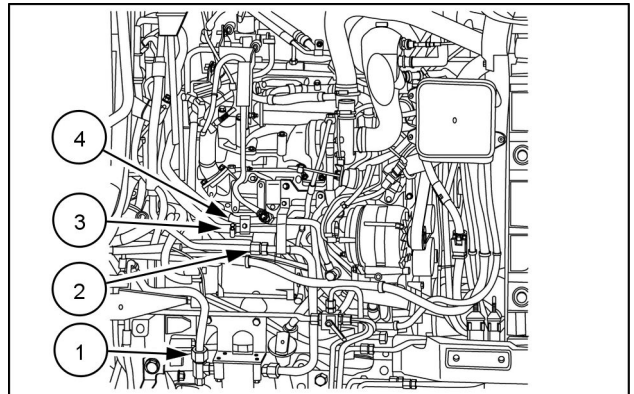

MOIL17TR01412AA 8

15. Uncouple the oil delivery fitting **(1)** to the control valves.

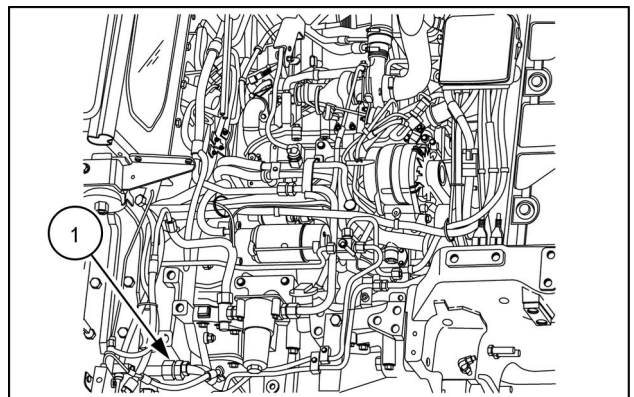

MOIL17TR01413AA 9

16. Disconnect the hydraulic fitting **(3)** on the capacitor **(4)** and loosen the screw **(1)** of the retaining clamp.
 17. Disconnect the sensor wiring **(2)**.

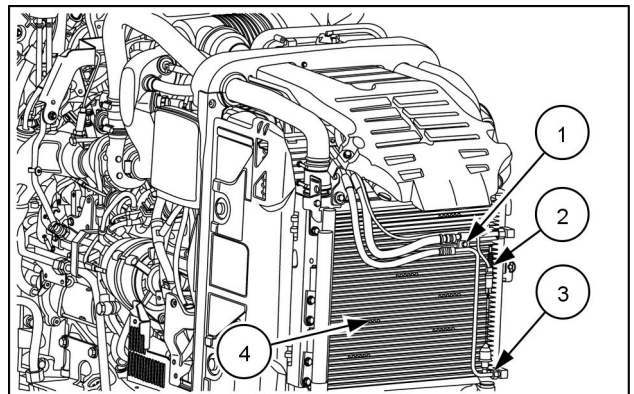

MOIL17TR01665AA 10

18. Loosen the retaining nuts (1) and remove the plate (2) securing the air-conditioning system lines (3).

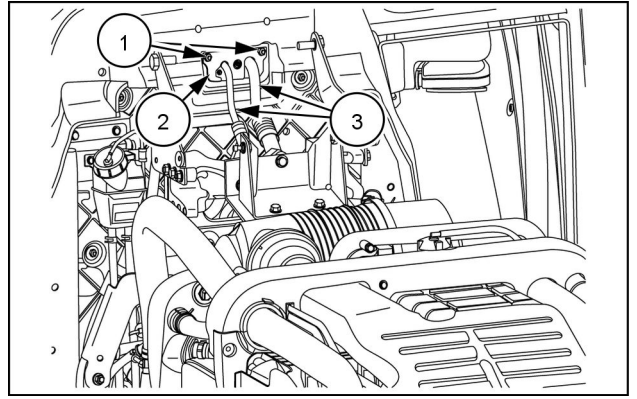

MOIL17TR00624AA 11

19. Disconnect the air conditioning system lines (1) from the cab loosening the screws (2).

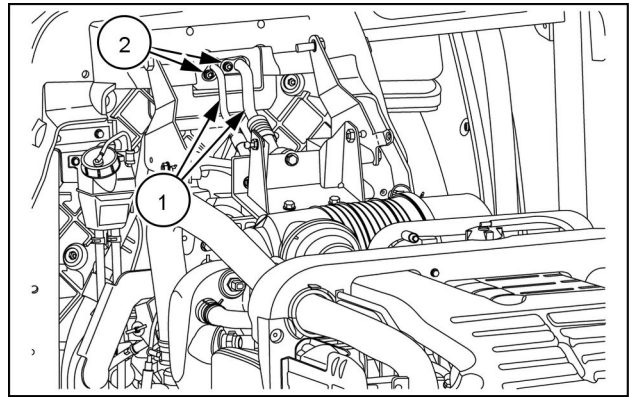

MOIL17TR00625AA 12

20. Loosen the retaining nuts and remove the plate (1) retaining the air-conditioning system lines (2).

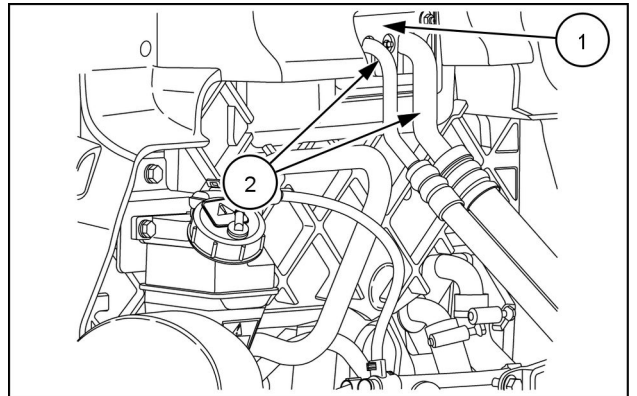

MOIL17TR00623AA 13

21. Uncouple the connector (1) from the brake fluid tank.

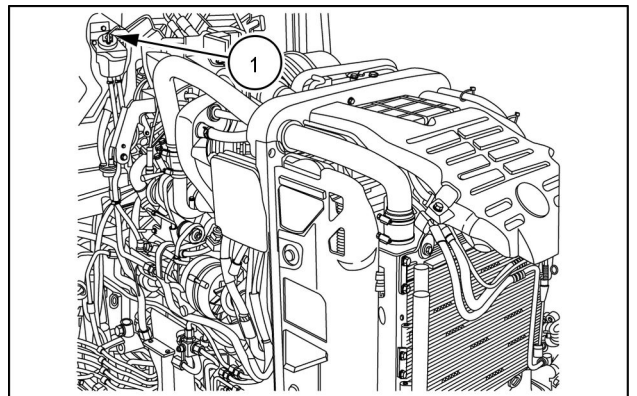

MOIL17TR01415AA 14

22. Remove the protection **(1)** above the RH ladder by loosening the four screws **(2)**.
23. Remove the cover **(3)** of the fuse compartment using the two retaining clips.
24. Release the fuse compartment below the RH ladder from the fuse compartment support, the battery connector and the battery positive and the sensors to SCR.

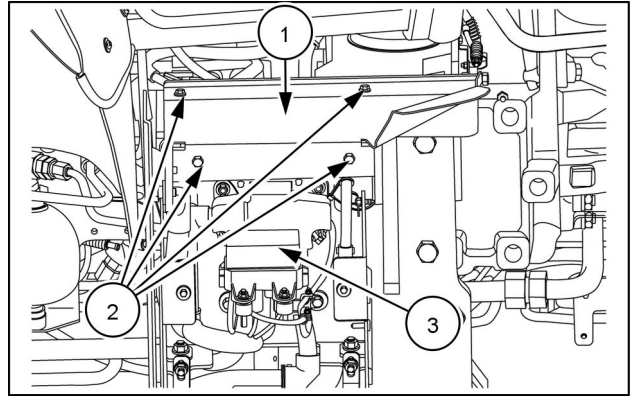

MOIL17TR01666AA 15

25. Acting from the bottom of the machine, loosen the screws **(1)** securing the cable **(2)** and bring the fuse compartment to the front suspension.

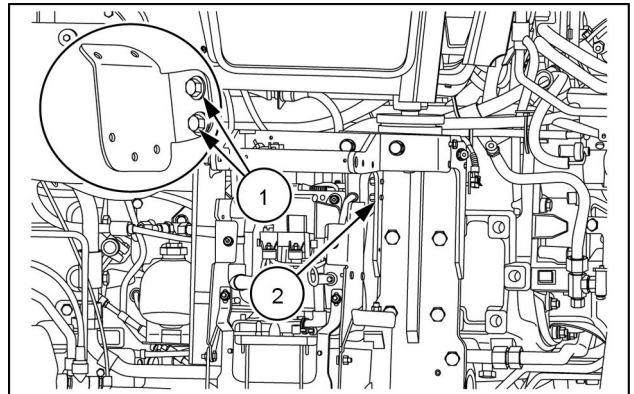

MOIL17TR01667AA 16

26. Bring the cable **(1)** behind the line of the flame guard line to allow the front suspension to advance.
27. Loosen the screw **(2)**
28. Remove the fuse block cover.
29. Release the cables from the fuse compartment, removing the screws **(3)** securing the cable **(1)**.

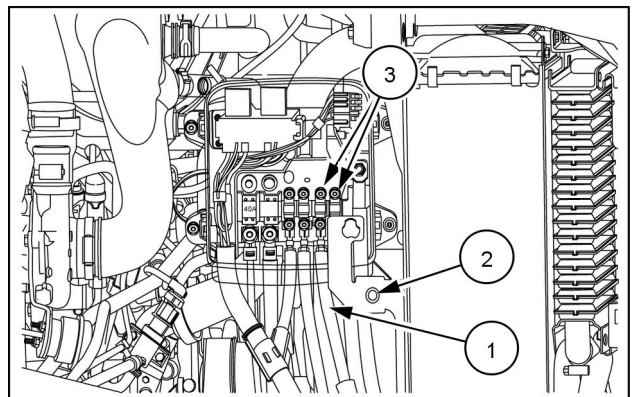

MOIL17TR01668AA 17

30. Loosen the retaining clamps to remove the aftercooler line **(1)** on the left-hand side of the engine.

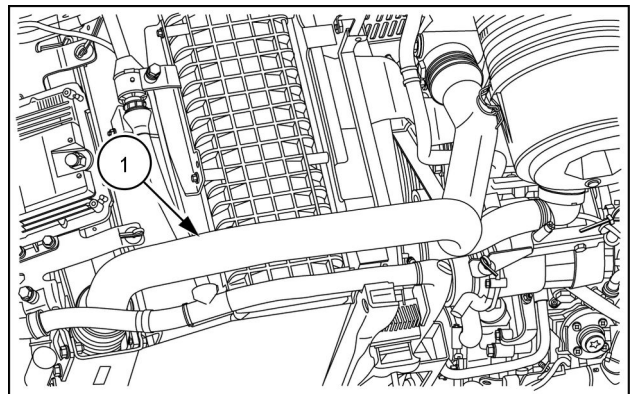

MOIL15TR00555AA 18

31. Remove the expansion tank support as described in the procedure **Expansion tank - Remove (10.400)**
32. Remove the air filter as described in the procedure **Air cleaner - Remove (10.202)**.
33. Remove the retaining clamp **(1)** to release the lines.

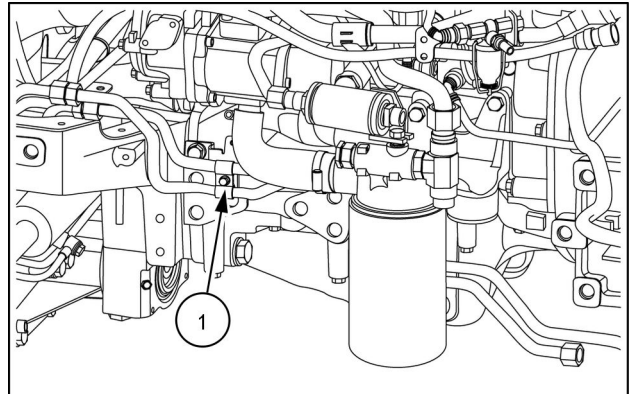

MOIL15TR01227AA 19

34. Disconnect the couplings **(1)** and **(2)**.

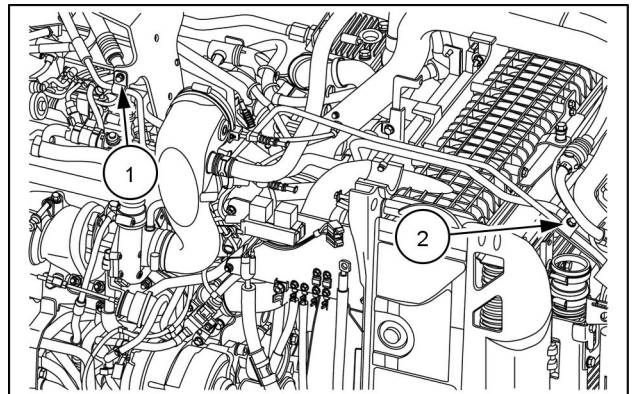

MOIL17TR01669AA 20

35. Remove the air conditioning line **(1)** from the compressor.

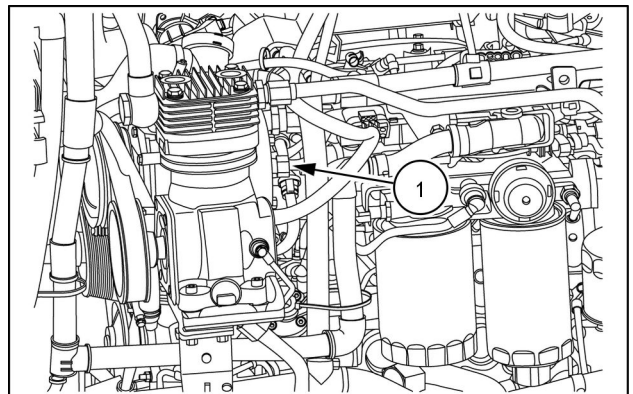

MOIL17TR01670AA 21

36. On the RH side, remove the protective grille (1).

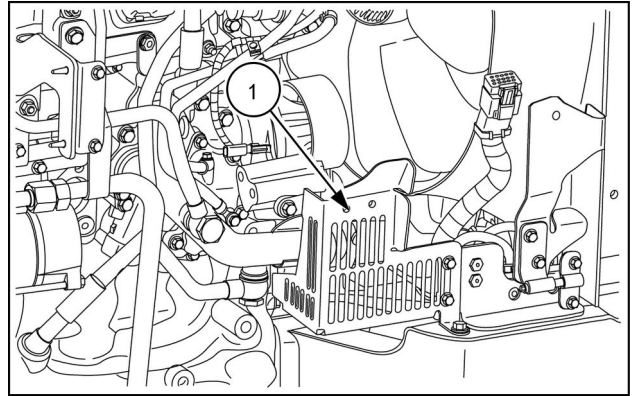

MOIL15TR00544AA 22

37. Loosen the retaining clamp (1) and disconnect the line (2) from the conveyor.

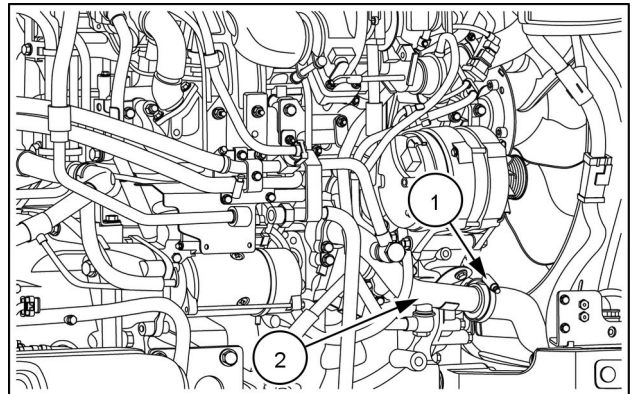

MOIL15TR01222AA 23

38. Loosen the retaining clamp (2) and disconnect the pipe (1) from the conveyor (3).

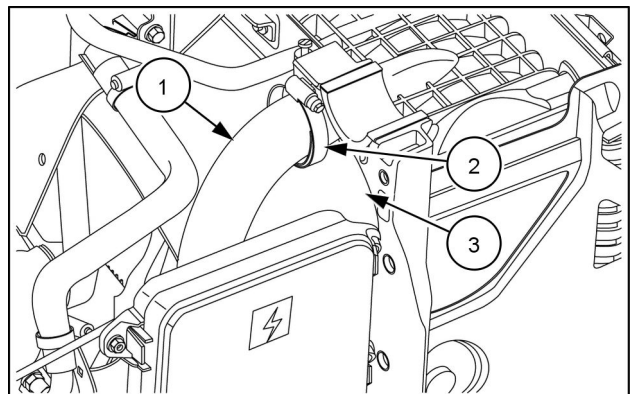

MOIL15TR01223AA 24

39. On the LH side, remove the protective grille (1).

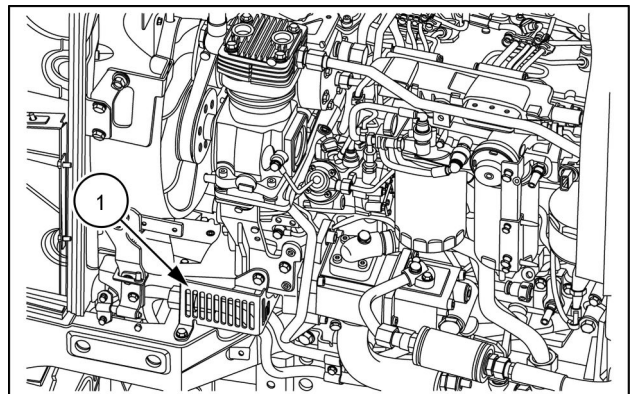

MOIL17TR01696AA 25

40. Disconnect the return line (1) from the radiator and the delivery line (2) to the radiator.

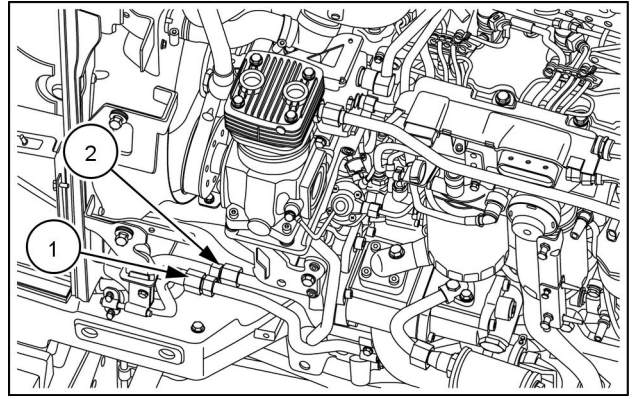

MOIL17TR01697AA 26

41. Position the movable tool for dismantling tractors **380003114** (2) with the support bracket and adapter plate under the engine. Place a wooden block (1) in the contact points between the tool and the engine.

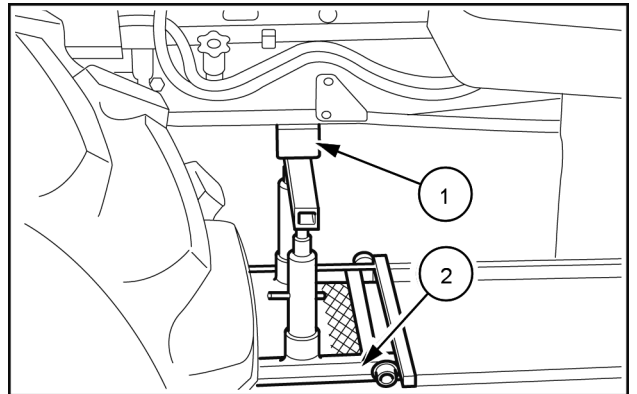

WLAPL4S10C140A 27

42. Remove the retaining screws (1) between the engine casing (2) and the transmission casing (3).

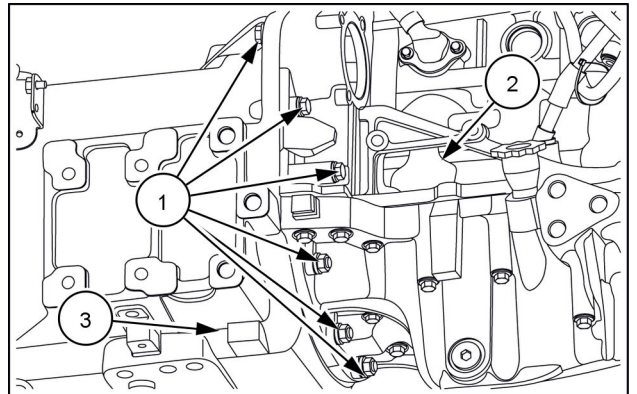

MOIL15TR01229AA 28

43. Separate the engine (1) from the transmission using the specific tool **380003114** (2).

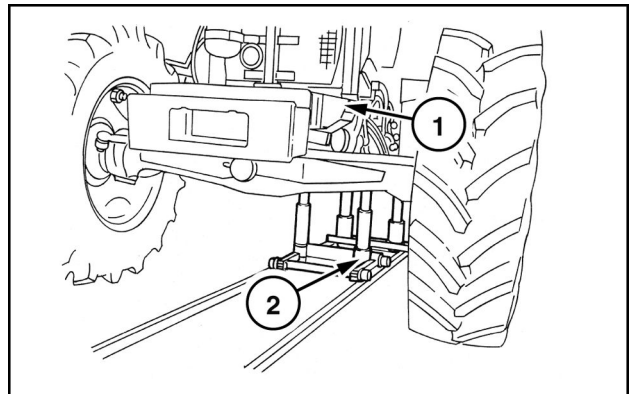

WLAPL4S10C131AA 29

44. Insert the fixed jack stand (1) under the ballast support and secure the front wheels with wooden wedges (2).

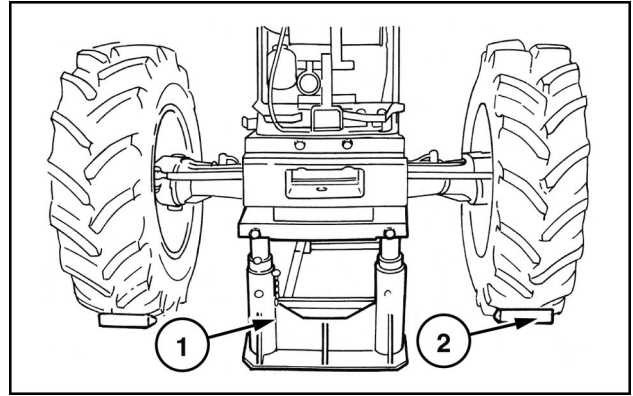

WLAPL4S10C132AA 30

45. Position a fixed jack stand (3) under the splined support (1) of the front axle Power Take-Off (PTO), placing a wooden plug (2) between parts (3) and (1).

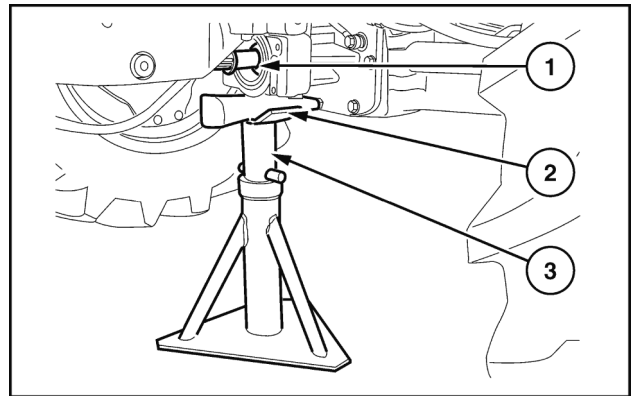

WLAPL4S10C133A 31

46. Disconnect the wiring harness starting from the engine control unit (1) up to the maxi fuse box taking care to disconnect the temperature and pressure sensors placed on the engine.

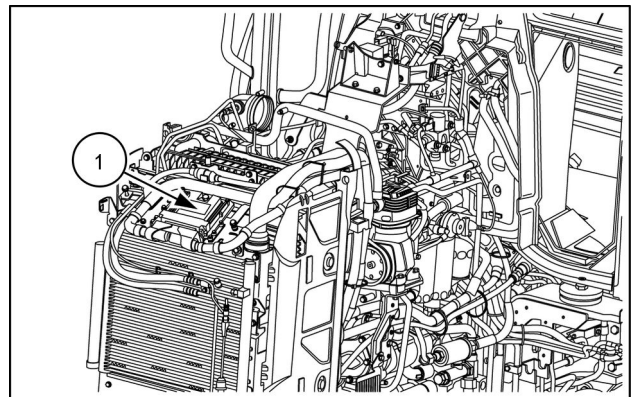

MOIL17TR01672AA 32

47. Loosen the screws (1) and remove the maxi fuse compartment.

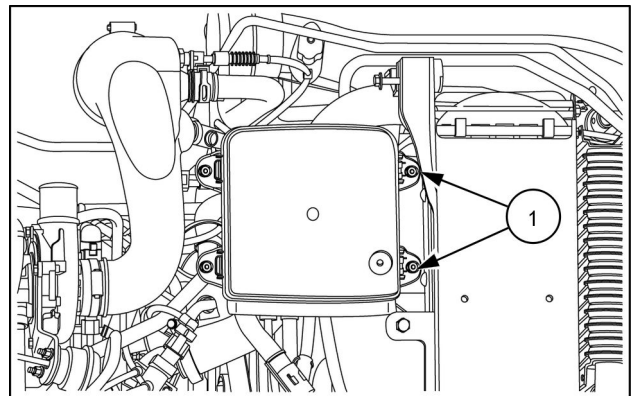

MOIL17TR01673AA 33

48. Add a rope or chain **(1)** also on the front of the engine. Take up the slack with the lifting device, keeping the engine balanced.

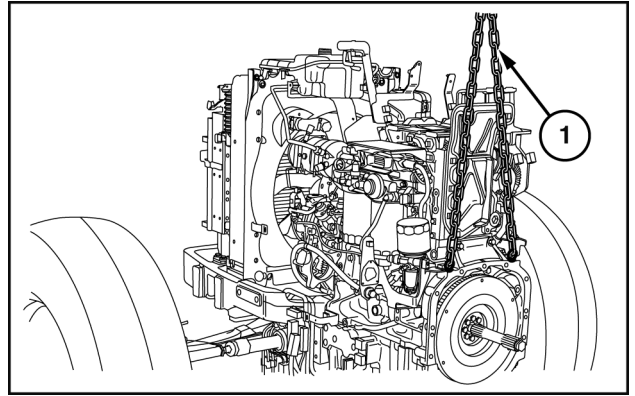

WLAPL4S10C136A 34

49. Loosen the 4 fastening screws **(1)** (2 per side) of the front suspension from the engine block.

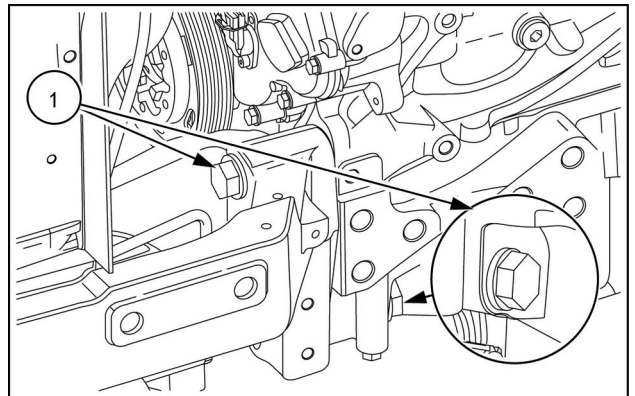

MOIL15TR01702AA 35

50. Check that there are no parts still connected or that interfere with the aftercooler group and the engine.
51. Slowly remove the engine **(2)** from the front suspension **(3)** avoiding incorrect movements to prevent damaging the fan **(1)** and the radiator body.

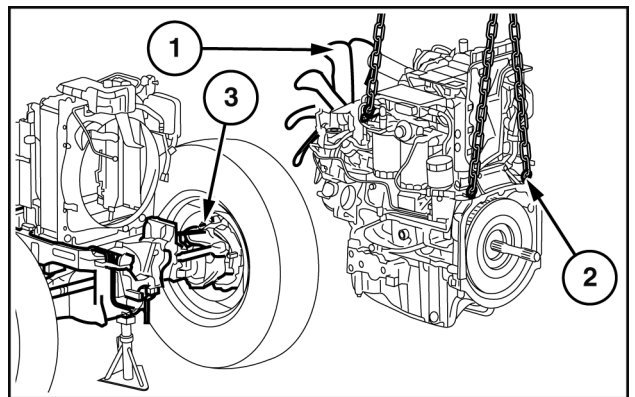

WLAPL4S10C138A 36

Engine - Install

⚠ WARNING

Heavy objects!

Lift and handle all heavy components using lifting equipment with adequate capacity. Always support units or parts with suitable slings or hooks. Make sure the work area is clear of all bystanders. Failure to comply could result in death or serious injury.

W0398A

⚠ WARNING

Avoid injury!

Handle all parts carefully. Do not place your hands or fingers between parts. Use Personal Protective Equipment (PPE) as indicated in this manual, including protective goggles, gloves, and safety footwear.

Failure to comply could result in death or serious injury.

W0208A

Prior operation:

Engine - Remove (10.001).

1. Slowly position the engine (2) on the front suspension (3) avoiding incorrect movements to prevent damaging the fan (1) and the radiator body.

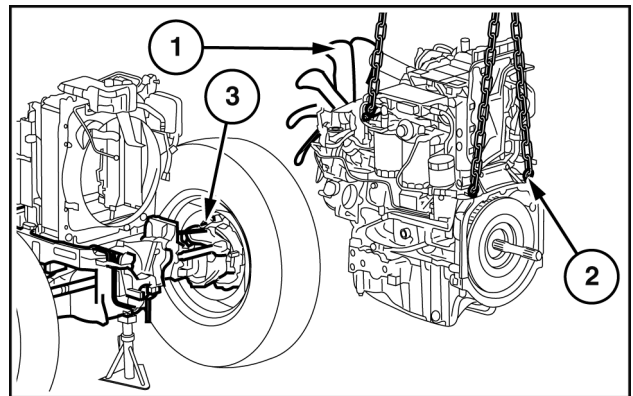

WLAPL4S10C138A 1

2. Secure the front suspension (4) to the engine block (2) tightening the screws (1) and (3) as described in **Engine - Torque (10.001)**.

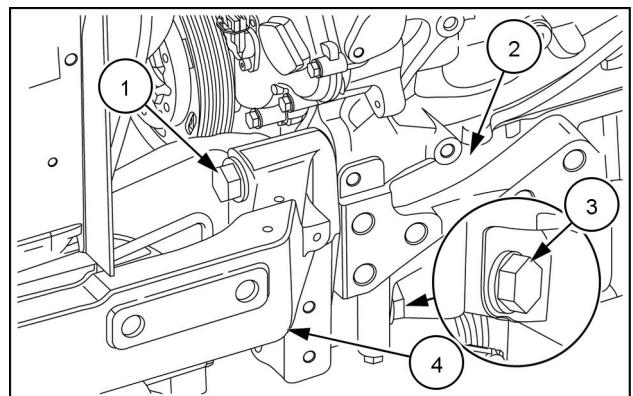

MOIL15TR01702AA 2

3. Using the special tool **380003114 (2)** move the whole engine lock front suspension **(1)** towards the transmission casing.

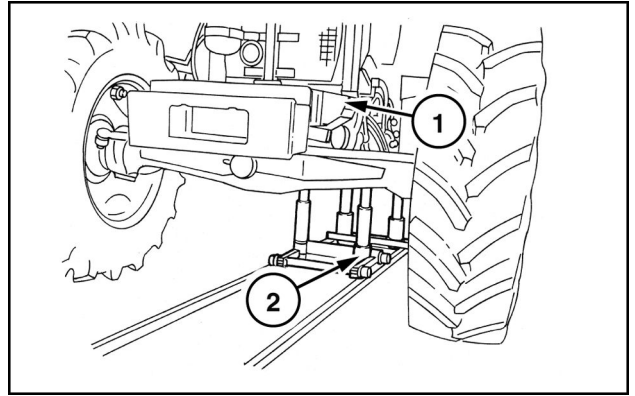

WLAPL4S10C131AA 3

4. Secure the engine **(2)** to the transmission casing **(3)** tightening the screws **(1)** as described in **Engine - Torque (10.001)**.

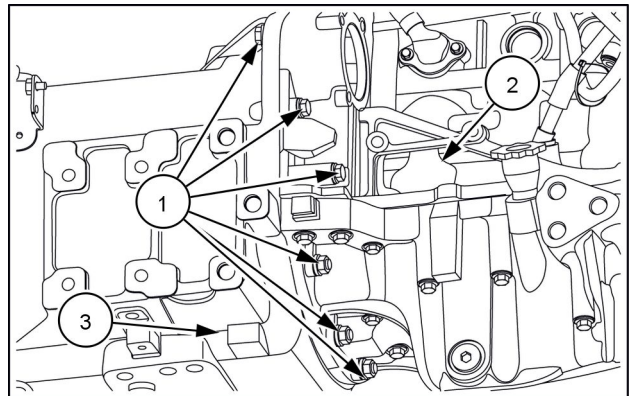

MOIL15TR01229AA 4

5. Remove the special tool **(2) 380003114** recovering the adapter plate **(1)**.

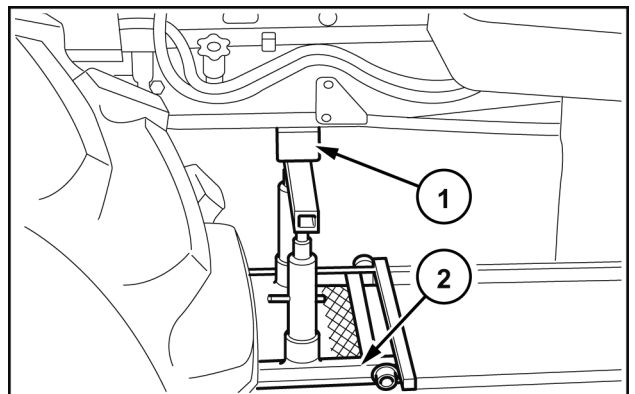

WLAPL4S10C140A 5

6. Refit the maxi fuse compartment and tighten the screws **(1)**.

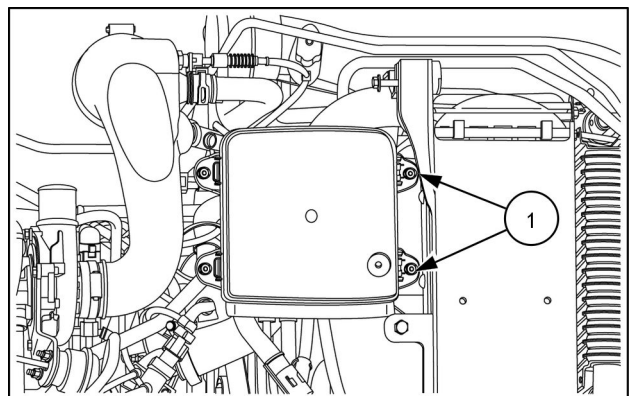

MOIL17TR01673AA 6

7. Starting from the engine control unit (1), lay out the electric wiring harness restoring the connections of the temperature and pressure sensors placed on the engine.

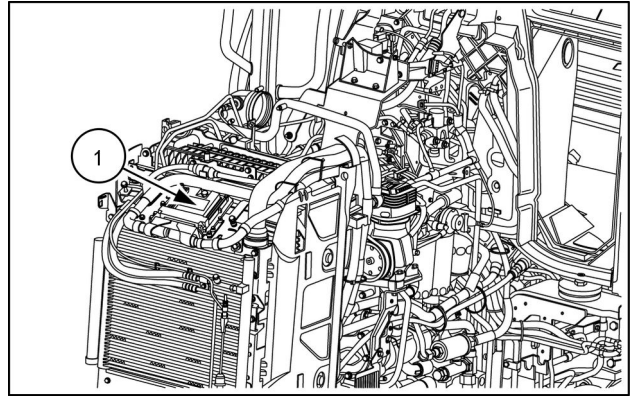

MOIL17TR01672AA 7

8. On the LH side, reconnect the return line (1) from the radiator and the delivery line (2) to the radiator.

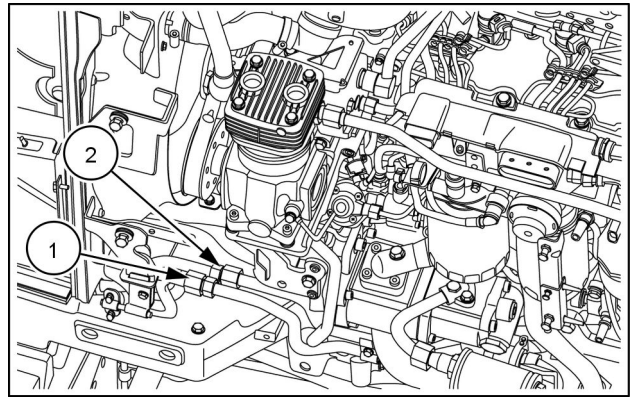

MOIL17TR01697AA 8

9. Install the protective grill (1).

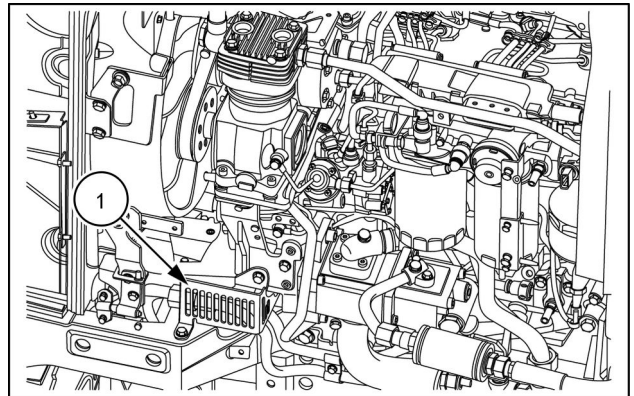

MOIL17TR01696AA 9

10. Tighten the retaining clamp (2) and connect the pipe (1) from the conveyor (3).

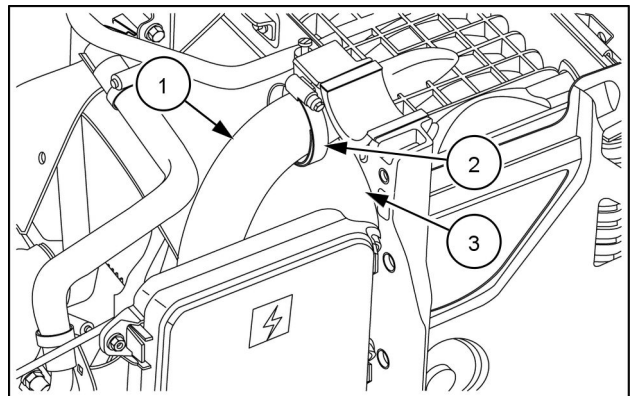

MOIL15TR01223AA 10

11. On the RH side, tighten the retaining clamp **(1)** and connect the pipe **(2)** from the conveyor .

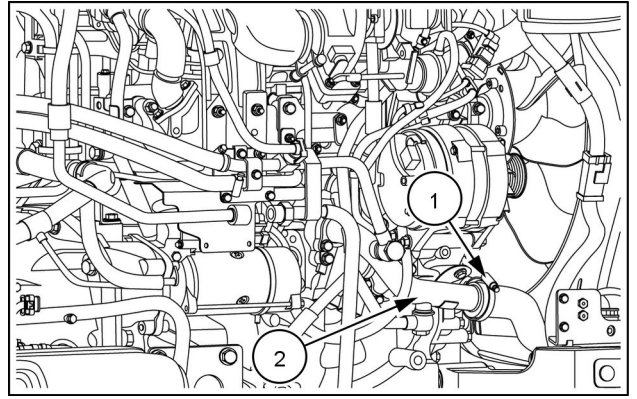

MOIL15TR01222AA 11

12. Install the protective grill **(1)**.

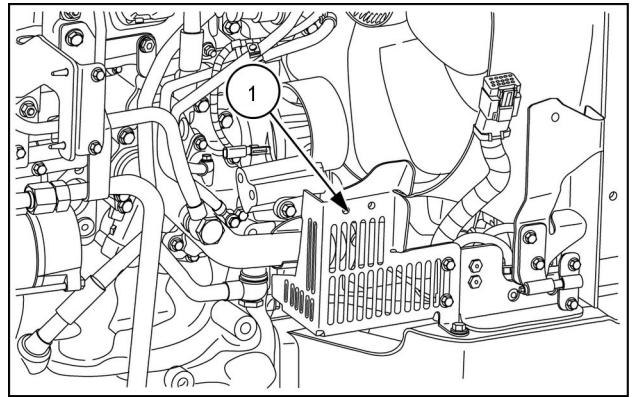

MOIL15TR00544AA 12

13. Fit the air conditioning line **(1)** from the compressor.

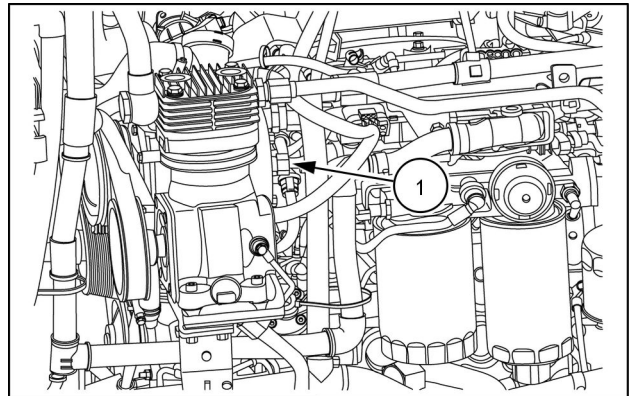

MOIL17TR01670AA 13

14. Connect the couplings **(1)** and **(2)**.

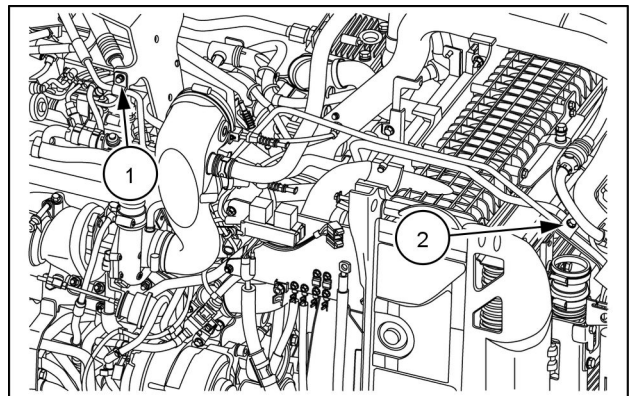

MOIL17TR01669AA 14

15. Fasten the retaining clamp (1).

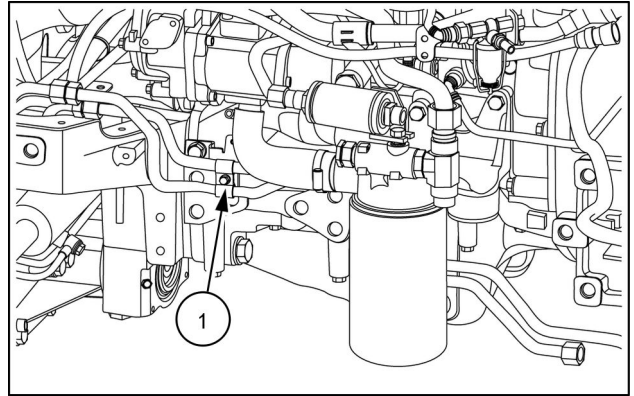

MOIL15TR01227AA 15

16. Fit the air filter as described in the procedure **Air cleaner - Install (10.202)**.
17. Fit the expansion tank support as described in the procedure **Expansion tank - Install (10.400)**
18. Install the aftercooler lines (1) on the left-hand side of the engine and tighten the retaining clamps.

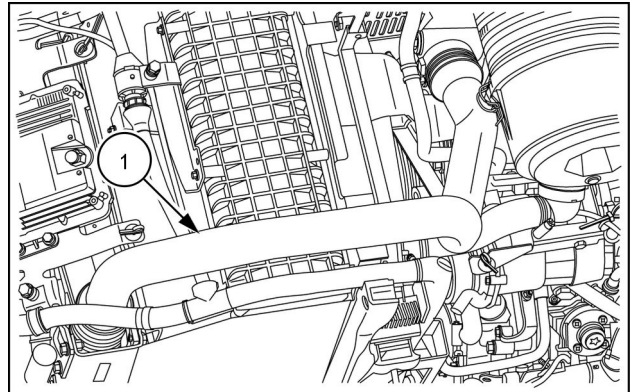

MOIL15TR00555AA 16

19. Restore the cables in the fuse compartment and tighten the screws (3) securing the cable (1).
20. Fit the fuse block cover.
21. Tighten the screw (2)
22. Correctly position the cable (1).

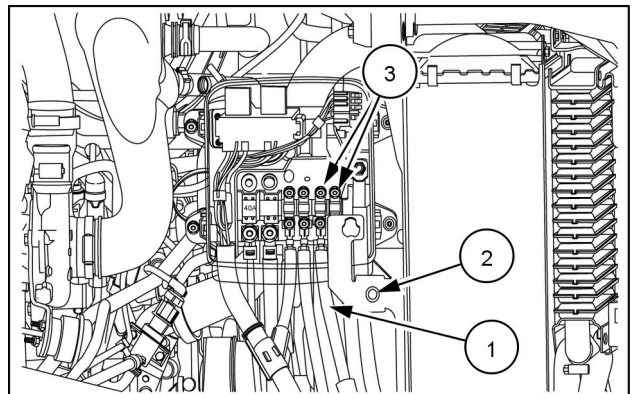

MOIL17TR01668AA 17

23. Acting from the bottom of the machine, tighten the screws **(1)** securing the cable **(2)** and bring the fuse compartment to its seat.

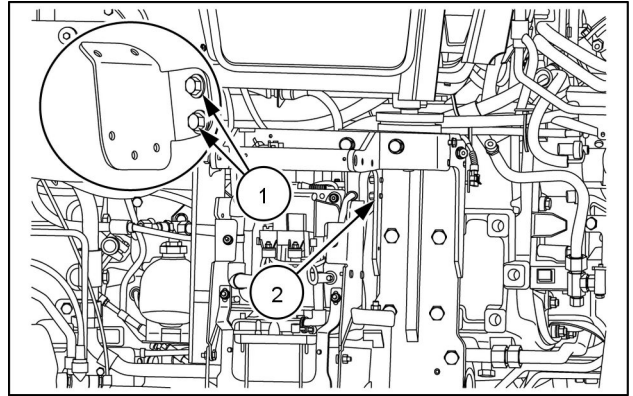

MOIL17TR01667AA 18

24. Connect the fuse compartment, the battery connector and the battery positive and the sensors to the SCR to the fuse compartment below the RH ladder.
25. Fit the cover **(3)** of the fuse compartment using the two retaining clips.
26. Fit the protection **(1)** above the RH ladder and tighten the four screws **(2)**.

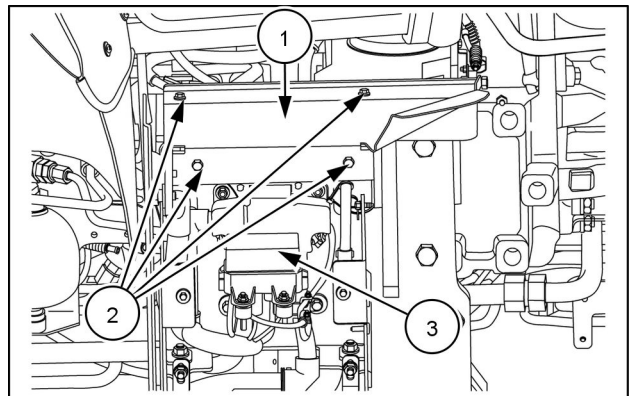

MOIL17TR01666AA 19

27. Connect the connector **(1)** to the brake fluid tank.

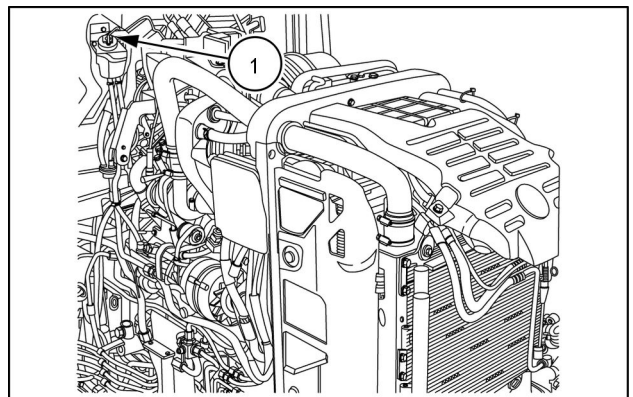

MOIL17TR01415AA 20

28. Reposition the plate **(1)** securing the air-conditioning lines **(2)** and tighten the nuts.

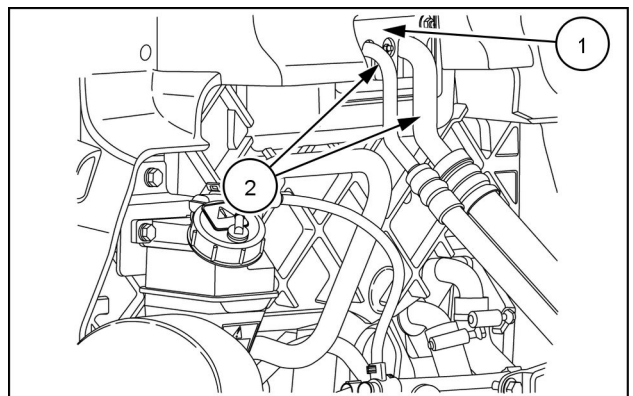

MOIL17TR00623AA 21

29. Connect the cab air conditioning system lines (1) and tighten the screws (2).

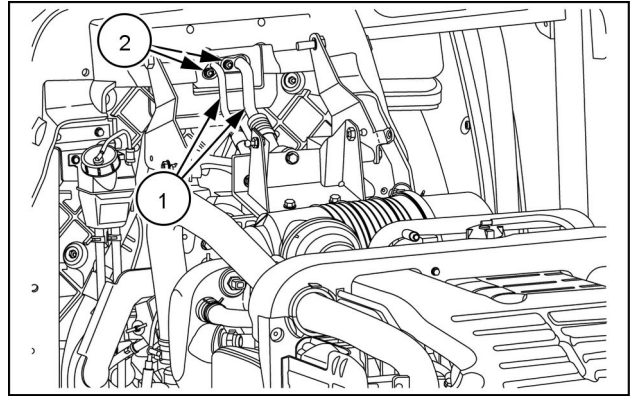

MOIL17TR00625AA 22

30. Reposition the plate (2) securing the air-conditioning system lines (3) and tighten the retaining nuts (1).

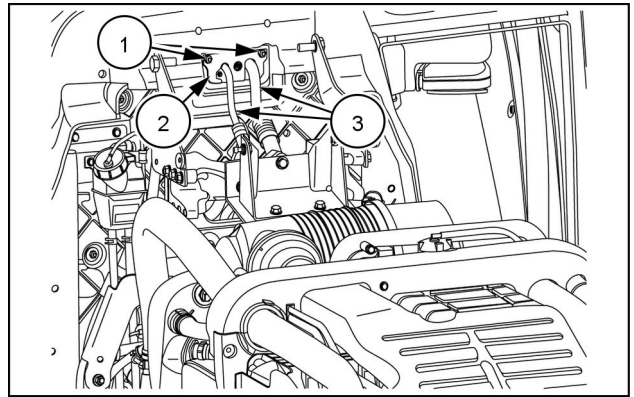

MOIL17TR00624AA 23

31. Connect the sensor wiring (2).
32. Connect the hydraulic fitting (3) on the condenser (4) and tighten the (1) retaining clamp screw.

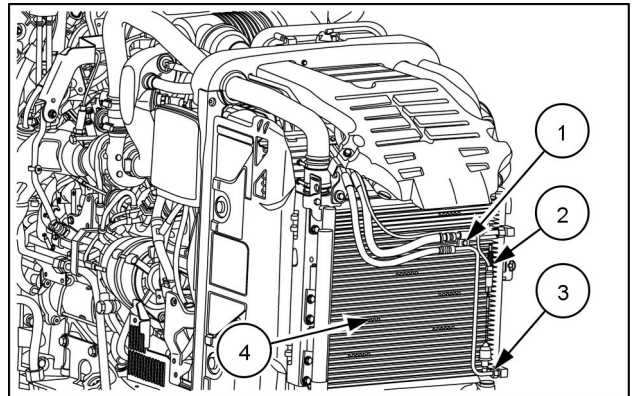

MOIL17TR01665AA 24

33. Connect the oil delivery fitting (1) to the control valves.

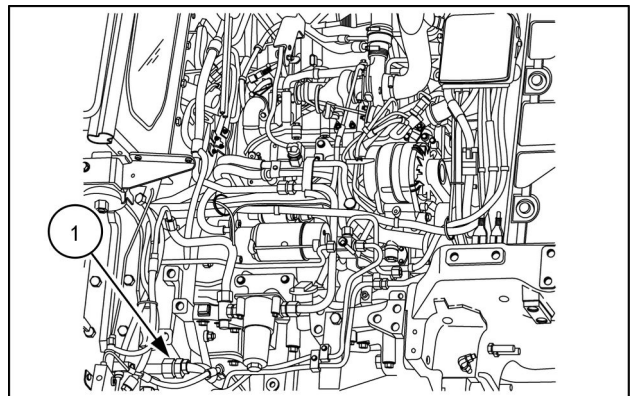

MOIL17TR01413AA 25



Suggest:

If the above button click is invalid.

Please download this document

first, and then click the above link

to download the complete manual.

Thank you so much for reading

34. Connect the cables from the battery to the starter motor and connect the two pipes of the heating system (3) and the two protection screws (4).
35. Connect the hydraulic connections (1) and (2) of the lines to the hydraulic steering system control valve.

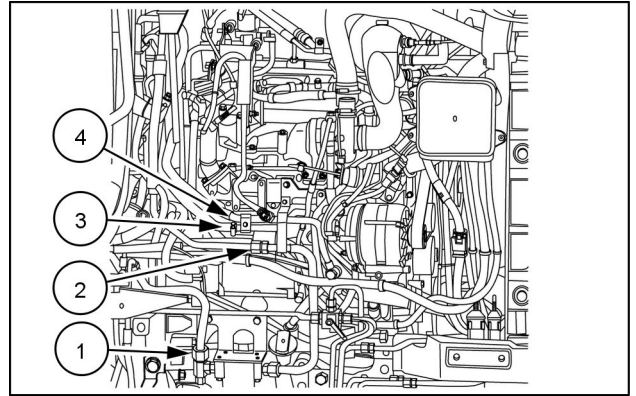

MOIL17TR01412AA 26

36. Connect the two electrical connectors (1) and the cab steering pump pipe (2).

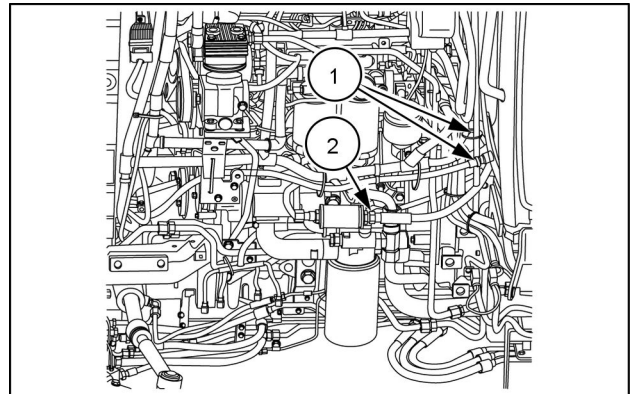

MOIL17TR01410AA 27

37. Connect the differential lock fitting (3).
38. Connect the hydraulic fitting (2) in the oil pipe.
39. Connect the steering cylinder control lines and disconnect the hydraulic fittings (1).

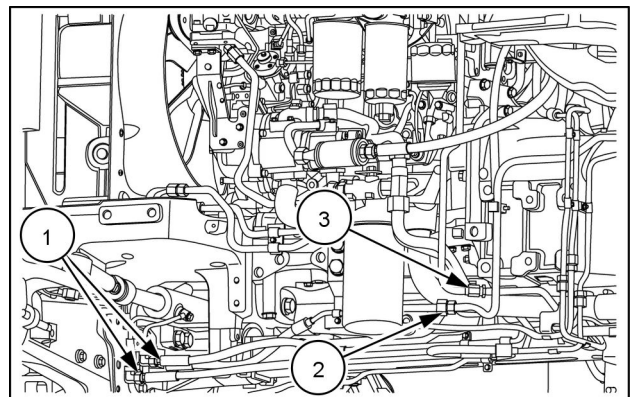

MOIL17TR01698AA 28

40. Connect the hydraulic fitting (2) of the heat exchanger line.
41. Connect the inlet pipe (1) of the filter tightening the two front retaining clamps.

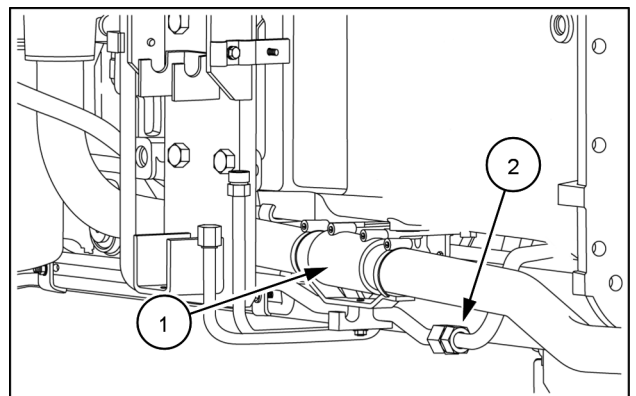

MOIL17H00390AA 29

<https://www.ebooklibonline.com>

Hello dear friend!

Thank you very much for reading.

Enter the link into your browser.

The full manual is available for immediate download.

<https://www.ebooklibonline.com>