

FARMALL® I 10A
FARMALL® I 20A
FARMALL® I 30A
FARMALL® I 40A
Tier 4B (final)
Tractor

PIN CT00001M and above

SERVICE MANUAL

Part number 47924636

1st edition English

December 2015

CASE II
AGRICULTURE



SERVICE MANUAL

Farmall® 110A 110 HP TIER 4B (final) engine, 2WD, and ROPS. , Farmall® 110A 110 HP TIER 4B (final) engine, 2WD, and cab. , Farmall® 110A 110 HP TIER 4B (final) engine, 4WD, and ROPS. , Farmall® 110A 110 HP TIER 4B (final) engine, 4WD, and cab. , Farmall® 120A 119 HP TIER 4B (final) engine, 2WD, and ROPS. , Farmall® 120A 119 HP TIER 4B (final) engine, 2WD, and cab. , Farmall® 120A 119 HP TIER 4B (final) engine, 4WD, and ROPS. , Farmall® 120A 119 HP TIER 4B (final) engine, 4WD, and cab. , Farmall® 130A 130 HP TIER 4B (final) engine, 2WD, and ROPS. , Farmall® 130A 130 HP TIER 4B (final) engine, 2WD, and cab. , Farmall® 130A 130 HP TIER 4B (final) engine, 4WD, and ROPS. , Farmall® 130A 130 HP TIER 4B (final) engine, 4WD, and cab. , Farmall® 140A 139 HP TIER 4B (final) engine, 2WD, and ROPS. , Farmall® 140A 139 HP TIER 4B (final) engine, 2WD, and cab. , Farmall® 140A 139 HP TIER 4B (final) engine, 4WD, and ROPS. , Farmall® 140A 139 HP TIER 4B (final) engine, 4WD, and cab.

Link Product / Engine

Product	Market Product	Engine
Farmall® 110A 110 HP TIER 4B (final) engine, 2WD, and ROPS.	North America	F4DFE413U*B001
Farmall® 110A 110 HP TIER 4B (final) engine, 4WD, and ROPS.	North America	F4DFE413U*B001
Farmall® 110A 110 HP TIER 4B (final) engine, 2WD, and cab.	North America	F4DFE413U*B001
Farmall® 110A 110 HP TIER 4B (final) engine, 4WD, and cab.	North America	F4DFE413U*B001
Farmall® 120A 119 HP TIER 4B (final) engine, 2WD, and ROPS.	North America	F4DFE413T*B001
Farmall® 120A 119 HP TIER 4B (final) engine, 4WD, and ROPS.	North America	F4DFE413T*B001
Farmall® 120A 119 HP TIER 4B (final) engine, 2WD, and cab.	North America	F4DFE413T*B001
Farmall® 120A 119 HP TIER 4B (final) engine, 4WD, and cab.	North America	F4DFE413T*B001
Farmall® 130A 130 HP TIER 4B (final) engine, 2WD, and ROPS.	North America	F4DFE413S*B001
Farmall® 130A 130 HP TIER 4B (final) engine, 4WD, and ROPS.	North America	F4DFE413S*B001
Farmall® 130A 130 HP TIER 4B (final) engine, 2WD, and cab.	North America	F4DFE413S*B001
Farmall® 130A 130 HP TIER 4B (final) engine, 4WD, and cab.	North America	F4DFE413S*B001
Farmall® 140A 139 HP TIER 4B (final) engine, 2WD, and ROPS.	North America	F4DFE413R*B001
Farmall® 140A 139 HP TIER 4B (final) engine, 4WD, and ROPS.	North America	F4DFE413R*B001
Farmall® 140A 139 HP TIER 4B (final) engine, 2WD, and cab.	North America	F4DFE413R*B001
Farmall® 140A 139 HP TIER 4B (final) engine, 4WD, and cab.	North America	F4DFE413R*B001

<https://www.ebooklibonline.com>

Hello dear friend!

Thank you very much for reading.

Enter the link into your browser.

The full manual is available for immediate download.

<https://www.ebooklibonline.com>

Contents

INTRODUCTION

Engine	10
[10.001] Engine and crankcase	10.1
[10.202] Air cleaners and lines	10.2
[10.206] Fuel filters	10.3
[10.216] Fuel tanks	10.4
[10.254] Intake and exhaust manifolds and muffler	10.5
[10.310] Aftercooler.....	10.6
[10.400] Engine cooling system	10.7
[10.414] Fan and drive	10.8
[10.500] Selective Catalytic Reduction (SCR) exhaust treatment.....	10.9
Clutch	18
[18.100] Clutch mechanical release control	18.1
[18.110] Clutch and components	18.2
[18.112] Slip clutch or flywheel damper	18.3
Transmission	21
[21.109] Transmission cooler and lines.....	21.1
[21.112] Power shuttle transmission.....	21.2
[21.114] Mechanical transmission	21.3
[21.134] Power shuttle transmission external controls	21.4
[21.154] Power shuttle transmission internal components	21.5
[21.160] Creeper	21.6
Four-Wheel Drive (4WD) system	23
[23.202] Electro-hydraulic control	23.1
[23.304] Four-Wheel Drive (4WD) gearbox	23.2
[23.314] Drive shaft.....	23.3

Front axle system	25
[25.100] Powered front axle	25.1
[25.102] Front bevel gear set and differential	25.2
[25.108] Final drive hub, steering knuckles, and shafts	25.3
[25.400] Non-powered front axle	25.4
Rear axle system.....	27
[27.100] Powered rear axle.....	27.1
[27.106] Rear bevel gear set and differential.....	27.2
[27.120] Planetary and final drives	27.3
Power Take-Off (PTO).....	31
[31.114] Two-speed rear Power Take-Off (PTO)	31.1
Brakes and controls	33
[33.110] Parking brake or parking lock	33.1
[33.202] Hydraulic service brakes	33.2
Hydraulic systems.....	35
[35.000] Hydraulic systems.....	35.1
[35.102] Pump control valves.....	35.2
[35.104] Fixed displacement pump.....	35.3
[35.116] Three-point hitch cylinder	35.4
[35.204] Remote control valves	35.5
[35.304] Combination pump units	35.6
Hitches, drawbars, and implement couplings.....	37
[37.110] Rear three-point hitch	37.1
Steering.....	41
[41.101] Steering control	41.1
[41.106] Tie rods.....	41.2
[41.206] Pump.....	41.3
[41.216] Cylinders	41.4

Cab climate control	50
[50.100] Heating	50.1
[50.200] Air conditioning	50.2
Electrical systems	55
[55.000] Electrical system	55.1
[55.011] Fuel tank system	55.2
[55.014] Engine intake and exhaust system	55.3
[55.015] Engine control system	55.4
[55.024] Transmission control system	55.5
[55.031] Parking brake electrical system	55.6
[55.040] Four-Wheel Drive (4WD) control system	55.7
[55.046] Rear axle control system	55.8
[55.048] Rear Power Take-Off (PTO) control system	55.9
[55.050] Heating, Ventilation, and Air-Conditioning (HVAC) control system	55.10
[55.051] Cab Heating, Ventilation, and Air-Conditioning (HVAC) controls	55.11
[55.100] Harnesses and connectors	55.12
[55.201] Engine starting system	55.13
[55.202] Cold start aid	55.14
[55.301] Alternator	55.15
[55.302] Battery	55.16
[55.404] External lighting	55.17
[55.405] External lighting switches and relays	55.18
[55.408] Warning indicators, alarms, and instruments	55.19
[55.510] Cab or platform harnesses and connectors	55.20
[55.512] Cab controls	55.21
[55.513] Cab transmission controls	55.22
[55.514] Cab lighting	55.23
[55.518] Wiper and washer system	55.24

[55.525] Cab engine controls	55.25
[55.640] Electronic modules	55.26
[55.988] Selective Catalytic Reduction (SCR) electrical system	55.27
[55.DTC] FAULT CODES	55.28
Platform, cab, bodywork, and decals	90
[90.100] Engine hood and panels	90.1
[90.110] Operator platform less cab	90.2
[90.114] Operator protections	90.3
[90.124] Pneumatically-adjusted operator seat	90.4
[90.150] Cab	90.5
[90.151] Cab interior	90.6
[90.154] Cab doors and hatches	90.7
[90.156] Cab glazing	90.8
[90.160] Cab interior trim and panels	90.9



INTRODUCTION

Foreword - Important notice regarding equipment servicing

All repair and maintenance work listed in this manual must be carried out only by qualified dealership personnel, strictly complying with the instructions given, and using, whenever possible, the special tools.

Anyone who performs repair and maintenance operations without complying with the procedures provided herein shall be responsible for any subsequent damages.

The manufacturer and all the organizations of its distribution chain, including - without limitation - national, regional, or local dealers, reject any responsibility for damages caused by parts and/or components not approved by the manufacturer, including those used for the servicing or repair of the product manufactured or marketed by the manufacturer. In any case, no warranty is given or attributed on the product manufactured or marketed by the manufacturer in case of damages caused by parts and/or components not approved by the manufacturer.

The manufacturer reserves the right to make improvements in design and changes in specifications at any time without notice and without incurring any obligation to install them on units previously sold. Specifications, descriptions, and illustrative material herein are as accurate as known at time of publication but are subject to change without notice.

In case of questions, refer to your CASE IH Sales and Service Networks.

Safety rules

Personal safety





This is the safety alert symbol. It is used to alert you to potential personal injury hazards. Obey all safety messages that follow this symbol to avoid possible death or injury.

Throughout this manual you will find the signal words DANGER, WARNING, and CAUTION followed by special instructions. These precautions are intended for the personal safety of you and those working with you.

Read and understand all the safety messages in this manual before you operate or service the machine.

 DANGER indicates a hazardous situation that, if not avoided, will result in death or serious injury.

 WARNING indicates a hazardous situation that, if not avoided, could result in death or serious injury.

 CAUTION indicates a hazardous situation that, if not avoided, could result in minor or moderate injury.

FAILURE TO FOLLOW DANGER, WARNING, AND CAUTION MESSAGES COULD RESULT IN DEATH OR SERIOUS INJURY.

Machine safety

NOTICE: Notice indicates a situation that, if not avoided, could result in machine or property damage.

Throughout this manual you will find the signal word Notice followed by special instructions to prevent machine or property damage. The word Notice is used to address practices not related to personal safety.

Information

NOTE: Note indicates additional information that clarifies steps, procedures, or other information in this manual.

Throughout this manual you will find the word Note followed by additional information about a step, procedure, or other information in the manual. The word Note is not intended to address personal safety or property damage.

Safety rules

General safety rules

Use caution when operating the machine on slopes. Raised equipment, full tanks and other loads will change the center of gravity of the machine. The machine can tip or roll over when near ditches and embankments or uneven surfaces.

Never permit anyone other than the operator to ride on the machine.

Never operate the machine under the influence of alcohol, drugs, or while otherwise impaired.

When digging or using ground engaging attachments be aware of buried cables. Contact local utilities to determine the locations of services.

Pay attention to overhead power lines and hanging obstacles. High voltage lines may require significant clearance for safety.

Hydraulic oil or diesel fuel leaking under pressure can penetrate the skin, causing serious injury or infection.

- DO NOT use your hand to check for leaks. Use a piece of cardboard or paper.
- Stop engine, remove key and relieve the pressure before connecting or disconnecting fluid lines.
- Make sure all components are in good condition and tighten all connections before starting the engine or pressurizing the system.
- If hydraulic fluid or diesel fuel penetrates the skin, seek medical attention immediately.
- Continuous long term contact with hydraulic fluid may cause skin cancer. Avoid long term contact and wash the skin promptly with soap and water.

Keep clear of moving parts. Loose clothing, jewelry, watches, long hair, and other loose or hanging items can become entangled in moving parts.

Wear protective equipment when appropriate.

DO NOT attempt to remove material from any part of the machine while it is being operated or components are in motion.

Make sure all guards and shields are in good condition and properly installed before operating the machine. Never operate the machine with shields removed. Always close access doors or panels before operating the machine.

Dirty or slippery steps, ladders, walkways, and platforms can cause falls. Make sure these surfaces remain clean and clear of debris.

A person or pet within the operating area of a machine can be struck or crushed by the machine or its equipment. DO NOT allow anyone to enter the work area.

Raised equipment and/or loads can fall unexpectedly and crush persons underneath. Never allow anyone to enter the area underneath raised equipment during operation.

Never operate engine in enclosed spaces as harmful exhaust gases may build up.

Before starting the machine, be sure that all controls are in neutral or park lock position.

Start the engine only from the operator's seat. If the safety start switch is bypassed, the engine can start with the transmission in gear. Do not connect or short across terminals on the starter solenoid. Attach jumper cables as described in the manual. Starting in gear may cause death or serious injury.

Always keep windows, mirrors, all lighting, and Slow Moving Vehicle (SMV) emblem clean to provide the best possible visibility while operating the machine.

Operate controls only when seated in the operator's seat, except for those controls expressly intended for use from other locations.

Before leaving the machine:

1. Park machine on a firm level surface.
2. Put all controls in neutral or park lock position.
3. Engage park brake. Use wheel chocks if required.
4. Lower all hydraulic equipment — Implements, header, etc.
5. Turn off engine and remove key.

When, due to exceptional circumstances, you would decide to keep the engine running after leaving the operator's station, then the following precautions must be followed:

1. Bring the engine to low idle speed.
2. Disengage all drive systems.

3. **⚠ WARNING**

**Some components may continue to run down after disengaging drive systems.
Make sure all drive systems are fully disengaged.
Failure to comply could result in death or serious injury.**

W0113A

Shift the transmission into neutral.

4. Apply the parking brake.

⚠ General maintenance safety ⚠

Keep area used for servicing the machine clean and dry. Clean up spilled fluids.

Service machine on a firm level surface.

Install guards and shields after servicing the machine.

Close all access doors and install all panels after servicing the machine.

Do not attempt to clean, lubricate, clear obstructions, or make adjustments to the machine while it is in motion or while the engine is running.

Always make sure working area is clear of tools, parts, other persons, and pets before you start operating the machine.

Unsupported hydraulic cylinders can lose pressure and drop the equipment causing a crushing hazard. Do not leave equipment in a raised position while parked or during service, unless securely supported.

Jack or lift the machine only at jack or lift points indicated in this manual.

Incorrect towing procedures can cause accidents. When towing a disabled machine follow the procedure in this manual. Use only rigid tow bars.

Stop the engine, remove key and relieve pressure before disconnecting or connecting fluid lines.

Stop the engine and remove key before disconnecting or connecting electrical connections.

Scalding can result from incorrect removal of coolant caps. Cooling system operates under pressure. Hot coolant can spray out if a cap is removed while the system is hot. Allow system to cool before removing cap. When removing a cap turn it slowly to allow pressure to escape before completely removing the cap.

Replace damaged or worn tubes, hoses, electrical wiring, etc.

Engine, transmission, exhaust components, and hydraulic lines may become hot during operation. Take care when servicing such components. Allow surfaces to cool before handling or disconnecting hot components. Wear protective equipment when appropriate.

When welding, follow the instructions in the manual. Always disconnect the battery before welding on the machine. Always wash your hands after handling battery components.



SERVICE MANUAL

Engine

Farmall® 110A 110 HP TIER 4B (final) engine, 2WD, and ROPS. , Farmall® 110A 110 HP TIER 4B (final) engine, 2WD, and cab. , Farmall® 110A 110 HP TIER 4B (final) engine, 4WD, and ROPS. , Farmall® 110A 110 HP TIER 4B (final) engine, 4WD, and cab. , Farmall® 120A 119 HP TIER 4B (final) engine, 2WD, and ROPS. , Farmall® 120A 119 HP TIER 4B (final) engine, 2WD, and cab. , Farmall® 120A 119 HP TIER 4B (final) engine, 4WD, and ROPS. , Farmall® 120A 119 HP TIER 4B (final) engine, 4WD, and cab. , Farmall® 130A 130 HP TIER 4B (final) engine, 2WD, and ROPS. , Farmall® 130A 130 HP TIER 4B (final) engine, 2WD, and cab. , Farmall® 130A 130 HP TIER 4B (final) engine, 4WD, and ROPS. , Farmall® 130A 130 HP TIER 4B (final) engine, 4WD, and cab. , Farmall® 140A 139 HP TIER 4B (final) engine, 2WD, and ROPS. , Farmall® 140A 139 HP TIER 4B (final) engine, 2WD, and cab. , Farmall® 140A 139 HP TIER 4B (final) engine, 4WD, and ROPS. , Farmall® 140A 139 HP TIER 4B (final) engine, 4WD, and cab.

Engine - Remove

⚠ WARNING

Avoid injury!

Handle all parts carefully. Do not place your hands or fingers between parts. Use Personal Protective Equipment (PPE) as indicated in this manual, including protective goggles, gloves, and safety footwear.

Failure to comply could result in death or serious injury.

W0208A

⚠ WARNING

Heavy objects!

Lift and handle all heavy components using lifting equipment with adequate capacity. Always support units or parts with suitable slings or hooks. Make sure the work area is clear of all bystanders.

Failure to comply could result in death or serious injury.

W0398A

Prior operation:

Air conditioning - Recover (50.200)

Prior operation:

Battery - Disconnect (55.302)

Prior operation:

Engine cooling system - Drain fluid (10.400)

Prior operation:

Hood - Remove (90.100)

Prior operation:

Axle support - Remove (Front support and front axle) – Standard-duty (25.100)

Prior operation:

Engine - Disconnect (10.001)

1. Install wheel chocks in front of and behind the rear wheels.
2. Remove the Selective Catalytic Reduction (SCR) muffler and catalyst upper front cover retaining bolts (1) and (2).
3. Remove the SCR muffler and catalyst upper front cover (3).

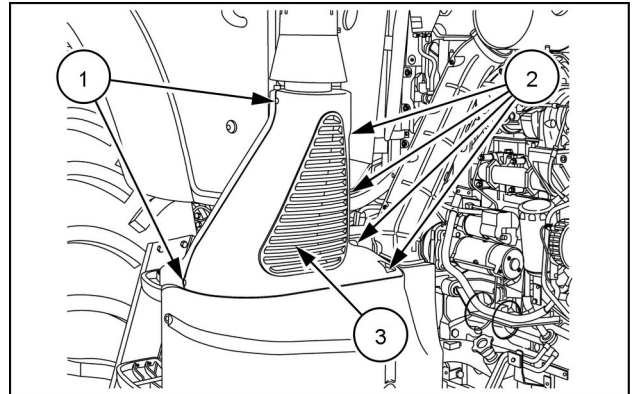

NHIL15TR00033AA 1

4. Remove the SCR muffler and catalyst upper rear cover retaining bolts (1).

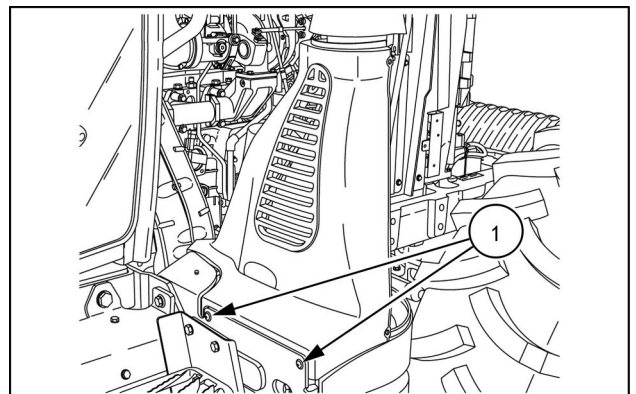

NHIL15TR00264AA 2

5. Detach the SCR muffler and catalyst emissions sensors wiring harness (1) from the cover clips (2).
6. Remove the SCR muffler and catalyst upper rear cover (3).

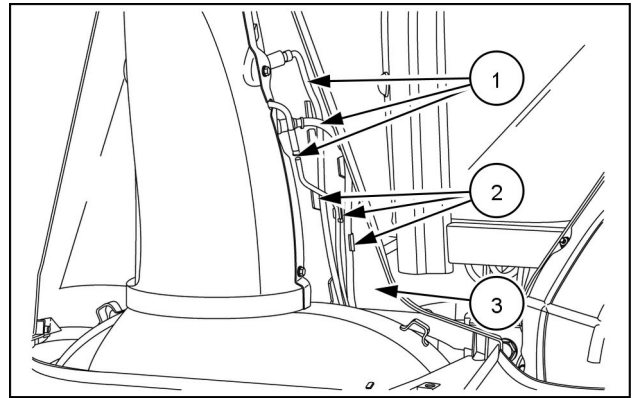

NHIL15TR00256AA 3

7. Remove the SCR muffler and catalyst lower cover retaining bolts (2).
8. Remove the SCR muffler and catalyst lower cover (1).

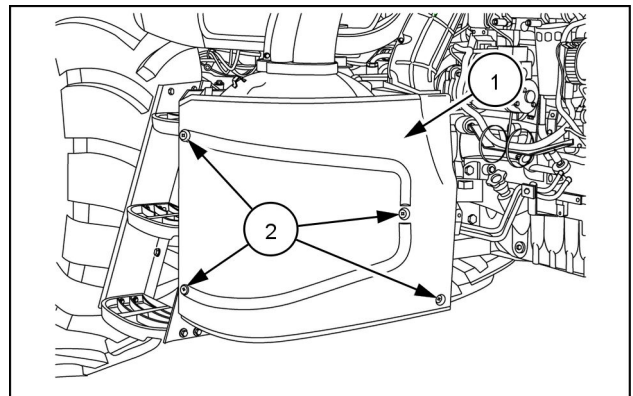

NHIL15TR00020AA 4

9. Remove the six SCR muffler and catalyst heat shield retaining bolts (1) and (2).
10. Remove the SCR muffler and catalyst lower heat shield (3).

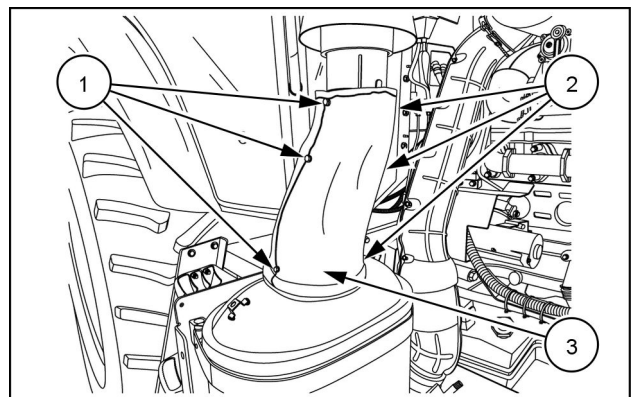

NHIL15TR00089AA 5

11. Move backward the SCR muffler and catalyst upper heat shield (1).
12. Remove the SCR muffler and catalyst emissions sensors from the SCR muffler and catalyst (4), as follows:
 - Remove the downstream Nitrogen oxide (NOx) sensor (2).
 - Remove the Ammonia (NH3) sensor (3).
 - Remove the SCR muffler and catalyst downstream temperature sensor (5).
13. Remove the SCR muffler and catalyst upper heat shield.

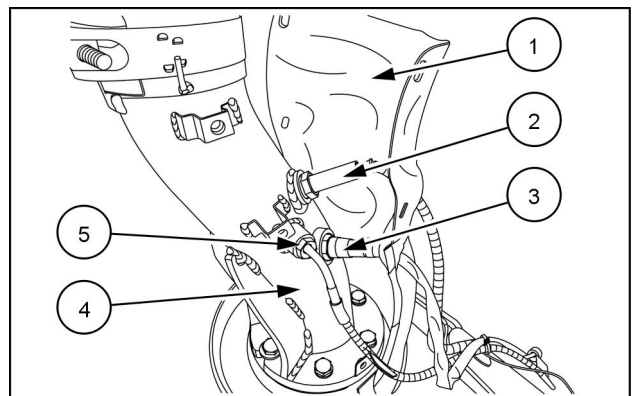

NHIL15TR00263AA 6

14. Remove the clamps **(2)** that secure the SCR muffler and catalyst exhaust outlet pipe **(1)**.
15. Remove the SCR muffler and catalyst exhaust outlet pipe.

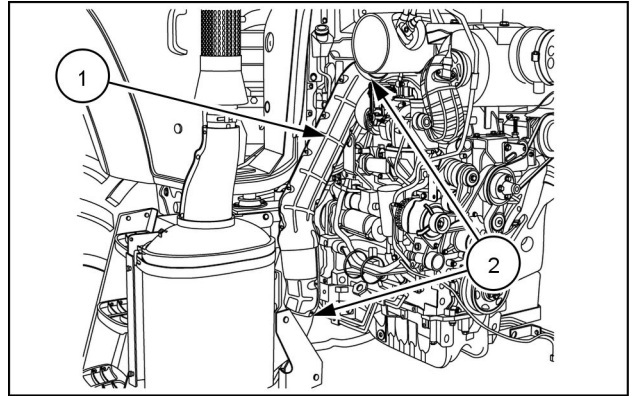

NHIL15TR00010AA 7

16. Remove the two clamps **(2)** that secure the air cleaner to turbo air duct **(1)**.
17. Remove the air duct.

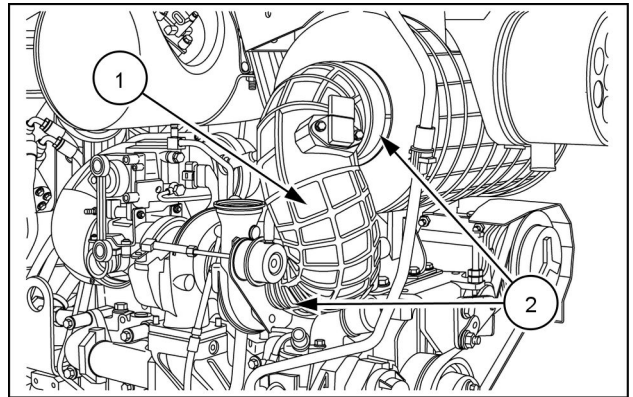

NHIL15TR00008AA 8

18. Remove the two bolts **(1)** from the Crank Case Ventilation (CCV) filter **(2)**.
19. Remove the CCV filter.

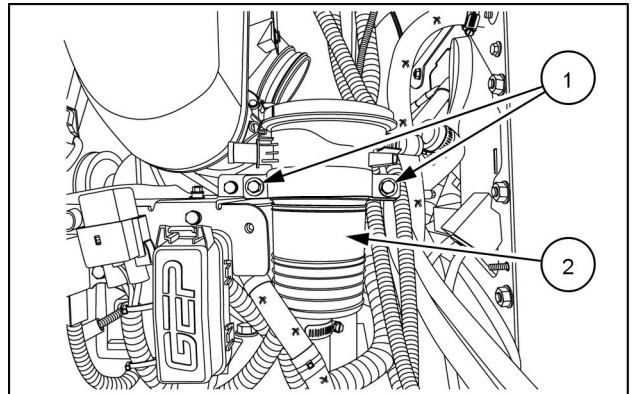

NHIL15TR00072AA 9

20. Remove the three air cleaner retaining bolts **(3)**.
21. Remove the air cleaner **(2)** from the hood support **(1)**.

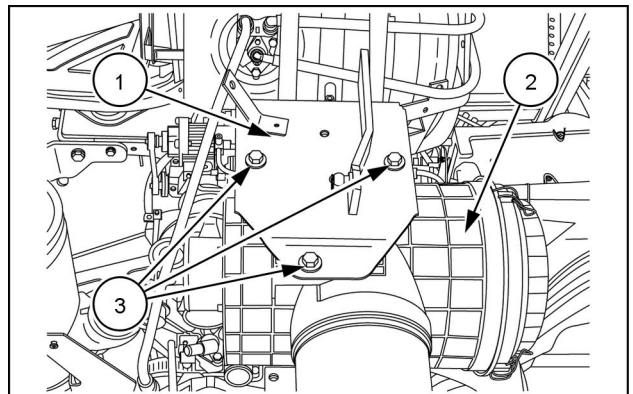

NHIL15TR00005AA 10

22. Remove the wiring harness (4) and the **DIESEL EXHAUST FLUID (DEF)/AdBLUE®** and coolant lines (1) from the hood support (2).

NOTE: Some cable ties (3) need to be removed before removing the wiring harness and the **DEF/AdBLUE®** and coolant lines.

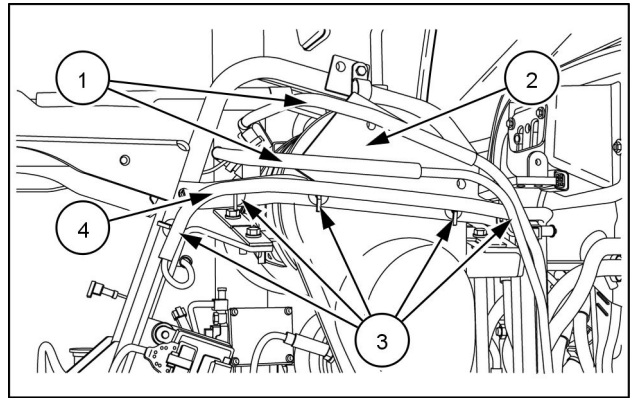

NHIL15TR00060AA 11

23. Remove the fuse holder support retaining bolt (2).
24. Remove the fuse holder support (1) from the hood support (3).

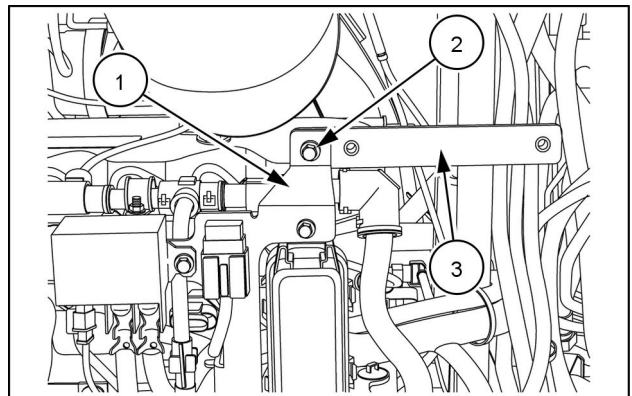

NHIL15TR00044AA 12

25. Remove the clamp (3) from the exhaust pipe (1).
26. Disconnect the exhaust pipe from the exhaust flap (2).

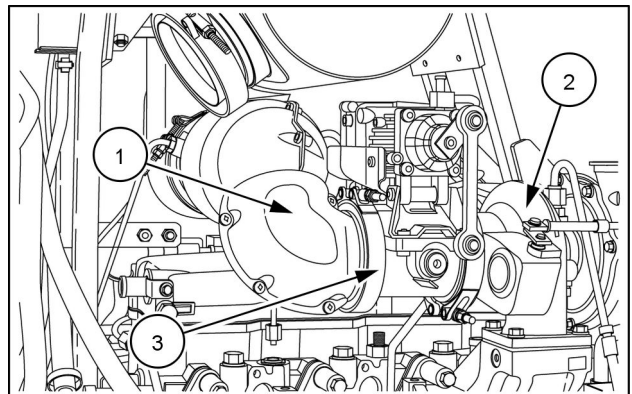

NHIL15TR00048AA 13

27. Remove the four retaining bolts (2) from the rear part of the hood support (1).

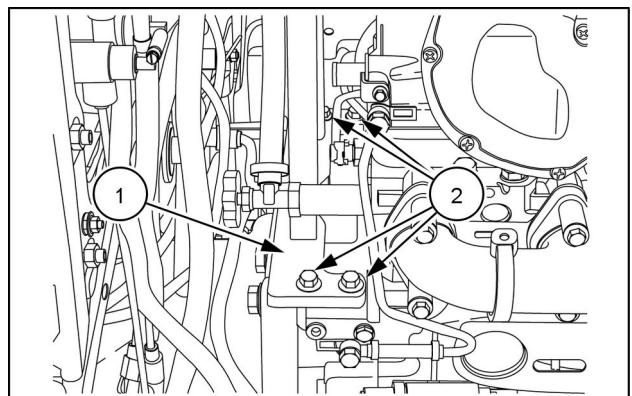

NHIL15TR00047AA 14

28. Remove the two retaining bolts (2) from the front part of the hood support (1).

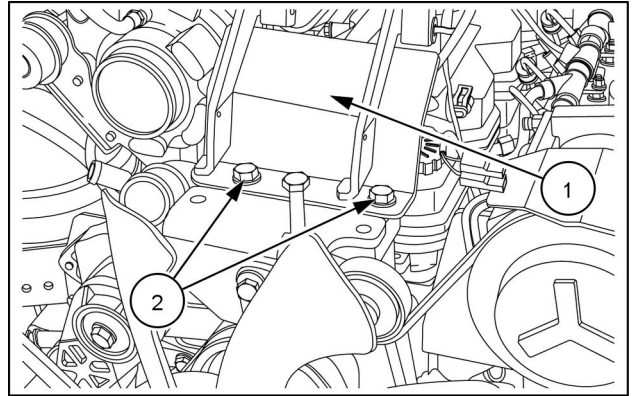

NHIL15TR00046AA 15

29. Use a suitable lifting device (1) and a suitable sling (3) to remove the hood support with the Diesel Oxidation Catalyst (DOC) assembly (2).

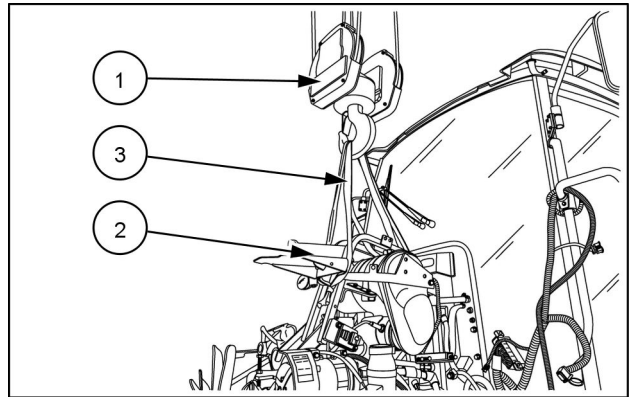

NHIL15TR00078AA 16

30. Cut the cable ties (3) that secure the wiring harness (2) and the heating return hose (1).
31. Remove the wire harness and the hose from the support.

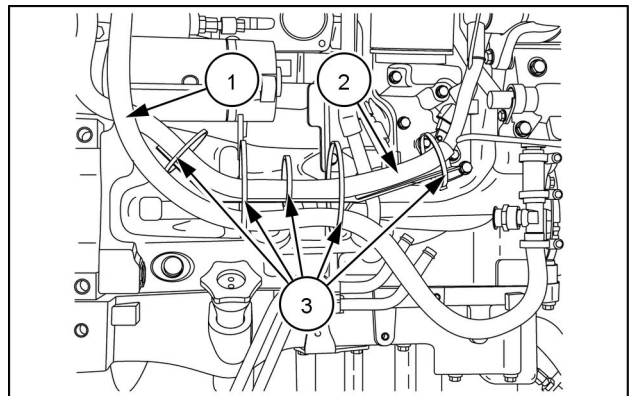

NHIL15TR00039AA 17

32. Remove the two bolts (2) from the support (1).
33. Remove the support from the engine.

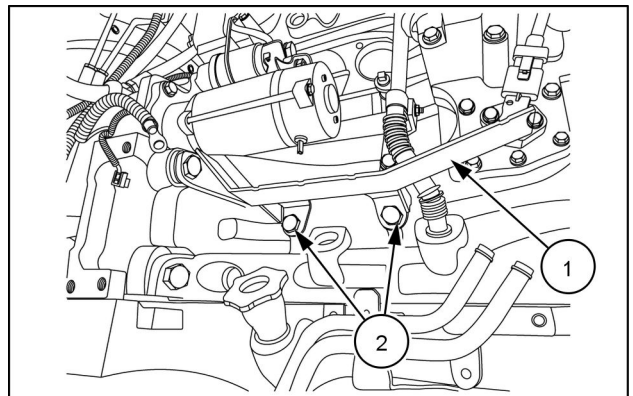

NHIL15TR00080AA 18

34. Remove the clamp **(3)** that secures the hydraulic tube **(2)** to the auxiliary pump **(1)**.
35. Remove the hydraulic tube.

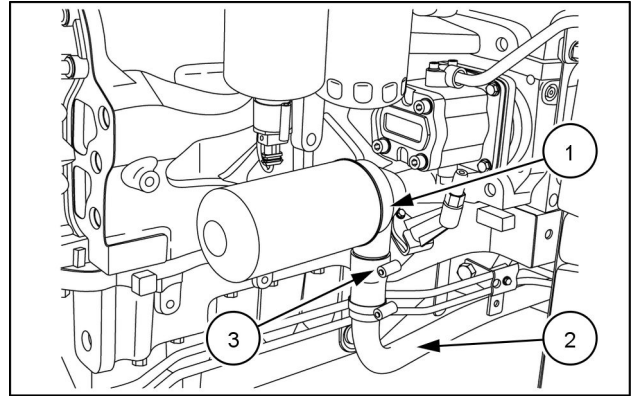

NHIL15TR00038AA 19

36. Remove the two hydraulic tube retaining bolts **(1)**.
37. Remove the hydraulic tube **(2)** from the auxiliary pump **(3)**.

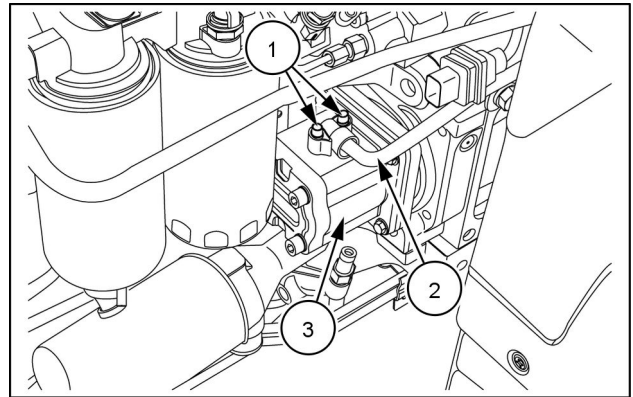

NHIL15TR00037AA 20

38. Remove the two coolant control valve support retaining bolts **(2)**.
39. Remove the support **(1)** with the coolant control valve assembly.

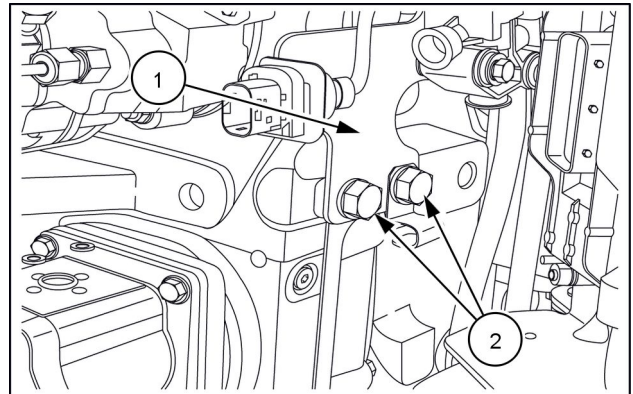

NHIL15TR00045AA 21

40. Remove the bolt **(2)** from the clamp **(1)** that secure the steering pump pipes **(3)**.

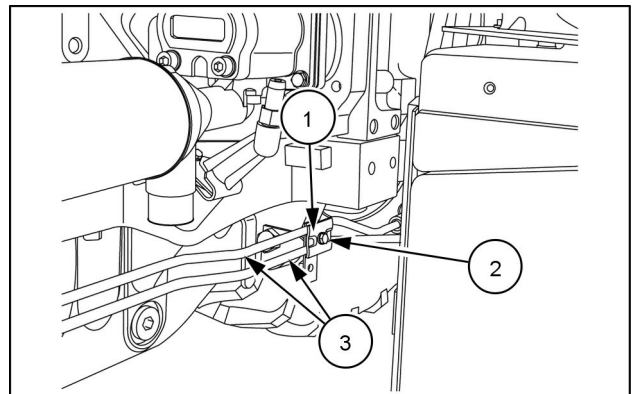

NHIL15TR00053AA 22

41. Remove the bolts (3) from the clamps (1) that secure the transmission cooler lines (2).
42. Remove the lines from the engine.

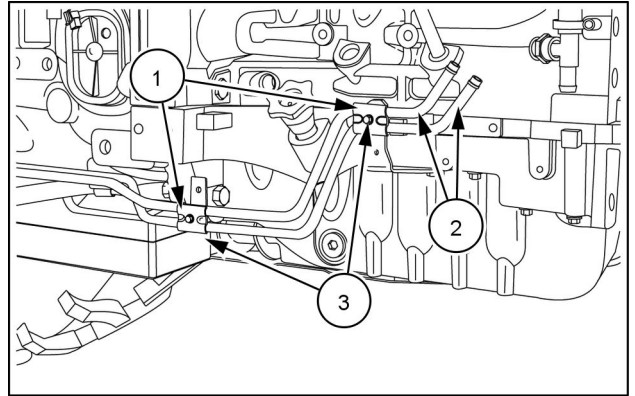

NHIL15TR00056AA 23

43. Use a suitable lifting device (1) and an engine stand (2) to support the engine.
44. Raise the engine and slide the splitting kit under the transmission in order to rest the weight of the tractor on the support.

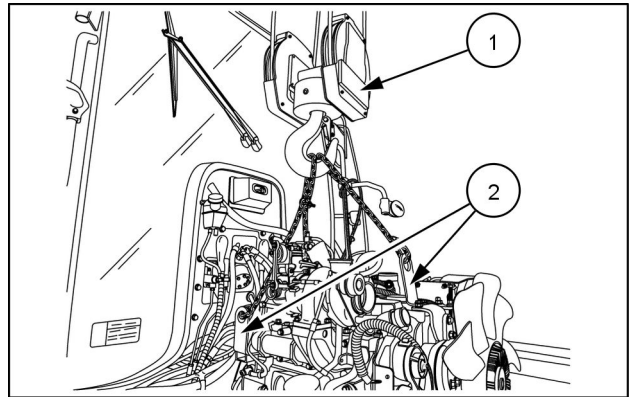

NHIL15TR00079AA 24

45. Remove the four lower engine to transmission mounting bolts (1).

NOTE: Before you remove the mounting bolts, mark the position for installation at a later time

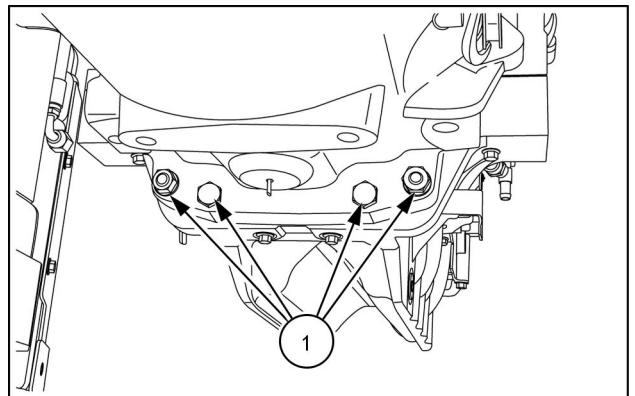

NHIL15TR00050AA 25

46. Remove the two bolts (1) on the left-hand side of the engine.

NOTE: Before you remove the mounting bolts, mark the position for installation at a later time

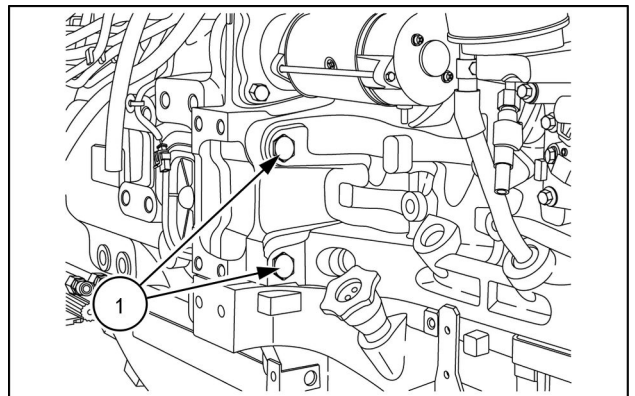

NHIL15TR00049AA 26

47. Remove the two bolts (1) on the right-hand side of the engine.

NOTE: Before you remove the mounting bolts, mark the position for installation at a later time

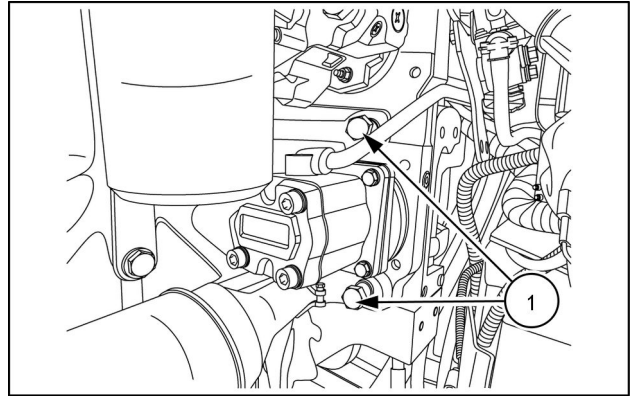

NHIL15TR00081AA 27

48. Remove the three upper engine to transmission mounting bolts (1).

NOTE: Before you remove the mounting bolts, mark the position for installation at a later time

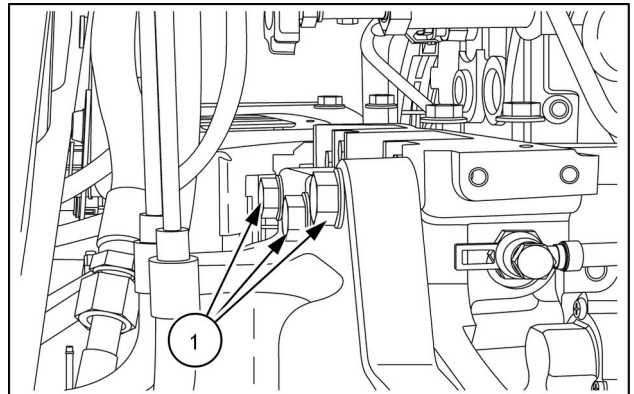

NHIL15TR00057AA 28

49. Separate the engine (1) from the transmission.
50. Remove the engine from the tractor.

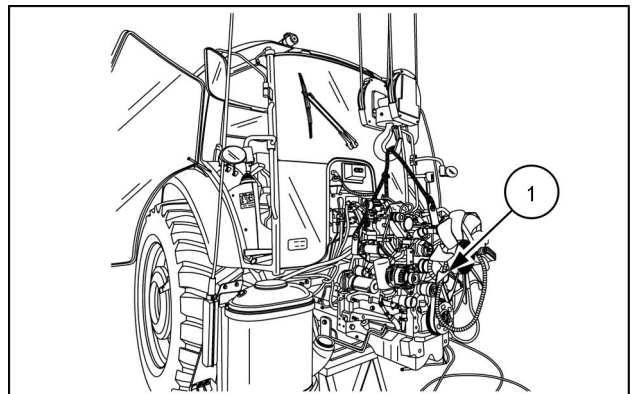

NHIL15TR00082AA 29

Next operation:
Engine - Install (10.001)

Engine - Install

⚠ WARNING

Avoid injury!

Handle all parts carefully. Do not place your hands or fingers between parts. Use Personal Protective Equipment (PPE) as indicated in this manual, including protective goggles, gloves, and safety footwear.

Failure to comply could result in death or serious injury.

W0208A

⚠ WARNING

Heavy objects!

Lift and handle all heavy components using lifting equipment with adequate capacity. Always support units or parts with suitable slings or hooks. Make sure the work area is clear of all bystanders.

Failure to comply could result in death or serious injury.

W0398A

Prior operation:
Engine - Remove (10.001)

1. ⚠ DANGER

Heavy parts!

Support designated component(s) with adequate lifting equipment.

Failure to comply will result in death or serious injury.

D0018A

⚠ CAUTION

Pinch hazard!

Always use suitable tools to align mating parts. DO NOT use your hand or fingers.

Failure to comply could result in minor or moderate injury.

C0044A

Use an appropriate lifting device (1) to align the engine to the transmission, as shown. Make sure that the two locating dowel pins are correctly positioned.

NOTICE: Make sure that no harness, or lines are between the engine and transmission flanges.

2. Install the two M16 x 130, and the M16 x 70 upper engine to transmission mounting bolts (1) in the same marked position as previously removed.

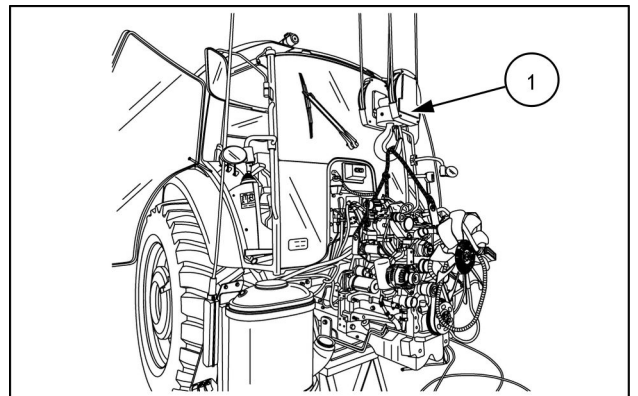

NHIL15TR00082AA 1

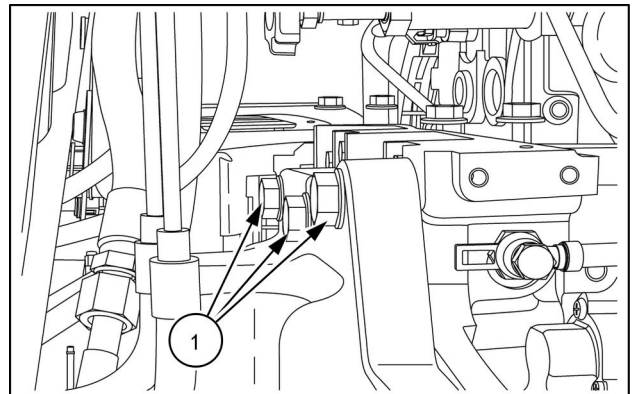

NHIL15TR00057AA 2

3. Install the two M16 x 140 engine to transmission mounting bolts (1) on the right-hand side, in the same marked position as previously removed.

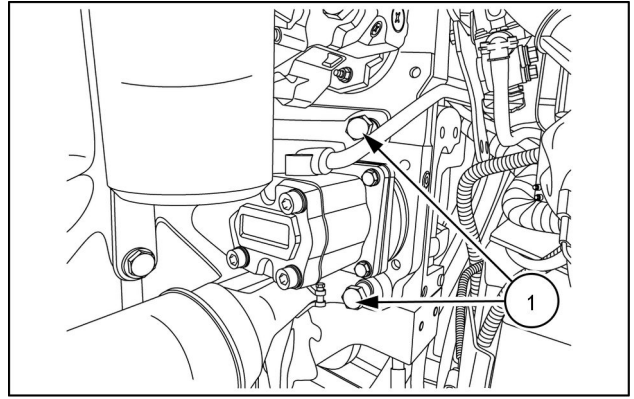

NHIL15TR00081AA 3

4. Install the two M16 x 140 engine to transmission mounting bolts (1) on the left-hand side, in the same marked position as previously removed.

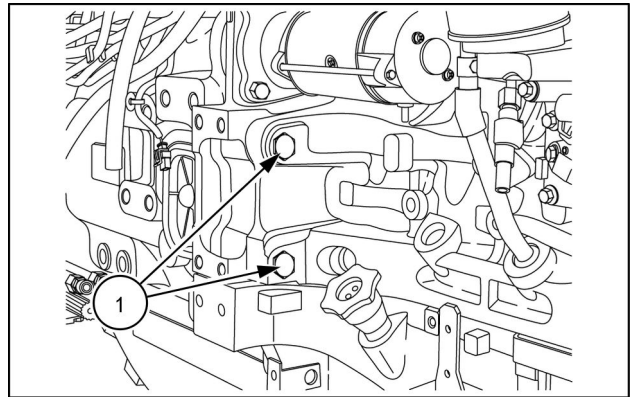

NHIL15TR00049AA 4

5. Install the two M16 x 90, and the two M16 x 70 lower engine to transmission mounting bolts (1) in the same marked position as previously removed.
6. Torque the M16 hardware bolts to **210 - 285 N·m (155 - 210 lb ft)**.

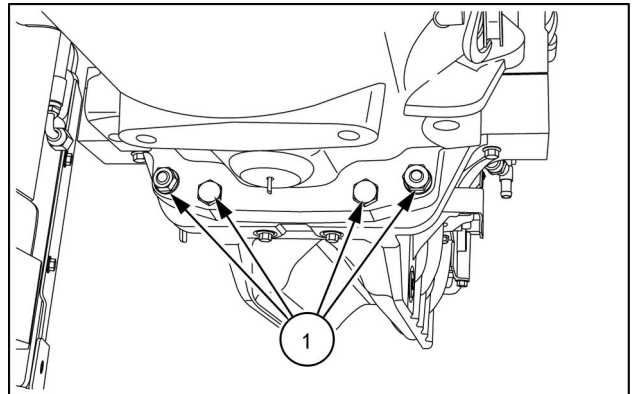

NHIL15TR00050AA 5

7. Raise the tractor and reposition the splitting kit underneath the engine in order to rest the weight of the tractor on the support.
8. Remove the engine stand (2) and the lifting device (1).

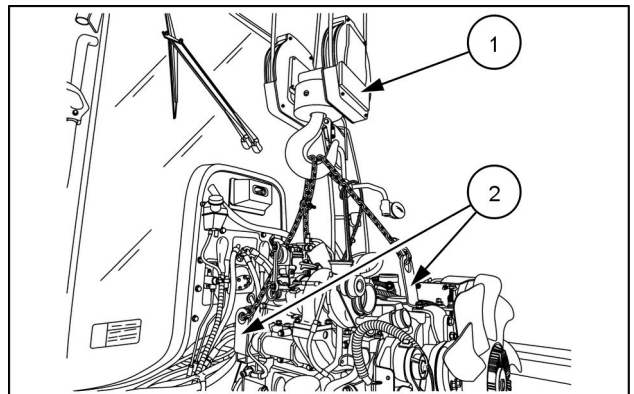

NHIL15TR00079AA 6

9. Install the transmission cooler lines to the engine (2).
10. Secure the cooler lines by installing the clamps (1) and the M6 bolts (3).

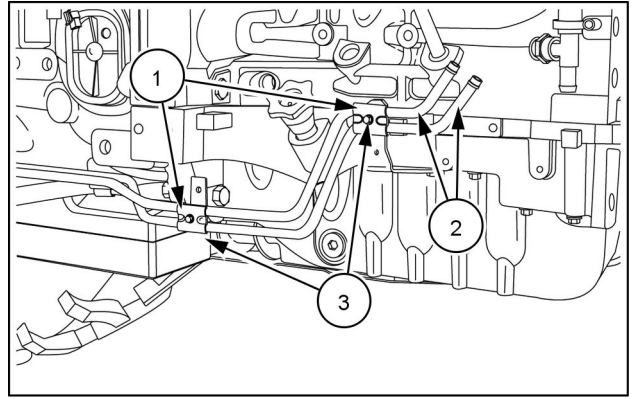

NHIL15TR00056AA 7

11. Secure the steering pump pipes (3) by installing the clamp (1) and the M6 bolt (2).

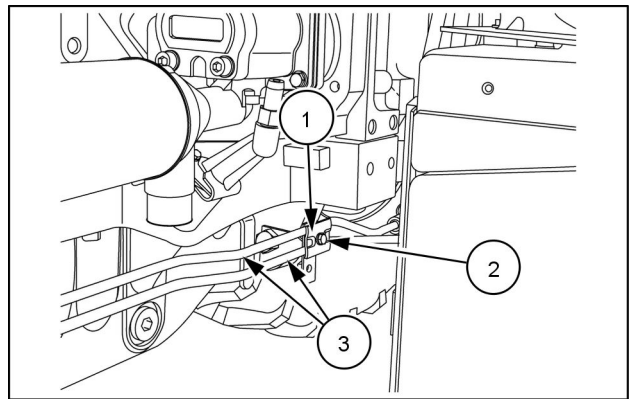

NHIL15TR00053AA 8

12. Install the coolant control valve support (1) with the coolant control valve assembly.
13. Install the two M14 retaining bolts (2) that secures the coolant control valve support.
14. Torque the two bolts to **99 - 108 N·m (73 - 80 lb ft)**.

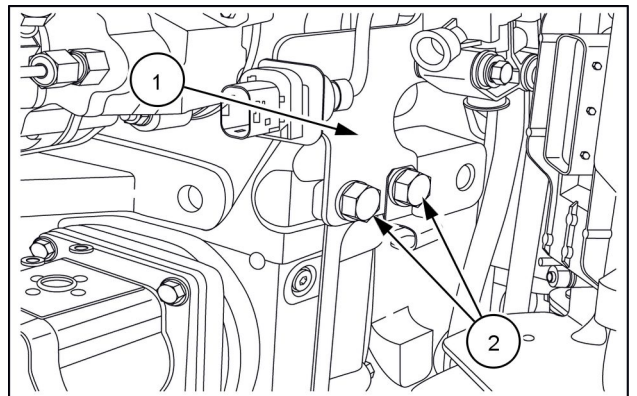

NHIL15TR00045AA 9

15. Install the hydraulic tube (2) to the auxiliary pump (3).
16. Install the two M6 bolts (1) that secure the hydraulic tube.
17. Torque the bolts to **10.0 - 13.0 N·m (7.4 - 9.6 lb ft)**.

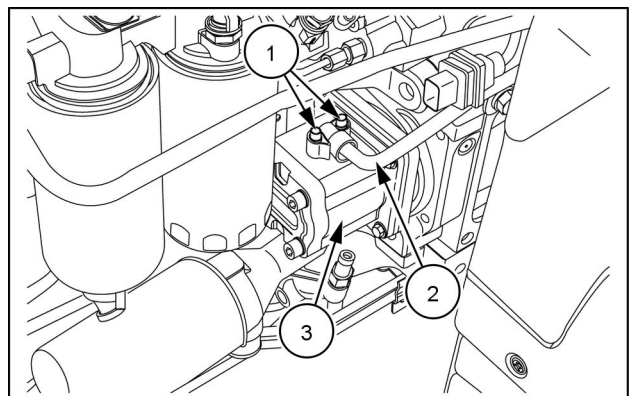

NHIL15TR00037AA 10

18. Install the hydraulic tube (2) to the auxiliary pump (1).
19. Secure the tube by installing the clamps (3).

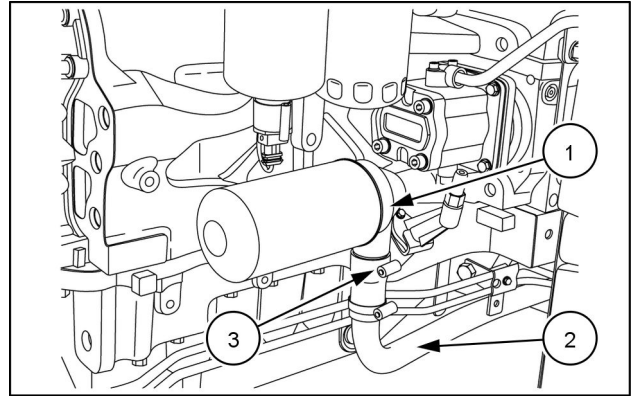

NHIL15TR00038AA 11

20. Install the support (1) to the engine.
21. Install the two M12 support retaining bolts (2).
22. Torque the bolts to **85 - 115 N·m (63 - 85 lb ft)**.

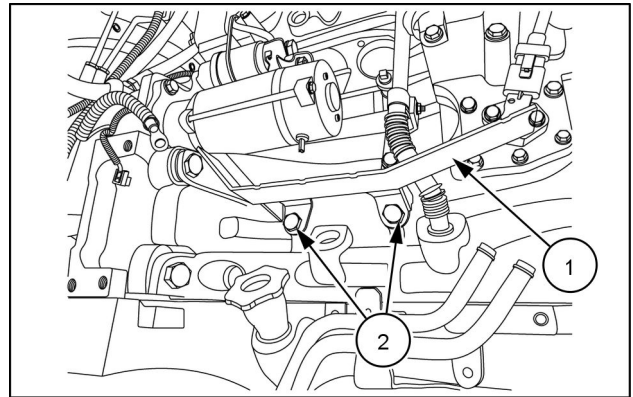

NHIL15TR00080AA 12

23. Guide the wiring harness (2) onto the support installed in the previous step.
24. Use new cable ties (3) to secure the wiring harness and the heating return hose (1).

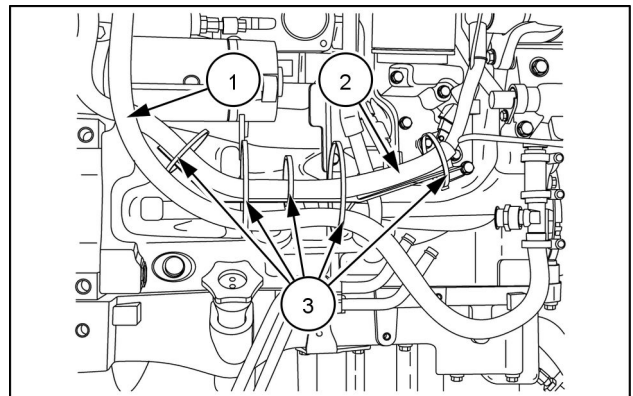

NHIL15TR00039AA 13

25. Use a suitable lifting device (1) and a suitable sling (3) to install the hood support with the Diesel Oxidation Catalyst (DOC) assembly (2).

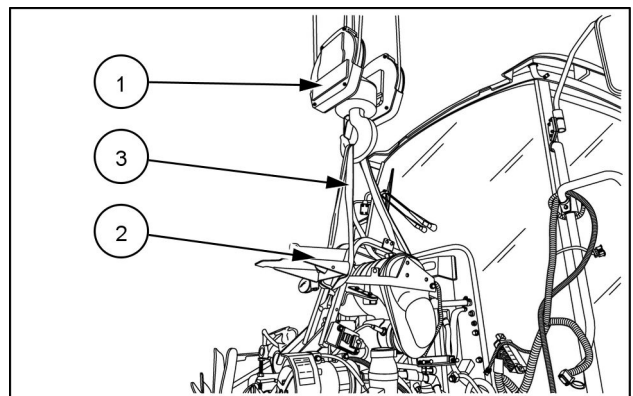

NHIL15TR00078AA 14

26. Install the two M10 retaining bolts (2) to the front part of the hood support (1).

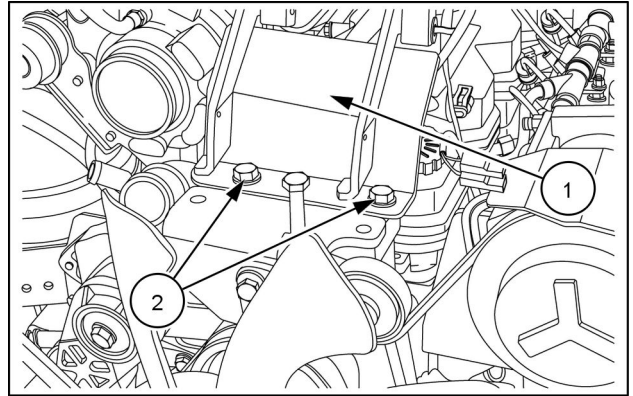

NHIL15TR00046AA 15

27. Install the four M10 retaining bolts (2) to the rear of the hood support (1).
28. Torque the M10 hardware bolts to **53 - 72 N·m (39 - 53 lb ft)**.

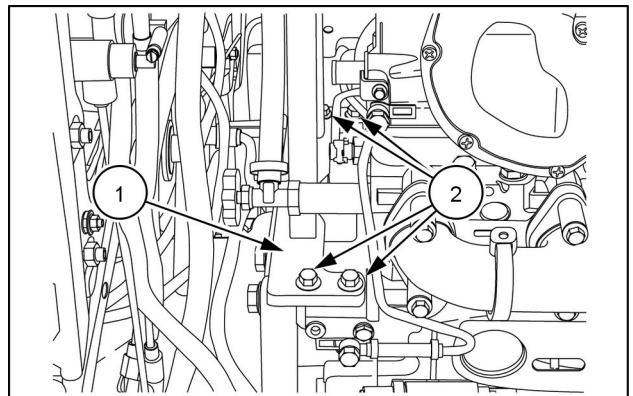

NHIL15TR00047AA 16

29. Connect the exhaust pipe (1) to the exhaust flap (2).
30. Secure the exhaust pipe with the clamp (3).

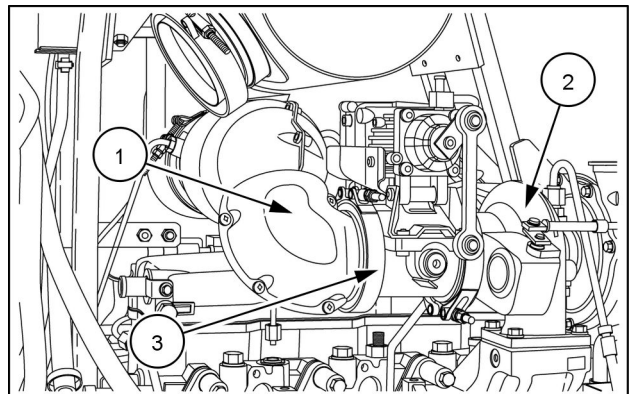

NHIL15TR00048AA 17

31. Install the fuse holder support (1) to the hood support (3).
32. Install the M10 retaining bolt (2) that secure the fuse holder support.

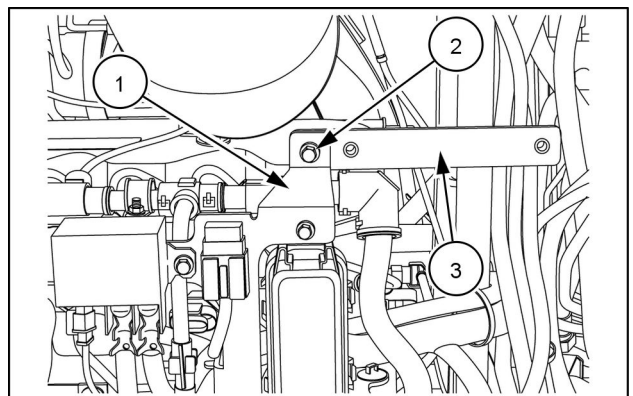

NHIL15TR00044AA 18

33. Secure the wiring harness (4) and the **DIESEL EXHAUST FLUID (DEF)/AdBLUE®** and coolant lines (1) to the hood support (2) by installing new cables ties (3).

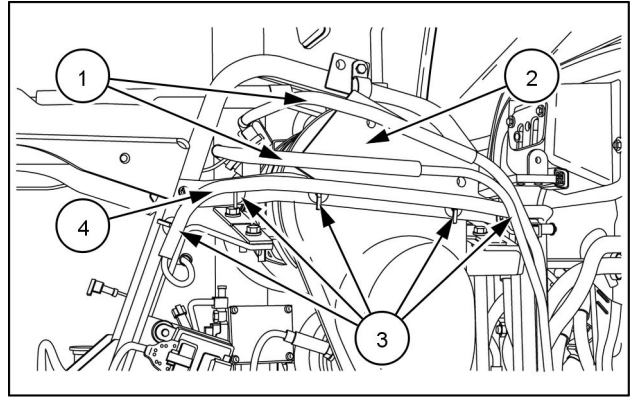

NHIL15TR00060AA 19

34. Install the air cleaner (2) to the hood support (1).
 35. Install the three M10 air cleaner retaining bolts (3).
 36. Torque the bolts to **48 - 65 N·m (35 - 48 lb ft)**.

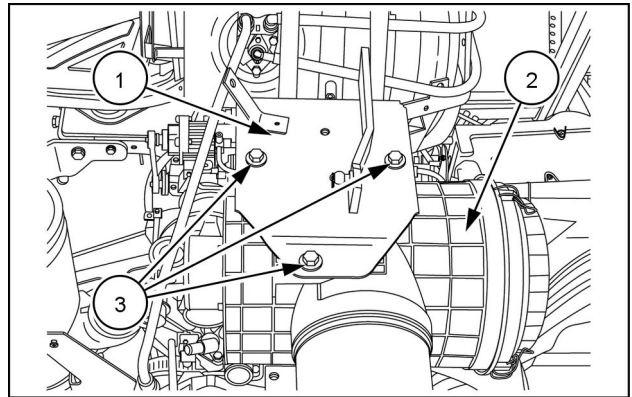

NHIL15TR00055AA 20

37. Install the Crank Case Ventilation (CCV) filter (2) to the hood support.
 38. Install the two M8 retaining bolts (1) that secure the CCV filter.
 39. Torque the bolts to **24 - 33 N·m (18 - 24 lb ft)**.

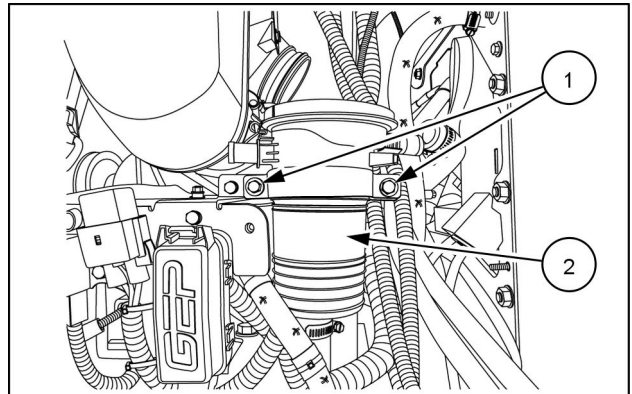

NHIL15TR00072AA 21

40. Install the air cleaner to turbo air duct (1).
 41. Secure the air duct by installing the two clamps (2).

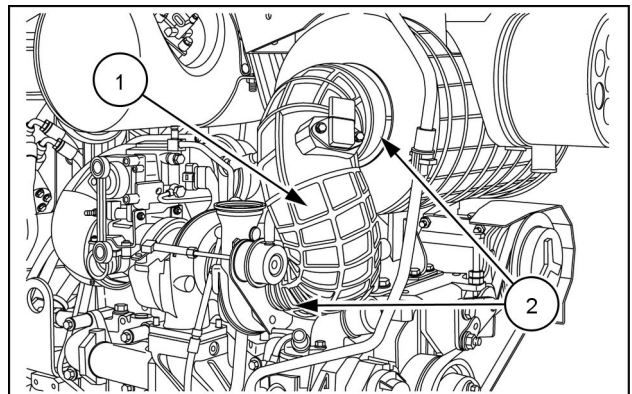

NHIL15TR00088AA 22

- 42. Install the Selective Catalytic Reduction (SCR) exhaust outlet pipe (4) to the SCR muffler and catalyst (3) and to the DOC (1).
- 43. Secure the exhaust outlet pipe by installing the clamps (2).

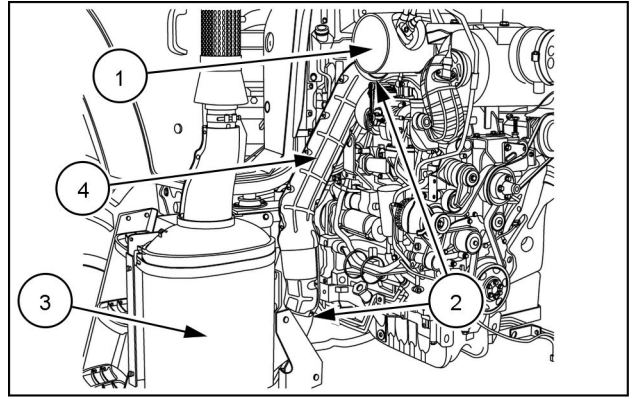

NHIL15TR00010AA 23

- 44. Install the SCR muffler and catalyst lower cover (1).
- 45. Install the SCR muffler and catalyst lower cover retaining bolts (2).

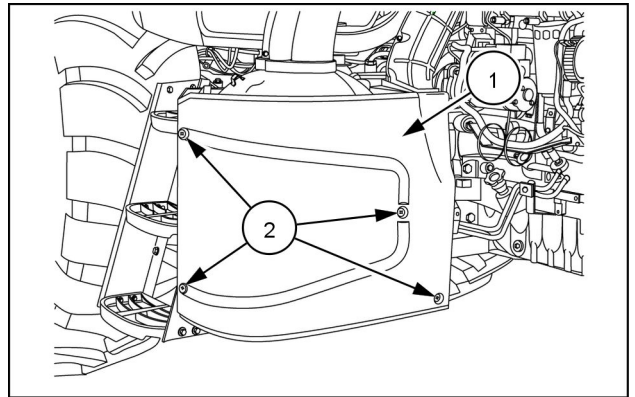

NHIL15TR00020AA 24

- 46. Install the SCR muffler and catalyst upper rear cover (3).
- 47. Attach the SCR muffler and catalyst emissions sensors wiring harness (1) to the cover clips (2).

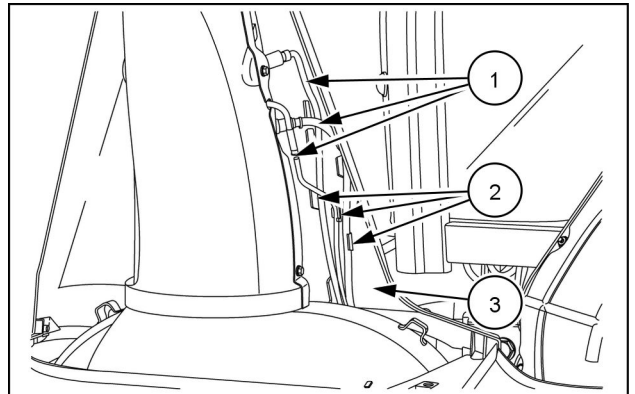

NHIL15TR00256AA 25

- 48. Install the SCR muffler and catalyst upper rear cover retaining bolts (1).

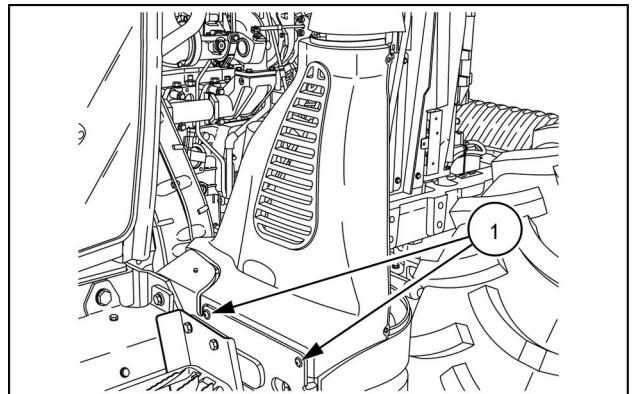

NHIL15TR00264AA 26

49. Install the SCR muffler and catalyst upper front cover (3).
50. Install the SCR muffler and catalyst upper front cover retaining bolts (1) and (2).

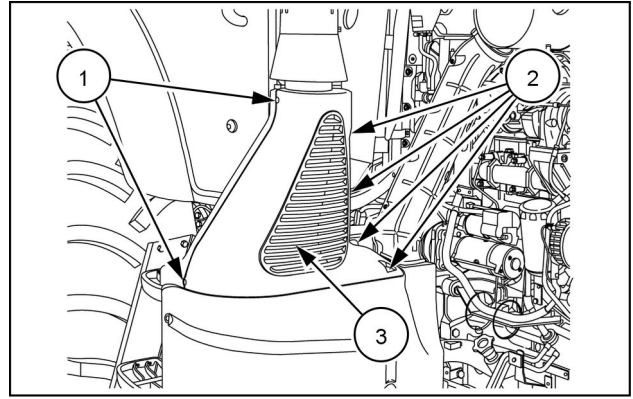

NHIL15TR00033AA 27

Next operation:

Engine - Connect (10.001)

Next operation:

Axle support - Install (Front support and front axle) – Standard-duty (25.100)

Next operation:

Hood - Install (90.100)

Next operation:

Engine cooling system - Filling (10.400)

Next operation:

Battery - Connect (55.302)

Next operation:

Air conditioning - Charging (50.200)

Engine - Disconnect

⚠ WARNING

Avoid injury!

Handle all parts carefully. Do not place your hands or fingers between parts. Use Personal Protective Equipment (PPE) as indicated in this manual, including protective goggles, gloves, and safety footwear.

Failure to comply could result in death or serious injury.

W0208A

⚠ WARNING

Heavy objects!

Lift and handle all heavy components using lifting equipment with adequate capacity. Always support units or parts with suitable slings or hooks. Make sure the work area is clear of all bystanders.

Failure to comply could result in death or serious injury.

W0398A

Prior operation:

Air conditioning - Recover (50.200)

Prior operation:

Battery - Disconnect (55.302)

Prior operation:

Engine cooling system - Drain fluid (10.400)

Prior operation:

Hood - Remove (90.100)

Prior operation:

Axle support - Remove (Front support and front axle) – Standard-duty (25.100)

NOTE: Some components were removed from the images for better clarity.

1. Install wheel chocks in front of and behind the rear wheels.
2. Remove the solenoid cover retaining nut (2).
3. Remove the solenoid cover (1) from the starter motor M-003 (3).

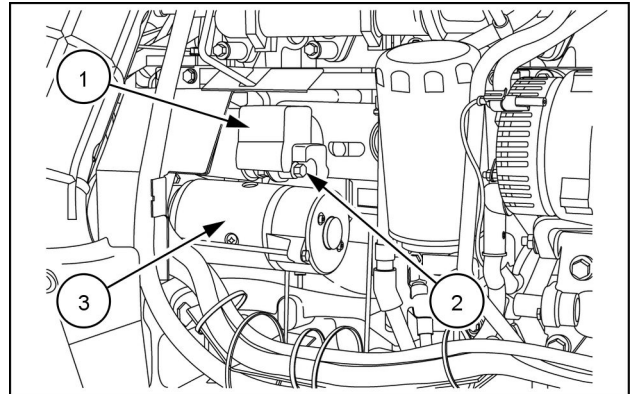

NHIL15TR00032AA 1

4. Remove the two starter cover retaining bolts (1) and the starter motor mounting bolt (3).
5. Remove the starter cover (2).

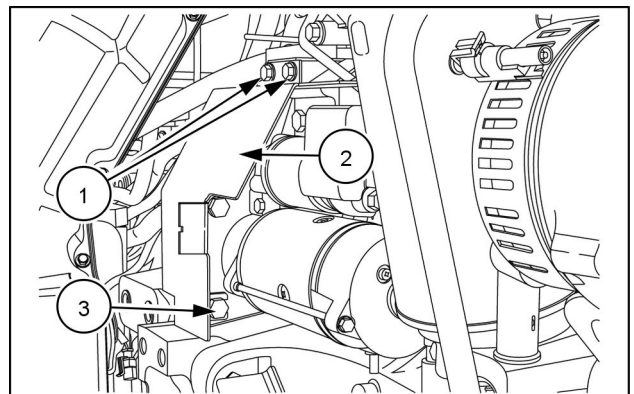

NHIL15TR00299AA 2

6. Remove the starter motor mounting bolt (2) to disconnect the main ground **GND-001** wire connectors **X-214** and **X-214A** (1).

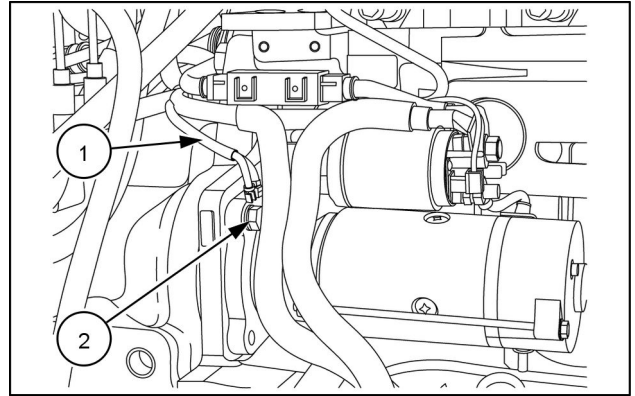

NHIL15TR00295AA 3

7. Disconnect the wiring harness from the starter solenoid (6):
 - A. Remove the nut (4).
 - B. Remove the wiring harness connector **X-231C** (2).
 - C. Remove the engine wiring harness connector **X-180** (3).
 - D. Remove the positive battery cable connector **X-231A** (1).
8. Disconnect the positive electrical connector **X-162** (5) from the starter solenoid.

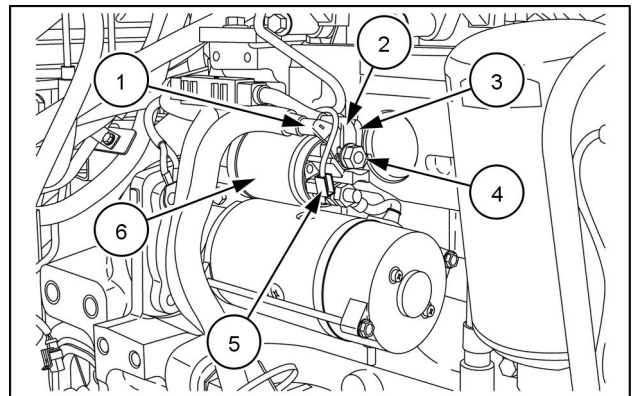

NHIL15TR00298AA 4

9. Remove the two clamps (3) that secure the hoses (1) to the Crank Case Ventilation (CCV) filter (2).
10. Disconnect the two hoses from the CCV filter.

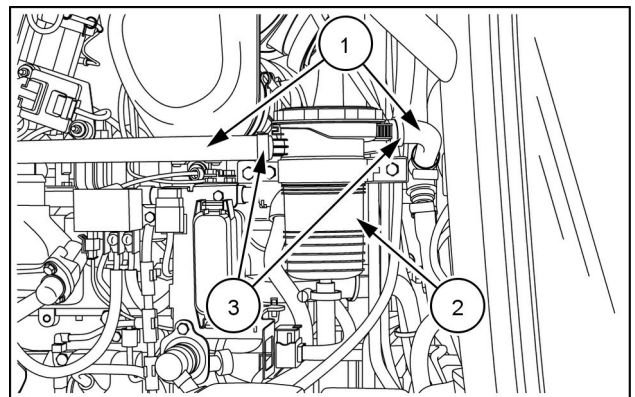

NHIL15TR00040AA 5

11. Remove the clamp (1) that secures the rear CCV hose (3) to the aims cover (2).
12. Disconnect the CCV hose.

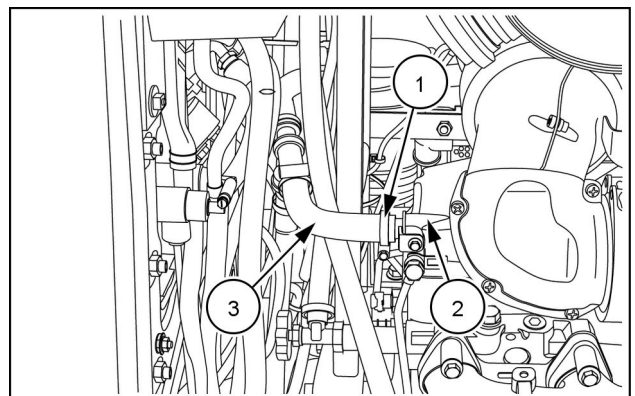

NHIL15TR00052AA 6

13. Remove the clamp **(2)** that secures the CCV hose **(1)** to the CCV engine fitting **(3)**.
14. Disconnect the CCV hose.

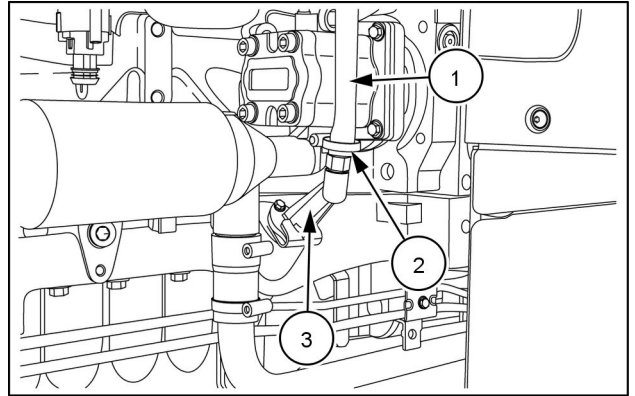

NHIL15TR00041AA 7

15. Disconnect the electrical connector **X-908 (1)** from the humidity sensor **B-043 (2)**, which is located onto the air cleaner to turbo air duct **(2)**.

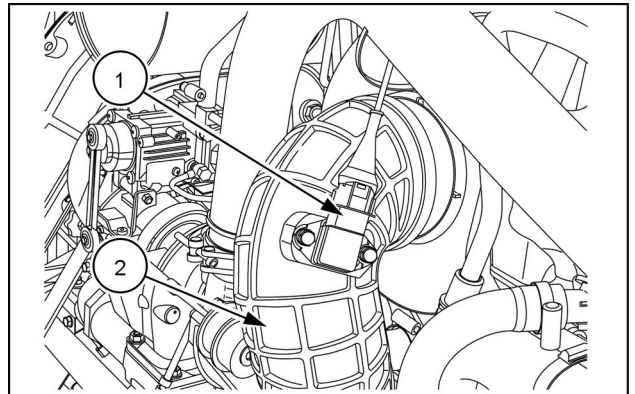

NHIL15TR00232AA 8

16. Disconnect the electrical connector **X-224 (1)** from the air cleaner switch **S-026 (2)**.

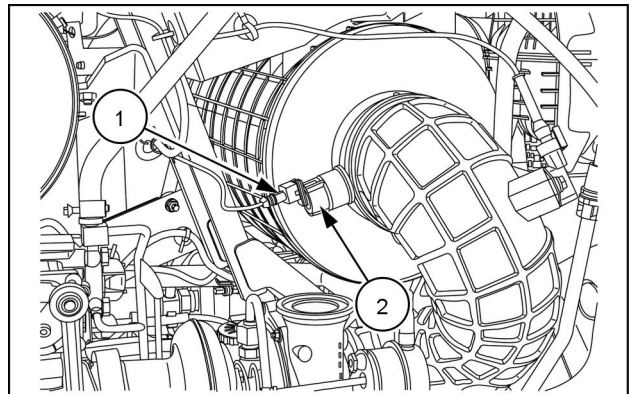

NHIL15TR00382AA 9

17. Disconnect the two connectors **(2)** from the cooling hose assembly **(1)**.
18. Remove the cooling hose assembly.

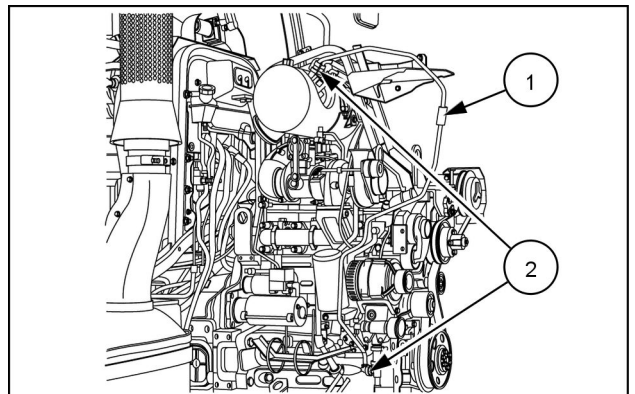

NHIL15TR00007AA 10



Suggest:

If the above button click is invalid.

Please download this document

first, and then click the above link

to download the complete manual.

Thank you so much for reading

19. Disconnect the **DIESEL EXHAUST FLUID (DEF)/ ADBLUE®** dosing module electrical connector **X-904 (1)** from the **DEF/ADBLUE®** dosing module **B-008**.

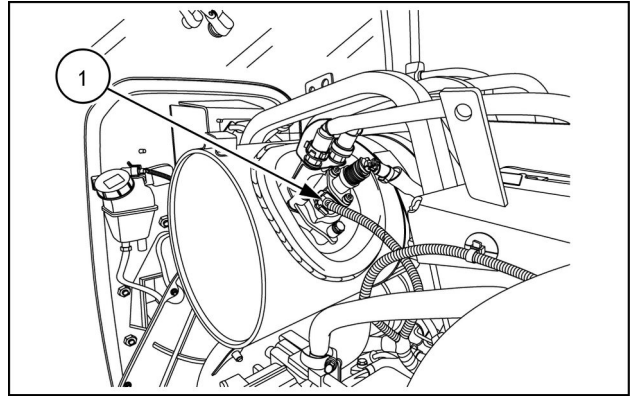

NHIL15TR00129AA 11

20. Disconnect the two coolant hoses (1) and the **DEF/ADBLUE®** line (2) from the **DEF/ADBLUE®** dosing module **B-008 (3)**.

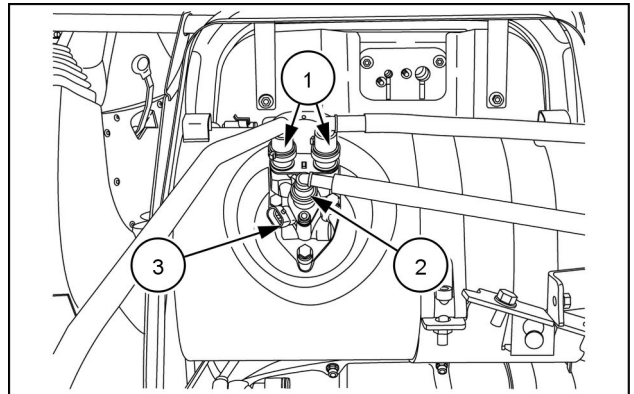

NHIL15TR00303AA 12

21. Disconnect the electrical connector **X-226 (1)** from the Air Conditioning (A/C) clutch compressor **Y-226 (2)**.

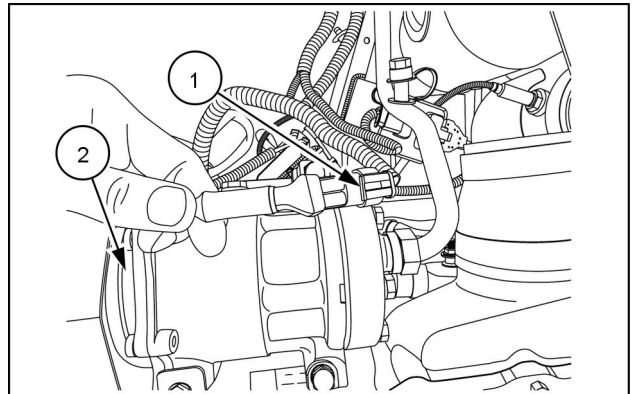

NHIL15TR00074AA 13

22. Disconnect the electrical connector **X-887 (3)** from the upstream Nitrogen Oxide (NOx) sensor signal amplifier **B-010**.

23. Cut and remove the cable ties (2) that secure the wiring harness (1).

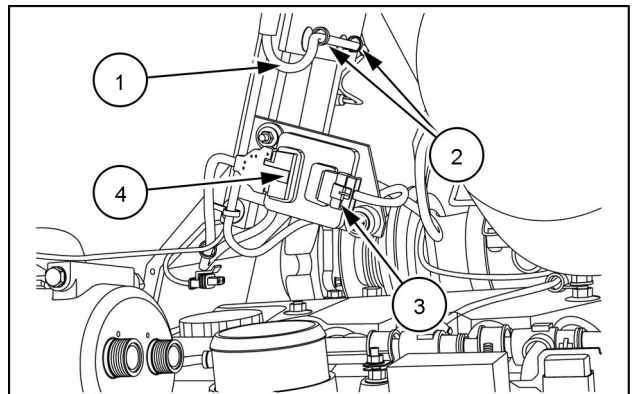

NHIL15TR00051AA 14

<https://www.ebooklibonline.com>

Hello dear friend!

Thank you very much for reading.

Enter the link into your browser.

The full manual is available for immediate download.

<https://www.ebooklibonline.com>