

FARMALL® 90C
FARMALL® 100C
FARMALL® 110C
FARMALL® 120C
Efficient Power
Tier 4B (final)
Tractor

SERVICE MANUAL

Part number 47878246

1st edition English

June 2015





SERVICE MANUAL

Farmall® 100C with cab, with Hi-Lo transmission , Farmall® 100C with cab, with mechanical or Power shuttle transmission , Farmall® 100C without cab, with Hi-Lo transmission , Farmall® 100C without cab, with mechanical or Power shuttle transmission , Farmall® 110C with cab, with Hi-Lo transmission , Farmall® 110C with cab, with mechanical or Power shuttle transmission , Farmall® 110C without cab, with Hi-Lo transmission , Farmall® 110C without cab, with mechanical or Power shuttle transmission , Farmall® 120C with cab, with Hi-Lo transmission , Farmall® 120C with cab, with mechanical or Power shuttle transmission , Farmall® 120C without cab, with Hi-Lo transmission , Farmall® 120C without cab, with mechanical or Power shuttle transmission , Farmall® 90C with cab, with Hi-Lo transmission , Farmall® 90C with cab, with mechanical or Power shuttle transmission , Farmall® 90C without cab, with Hi-Lo transmission , Farmall® 90C without cab, with mechanical or Power shuttle transmission

Link Product / Engine

Product	Market Product	Engine
Farmall® 100C without cab, with mechanical or Power shuttle transmission	North America	F5GFL413A*B007
Farmall® 100C with cab, with mechanical or Power shuttle transmission	North America	F5GFL413A*B007
Farmall® 100C without cab, with Hi-Lo transmission	North America	F5GFL413A*B006
Farmall® 100C with cab, with Hi-Lo transmission	North America	F5GFL413A*B006
Farmall® 110C without cab, with mechanical or Power shuttle transmission	North America	F5GFL413A*B007
Farmall® 110C with cab, with mechanical or Power shuttle transmission	North America	F5GFL413A*B007
Farmall® 110C without cab, with Hi-Lo transmission	North America	F5GFL413A*B006
Farmall® 110C with cab, with Hi-Lo transmission	North America	F5GFL413A*B006
Farmall® 120C without cab, with mechanical or Power shuttle transmission	North America	F5GFL413A*B007
Farmall® 120C with cab, with mechanical or Power shuttle transmission	North America	F5GFL413A*B007
Farmall® 120C without cab, with Hi-Lo transmission	North America	F5GFL413A*B006
Farmall® 120C with cab, with Hi-Lo transmission	North America	F5GFL413A*B006
Farmall® 90C without cab, with mechanical or Power shuttle transmission	North America	F5GFL413A*B007
Farmall® 90C with cab, with mechanical or Power shuttle transmission	North America	F5GFL413A*B007
Farmall® 90C without cab, with Hi-Lo transmission	North America	F5GFL413A*B006
Farmall® 90C with cab, with Hi-Lo transmission	North America	F5GFL413A*B006

<https://www.ebooklibonline.com>

Hello dear friend!

Thank you very much for reading.

Enter the link into your browser.

The full manual is available for immediate download.

<https://www.ebooklibonline.com>

Contents

INTRODUCTION

Engine	10
[10.001] Engine and crankcase	10.1
[10.216] Fuel tanks	10.2
[10.202] Air cleaners and lines	10.3
[10.254] Intake and exhaust manifolds and muffler	10.4
[10.500] Selective Catalytic Reduction (SCR) exhaust treatment.....	10.5
[10.400] Engine cooling system	10.6
[10.414] Fan and drive	10.7
[10.310] Aftercooler.....	10.8
Clutch	18
[18.100] Clutch mechanical release control	18.1
[18.104] Clutch hydraulic release control.....	18.2
[18.110] Clutch and components	18.3
Transmission	21
[21.130] Mechanical transmission external controls.....	21.1
[21.112] Power shuttle transmission.....	21.2
[21.110] Master clutch housing	21.3
[21.134] Power shuttle transmission external controls	21.4
[21.154] Power shuttle transmission internal components	21.5
[21.160] Creeper	21.6
[21.162] Reverser	21.7
[21.168] Hi-Lo unit.....	21.8
[21.109] Transmission cooler and lines.....	21.9
[21.118] Transmission/Rear drive	21.10
[21.148] Transmission/Rear drive internal components	21.11
[21.AAA] Transmission generic sub-group	21.12

Four-Wheel Drive (4WD) system	23
[23.101] Mechanical control	23.1
[23.202] Electro-hydraulic control	23.2
[23.314] Drive shaft	23.3
Front axle system	25
[25.100] Powered front axle	25.1
[25.102] Front bevel gear set and differential	25.2
[25.108] Final drive hub, steering knuckles, and shafts	25.3
[25.400] Non-powered front axle	25.4
Rear axle system	27
[27.106] Rear bevel gear set and differential	27.1
[27.120] Planetary and final drives	27.2
[27.100] Powered rear axle	27.3
Power Take-Off (PTO)	31
[31.101] Rear mechanical control	31.1
[31.104] Rear electro-hydraulic control	31.2
[31.110] One-speed rear Power Take-Off (PTO)	31.3
[31.114] Two-speed rear Power Take-Off (PTO)	31.4
Brakes and controls	33
[33.202] Hydraulic service brakes	33.1
[33.110] Parking brake or parking lock	33.2
[33.220] Trailer brake hydraulic control	33.3
Hydraulic systems	35
[35.104] Fixed displacement pump	35.1
[35.204] Remote control valves	35.2
[35.114] Three-point hitch control valve	35.3
[35.116] Three-point hitch cylinder	35.4

[35.160] Front hitch controls and lines	35.5
[35.701] Front loader arm hydraulic system	35.6
[35.723] Front loader bucket hydraulic system	35.7
Hitches, drawbars, and implement couplings.....	37
[37.100] Drawbars and towing hitches	37.1
[37.110] Rear three-point hitch	37.2
[37.120] Rear three-point hitch linkage.....	37.3
[37.162] Front hitch	37.4
[37.166] Front hitch linkage.....	37.5
Steering.....	41
[41.101] Steering control	41.1
[41.106] Tie rods.....	41.2
[41.200] Hydraulic control components.....	41.3
[41.206] Pump	41.4
[41.216] Cylinders	41.5
Wheels.....	44
[44.511] Front wheels.....	44.1
[44.520] Rear wheels	44.2
Cab climate control	50
[50.100] Heating	50.1
[50.104] Ventilation	50.2
[50.200] Air conditioning.....	50.3
Electrical systems	55
[55.100] Harnesses and connectors.....	55.1
[55.301] Alternator.....	55.2
[55.302] Battery.....	55.3
[55.014] Engine intake and exhaust system.....	55.4
[55.988] Selective Catalytic Reduction (SCR) electrical system	55.5

[55.640] Electronic modules	55.6
[55.518] Wiper and washer system.....	55.7
[55.404] External lighting	55.8
[55.408] Warning indicators, alarms, and instruments	55.9
[55.DTC] FAULT CODES.....	55.10
Front loader and bucket.....	82
[82.100] Arm.....	82.1
[82.300] Bucket.....	82.2
[82.AAA] Front loader and bucket generic sub-group	82.3
Platform, cab, bodywork, and decals	90
[90.150] Cab.....	90.1
[90.151] Cab interior.....	90.2
[90.160] Cab interior trim and panels.....	90.3
[90.154] Cab doors and hatches	90.4
[90.156] Cab glazing	90.5
[90.110] Operator platform less cab	90.6
[90.100] Engine hood and panels	90.7
[90.102] Engine shields, hood latches, and trims	90.8
[90.116] Fenders and guards.....	90.9



INTRODUCTION

Advice

IMPORTANT NOTICE

All maintenance and repair work described in this manual must be performed exclusively by CASE IH service technicians, in strict accordance with the instructions given and using any specific tools necessary.

Anyone performing the operations described herein without strictly following the instructions is personally responsible for any eventual injury or damage to property.

Note to the Owner WARNINGS FOR AIR CONDITIONING SYSTEM REPAIR OPERATIONS

Starting the system at low temperatures can damage the compressor. Only operate the air conditioner when the engine is hot and the temperature inside the cab is at least **20 °C (68.00 °F)**.

When disconnecting the hoses, close the ends with plastic caps to prevent foreign matter and humidity from getting inside the hoses.

Handle the thermostatic sensor carefully to avoid damage that may prevent efficient system operation.

Always use two spanners to unscrew the hose fittings to avoid twisting the fitting.

Do not use any type of engine oil to lubricate the compressor and the system.

Never leave the compressor oil container open, always make sure that it is tightly closed. If left exposed the oil will absorb humidity from the air and may, subsequently, damage the system.

Do not transfer compressor oil from the original container to another container.

Do not introduce any additives to the compressor oil. Any additional substances could contain elements which are incompatible with the chemical base of the refrigerant and thus alter its characteristics.

Check that the thermostatic sensor is correctly inserted in the fins on the evaporator to ensure efficient system operation.

Personal safety CAB AIR CONDITIONING SYSTEM

SAFETY REGULATIONS

- The refrigerant must be handled with great care in order to avoid personal injury; always use safety goggles and gloves.
- Liquid refrigerant can cause freezing of the skin and serious damage to the eyes, sometimes resulting in permanent blindness.
- Keep the refrigerant container away from heat sources. Heat will cause an increase in pressure of the refrigerant and could cause the container to explode.
- If refrigerant comes into contact with a naked flame or a hot metal surface it produces a toxic gas, which is dangerous if inhaled.
- In order to avoid accidents follow the simple precautions described below.
- The operation of emptying and charging the system must be carried out in a well-ventilated area, well away from any naked flames.
- During the charging and emptying operations, take the necessary precautions to protect the face and above all the eyes from accidental contact with refrigerant.
- In the event of an accident, proceed as follows:
 - if refrigerant splashes into the eyes, wash immediately with a few drops of mineral oil, then wash them thoroughly with a solution of boric acid and water (one spoonful of acid in 1/4 cup of water) and seek medical assistance immediately.
 - freezing of the skin caused by contact with liquid refrigerant may be treated by gradually warming the injured area with cold water, followed by the application of a greasy cream. Request medical assistance.
 - the air conditioning system contains a mixture of refrigerant and oil under high pressure; under no circumstances loosen pipe fittings/unions or work on the pipes without having first drained the system.
 - do not loosen or remove the compressor oil level check cap with the system pressurized.
 - do not heat the refrigerant container. If the temperature exceeds **50 °C (122.00 °F)** the pressure will increase very rapidly.
 - keep the air conditioning system away from heat sources to prevent explosions as a result of an increase in pressure in the system piping.
- When transferring refrigerant from one container to another, only use homologated liquid refrigerant containers equipped with safety valves.
- Never fill liquid refrigerant containers over **80 % (80.0 %)** of their maximum capacity.
- Do not modify the settings of safety valves and the control devices.
- Never connect the recovery/recycling and evacuation/charging stations to electrical power outlets with voltages other than those specified; do not leave the stations powered up unless they are to be used immediately.

Safety rules SAFETY REGULATIONS

TO PREVENT ACCIDENTS

Most accidents or injuries that occur in workshops are the result of non-observance of simple and fundamental safety regulations.

For this reason, IN MOST CASES THESE ACCIDENTS CAN BE AVOIDED: by foreseeing possible causes and consequently acting with the necessary caution and care.

Accidents may occur with all types of vehicle, regardless of how well it was designed and built.

A careful and judicious service technician is the best guarantee against accidents.

Precise observance of the most basic safety rule is normally sufficient to avoid many serious accidents.

DANGER: Never carry out any cleaning, lubrication or maintenance operations when the engine is running.

GENERAL

- Carefully follow specified repair and maintenance procedures.
- Do not wear rings, wristwatches, jewellery, unbuttoned or loose articles of clothing such as: ties, torn clothing, scarves, open jackets or shirts with open zips that may remain entangled in moving parts.
It is advised to wear approved safety clothing, e.g: non-slip footwear, gloves, safety goggles, helmets, etc.
- Do not carry out repair operations with someone sitting in the driver's seat, unless the person is a trained technician who is assisting with the operation in question.
- Operate the vehicle and use the implements exclusively from the driver's seat.
- Do not carry out operations on the vehicle with the engine running, unless specifically indicated.
- Stop the engine and ensure that all pressure is relieved from hydraulic circuits before removing caps, covers, valves, etc.
- All repair and maintenance operations must be carried out using extreme care and attention.
- Service steps and platforms used in a workshop or in the field should be built in compliance with the safety rules in force.
- Disconnect the batteries and label all controls to indicate that the vehicle is being serviced. Block the machine and all equipment which should be raised.
- Do not check or fill fuel tanks, accumulator batteries, nor use starting liquid when smoking or near naked flames, as these fluids are inflammable.
- Brakes are inoperative if manually released for repair or maintenance purposes.
In such cases, the machine should be kept constantly under control using blocks or similar devices.
- The fuel nozzle should always be in contact with the filling aperture. Maintain this position until filling operations are completed in order to avoid possible sparks caused by the accumulation of static electricity.
- Only use specified towing points for towing the tractor, connect parts carefully. Make sure that all pins and/or locks are secured in position before applying traction.
Never remain near the towing bars, cables or chains that are operating under load
- Transport vehicles that cannot be driven using a trailer or a low-loading platform trolley, if available.
- When loading or unloading the vehicle from the trailer (or other means of transport), select a flat area capable of sustaining the trailer or truck wheels, firmly secure the tractor to the truck or trailer and lock the wheels in the position.
- Electric heaters, battery-chargers and similar equipment must only be powered by auxiliary power supplies with efficient ground insulation to avoid electrical shock hazards.
- Always use suitable hoisting or lifting devices when raising or moving heavy parts.
- Take extra care if bystanders are present.
- Never pour gasoline or diesel oil into open, wide and low containers.
- Never use gasoline, diesel oil or other inflammable liquids as cleaning agents. Use non-flammable non-toxic proprietary solvents.
- Wear safety goggles with side guards when cleaning parts with compressed air.
- Limit the air pressure to a maximum of **2.1 bar (30.5 psi)**, according to local regulations.

- Do not run the engine in confined spaces without suitable ventilation.
- Do not smoke, use naked flames, or cause sparks in the area when fuel filling or handling highly inflammable liquids.
- Never use naked flames for lighting when working on the machine or checking for leaks.
- All movements must be carried out carefully when working under, on or near the vehicle and wear protective equipment: helmets, goggles and special footwear.
- When carrying out checks with the engine running, request the assistance of an operator in the driver's seat. The operator must maintain visual contact with the service technician at all times.
- If operating outside the workshop, position the vehicle on a flat surface and lock in position. If working on a slope, lock the vehicle in position and move to a flat area as soon as is safely possible.
- Damaged or bent chains or cables are unreliable. Do not use them for lifting or towing. Always use suitable protective gloves when handling chains or cables.
- Chains should always be safely secured. Ensure that fastening device is strong enough to hold the load foreseen. No persons should stop near the fastening point, trailing chains or cables.
- Maintenance and repair operations must be carried out in a CLEAN and DRY area, eliminate any water or oil spillage immediately.
- Do not create piles of oil or grease--soaked rags as they represent a serious fire hazard; store them in a closed metal container.
Before starting the vehicle or implements, make sure that the driver's seat is locked in position and always check that the area is free of persons or obstacles.
- Empty pockets of all objects that may fall unobserved into the vehicle parts when disassembled.
- In the presence of protruding metal parts, use protective goggles or goggles with side guards, helmets, special footwear and gloves.
- Handle all parts carefully, do not put your hands or fingers between moving parts, wear suitable safety clothing -- safety goggles, gloves and shoes.

WELDING OPERATIONS

- When welding, use protective safety devices: tinted safety goggles, helmets, special overalls, gloves and footwear. All persons present in the area where welding is taking place must wear tinted goggles. NEVER LOOK AT THE WELDING ARC IF YOUR EYES ARE NOT SUITABLY PROTECTED.
- Where possible, remove the part or tool that requires arc welding from the tractor.
- Disconnect both battery leads. Isolate the cable ends to avoid contact with each other and the tractor.
- Position the welder ground clamp as near as possible to the area where welding is taking place.
- Remove the electronic control units located on the tractor if welding is to be carried out near these control units.
- Never allow welding cables to lay on, near or across any electrical wiring or electronic component while welding is in progress.
- Metal cables tend to fray with repeated use. Always use suitable protective devices (gloves, goggles, etc.) when handling cables.

START UP

- Never start the engine in confined spaces that are not equipped with adequate ventilation for exhaust gas extraction.
- Never place the head, body, limbs, feet, hands or fingers near fans or rotating belts.

ENGINE

- Always loosen the radiator cap slowly before removing it to allow any remaining pressure in the system to be discharged. Coolant should be topped up only when the engine is stopped or idle if hot.
- Never fill up with fuel when the engine is running, especially if hot, in order to prevent the outbreak of fire as a result of fuel spillage
- Never check or adjust fan belt tension when the engine is running. Never adjust the fuel injection pump when the vehicle is moving.

- Never lubricate the vehicle when the engine is running.

ELECTRICAL SYSTEMS

- If it is necessary to use auxiliary batteries, remember that both ends of the cables must be connected as follows: (+) with (+) and (-) with (-).
- Avoid short-circuiting the terminals. GAS RELEASED FROM BATTERIES IS HIGHLY INFLAMMABLE.
- During charging, leave the battery compartment uncovered to improve ventilation.
- Never check the battery charge using "jumpers" (metal objects placed on the terminals).
- Avoid sparks or flames near the battery zone to prevent explosion hazards.
- Before servicing operations, check for fuel or current leaks. Eliminate any eventual leaks before starting work.
- Never charge batteries in confined spaces. Make sure that there is adequate ventilation in order to prevent accidental explosion hazards as a result of the accumulation of gases released during charging operations.
- Always disconnect the battery before performing any kind of servicing on the electrical system.

HYDRAULIC SYSTEMS

- Some fluid slowly coming out from a very small port can be almost invisible and be strong enough to penetrate the skin. Check for leaks using a piece of cardboard, NEVER USE HANDS.
- If any liquid penetrates skin tissue, call for medical aid immediately
- Serious skin infections may result if medical attention is not given.
- Use the specific tools when checking pressure values on the hydraulic system.

WHEELS AND TYRES

- Check that the tyres are correctly inflated at the pressure specified by the manufacturer. Periodically check possible damages to the rims and tyres.
- Stand away from (at the side of) the tire when checking inflation pressure.
- Only check pressure when the vehicle is unloaded and the tires are cold, to avoid incorrect readings as a result of over--pressure.
- Do not re--use parts of recovered wheels as incorrect welding or brazing may heat the material, causing it to weaken and eventually damage or break the wheel.
- Never cut, nor weld a rim with the inflated tyre assembled.
- When removing the wheels, lock both the front and rear vehicle wheels.
- Always position support stands when raising the vehicle, in order to conform to current safety regulations.
- Deflate the tyre before removing any object caught into the tyre tread.
- Never inflate tires using inflammable gases; this could cause an explosion and put operator safety at risk.

REMOVAL AND RE-FITTING

- Lift and handle all heavy parts using suitable lifting equipment and make sure that all slings and hooks are correctly secured.
- Handle all parts carefully during lifting operations, keep an eye on the personnel working near the load to be lifted. Never insert hands or fingers between parts, always wear approved accident prevention clothing (goggles, gloves and work boots).
- Avoid twisting chains or metal cables and always wear safety gloves when handling cables or chains.



SERVICE MANUAL

Engine

Farmall® 100C with cab, with Hi-Lo transmission , Farmall® 100C with cab, with mechanical or Power shuttle transmission , Farmall® 100C without cab, with Hi-Lo transmission , Farmall® 100C without cab, with mechanical or Power shuttle transmission , Farmall® 110C with cab, with Hi-Lo transmission , Farmall® 110C with cab, with mechanical or Power shuttle transmission , Farmall® 110C without cab, with Hi-Lo transmission , Farmall® 110C without cab, with mechanical or Power shuttle transmission , Farmall® 120C with cab, with Hi-Lo transmission , Farmall® 120C with cab, with mechanical or Power shuttle transmission , Farmall® 120C without cab, with Hi-Lo transmission , Farmall® 120C without cab, with mechanical or Power shuttle transmission , Farmall® 90C with cab, with Hi-Lo transmission , Farmall® 90C with cab, with mechanical or Power shuttle transmission , Farmall® 90C without cab, with Hi-Lo transmission , Farmall® 90C without cab, with mechanical or Power shuttle transmission

Engine - Remove

⚠ DANGER

Heavy objects!

Lift and handle all heavy components using lifting equipment with adequate capacity. Always support units or parts with suitable slings or hooks. Make sure the work area is clear of all bystanders. Failure to comply will result in death or serious injury.

D0076A

1. Remove the engine hood (1), as shown in **Hood - Remove (90.100)**.
2. Remove the tank, as described in **Fuel tank - Remove (10.216)**.
3. Loosen the retaining bolts (1). Remove the front wheel fenders (2) (if any). Do this on both sides.

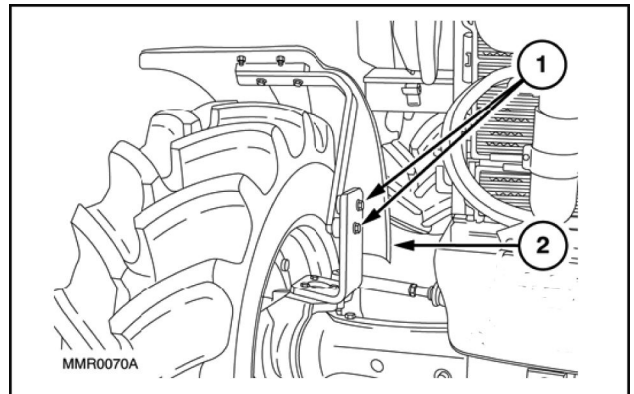

WLAPL4S10C104A 1

4. Refill the refrigerant of the climate control system through the fittings (1) and (2) using the dedicated recovery, emptying and refilling station. Detach the two lines by disconnecting any support straps.

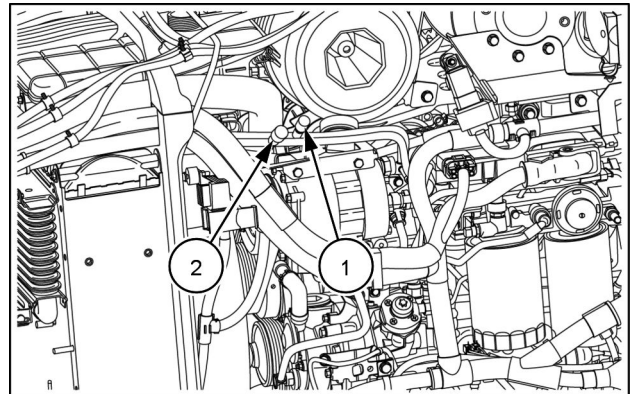

MOIL14TR00606AA 2

5. Then detach the lower pipe (3) on the condenser (1). Free the pipe from any straps or clamps. Disconnect the sensor (2). Place the pipe on the cab.

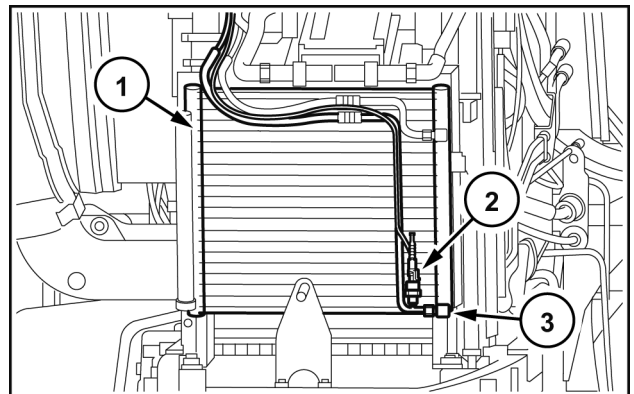

WLAPL4S10C107A 3

6. Raise the rear of the tractor with a hydraulic jack. Place a mechanical jack stand under the reduction gear case. Use a pneumatic gun to remove the retaining nuts of the left-hand rear wheel. Then remove the wheel.

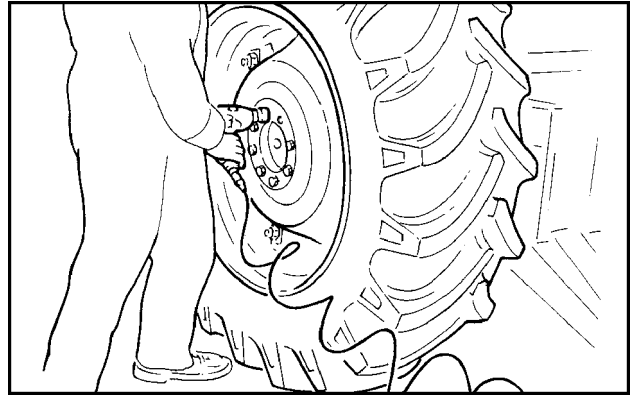

WLAPL4S10C110A 4

7. Unscrew the front, central, and rear retaining bolts on the guard of the front axle control shaft. Then remove the guard (1).

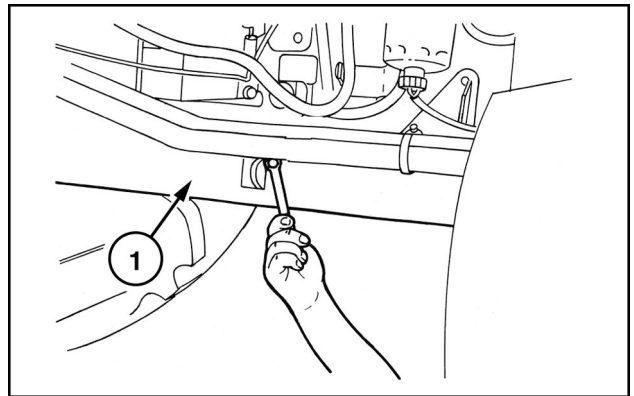

WLAPL4S10C112AA 5

8. Remove the circlip (2) and move the front sleeve (1) in the direction indicated by the arrow until it is released from the groove on the front axle.

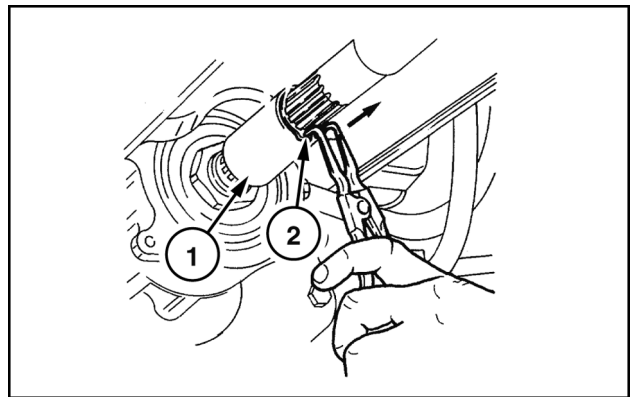

WLAPL4S10C113AA 6

9. Remove the bolts that secure the central support (1) of the drive shaft. Remove the shaft complete with the support. Also remove the shim that adjusts the clearance of the shaft on the back.

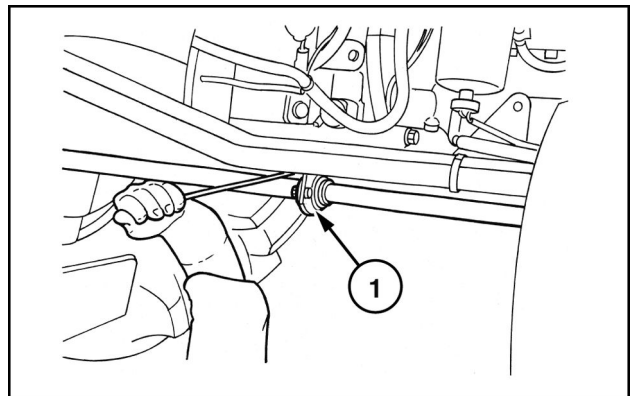

WLAPL4S10C115AA 7

10. Loosen the union of the radiator coolant return line of the cab heater. Drain and collect the engine coolant.

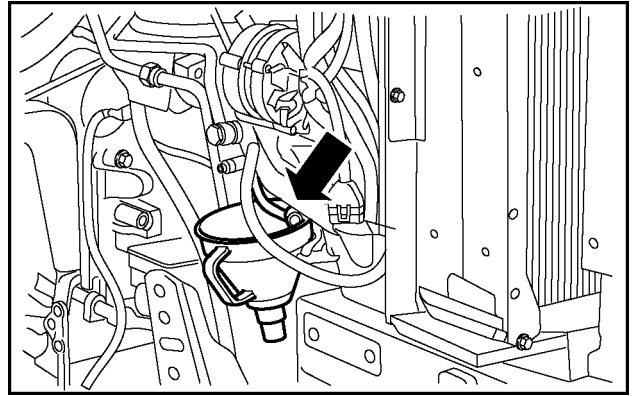

WLAPL4S10C116A 8

11. Place a suitable container under the drain plug (1) for the gearbox-transmission oil. Loosen the plug. Drain the oil.

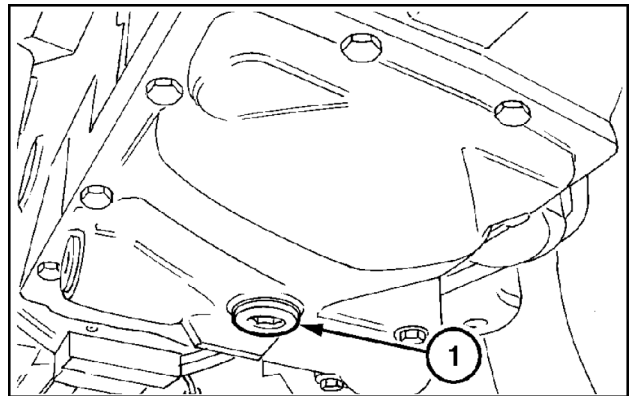

MOIL13TR00197AA 9

12. Loosen the fixing clamp (1) on the Diesel Oxidation Catalyst (DOC). Disconnect the drain tube (2). Remove the drain and remove the catalyst from the Selective Catalytic Reduction (SCR) system, as described in **Selective Catalytic Reduction (SCR) muffler and catalyst - Remove (10.500)**.

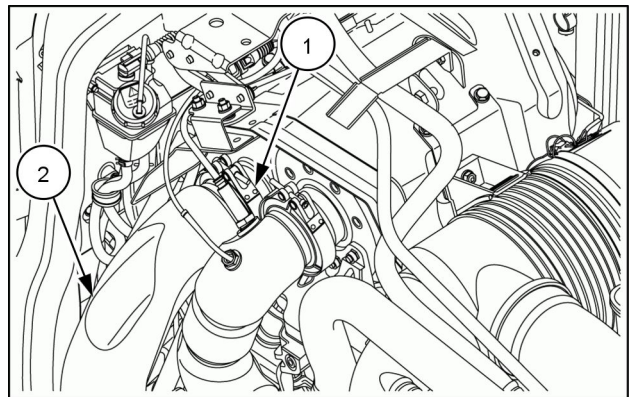

MOIL14TR00607AA 10

13. Loosen the fixing clamps (1). Extract the tubing from the turbine to the radiator intercooler (2). Perform the same operation for the tubing from the radiator intercooler to the engine (3).

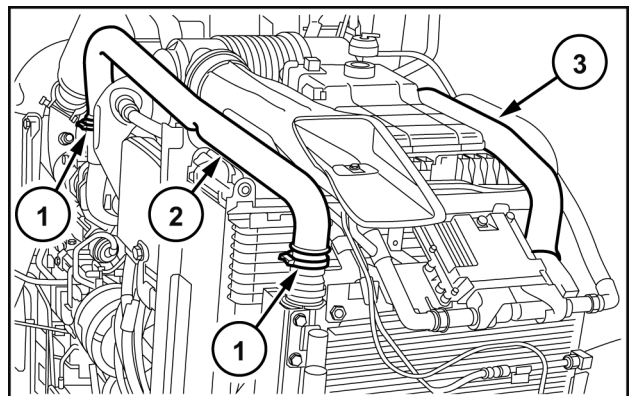

WLAPL4S10C119A 11

14. Loosen the clamp (2) that fastens the air intake duct to the turbine. Then free the air cleaner (4) together with the support bracket (3) from the screws that secure the air cleaner. Disconnect the oil vapor duct (1) on the right-hand side of the engine.

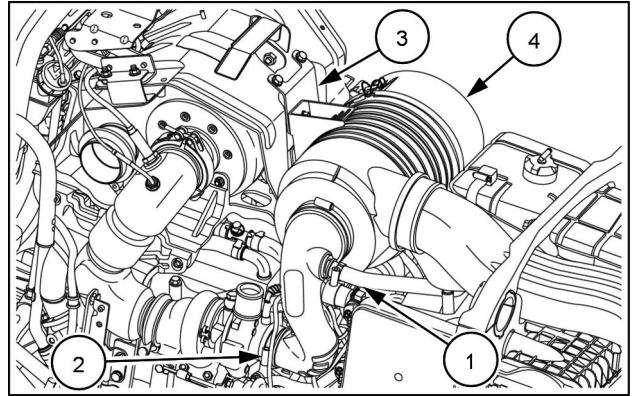

MOIL14TR00608AA 12

15. Disconnect the electrical connection (1) of the brake fluid tank. Disconnect the DOC sensor connections (2).

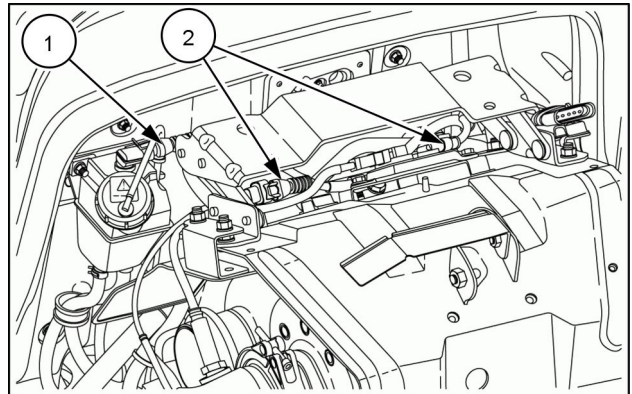

MOIL14TR00609AA 13

16. Remove the DEF/AdBlue® injector guard (1). Disconnect the electrical connections (3) and disconnect the lines (2) from the injector itself.

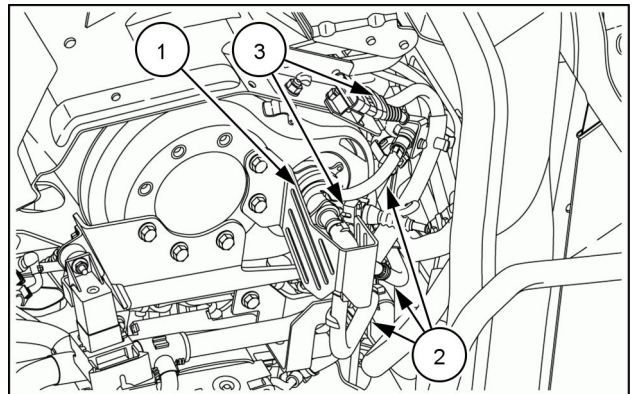

MOIL14TR00610AA 14

17. On the left-hand side of the vehicle, disconnect the lines (1) and (2) from the control valve for the coolant.

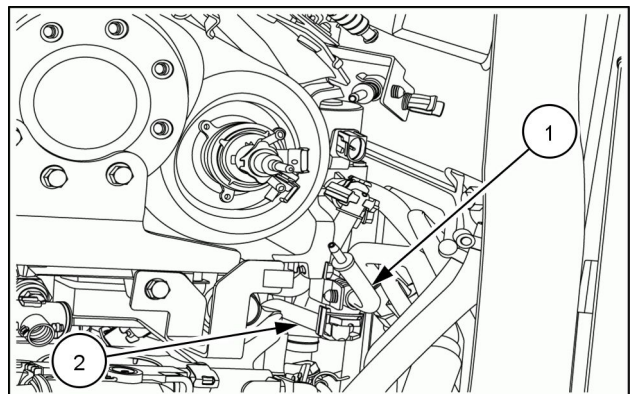

MOIL14TR00611AA 15

18. Disconnect the following lines: the steering lines **(1)** and **(2)**, the oil supply line **(4)** to the control valves, and the oil supply line **(3)** to the control valve for the power steering.

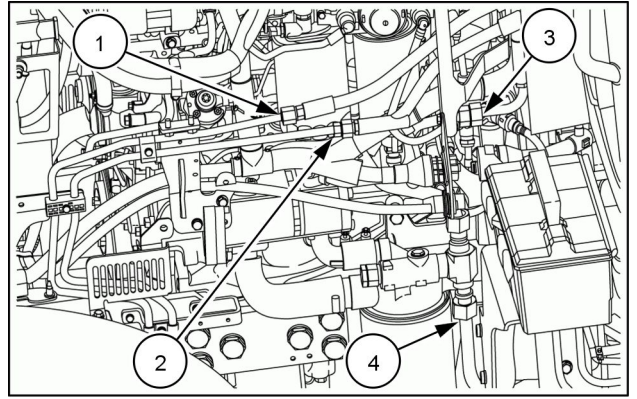

MOIL14TR00612AA 16

19. Disconnect the drain tube **(1)** of the control valve for the power steering.

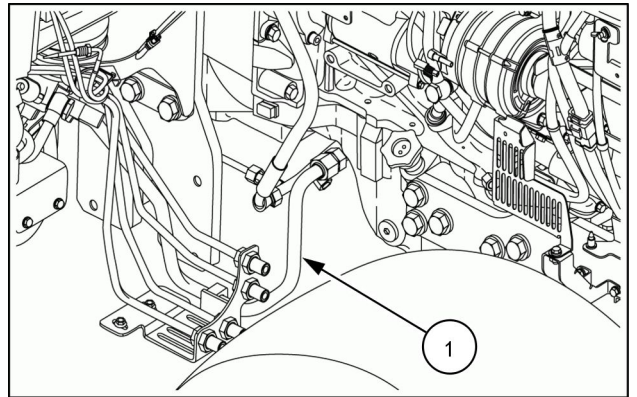

MOIL14TR00613AA 17

20. Detach the oil filter inlet pipe from the transmission **(1)**.

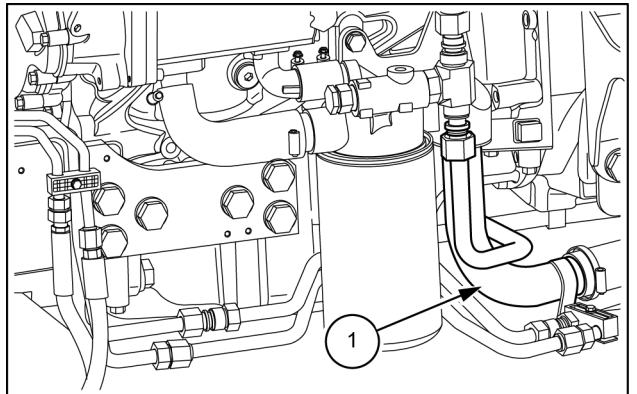

MOIL14TR00846AA 18

21. Detach the pipes **(2)** of the heat exchanger and, if applicable, of the front braking assembly **(1)**.
22. Free the lines that were previously detached from the supports, brackets, and clamps on the engine. Perform the same operation for the lines directed to the cylinder **(3)**.

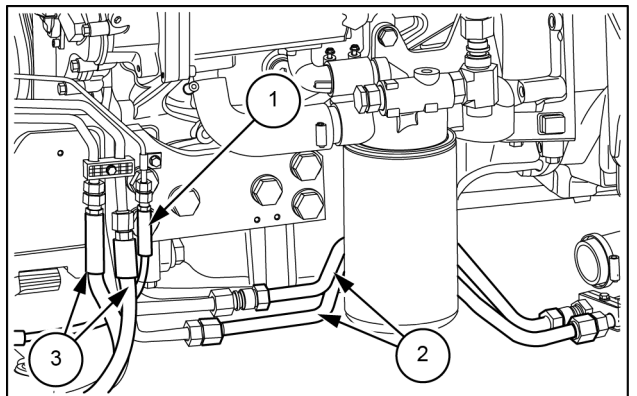

MOIL13TR01800AA 19

23. On the right-hand side, detach the cab heating pipes (1), the pipe inserted on the engine sleeve (2) coming from the expansion tank. Then loosen the clamps. Detach from the engine the lower (3) and upper rubber sleeves of the radiator-engine connection.

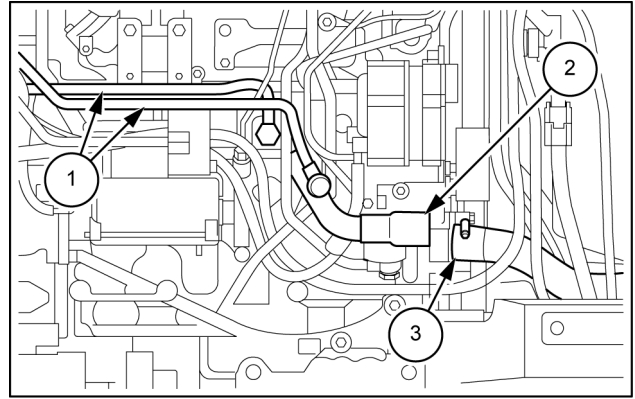

MOIL13TR01739AB 20

24. On the right-hand side, remove the shroud (1) on the starter motor (2). Disconnect the starting cable, the battery cut-off switch, and the cable that joins it to the alternator. Also disconnect the alternator and the battery positive. Free all of the wire harnesses detached from the various clamps.
25. Detach the mounting bolt (3). Then remove the ground cable of the engine and battery system. Remove the other mounting bolts of the motor and remove it.

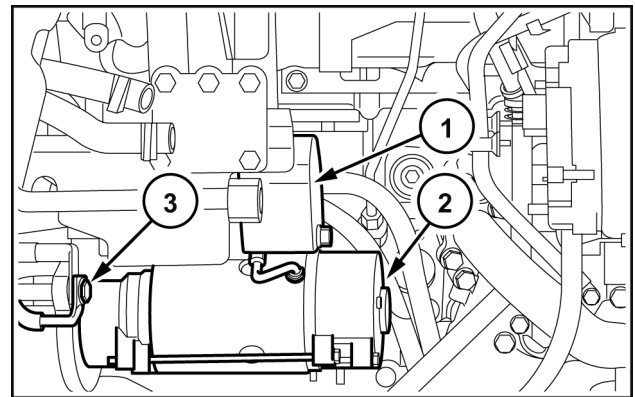

WLAPL4S10C135A 21

26. On the cable (1) of the FTP cable-engine interface, detach all of the connections (2). Leave only those connections on the maxi fuse case and on the glow plug controller. Then, after cutting the clamps, pick up the cable on the front, near the controller (5).
27. Starting from the connector on the controller (4), on the main engine cable (3) disconnect the connectors from the maxi fuse box and from the various switches and sensors located on the engine. After freeing the connector from the clamps, move the connector onto the back, at the height of the right-hand steps.

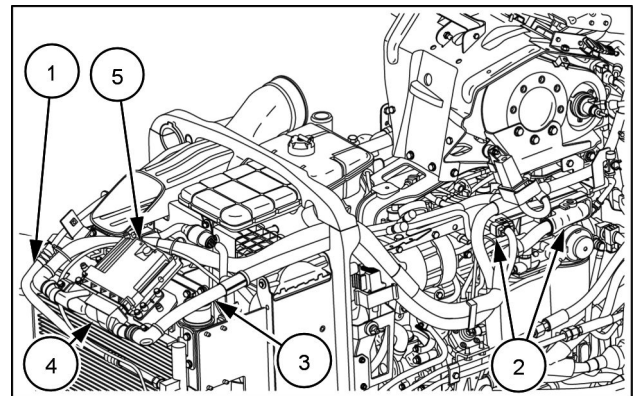

MOIL14TR00614AA 22

28. On the left-hand side, disconnect the connector of the power cable of the cab (1). Free the connector from the clamps. Move the connector onto the maxi fuse box.
29. Detach the bracket (2) supporting the cab connectors, cab power, and cup filter (3). Disconnect the pipe that joins the latter to the mechanical priming pump on the sediment filter.

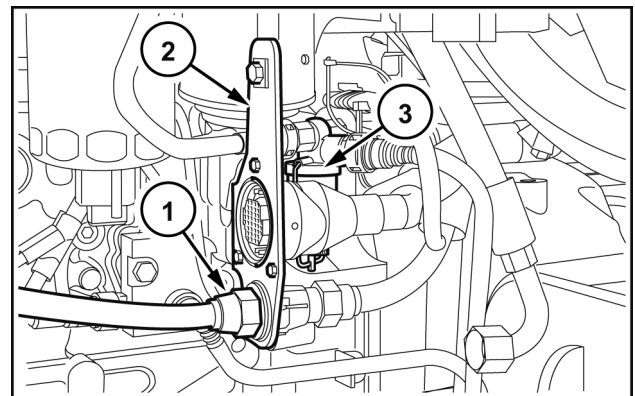

WLAPL4S10C139A 23

30. Hook the rear part of the engine to a hoist using chains or ropes for lifting. (Apply two eyebolts, one to the right-hand side and one to the left-hand side, on the upper part of the flange containing the flywheel.) Position a fixed jack stand (2) under the clutch case (1) near the engine attachment flanging. Apply the hand brake.

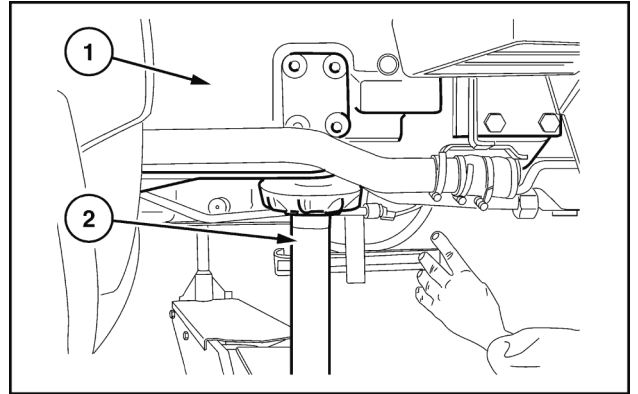

WLAPL4S10C129A 24

31. Position the movable tool for dismantling tractors (2) with the bracket and adapter plate under the engine. Place a wooden block (1) between the points of contact between the tool and the engine. Wedge the axle to prevent swinging.

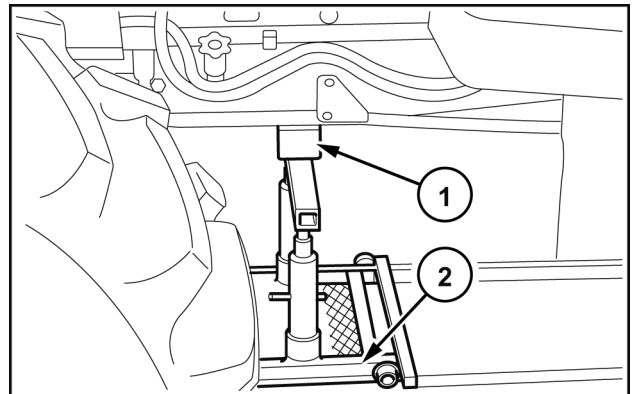

WLAPL4S10C140A 25

32. Remove the retaining bolts (1) between the engine and the transmission.

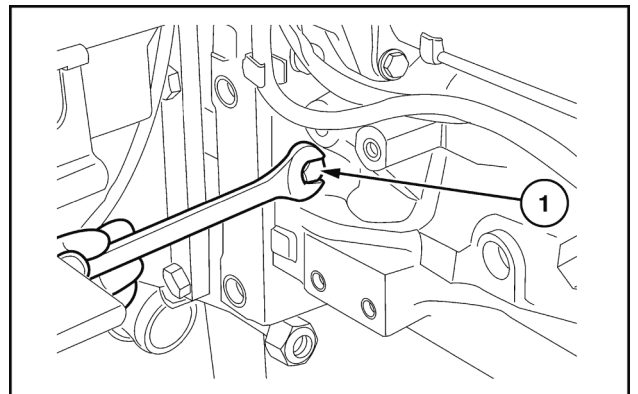

WLAPL4S10C130A 26

33. Separate the engine (1) from the transmission with the appropriate tool 380000405 (2).

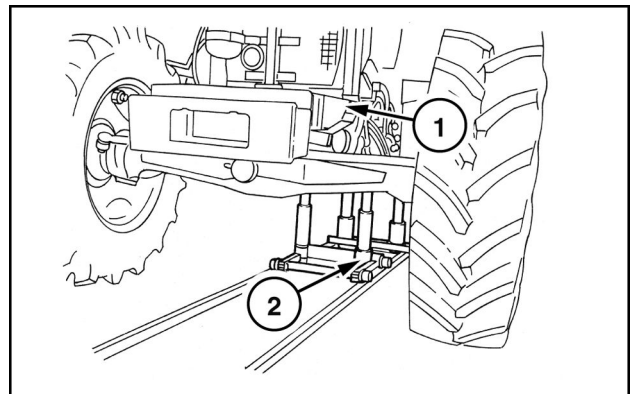

WLAPL4S10C131AA 27

34. Insert a fixed jack stand (1) under the ballast support. Chock the front wheels with wooden wedges (2).

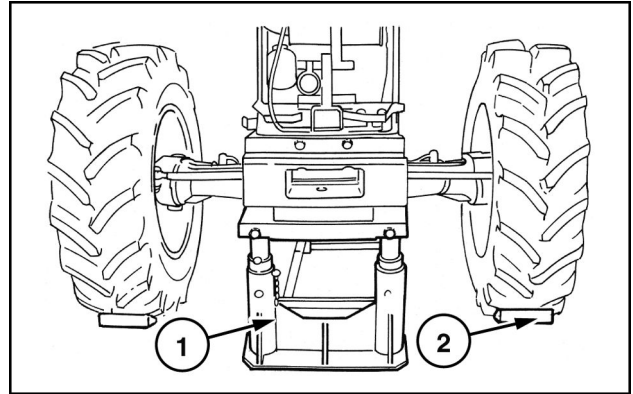

WLAPL4S10C132AA 28

35. Position a fixed jack stand (3) under the support of the groove (1) of the drive of the front axle, inserting a wooden plug (2) between parts (3) and (1).

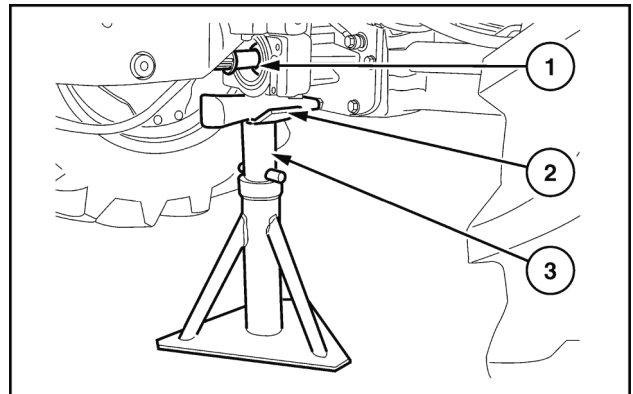

WLAPL4S10C133A 29

36. Set a stand under the back of the engine so as to be able to release the hoist with the coupling device in full safety. Add a rope or chain (1) also on the front of the engine. Take up the slack with the lifting device, keeping the engine balanced.

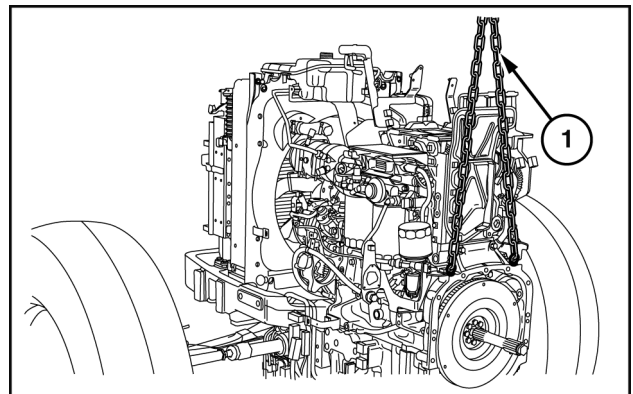

WLAPL4S10C136A 30

37. Remove the bolts (2) fastening the front axle support (1) to the engine.

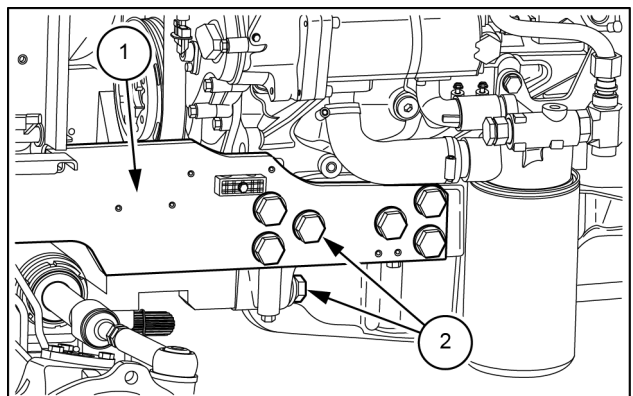

MOIL13TR01801AA 31

38. Check that there are no brackets between the engine and the cooling assembly. Detach the engine (2) from the front axle (3). Try to avoid incorrect maneuvers with the hoist in order to not damage the fins of the radiator on the axle with the engine fan (1). Rest the engine (2) on a support.

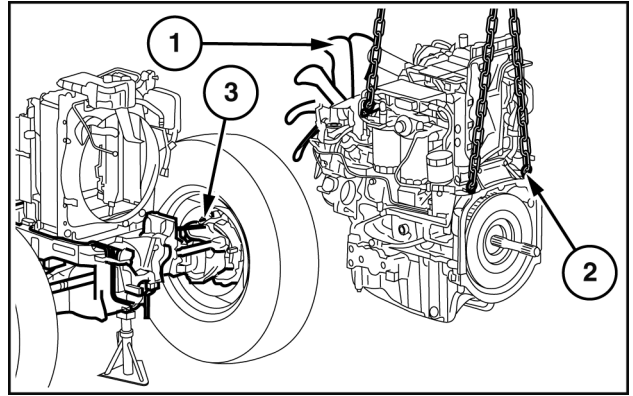

WLAPL4S10C138A 32

39. Remove the cooling fan (1).

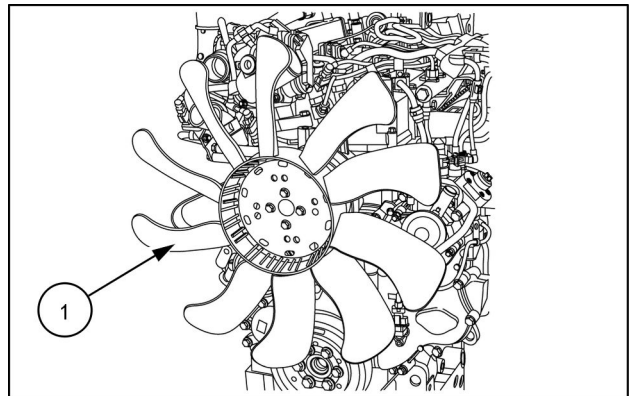

MOIL14UTL0038AA 33

40. Loosen the compressor fixing screws (4). Remove the belt (5). Then remove the compressor.
41. Completely loosen the belt tensioner (2). Remove the flexible belt (3). Then remove the alternator (1).

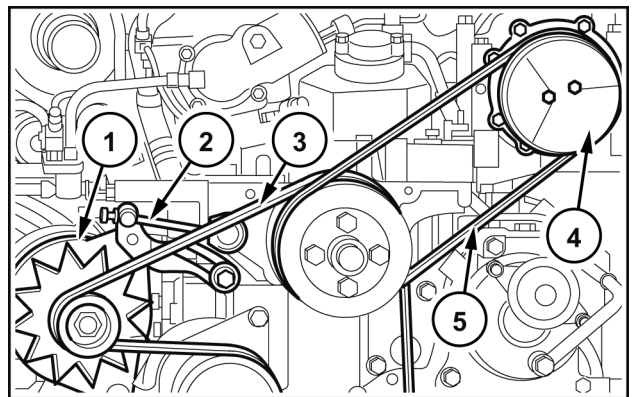

WLAPL4S10C145A 34

Engine - Remove

Farmall® 110C with cab, with Hi-Lo transmission	
Farmall® 110C with cab, with mechanical or Power shuttle transmission	
Farmall® 110C without cab, with Hi-Lo transmission	
Farmall® 110C without cab, with mechanical or Power shuttle transmission	
Farmall® 120C with cab, with Hi-Lo transmission	
Farmall® 120C with cab, with mechanical or Power shuttle transmission	
Farmall® 120C without cab, with Hi-Lo transmission	
Farmall® 120C without cab, with mechanical or Power shuttle transmission	
Farmall® 90C with cab, with Hi-Lo transmission	
Farmall® 90C with cab, with mechanical or Power shuttle transmission	
Farmall® 90C without cab, with Hi-Lo transmission	
Farmall® 90C without cab, with mechanical or Power shuttle transmission	

⚠ DANGER

Heavy objects!

Lift and handle all heavy components using lifting equipment with adequate capacity. Always support units or parts with suitable slings or hooks. Make sure the work area is clear of all bystanders. Failure to comply will result in death or serious injury.

D0076A

1. Remove the engine hood (1), as shown in **Hood - Remove (90.100)**.
2. Remove the tank, as described in **Fuel tank - Remove (10.216)**.
3. Loosen the retaining bolts (1). Remove the front wheel fenders (2) (if any). Do this on both sides.

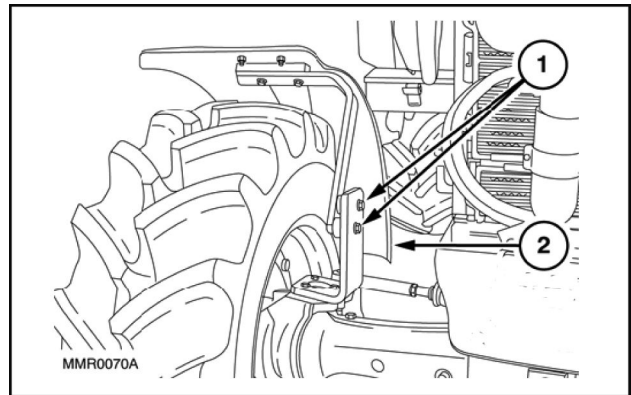

WLAPL4S10C104A 1

4. Refill the refrigerant of the climate control system through the fittings (1) and (2) using the dedicated recovery, emptying and refilling station. Detach the two lines by disconnecting any support straps.

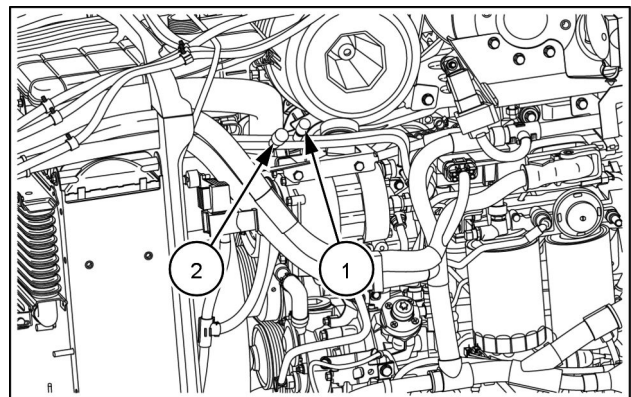

MOIL14TR00606AA 2

5. Then detach the lower pipe **(3)** on the condenser **(1)**. Free the pipe from any straps or clamps. Disconnect the sensor **(2)**. Place the pipe on the cab.

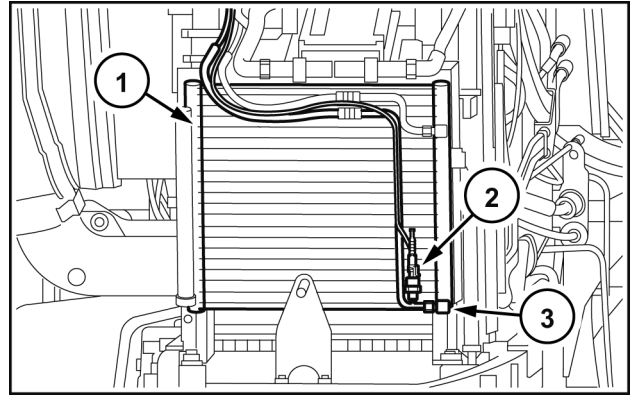

WLAPL4S10C107A 3

6. Raise the rear of the tractor with a hydraulic jack. Place a mechanical jack stand under the reduction gear case. Use a pneumatic gun to remove the retaining nuts of the left-hand rear wheel. Then remove the wheel.

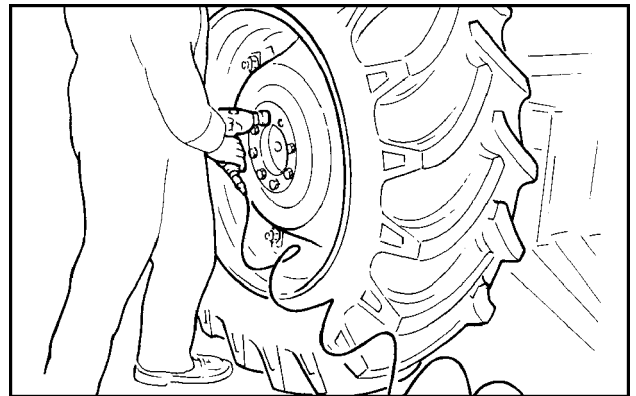

WLAPL4S10C110A 4

7. Unscrew the front, central, and rear retaining bolts on the guard of the front axle control shaft. Then remove the guard **(1)**.

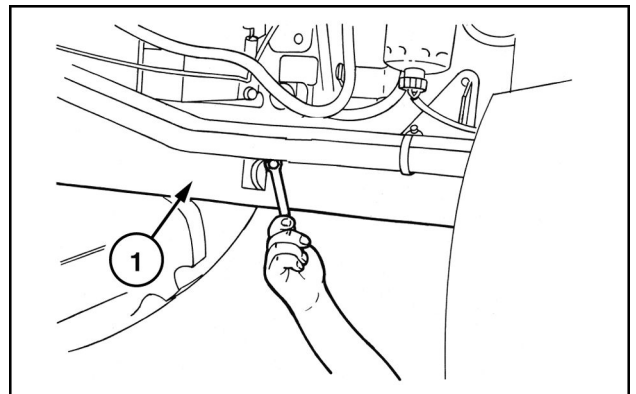

WLAPL4S10C112AA 5

8. Remove the circlip **(2)** and move the front sleeve **(1)** in the direction indicated by the arrow until it is released from the groove on the front axle.

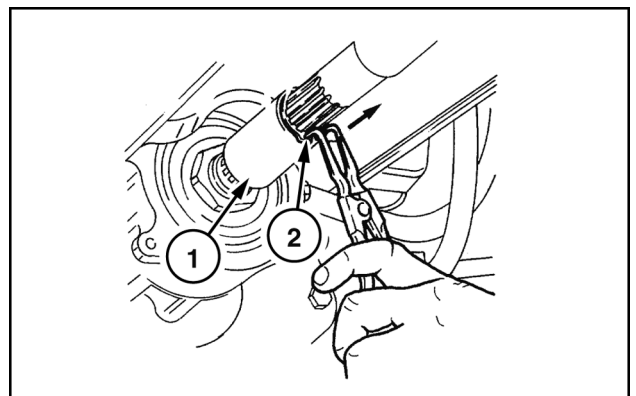

WLAPL4S10C113AA 6

9. Remove the bolts that secure the central support **(1)** of the drive shaft. Remove the shaft complete with the support. Also remove the shim that adjusts the clearance of the shaft on the back.

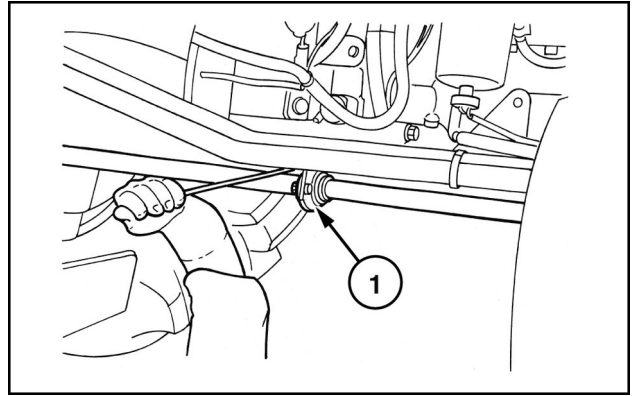

WLAPL4S10C115AA 7

10. Loosen the union of the radiator coolant return line of the cab heater. Drain and collect the engine coolant.

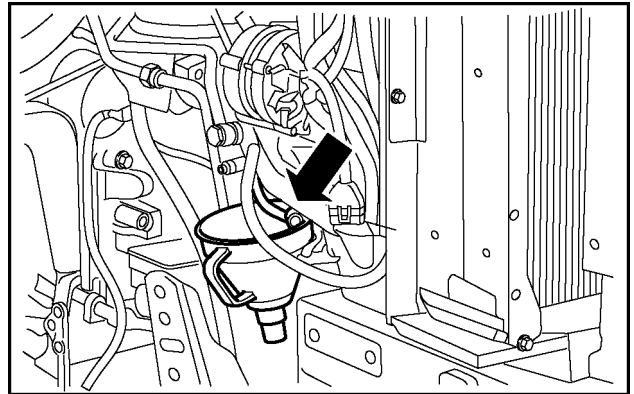

WLAPL4S10C116A 8

11. Place a suitable container under the drain plug **(1)** for the gearbox-transmission oil. Loosen the plug. Drain the oil.

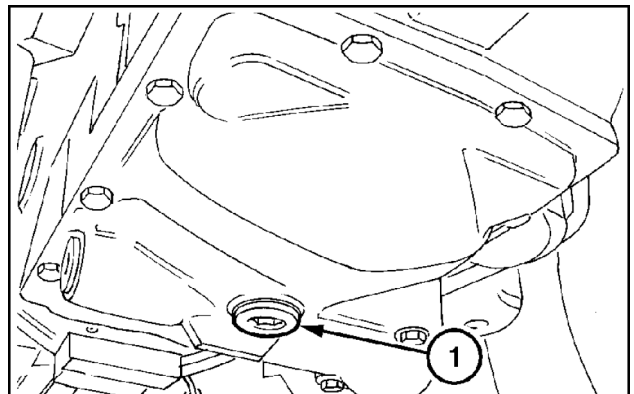

MOIL13TR00197AA 9

12. Loosen the fixing clamp **(1)** on the Diesel Oxidation Catalyst (DOC). Disconnect the drain tube **(2)**. Remove the drain and remove the catalyst from the Selective Catalytic Reduction (SCR) system, as described in **Selective Catalytic Reduction (SCR) muffler and catalyst - Remove (10.500)**.

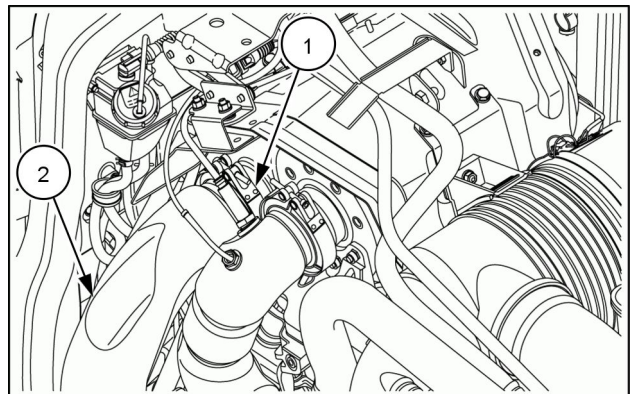

MOIL14TR00607AA 10

13. Loosen the fixing clamps **(1)**. Extract the tubing from the turbine to the radiator intercooler **(2)**. Perform the same operation for the tubing from the radiator intercooler to the engine **(3)**.

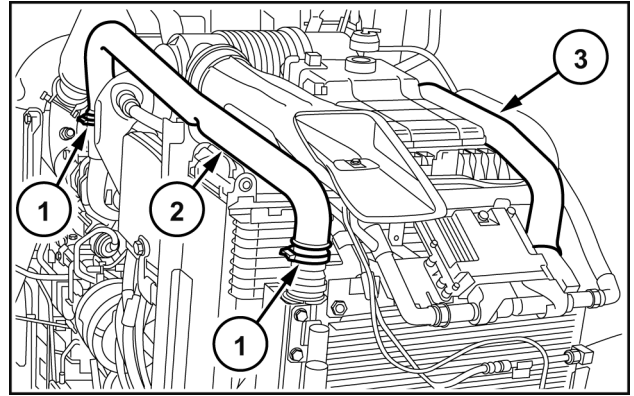

WLAPL4S10C119A 11

14. Loosen the clamp **(2)** that fastens the air intake duct to the turbine. Then free the air cleaner **(4)** together with the support bracket **(3)** from the screws that secure it. Disconnect the oil vapor duct **(1)** on the right-hand side of the engine.

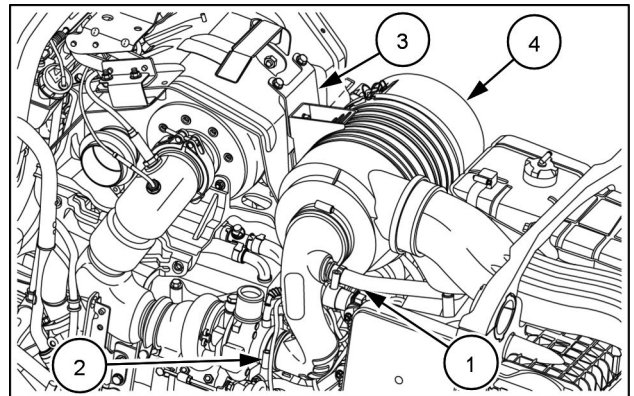

MOIL14TR00608AA 12

15. Disconnect the electrical connection **(1)** of the brake fluid tank. Disconnect the DOC sensor connections **(2)**.

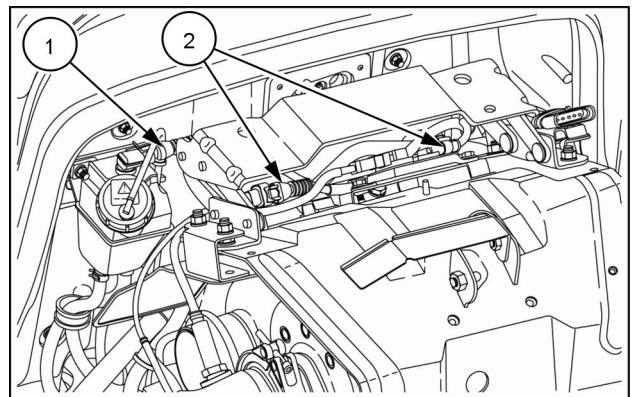

MOIL14TR00609AA 13

16. Remove the **DEF/AdBlue®** injector guard **(1)**. Disconnect the electrical connections **(3)** and disconnect the lines **(2)** from the injector itself.

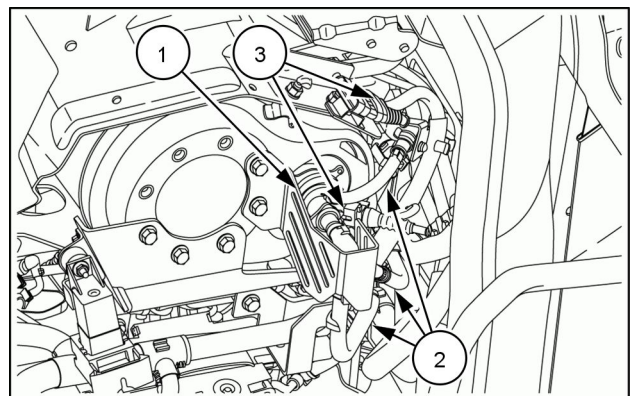

MOIL14TR00610AA 14

17. On the left-hand side of the vehicle, disconnect the lines **(1)** and **(2)** from the control valve for the coolant.

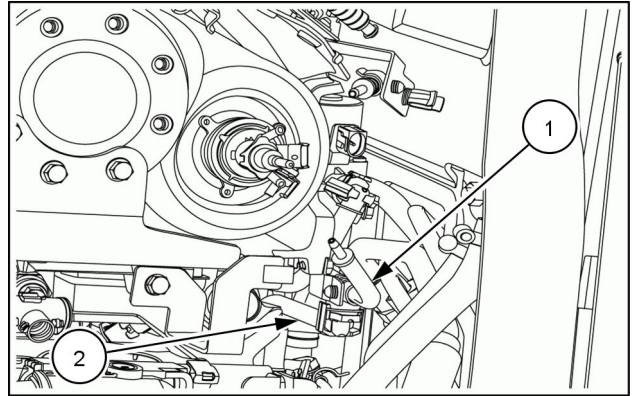

MOIL14TR00611AA 15

18. Disconnect the following lines: the steering lines **(1)** and **(2)**, the oil supply line **(4)** to the control valves, and the oil supply line **(3)** to the control valve for the power steering.

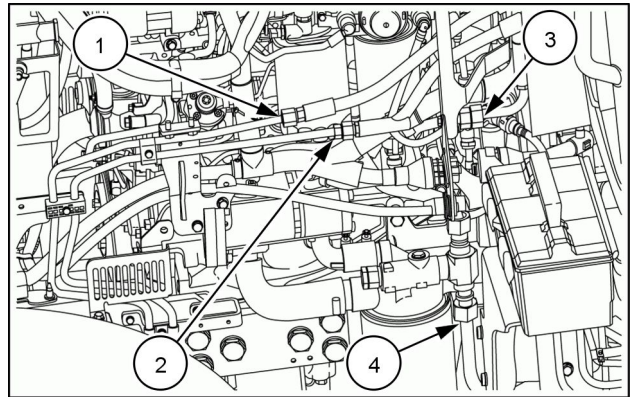

MOIL14TR00612AA 16

19. Disconnect the drain tube **(1)** of the control valve for the power steering.

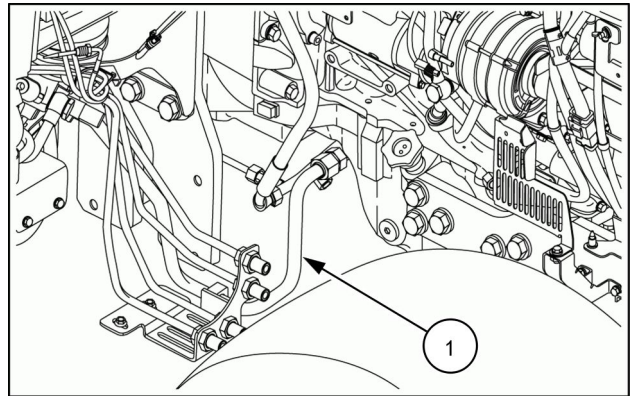

MOIL14TR00613AA 17

20. Detach the oil filter inlet pipe from the transmission **(1)**.

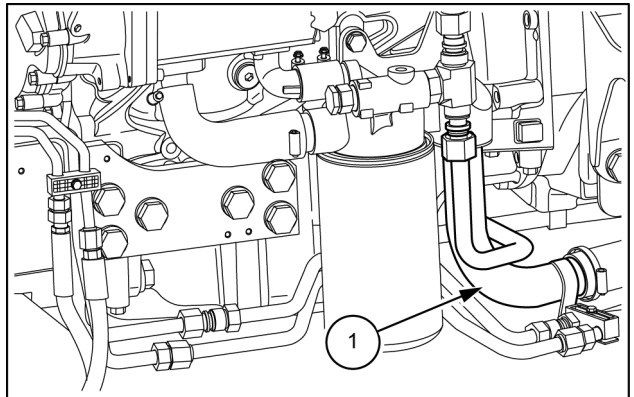

MOIL14TR00846AA 18

21. Detach the pipes **(2)** of the heat exchanger and, if applicable, of the front braking assembly **(1)**.
22. Free the lines that were previously detached from the supports, brackets, and clamps on the engine. Perform the same operation for the lines directed to the cylinder **(3)**.

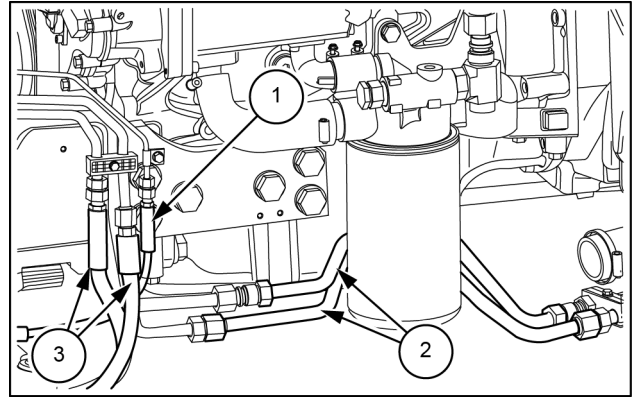

MOIL13TR01800AA 19

23. On the right-hand side, detach the cab heating pipes **(1)**, the pipe inserted on the engine sleeve **(2)** coming from the expansion tank. Then loosen the clamps. Detach from the engine the lower **(3)** and upper rubber sleeves of the radiator–engine connection.

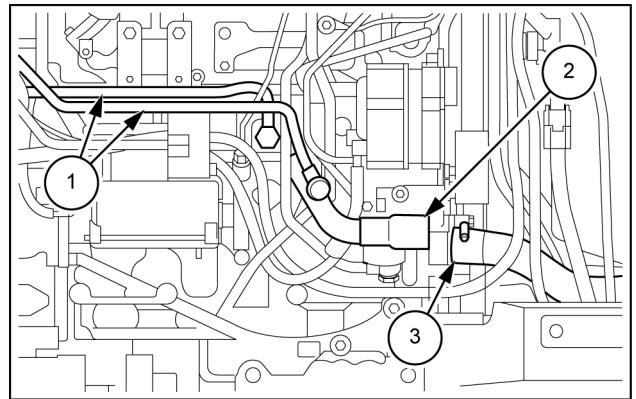

MOIL13TR01739AB 20

24. On the right-hand side, remove the shroud **(1)** on the starter motor **(2)**. Disconnect the starting cable, the battery cut-off switch, and the cable that joins it to the alternator. Also disconnect the alternator and the battery positive. Free all of the wire harnesses detached from the various clamps.
25. Detach the mounting bolt **(3)**. Then remove the ground cable of the engine and battery system. Remove the other mounting bolts of the motor and remove it.

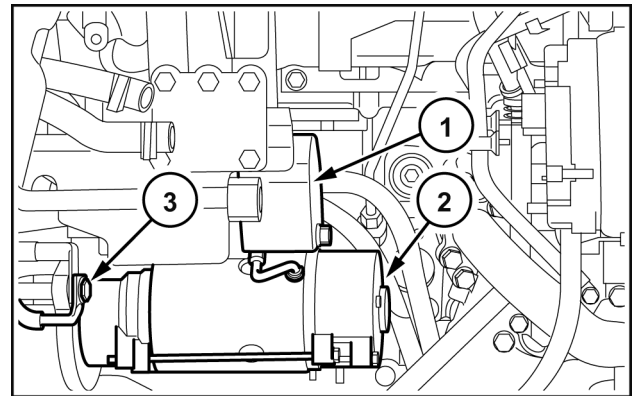

WLAPL4S10C135A 21

26. On the cable **(1)** of the FTP cable–engine interface, detach all of the connections **(2)**. Leave only those connections on the maxi fuse case and on the glow plug controller. Then, after cutting the clamps, pick up the cable on the front, near the controller **(5)**.
27. Starting from the connector on the controller **(4)**, on the main engine cable **(3)** disconnect the connectors from the maxi fuse box and from the various switches and sensors located on the engine. After freeing the connector from the clamps, move the connector onto the back, at the height of the right-hand steps.

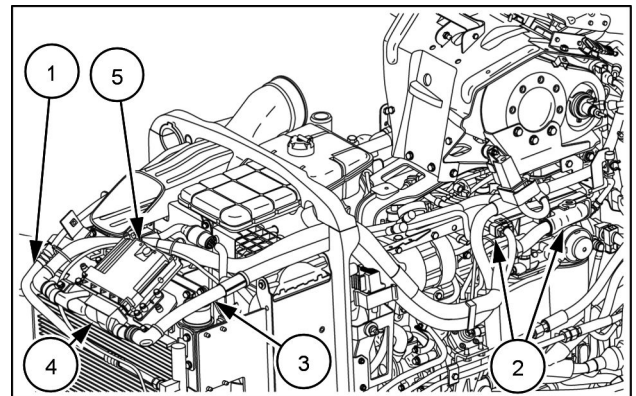

MOIL14TR00614AA 22

28. On the left-hand side, disconnect the connector of the power cable of the cab (1). Free the connector from the clamps. Move the connector onto the maxi fuse box.
29. Detach the bracket (2) supporting the cab connectors, cab power, and cup filter (3). Disconnect the pipe that joins the latter to the mechanical priming pump on the sediment filter.

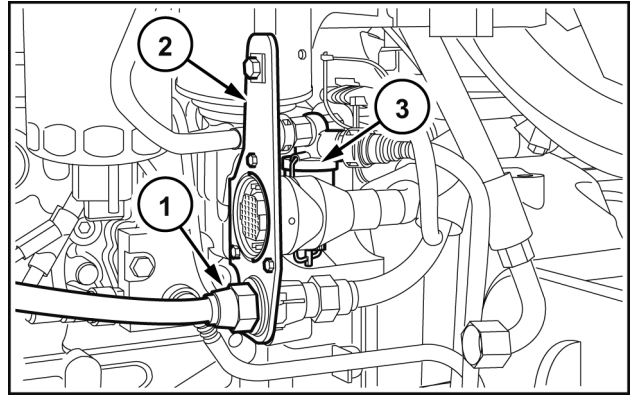

WLAPL4S10C139A 23

30. Hook the rear part of the engine to a hoist using chains or ropes for lifting. (Apply two eyebolts, one to the right-hand side and one to the left-hand side, on the upper part of the flange containing the flywheel.) Position a fixed jack stand (2) under the clutch case (1) near the engine attachment flanging. Apply the hand brake.

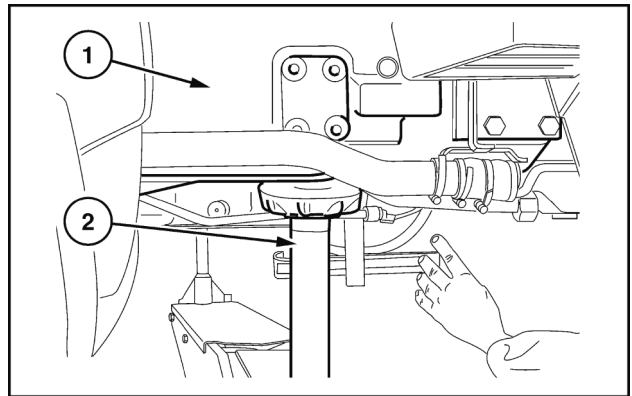

WLAPL4S10C129A 24

31. Position the movable tool for dismantling tractors (2) 380000405 with the bracket and adapter plate under the engine. Place a wooden block (1) between the points of contact between the tool and the engine. Wedge the axle to prevent swinging.

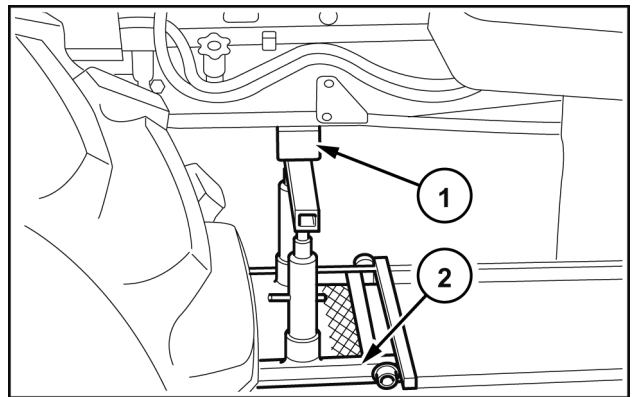

WLAPL4S10C140A 25

32. Remove the retaining bolts (1) between the engine and the transmission.

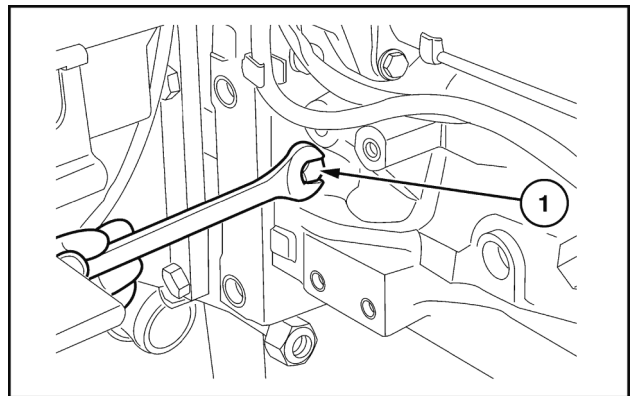

WLAPL4S10C130A 26

33. Separate the engine (1) from the transmission with the appropriate tool 380000405 (2).

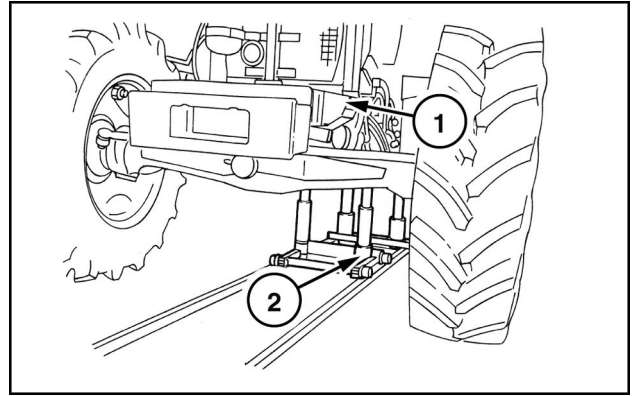

WLAPL4S10C131AA 27

34. Insert a fixed jack stand (1) under the ballast support. Chock the front wheels with wooden wedges (2).

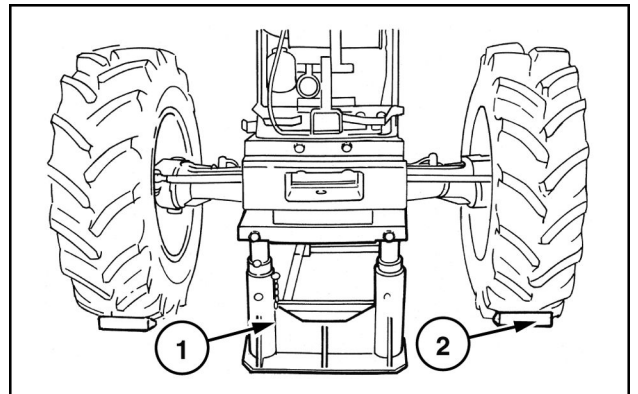

WLAPL4S10C132AA 28

35. Position a fixed jack stand (3) under the support of the groove (1) of the drive of the front axle, inserting a wooden plug (2) between parts (3) and (1).

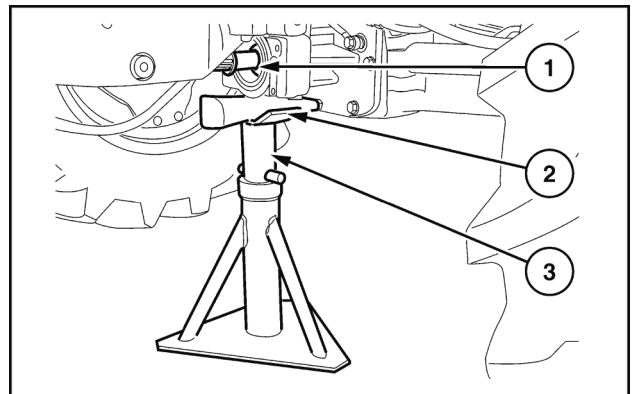

WLAPL4S10C133A 29

36. Set a stand under the back of the engine so as to be able to release the hoist with the coupling device in full safety. Add a rope or chain (1) also on the front of the engine. Take up the slack with the lifting device, keeping the engine balanced.

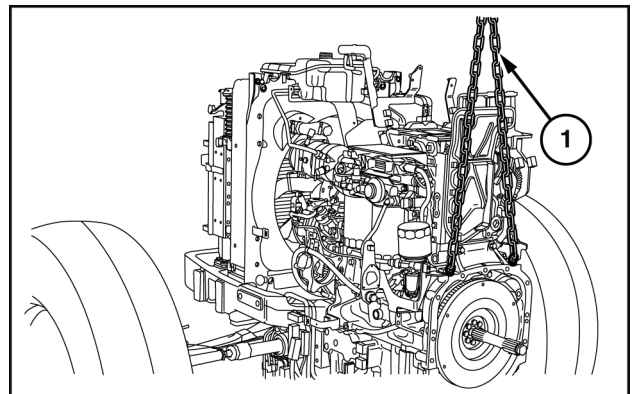

WLAPL4S10C136A 30

37. Remove the bolts (2) fastening the front axle support (1) to the engine.

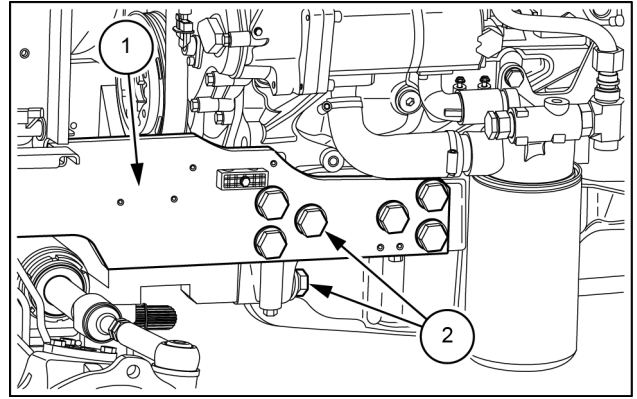

MOIL13TR01801AA 31

38. Check that there are no brackets between the engine and the cooling assembly. Detach the engine (2) from the front axle (3). Try to avoid incorrect maneuvers with the hoist in order to not damage the fins of the radiator on the axle with the engine fan (1). Rest the engine (2) on a support.

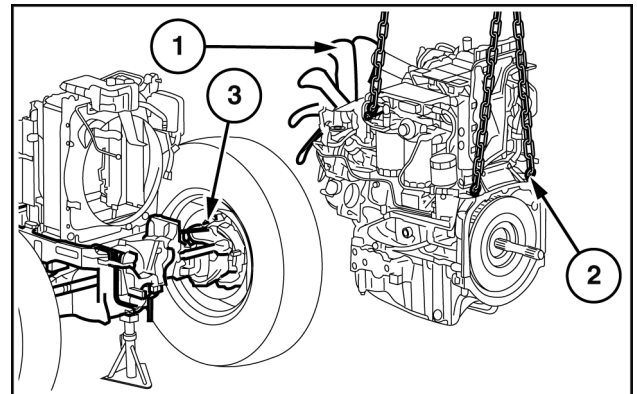

WLAPL4S10C138A 32

39. Remove the viscous coupling (1), if applicable, together with the fan (2).

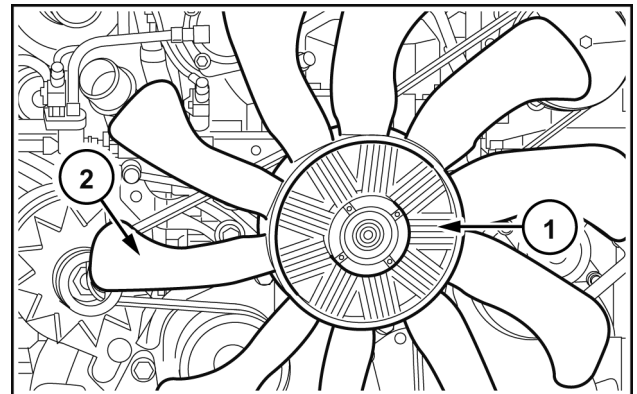

WLAPL4S10C144A 33

40. Loosen the compressor fixing screws (4). Remove the belt (5). Then remove the compressor.

41. Completely loosen the belt tensioner (2). Remove the flexible belt (3). Then remove the alternator (1).

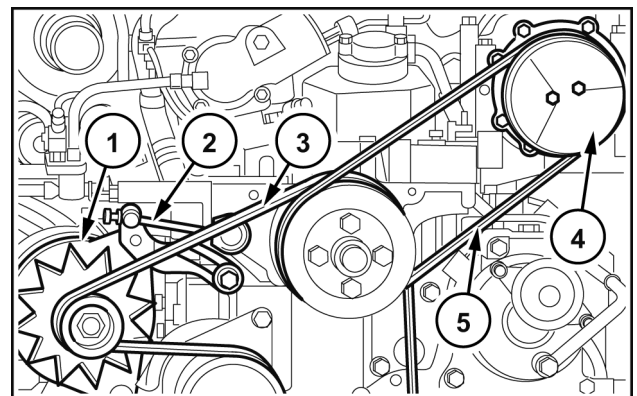

WLAPL4S10C145A 34

Engine - Install

⚠ DANGER

Heavy objects!

Lift and handle all heavy components using lifting equipment with adequate capacity. Always support units or parts with suitable slings or hooks. Make sure the work area is clear of all bystanders. Failure to comply will result in death or serious injury.

D0076A

1. Refit the flexible belt on the alternator and take up the slack according to the procedure in **Alternator - Tension adjust (55.301)**.
2. Reposition the compressor and the relevant belt following this procedure:
 - Reposition the compressor on the support and with the related tube support. Secure the compressor with the screws.
 - To mount the polyv belt, use the special tool **380200011**.
 - (1) approximately. Compressor clutch actuator drive bracket.
 - (2) approximately. polyv belt pulley outer edge.
 - (3) approximately. Tool recess. Used to drive the tool. This recess houses the bracket (1).
 - (4) approximately. Tail. Used to drive the polyv belt in the pulley seat.
 - (5) approximately. Hitching. Thanks to this recess, where the outer edge (2) is housed, the tool remains hitched to the compressor.

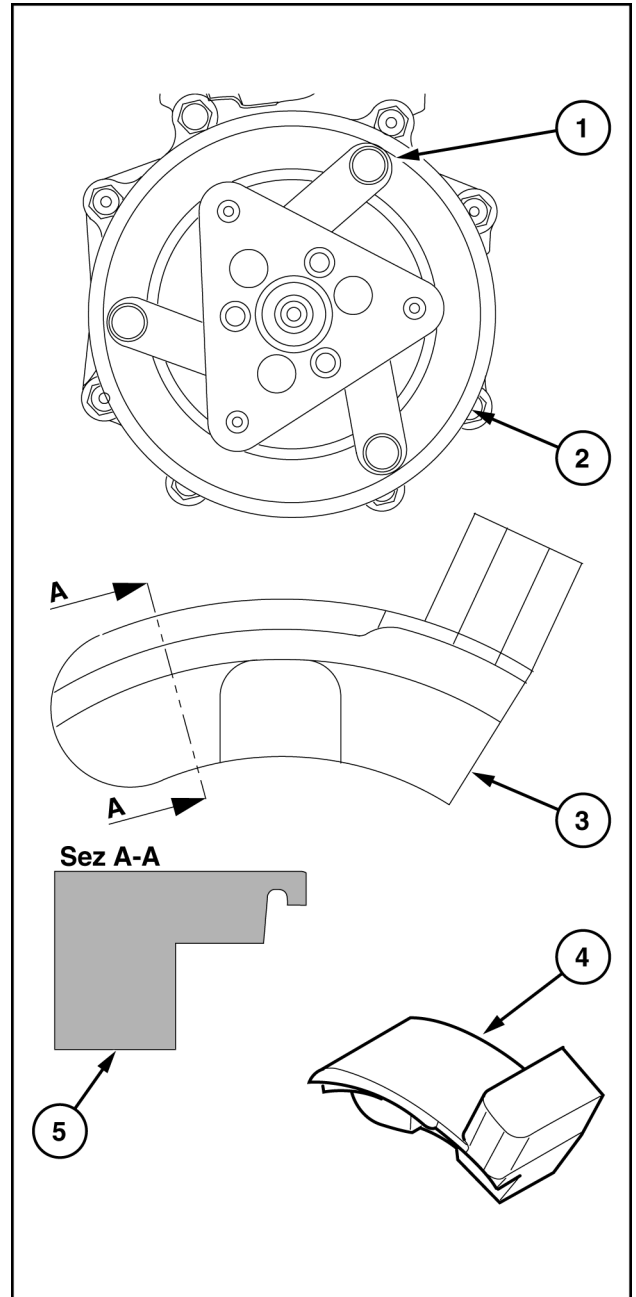

WLAPL4S10C101C 1



Suggest:

If the above button click is invalid.

Please download this document

first, and then click the above link

to download the complete manual.

Thank you so much for reading

3. Remove the three bolts (1) and the related dust cover for the compressor clutch.

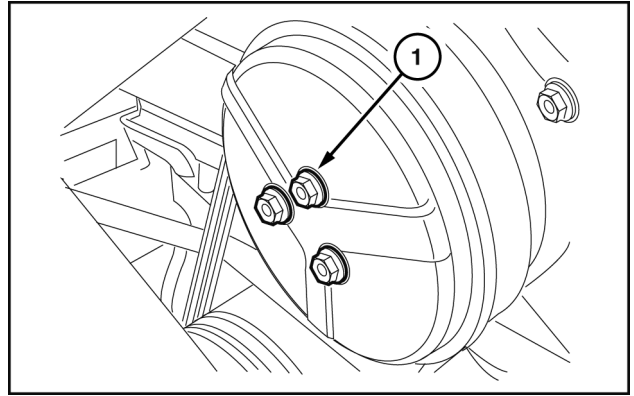

WLAPL4S10C142A 2

4. Ensure that the polyv belt (2) is perfectly housed on the fan pulley.
5. Move the belt (2) near to the compressor pulley. Keep the tool (1) 380200011 under the belt. Hook the tool onto the compressor clutch at the innermost part in order to slightly force the belt.

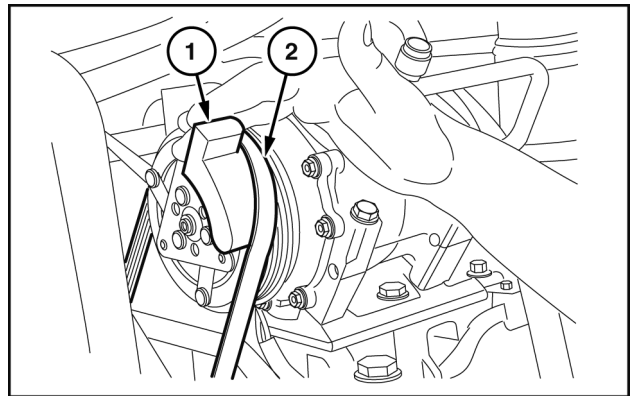

WLAPL4S10C143A 3

6. With your left hand on the fan and your right hand on the tool, move both clockwise in order to put the belt (5) onto the compressor pulley (4). Put the dust cup back onto the compressor clutch. Tighten the three screws, ensuring that you spread a film of thread lock on the ends so that they do not come loose.
7. Position the alternator (1) and the elastic belt (3). Tighten the belt tensioner (2).



WLAPL4S10C145A 4

8. Refit the cooling fan (1).

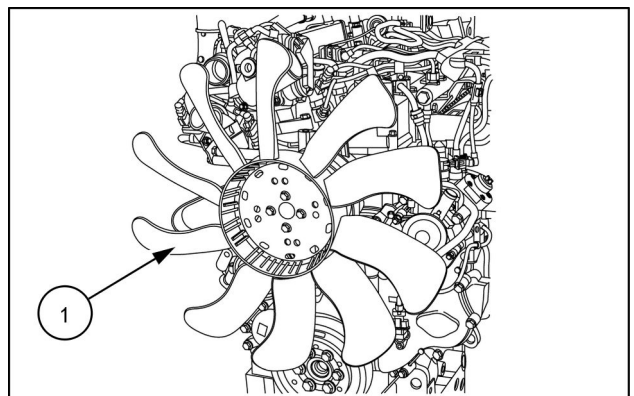

MOIL14UTL0038AA 5

<https://www.ebooklibonline.com>

Hello dear friend!

Thank you very much for reading.

Enter the link into your browser.

The full manual is available for immediate download.

<https://www.ebooklibonline.com>