

FARMALL® 45C FARMALL® 55C Tier 4B (final) Compact Tractor

*FARMALL® 45C Cab: PIN LSMF45CCxx0010001 to LSMF45CCPH0010018
FARMALL® 45C ROPS: PIN LSMF45CRxx0010001 to LSMF45CRVH0010031
FARMALL® 55C Cab: PIN LSMF55CCxx0010001 to LSMF55CCAH0010024
FARMALL® 55C ROPS: PIN LSMF55CRxx0010001 to LSMF55CRLH0010014*

SERVICE MANUAL

Part number 48144021

1st edition English
June 2017





SERVICE MANUAL

- Farmall® 45C Tier 4B (final), Cab [LSMF45CCxx0010001 -
LSMF45CCPH0010018]**
- Farmall® 45C Tier 4B (final), ROPS [LSMF45CRxx0010001 -
LSMF45CRVH0010031]**
- Farmall® 55C Tier 4B (final), Cab [LSMF55CCxx0010001 -
LSMF55CAH0010024]**
- Farmall® 55C Tier 4B (final), ROPS [LSMF55CRxx0010001 -
LSMF55CRLH0010014]**

Link Product / Engine

Product	Market Product	Engine
Farmall® 45C Tier 4B (final), ROPS [LSMF45CRxx0010001 - LSMF45CRVH0010031]	North America	L3C19-T3
Farmall® 45C Tier 4B (final), Cab [LSMF45CCxx0010001 - LSMF45CCPH0010018]	North America	L3C19-T3
Farmall® 55C Tier 4B (final), ROPS [LSMF55CRxx0010001 - LSMF55CRLH0010014]	North America	L3C19-T1
Farmall® 55C Tier 4B (final), Cab [LSMF55CCxx0010001 - LSMF55CCAH0010024]	North America	L3C19-T1

<https://www.ebooklibonline.com>

Hello dear friend!

Thank you very much for reading.

Enter the link into your browser.

The full manual is available for immediate download.

<https://www.ebooklibonline.com>

Contents

INTRODUCTION

Engine	10
[10.001] Engine and crankcase	10.1
[10.216] Fuel tanks	10.2
[10.206] Fuel filters	10.3
[10.218] Fuel injection system.....	10.4
[10.202] Air cleaners and lines	10.5
[10.254] Intake and exhaust manifolds and muffler	10.6
[10.501] Exhaust Gas Recirculation (EGR) exhaust treatment.....	10.7
[10.400] Engine cooling system	10.8
[10.414] Fan and drive	10.9
Clutch	18
[18.100] Clutch mechanical release control	18.1
[18.110] Clutch and components	18.2
Power coupling	19
[19.110] Flywheel damper	19.1
Transmission	21
[21.114] Mechanical transmission	21.1
[21.130] Mechanical transmission external controls.....	21.2
[21.140] Mechanical transmission internal components.....	21.3
[21.110] Master clutch housing	21.4
Four-Wheel Drive (4WD) system	23
[23.314] Drive shaft.....	23.1
[23.101] Mechanical control	23.2
Front axle system	25
[25.100] Powered front axle	25.1

[25.102] Front bevel gear set and differential	25.2
[25.108] Final drive hub, steering knuckles, and shafts	25.3
Rear axle system.....	27
[27.106] Rear bevel gear set and differential.....	27.1
[27.120] Planetary and final drives	27.2
Hydrostatic drive.....	29
[29.200] Mechanical control	29.1
[29.100] Transmission and steering hydrostatic control	29.2
[29.204] Reservoir, cooler, and lines	29.3
[29.218] Pump and motor components.....	29.4
[29.202] Hydrostatic transmission	29.5
Power Take-Off (PTO).....	31
[31.101] Rear mechanical control	31.1
[31.104] Rear electro-hydraulic control.....	31.2
[31.110] One-speed rear Power Take-Off (PTO)	31.3
[31.120] Central Power Take-Off (PTO)	31.4
Brakes and controls	33
[33.110] Parking brake or parking lock	33.1
[33.120] Mechanical service brakes	33.2
Hydraulic systems.....	35
[35.000] Hydraulic systems.....	35.1
[35.300] Reservoir, cooler, and filters.....	35.2
[35.104] Fixed displacement pump.....	35.3
[35.350] Safety and main relief valves	35.4
[35.204] Remote control valves	35.5
[35.114] Three-point hitch control valve	35.6
[35.116] Three-point hitch cylinder	35.7
[35.724] Front loader hydraulic system control.....	35.8

Hitches, drawbars, and implement couplings	37
[37.100] Drawbars and towing hitches	37.1
[37.108] Rear three-point hitch external controls.....	37.2
[37.110] Rear three-point hitch	37.3
Steering	41
[41.101] Steering control	41.1
[41.106] Tie rods.....	41.2
[41.200] Hydraulic control components.....	41.3
[41.216] Cylinders	41.4
[41.206] Pump	41.5
Wheels	44
[44.511] Front wheels.....	44.1
[44.520] Rear wheels	44.2
Cab climate control	50
[50.100] Heating	50.1
[50.104] Ventilation	50.2
[50.200] Air conditioning.....	50.3
[50.300] Cab pressurizing system	50.4
[50.AAA] Cab climate control generic sub-group.....	50.5
Electrical systems	55
[55.000] Electrical system	55.1
[55.100] Harnesses and connectors.....	55.2
[55.525] Cab engine controls.....	55.3
[55.015] Engine control system.....	55.4
[55.201] Engine starting system	55.5
[55.301] Alternator.....	55.6
[55.302] Battery.....	55.7
[55.011] Fuel tank system	55.8

[55.989] Exhaust Gas Recirculation (EGR) electrical system	55.9
[55.640] Electronic modules	55.10
[55.031] Parking brake electrical system	55.11
[55.512] Cab controls	55.12
[55.051] Cab Heating, Ventilation, and Air-Conditioning (HVAC) controls	55.13
[55.050] Heating, Ventilation, and Air-Conditioning (HVAC) control system	55.14
[55.023] Transmission position sensors and switches	55.15
[55.052] Central or middle Power Take-Off (PTO) control system	55.16
[55.610] Ground speed control	55.17
[55.DTC] FAULT CODES	55.18
Platform, cab, bodywork, and decals	90
[90.150] Cab	90.1
[90.110] Operator platform less cab	90.2
[90.114] Operator protections	90.3
[90.120] Mechanically-adjusted operator seat	90.4
[90.100] Engine hood and panels	90.5
[90.116] Fenders and guards	90.6



INTRODUCTION

Foreword - Important notice regarding equipment servicing

All repair and maintenance work listed in this manual must be carried out only by qualified dealership personnel, strictly complying with the instructions given, and using, whenever possible, the special tools.

Anyone who performs repair and maintenance operations without complying with the procedures provided herein shall be responsible for any subsequent damages.

The manufacturer and all the organizations of its distribution chain, including - without limitation - national, regional, or local dealers, reject any responsibility for damages caused by parts and/or components not approved by the manufacturer, including those used for the servicing or repair of the product manufactured or marketed by the manufacturer. In any case, no warranty is given or attributed on the product manufactured or marketed by the manufacturer in case of damages caused by parts and/or components not approved by the manufacturer.

The manufacturer reserves the right to make improvements in design and changes in specifications at any time without notice and without incurring any obligation to install them on units previously sold. Specifications, descriptions, and illustrative material herein are as accurate as known at time of publication but are subject to change without notice.

In case of questions, refer to your CASE IH Sales and Service Networks.

Safety rules

Personal safety





This is the safety alert symbol. It is used to alert you to potential personal injury hazards. Obey all safety messages that follow this symbol to avoid possible death or injury.

Throughout this manual you will find the signal words DANGER, WARNING, and CAUTION followed by special instructions. These precautions are intended for the personal safety of you and those working with you.

Read and understand all the safety messages in this manual before you operate or service the machine.

 DANGER indicates a hazardous situation that, if not avoided, will result in death or serious injury.

 WARNING indicates a hazardous situation that, if not avoided, could result in death or serious injury.

 CAUTION indicates a hazardous situation that, if not avoided, could result in minor or moderate injury.

FAILURE TO FOLLOW DANGER, WARNING, AND CAUTION MESSAGES COULD RESULT IN DEATH OR SERIOUS INJURY.

Machine safety

NOTICE: Notice indicates a situation that, if not avoided, could result in machine or property damage.

Throughout this manual you will find the signal word Notice followed by special instructions to prevent machine or property damage. The word Notice is used to address practices not related to personal safety.

Information

NOTE: Note indicates additional information that clarifies steps, procedures, or other information in this manual.

Throughout this manual you will find the word Note followed by additional information about a step, procedure, or other information in the manual. The word Note is not intended to address personal safety or property damage.

Safety rules - Ecology and the environment

Soil, air, and water quality is important for all industries and life in general. When legislation does not yet rule the treatment of some of the substances that advanced technology requires, sound judgment should govern the use and disposal of products of a chemical and petrochemical nature.

Familiarize yourself with the relative legislation applicable to your country, and make sure that you understand this legislation. Where no legislation exists, obtain information from suppliers of oils, filters, batteries, fuels, anti-freeze, cleaning agents, etc., with regard to the effect of these substances on man and nature and how to safely store, use, and dispose of these substances.

Helpful hints

- Avoid the use of cans or other inappropriate pressurized fuel delivery systems to fill tanks. Such delivery systems may cause considerable spillage.
- In general, avoid skin contact with all fuels, oils, acids, solvents, etc. Most of these products contain substances that may be harmful to your health.
- Modern oils contain additives. Do not burn contaminated fuels and or waste oils in ordinary heating systems.
- Avoid spillage when you drain fluids such as used engine coolant mixtures, engine oil, hydraulic fluid, brake fluid, etc. Do not mix drained brake fluids or fuels with lubricants. Store all drained fluids safely until you can dispose of the fluids in a proper way that complies with all local legislation and available resources.
- Do not allow coolant mixtures to get into the soil. Collect and dispose of coolant mixtures properly.
- The air-conditioning system contains gases that should not be released into the atmosphere. Consult an air-conditioning specialist or use a special extractor to recharge the system properly.
- Repair any leaks or defects in the engine cooling system or hydraulic system immediately.
- Do not increase the pressure in a pressurized circuit as this may lead to a component failure.
- Protect hoses during welding. Penetrating weld splatter may burn a hole or weaken hoses, allowing the loss of oils, coolant, etc.

Battery recycling

Batteries and electric accumulators contain several substances that can have a harmful effect on the environment if the batteries are not properly recycled after use. Improper disposal of batteries can contaminate the soil, groundwater, and waterways. CASE IH strongly recommends that you return all used batteries to a CASE IH dealer, who will dispose of the used batteries or recycle the used batteries properly. In some countries, this is a legal requirement.



Mandatory battery recycling

NOTE: The following requirements are mandatory in Brazil.

Batteries are made of lead plates and a sulfuric acid solution. Because batteries contain heavy metals such as lead, CONAMA Resolution 401/2008 requires you to return all used batteries to the battery dealer when you replace any batteries. Do not dispose of batteries in your household garbage.

Points of sale are obliged to:

- Accept the return of your used batteries
- Store the returned batteries in a suitable location
- Send the returned batteries to the battery manufacturer for recycling



SERVICE MANUAL

Engine

- Farmall® 45C Tier 4B (final), Cab [LSMF45CCxx0010001 -
LSMF45CCPH0010018]**
- Farmall® 45C Tier 4B (final), ROPS [LSMF45CRxx0010001 -
LSMF45CRVH0010031]**
- Farmall® 55C Tier 4B (final), Cab [LSMF55CCxx0010001 -
LSMF55CCAH0010024]**
- Farmall® 55C Tier 4B (final), ROPS [LSMF55CRxx0010001 -
LSMF55CRLH0010014]**

Engine - Remove

Prior operation:

Drain fluid **Hydrostatic transmission - Change fluid (29.202)**

Prior operation:

Drain fluid **Mechanical transmission - Change fluid (21.114)**

Prior operation:

Hood - Remove (90.100)

Prior operation:

Radiator - Remove (10.400)

NOTE: Note the placement of cable ties for reassembly.

1. Remove the two M8 flange bolts (1) securing the rear cowling.
2. Remove the rear cowling (2).

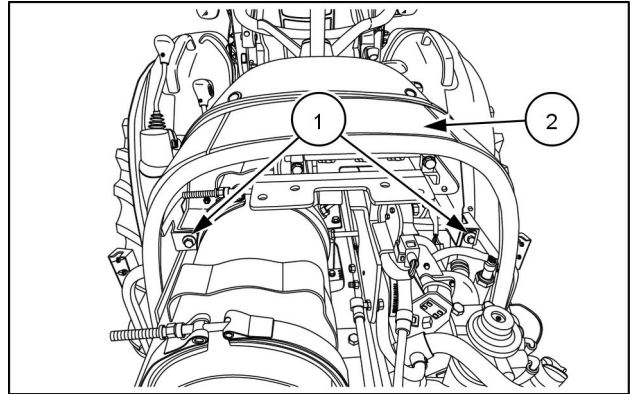

NHIL16CT01367AA 1

3. Remove the four M10 bolts (2) that mount the hood support bracket (1) to the flywheel housing.

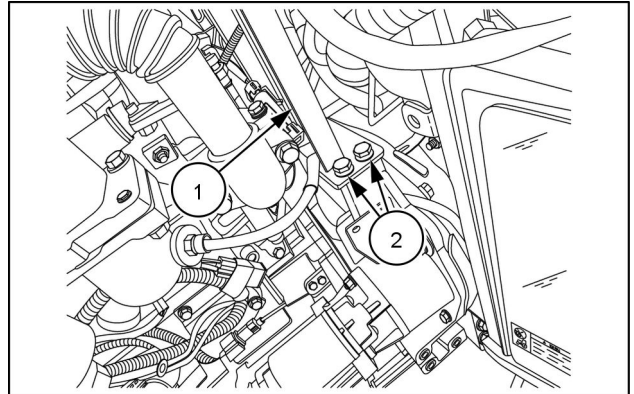

NHIL16CT01398AA 2

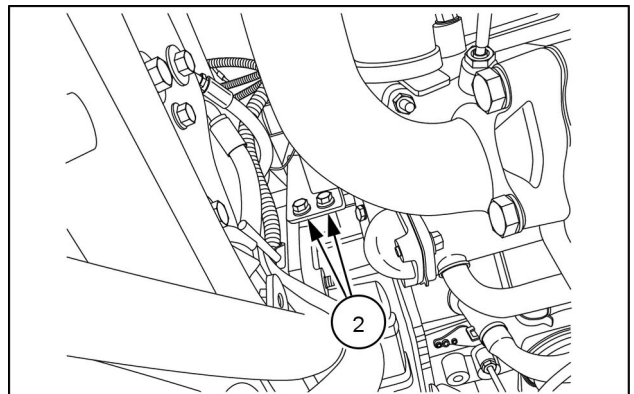

NHIL16CT01400AA 3

4. Remove the M8 bolt **(1)** in the front of the Four Wheel Drive (FWD) guard tube.
5. Slide the guard tube rear-ward.

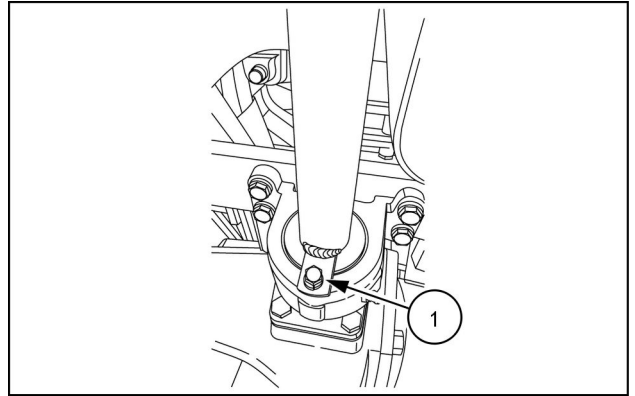

NHIL16CT01006AA 4

6. Use a roll pin punch and a hammer and drive the roll pin **(1)** through the coupler.
7. Slide the coupler rear-ward.

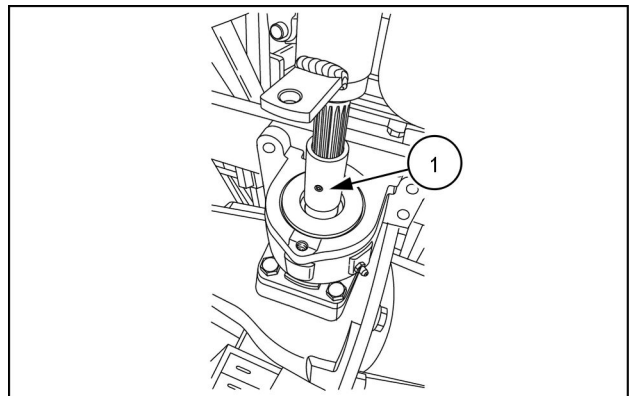

NHIL16CT00679AA 5

Right-hand side

8. Remove the M6 bolt **(1)** and remove the ground wire **(2)** from the bell housing.

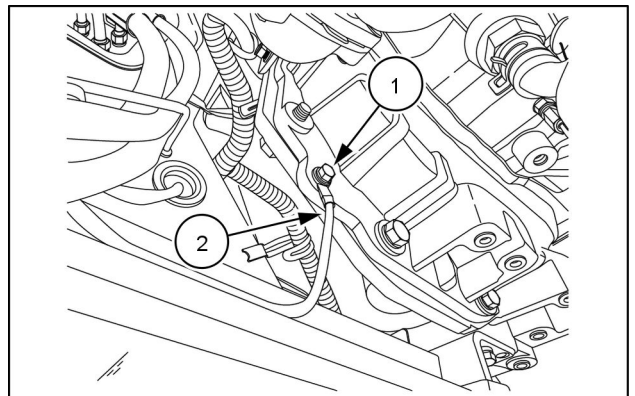

NHIL16CT01383AA 6

9. Cut the cable ties **(1)** from the right-hand and left-hand steering hoses.

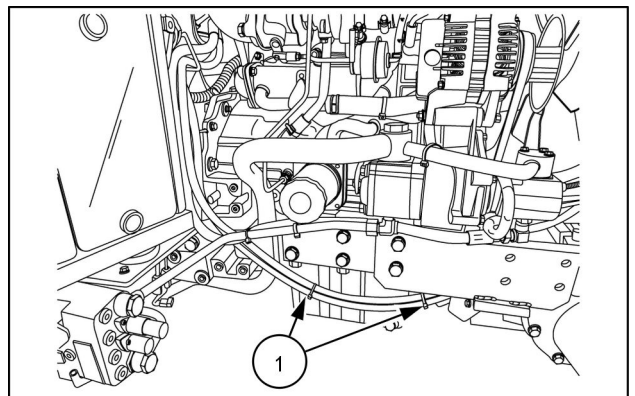

NHIL16CT01377AA 7

10. Disconnect the right-hand and left-hand steering hoses (1).

NOTE: Cap off all hydraulic and fuel fittings or tubes to prevent contamination.

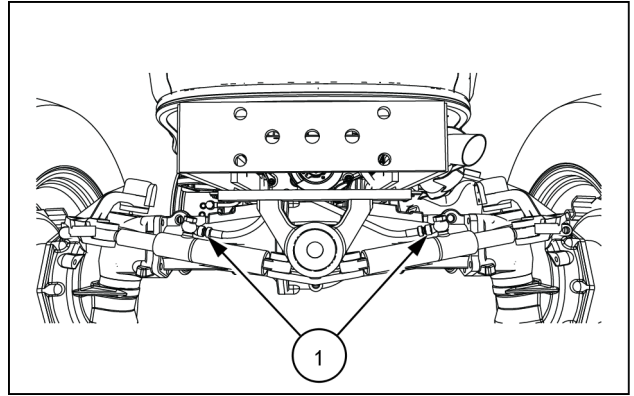

NHIL16CT01037AA 8

11. Remove the steering hoses from the top of the front axle by unfolding the hose stays (1).
12. Route the steering hoses from under the front frame and place them away from the engine.

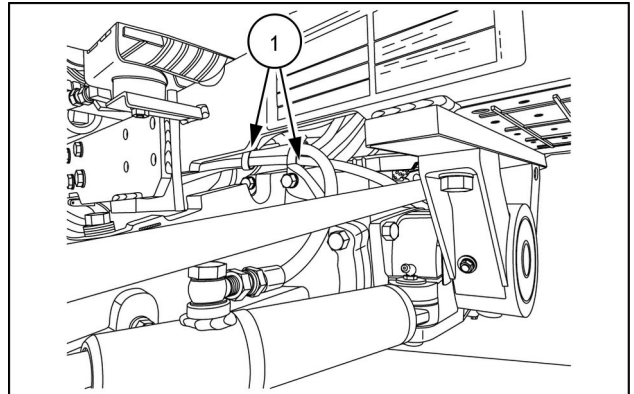

NHIL16CT00995AA 9

13. Loosen the hose clamps (1) and slide the suction tube coupler (2) rear-ward.

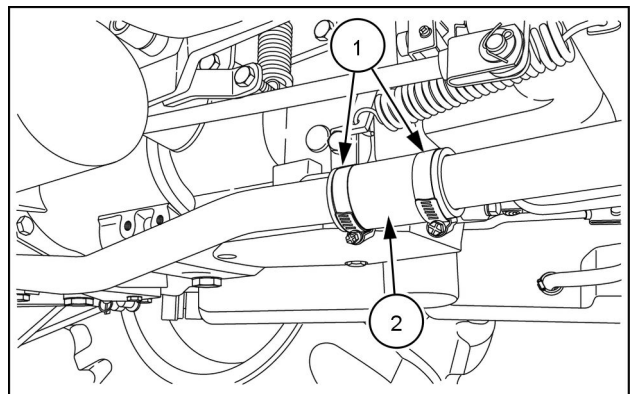

NHIL16CT00550AA 10

14. Remove the banjo bolt **(2)** from the main hydraulic pump.
15. Remove the three M6 bolts **(3)** from the steering pump suction fitting **(4)**.
16. Remove the suction tube **(5)**.
17. Disconnect the steering pump outlet hose **(6)**. Cap off the hose and route the hose away from the engine.
18. Disconnect the main hydraulic pump outlet pipe **(7)**.
19. For Roll Over Protective Structure (ROPS) tractor:
 1. Disconnect the steering pump outlet hose **(6)**. Cap off the hose and route the hose away from the engine.
20. For mechanical transmissions:
 1. Remove the banjo bolt **(8)** from the Mid Mount Valve (MMV) pressure port.
 2. Remove the main hydraulic pump outlet pipe **(1)** from the MMV.
21. For Hydro-Static Transmissions (HST):
 1. Remove the main hydraulic pump outlet pipe **(1)** from the union fitting **(2)**.

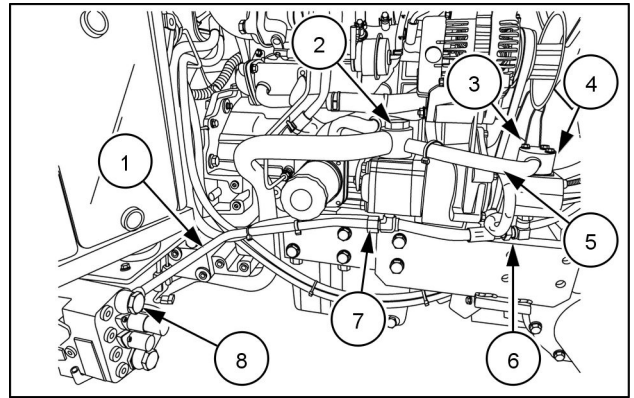

NHIL16CT01377AA 11

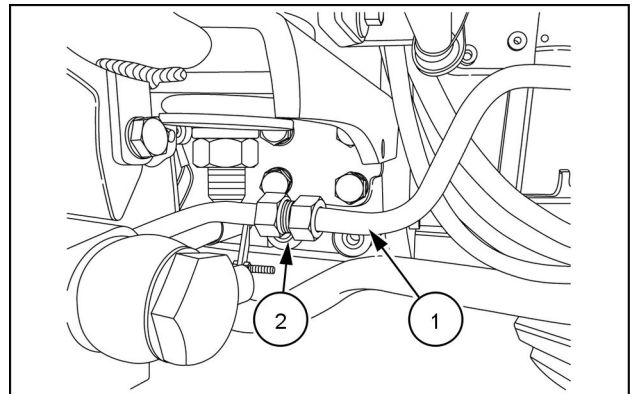

NHIL15CT00802AA 12

Cab tractor only

22. Disconnect the steering pressure hose **(2)** at the back side of the resonator **(1)**. Cap off the hose and route the hose away from the engine.

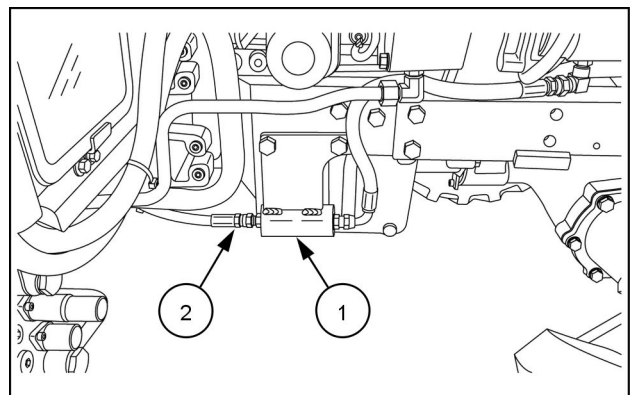

NHIL17CT00216AA 13

23. Disconnect the two heater coolant hoses (1) on the right side of the machine.

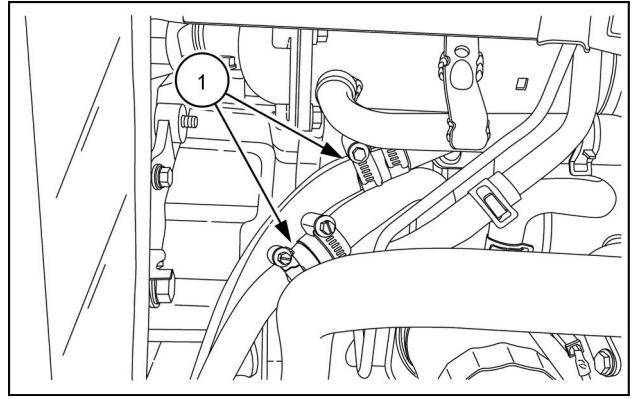

NHIL16CT01417AA 14

24. Disconnect the air conditioning lines at quick disconnects (1) on the left side of the machine.

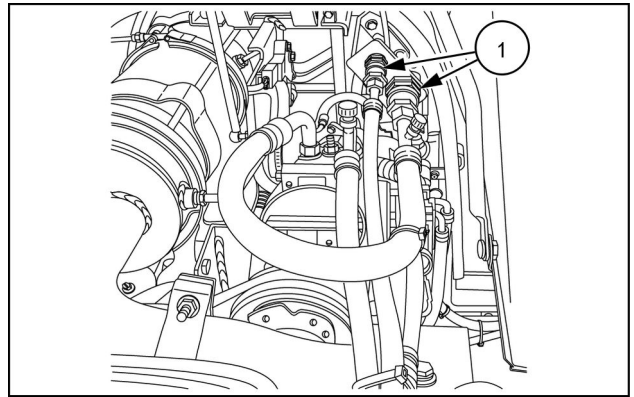

NHIL16CT01488AA 15

Left-hand side

25. Remove the coated nut and remove the shield (1) from the starter motor solenoid.

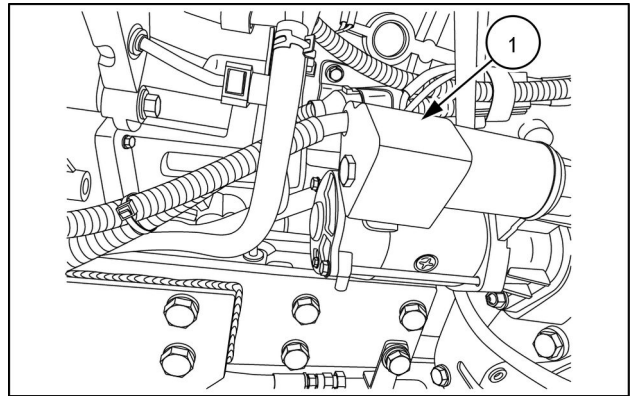

NHIL16CT01381AA 16

26. Remove the M8 flange nut and remove the power cable (1) from the stud.

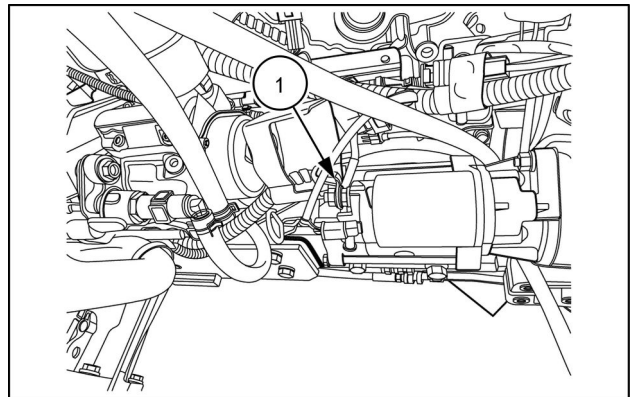

NHIL16CT01385AA 17

27. Disconnect the Engine Control Unit (ECU) electrical connector **(1)** near the middle of the engine crankcase.

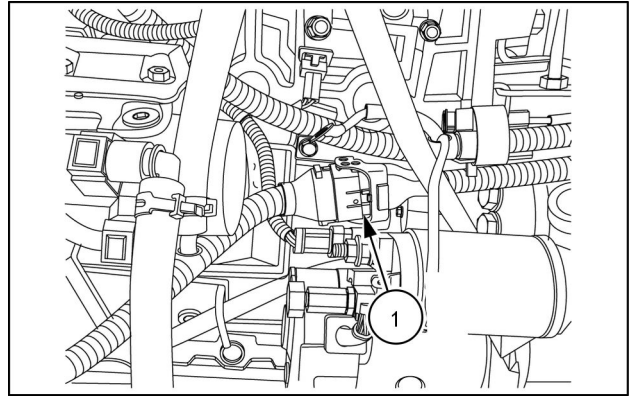

NHIL16CT01386AA 18

28. Disconnect the power and ground electrical connectors **(1)** above the starter motor.

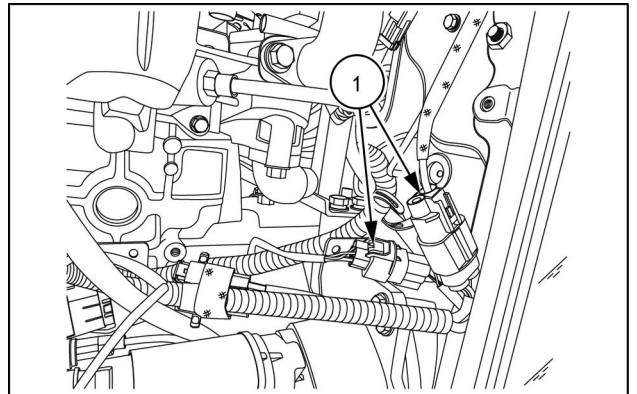

NHIL16CT01387AA 19

29. Disconnect the fuel supply hose **(1)** from the fuel water separator filter to the fuel tank.
 30. Disconnect the fuel return hose **(3)** from the high-pressure fuel pump.
 31. Disconnect the fuel return hose **(2)** from the fuel tank.

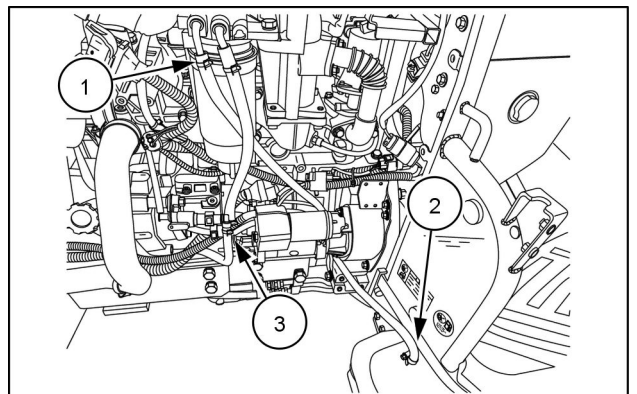

NHIL16CT01379AA 20

32. Disconnect the two hydraulic oil cooler lines **(1)**.
 33. Route the hydraulic oil cooler hoses toward the front of the tractor.

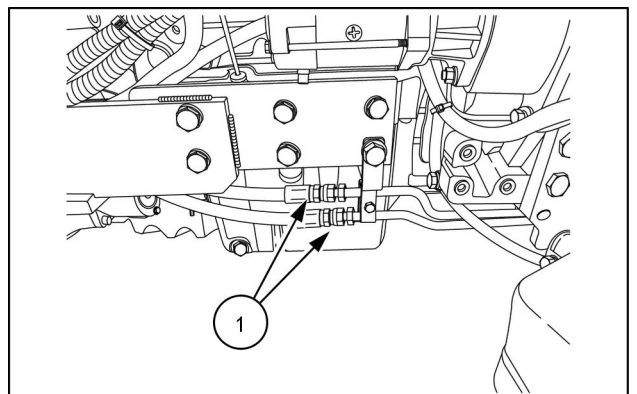

NHIL16CT01380AA 21

34. Disconnect the glow plug electrical connector **(3)**.
35. Remove the M8 bolt **(2)** from the Catalyzed Continuously Regenerating Trap (CCRT) bracket.
36. Disconnect the Differential Pressure Sensor (DPS) input hoses **(4)**.
37. Disconnect the DPS electrical connector **(1)**.

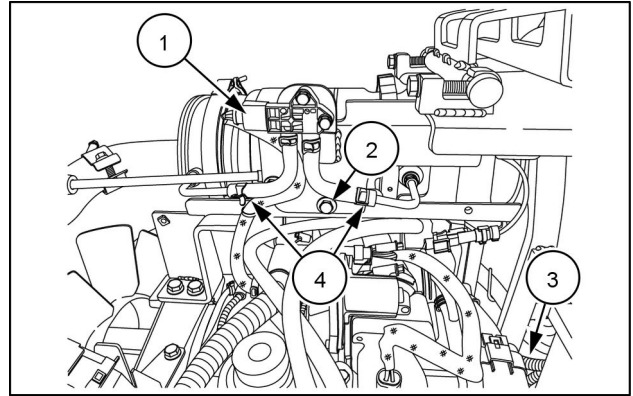

NHIL16CT01399AA 22

Front frame

38. Support the engine and transmission section independent of front frame..
39. Insert wooden wedge blocks between the front frame and front axle housing.
40. Remove the six M14 bolts **(1)** on the right-hand and left-hand sides of the front frame.

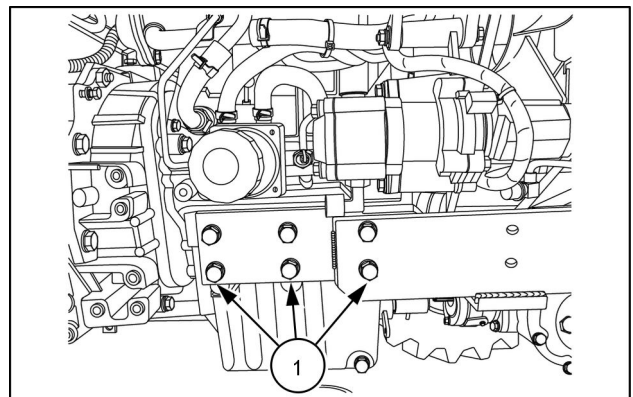

NHIL16CT01397AA 23

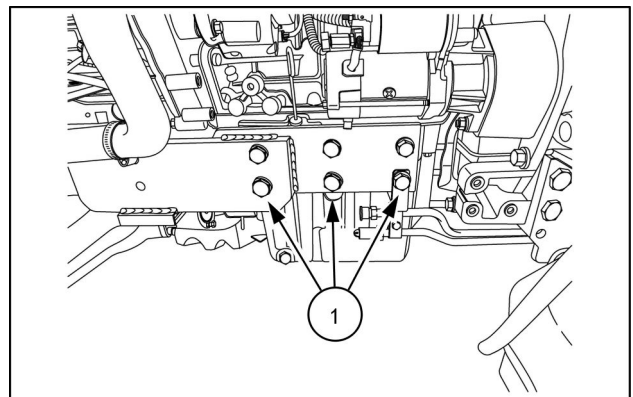

NHIL16CT01390AA 24

41. Roll the front frame away from the engine. Support the front frame with a jack stand.

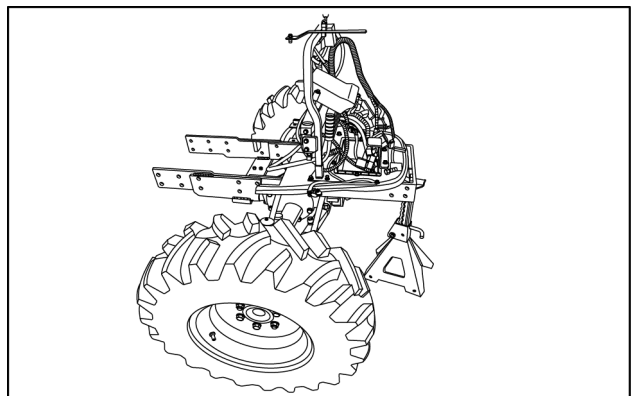

NHIL16CT01401AA 25

Separating engine from transmission

42. Remove the M10 bolt **(2)** from the rear Four-Wheel Drive (FWD) guard tube.
43. Remove the guard tube **(3)** and drive-shaft **(3)**.

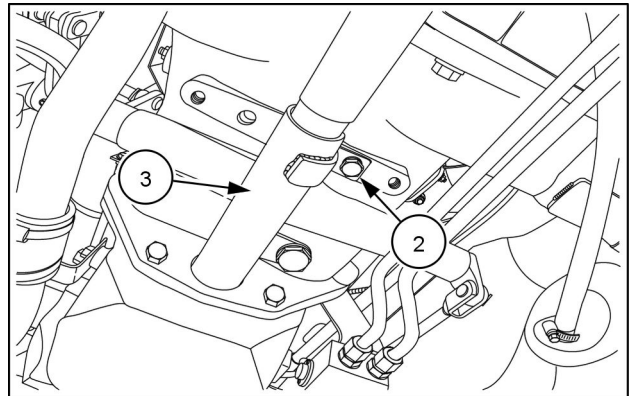

NHIL16CT01376AA 26

44. Support the engine with appropriate lifting equipment.
45. Remove the M12 two bolts **(1)** on the bottom of the bell housing.

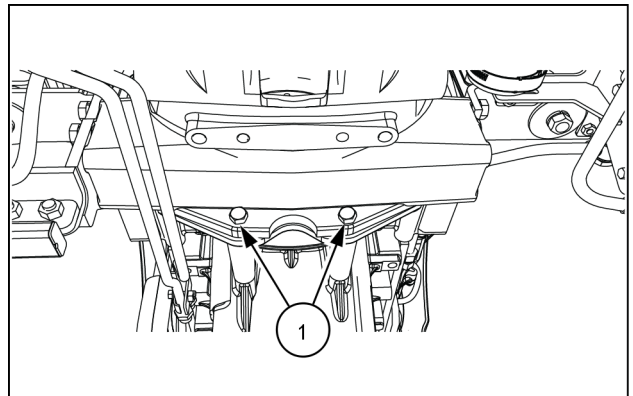

NHIL16CT01038AA 27

46. Remove the four M12 bolts **(1)** on the right-hand side of machine.

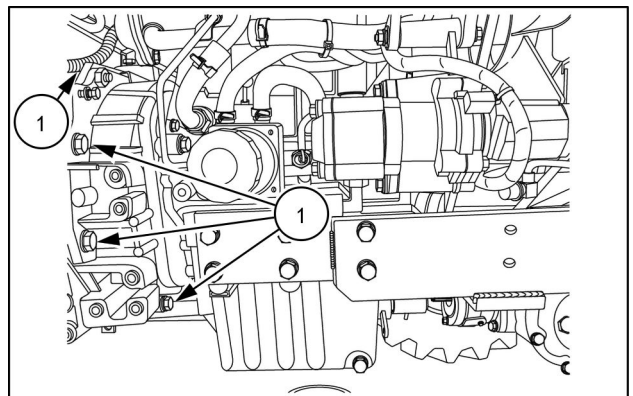

NHIL16CT01397AA 28

47. Remove the four M12 bolts (1) on the left-hand side of machine..

NOTE: The M12 bolt on the top left-hand side is assessable by removing the rubber plug (2) in the operators station.

48. Pry the engine away from the transmission section.
49. Slide the engine off the input shafts and dowel pins. Separate the engine from the transmission section.

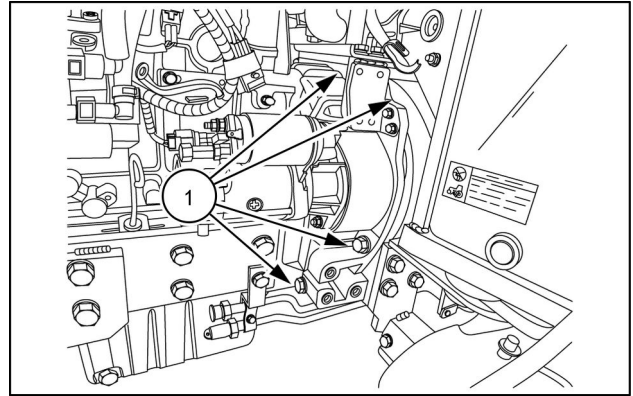

NHIL16CT01391AA 29

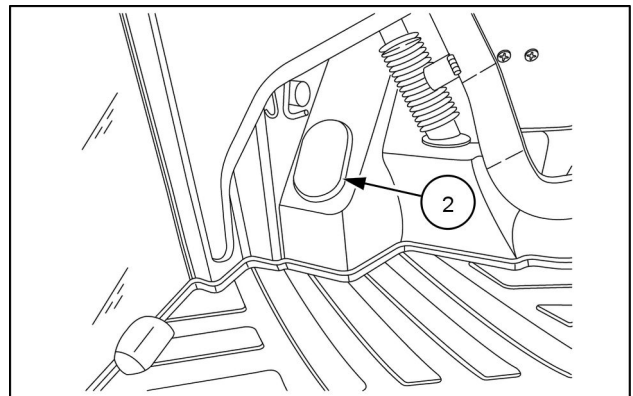

NHIL16CT01392AA 30

Engine - Install

Joining the engine to the transmission section

1. Clean the joining surfaces of the engine and the transmission.
2. Slide the engine towards the transmission.
3. Align the engine with the input shafts of the transmission and the dowel pins.
4. Push the engine against the joining surface of the transmission.

NOTE: If the engine will not join completely with the transmission turn the crankshaft slowly to align the engine with the transmission input shaft splines.

5. Install the ten M12 bolts (1). Torque to **108 N·m (80 lb ft)**

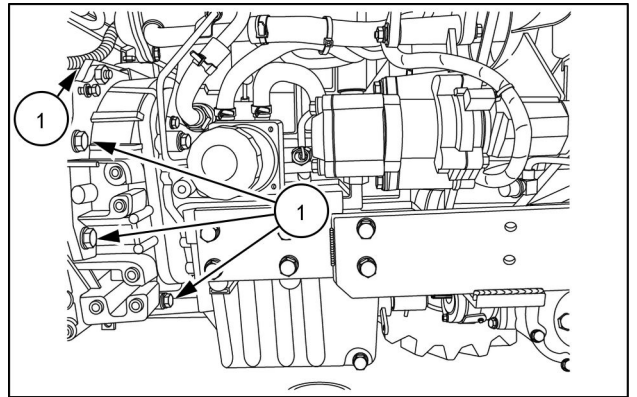

NHIL16CT01397AA 1

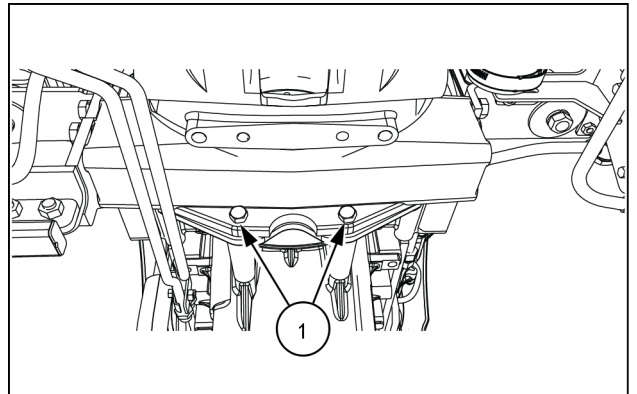

NHIL16CT01038AA 2

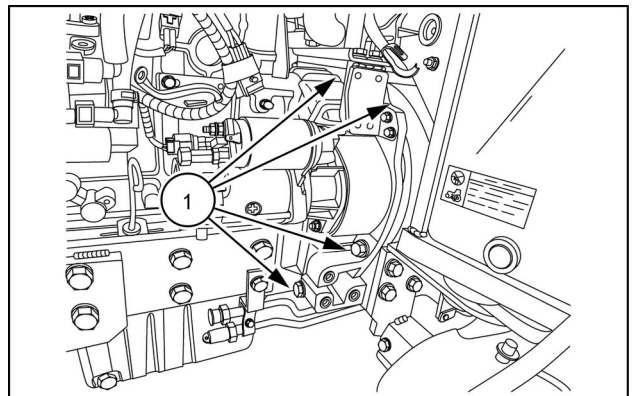

NHIL16CT01391AA 3

6. Install the Four Wheel Drive (FWD) drive shaft (3) and guard tube (3).
7. Install the M10 bolt (1) in the rear of the guard tube.

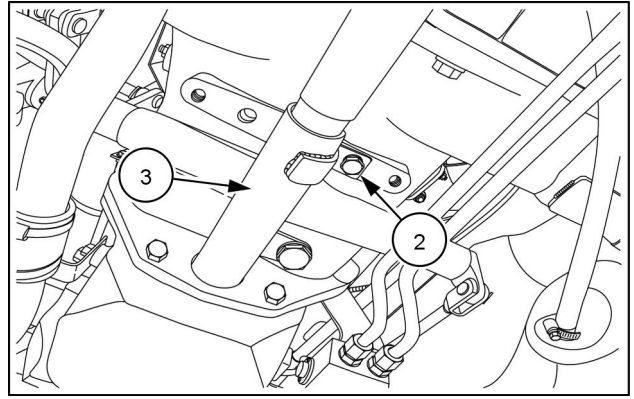

NHIL16CT01376AA 4

8. Position the hood hinge support bracket (1) on the engine bell-housing.
9. Install the four M10 bolts (2) from the hood hinge support bracket. Tighten the hardware.

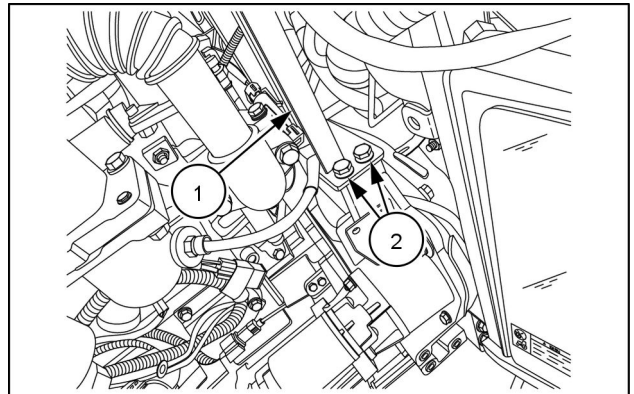

NHIL16CT01398AA 5

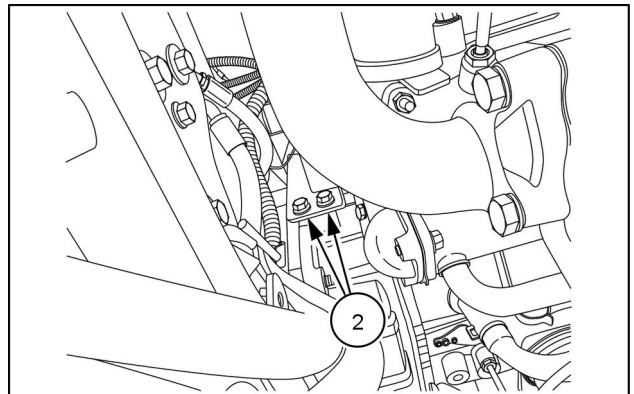

NHIL16CT01400AA 6

Joining the front frame to engine

10. Roll the front frame into position.

NOTE: Be sure the drive shaft coupler is installed on the forward section of the drive shaft.

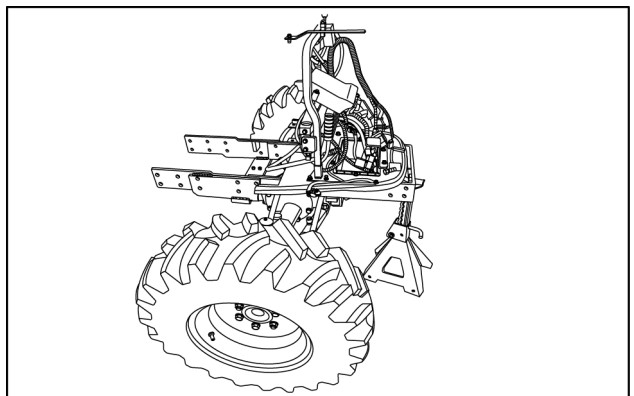

NHIL16CT01401AA 7

11. Install the six M14 bolts **(1)** on the right-hand and left-hand sides of the front frame.
12. Torque the M14 bolts to **140 N·m (103 lb ft)**
13. Remove the wooden wedge blocks between the front frame and the front axle housing.
14. Remove the support stands.

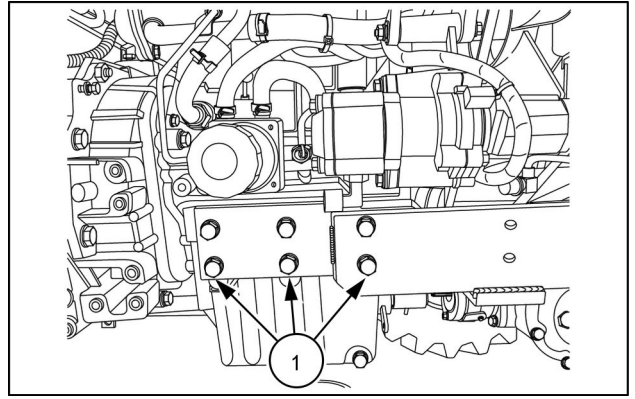

NHIL16CT01397AA 8

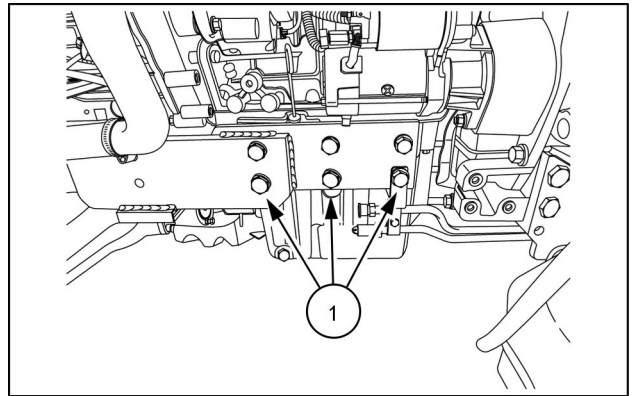

NHIL16CT01390AA 9

15. Center the FWD coupler **(1)** on the drive shaft and front axle input shaft.
16. Install the roll-pin in the coupler.

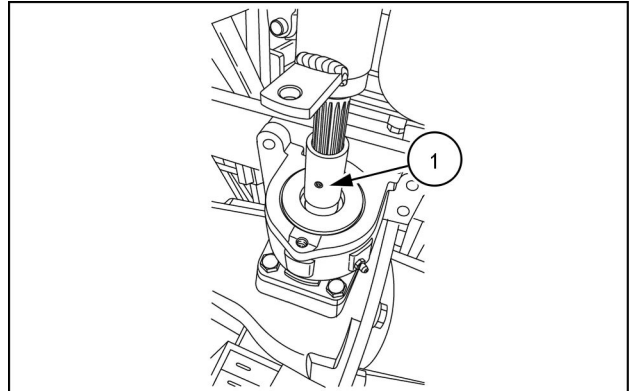

NHIL16CT00679AA 10

17. Slide the guard tube forward and secure the guard tube to the front axle housing using the M8 bolt **(1)**. Tighten the hardware.

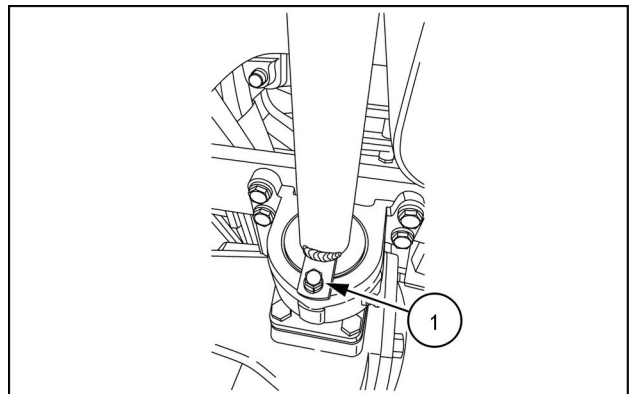

NHIL16CT01006AA 11

Left-hand side

18. Connect the Differential Pressure Sensor (DPS) electrical connector **(1)**.
19. Connect the DPS input hoses **(4)**.
20. Install the M8 bolt **(2)** from the Catalyzed Continuously Regenerating Trap (CCRT) bracket. Tighten the hardware.
21. Connect the glow plug electrical connector **(3)**.

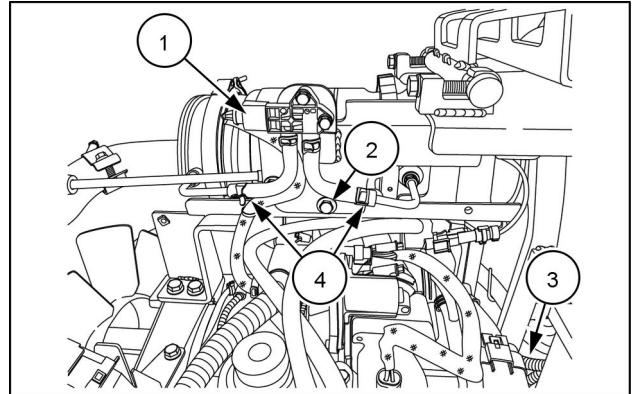

NHIL16CT01399AA 12

22. Connect the fuel return hose **(2)** from the fuel tank.
23. Connect the fuel return hose **(3)** from the right-hand fitting on the fuel cooler to the high-pressure fuel pump return fitting.
24. Connect the fuel supply hose **(1)** from the fuel tank to the fuel water separator filter.

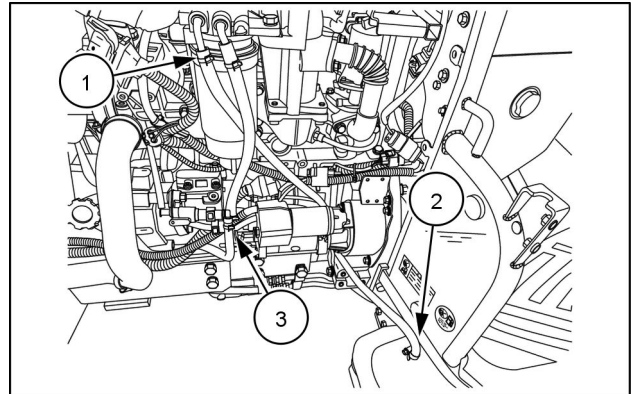

NHIL16CT01379AA 13

25. Route the hydraulic oil cooler hoses. **(1)** toward the oil cooler steel lines.
26. Connect the two hydraulic oil cooler lines **(1)**. Tighten the fittings.

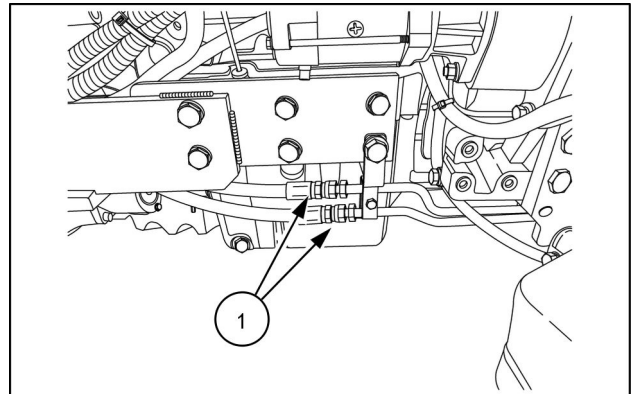

NHIL16CT01380AA 14

27. Connect the Engine Control Unit (ECU) electrical connector **(1)** near the middle of the engine crankcase.

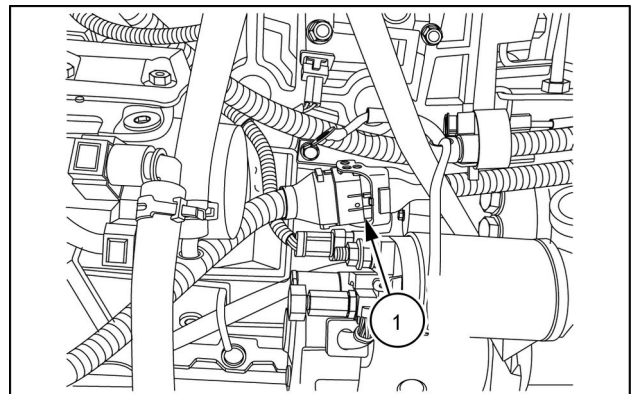

NHIL16CT01386AA 15

28. Connect the power and ground electrical connectors **(1)** above the starter motor.

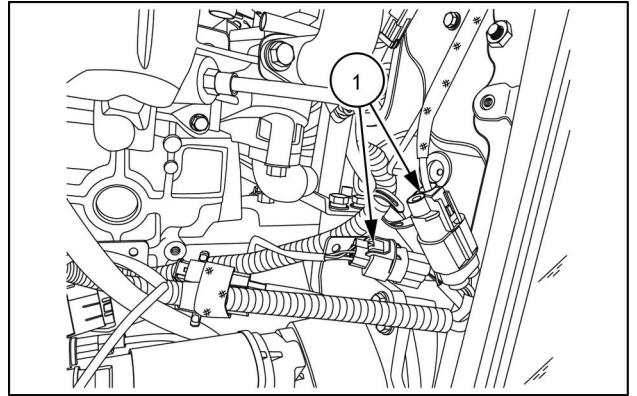

NHIL16CT01387AA 16

29. Install the power wire **(1)** on the M8 stud on the starter motor solenoid.
 30. Install the M8 nut on the start motor solenoid. Tighten the hardware.

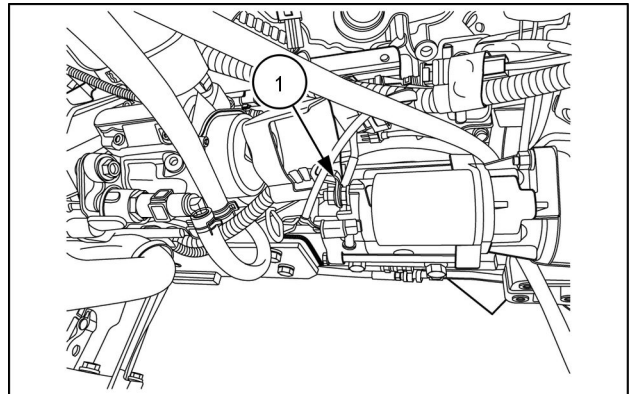

NHIL16CT01385AA 17

31. Install the starter motor solenoid shield **(1)**.

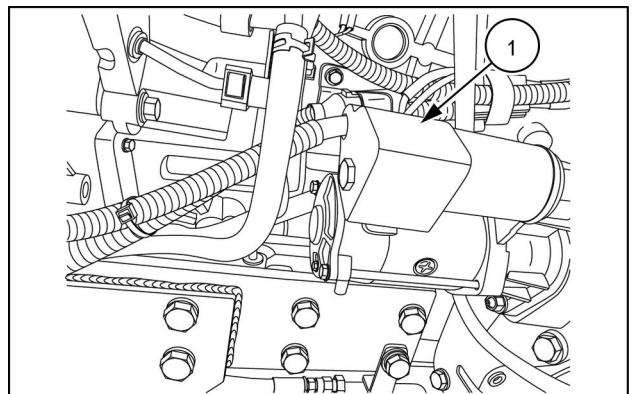

NHIL16CT01381AA 18

Right-hand side

32. Position the suction tube **(5)** on the hydraulic pumps.
 33. Install the three M6 bolts **(3)** on the steering pump suction fitting **(4)**. Tighten the hardware.
 34. Install the banjo bolt **(2)** on the main hydraulic pump using new sealing washers. Tighten the secure line to banjo bolt.
 35. For Roll Over Protective Structure (ROPS) tractor:
 1. Connect the steering pump outlet hose **(6)**. Tighten the fitting.

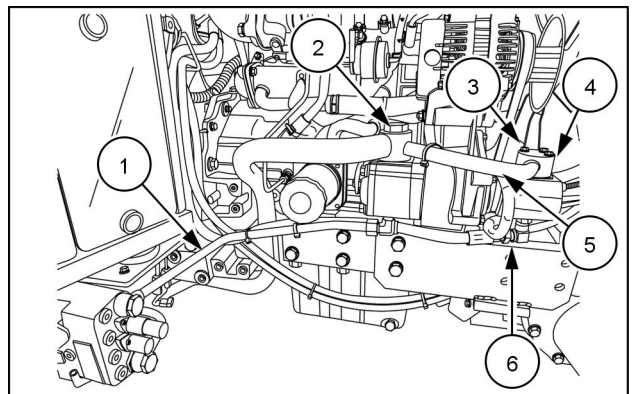

NHIL16CT01377AA 19

36. Position the suction tube coupler **(2)** so both suction tube ends are connected. Tighten the clamps **(1)**.

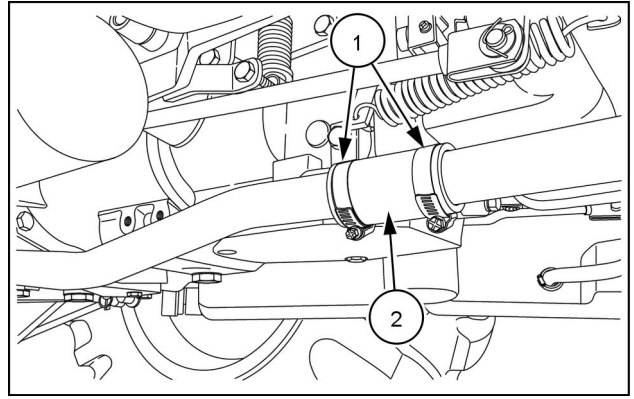

NHIL16CT00550AA 20

37. Route the steering hoses under the front frame and on top of the front axle housing.
38. Attach the hoses to the front axle housing by wrapping them in the hose stays **(1)**.

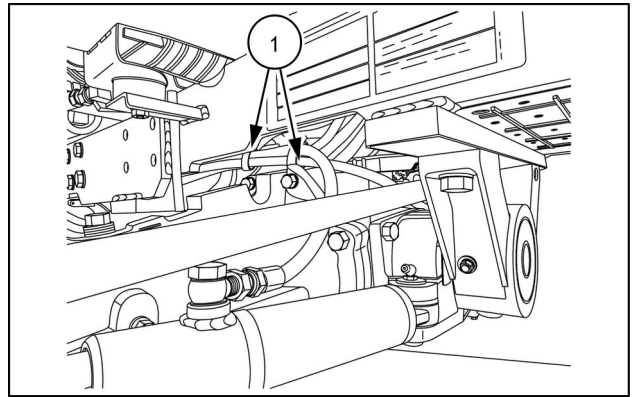

NHIL16CT00995AA 21

39. Connect the right-hand and left-hand steering hoses **(1)**. Tighten the fittings.

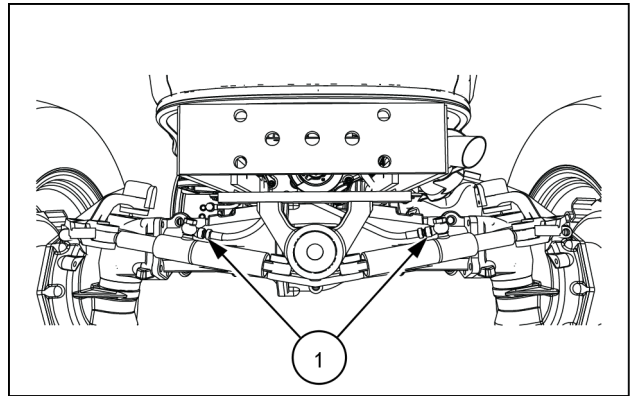

NHIL16CT01037AA 22

40. Attach the ground wire **(2)** to the bell housing by using the M6 bolt **(1)**. Tighten the hardware.

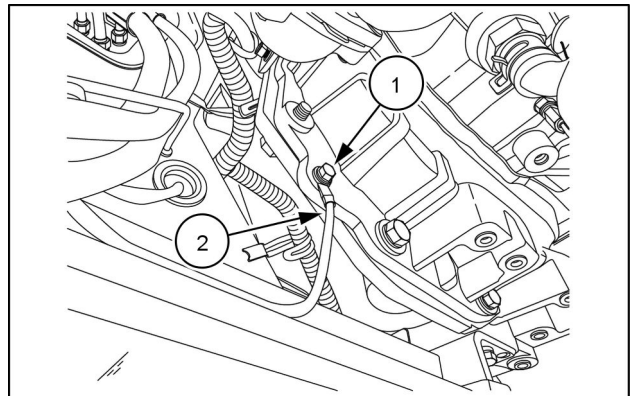

NHIL16CT01383AA 23

41. For mechanical transmissions:

1. Install the main hydraulic pump outlet pipe (1) to the hydraulic pump (2) . Don not tighten fitting at this time..
2. Install the banjo bolt (3) to secure line to the Mid Mount Valve (MMV).
3. Tighten banjo bolt at MMV and fitting at hydraulic pump at this time.

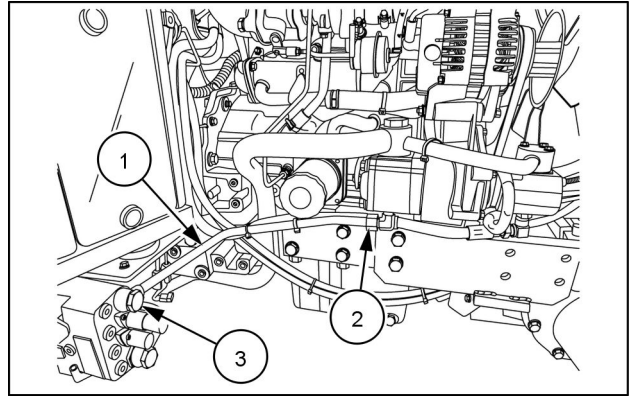

NHIL16CT01377AA 24

42. For Hydro-Static Transmissions (HST):

1. Connect the main hydraulic pump outlet pipe (1) to the union fitting (2). Tighten fitting

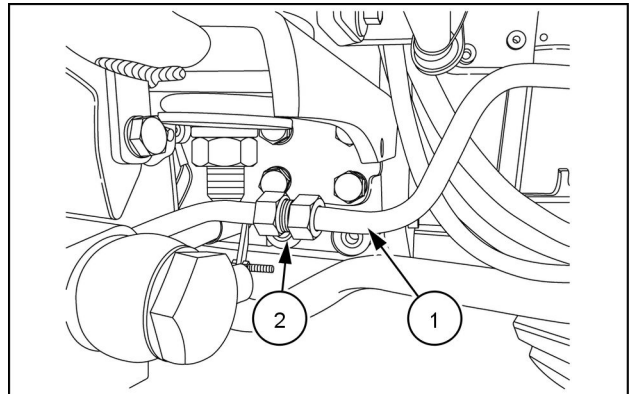

NHIL15CT00802AA 25

Cab tractor only

43. Connect the steering pressure hose (2) at the back side of the resonator (1). Tighten the fitting.

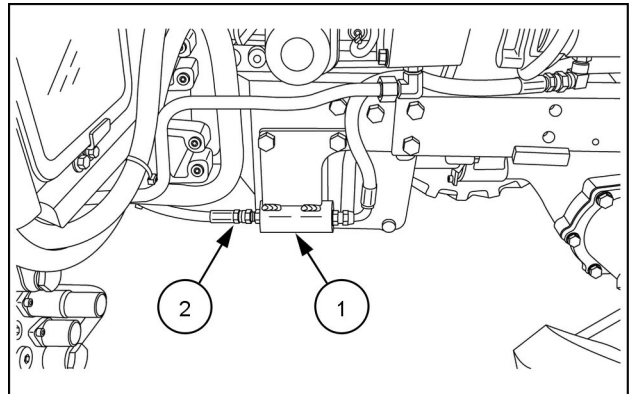

NHIL17CT00216AA 26

44. Connect the two heater coolant hoses (1), located on the right-hand side of the machine.

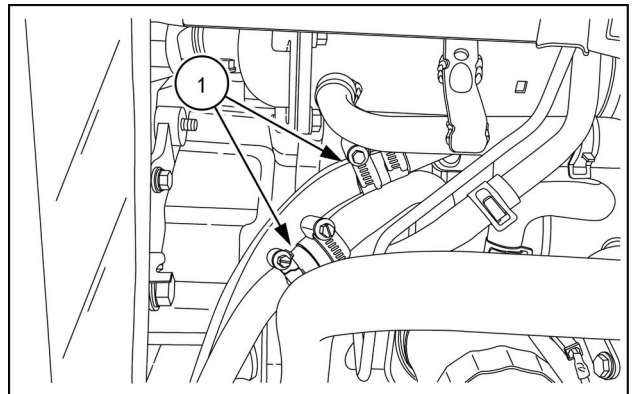

NHIL16CT01417AA 27

45. Disconnect the air conditioning lines at quick disconnects **(1)**, located on the left-hand side of the machine.

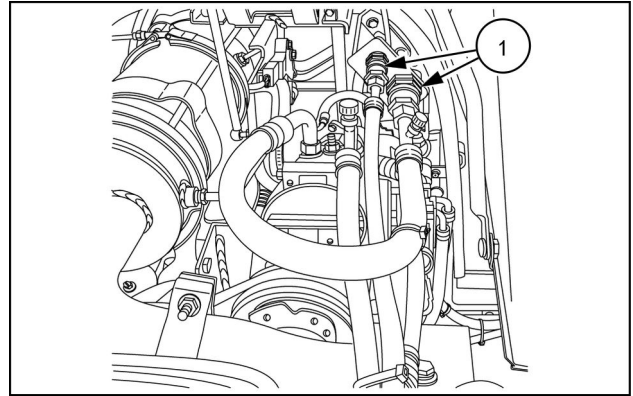

NHIL16CT01488AA 28

Final Assembly

46. Position the rear cowling **(2)** .
47. Install the two M8 bolts **(1)**. Tighten the hardware.

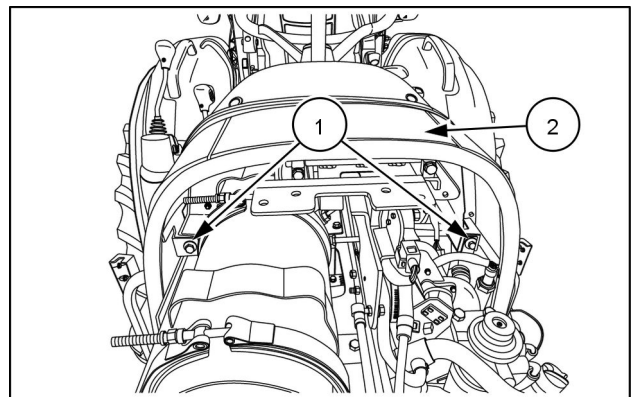

NHIL16CT01367AA 29

Next operation:

Radiator - Install (10.400)

Next operation:

Hood - Install (90.100)

Next operation:

Refill transmission with oil. **Hydrostatic transmission - Change fluid (29.202) / Mechanical transmission - Change fluid (21.114)**

Engine - Change fluid - Oil and filter

⚠ CAUTION

Burn hazard!

Do not handle any service fluid (engine coolant, engine oil, hydraulic oil, etc.) at temperatures that exceed 49 °C (120 °F). Allow fluids to cool before proceeding.

Failure to comply could result in minor or moderate injury.

C0107B

⚠ WARNING

Jack stands can slip or fall over. Dropping, tipping, or slipping of machine or its components is possible.

DO NOT work under a vehicle supported by jack stands only. Park machine on a level surface. Block wheels. Support machine with safety stands.

Failure to comply could result in death or serious injury.

W0069A

NOTE: Change the engine oil and filter after the first 50 hours of operation, then every 300 hours thereafter. If the tractor is in operation for extended periods at maximum rated power and speed, or under other types of continuous, severe operating conditions, change the engine oil, and filter at 200-hour intervals following the initial oil change.

To change the engine oil, do the following:

1. Place a suitable container beneath the drain opening to catch the used oil. With the tractor engine off but at normal operating temperature, remove the two drain plugs, (1) and (2), located on both sides of the engine oil pan. Install the plugs after draining the oil.

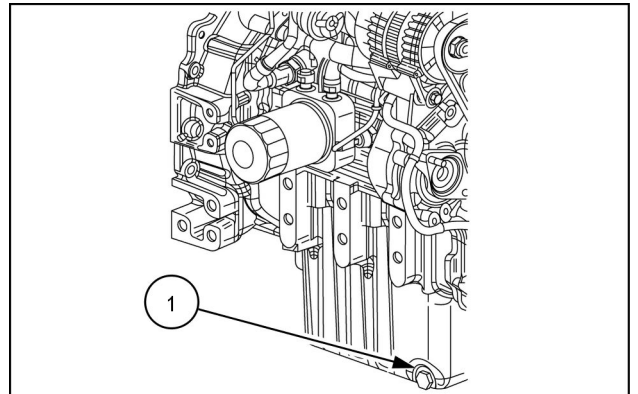

NHIL16CT00447AA 1

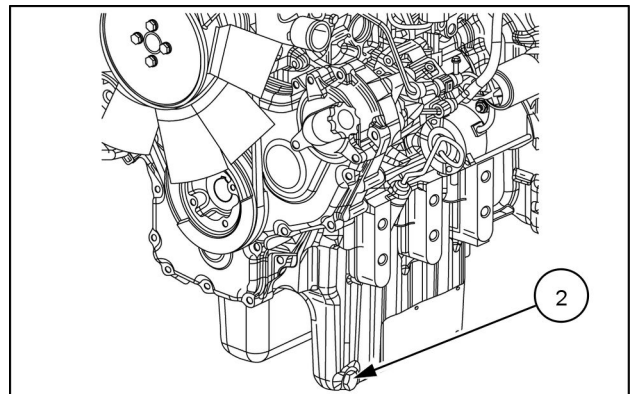

NHIL16CT00449AA 2



Suggest:

If the above button click is invalid.

Please download this document

first, and then click the above link

to download the complete manual.

Thank you so much for reading

2. Next, place a container below the oil filter, **(3)**, to catch the used oil and unscrew the oil filter. Discard the used oil and filter.
3. Coat the gasket on the new filter with a film of clean oil. Screw the filter into place until the gasket contacts the mating surface, and then turn the filter approximately three-quarters of a turn by hand. Do not overtighten.

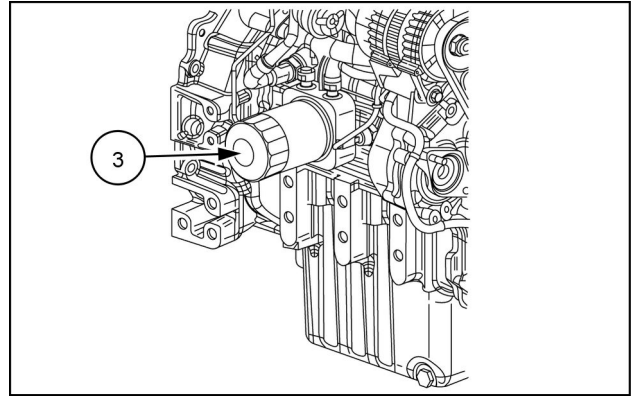

NHIL16CT00447AA 3

4. Add the specified type and amount of new oil at fill port **(4)**, then start the engine and check the filter for leaks.

NOTE: Oil Capacity, with filter 5.0 l (5.3 US qt)

NOTICE: Use of any engine oil other than (CJ-4) may clog the (DPF) earlier than expected and fuel usage may increase.

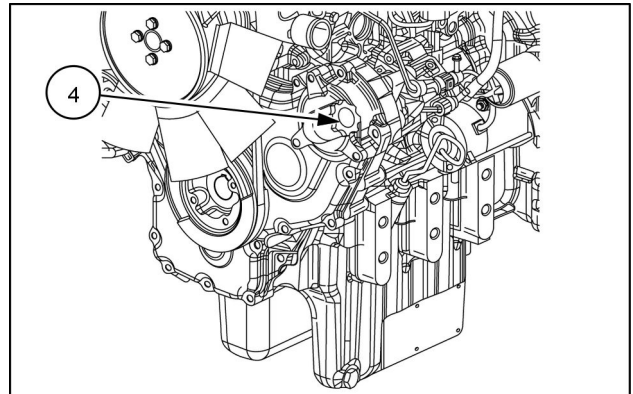

NHIL16CT00449AA 4

Recommended Oils

Ambient Temp (°F)	Recommended Oil
-23.3 – 49 °C (-10 – 120 °F)	CASE IH AKCELA NO. 1™ ENGINE OIL CJ-4 SAE 10W-30
-12 – 49 °C (10 – 120 °F)	CASE IH AKCELA NO. 1™ ENGINE OIL CJ-4 SAE 15W-40
Oil Specification API CJ-4	

<https://www.ebooklibonline.com>

Hello dear friend!

Thank you very much for reading.

Enter the link into your browser.

The full manual is available for immediate download.

<https://www.ebooklibonline.com>