

**FARMALL® 40C**  
**FARMALL® 50C**  
**Tier 4B (final)**  
Compact Tractor

**SERVICE MANUAL**

**Part number 47941906**

2<sup>nd</sup> edition English

March 2016

*Replaces part number 47700459*





## **SERVICE MANUAL**

**Farmall® 40C TIER 4B (FINAL), ROPS  
Farmall® 40C TIER 4B (FINAL), Cab  
Farmall® 50C TIER 4B (FINAL), ROPS  
Farmall® 50C TIER 4B (FINAL), Cab**

# Link Product / Engine

---

<b>Product</b>	<b>Market Product</b>	<b>Engine</b>
Farmall® 40C TIER 4B (FINAL), ROPS	North America	N844L-F-30
Farmall® 40C TIER 4B (FINAL), Cab	North America	N844L-F-30
Farmall® 50C TIER 4B (FINAL), ROPS	North America	N844L-F-34
Farmall® 50C TIER 4B (FINAL), Cab	North America	N844L-F-34

**<https://www.ebooklibonline.com>**

Hello dear friend!

Thank you very much for reading.

Enter the link into your browser.

The full manual is available for immediate download.

**<https://www.ebooklibonline.com>**

# Contents

---

## INTRODUCTION

<b>Engine</b> .....	<b>10</b>
[10.001] Engine and crankcase .....	10.1
[10.202] Air cleaners and lines .....	10.2
[10.206] Fuel filters .....	10.3
[10.304] Engine lubrication system.....	10.4
[10.400] Engine cooling system .....	10.5
[10.501] Exhaust Gas Recirculation (EGR) exhaust treatment.....	10.6
<b>Clutch</b> .....	<b>18</b>
[18.100] Clutch mechanical release control .....	18.1
[18.110] Clutch and components .....	18.2
[18.112] Slip clutch or flywheel damper .....	18.3
<b>Transmission</b> .....	<b>21</b>
[21.114] Mechanical transmission .....	21.1
[21.140] Mechanical transmission internal components.....	21.2
<b>Front axle system</b> .....	<b>25</b>
[25.100] Powered front axle .....	25.1
[25.102] Front bevel gear set and differential .....	25.2
[25.108] Final drive hub, steering knuckles, and shafts .....	25.3
[25.310] Final drives .....	25.4
<b>Rear axle system</b> .....	<b>27</b>
[27.106] Rear bevel gear set and differential .....	27.1
[27.120] Planetary and final drives .....	27.2
<b>Hydrostatic drive</b> .....	<b>29</b>
[29.100] Transmission and steering hydrostatic control .....	29.1
[29.202] Hydrostatic transmission .....	29.2

[29.218] Pump and motor components.....	29.3
<b>Power Take-Off (PTO).....</b>	<b>31</b>
[31.101] Rear mechanical control .....	31.1
[31.104] Rear electro-hydraulic control .....	31.2
[31.110] One-speed rear Power Take-Off (PTO) .....	31.3
[31.120] Central Power Take-Off (PTO) .....	31.4
<b>Brakes and controls .....</b>	<b>33</b>
[33.110] Parking brake or parking lock .....	33.1
[33.120] Mechanical service brakes .....	33.2
<b>Hydraulic systems.....</b>	<b>35</b>
[35.000] Hydraulic systems.....	35.1
[35.104] Fixed displacement pump .....	35.2
[35.114] Three-point hitch control valve .....	35.3
[35.116] Three-point hitch cylinder .....	35.4
[35.204] Remote control valves .....	35.5
[35.300] Reservoir, cooler, and filters.....	35.6
[35.350] Safety and main relief valves .....	35.7
[35.355] Hydraulic hand control .....	35.8
<b>Hitches, drawbars, and implement couplings.....</b>	<b>37</b>
[37.108] Rear three-point hitch external controls.....	37.1
[37.110] Rear three-point hitch .....	37.2
<b>Steering.....</b>	<b>41</b>
[41.101] Steering control .....	41.1
[41.106] Tie rods.....	41.2
[41.200] Hydraulic control components.....	41.3
[41.216] Cylinders .....	41.4
<b>Wheels .....</b>	<b>44</b>

[44.511] Front wheels .....	44.1
[44.520] Rear wheels .....	44.2
<b>Cab climate control .....</b>	<b>50</b>
[50.100] Heating .....	50.1
[50.104] Ventilation .....	50.2
[50.200] Air conditioning .....	50.3
<b>Electrical systems .....</b>	<b>55</b>
[55.000] Electrical system .....	55.1
[55.011] Fuel tank system .....	55.2
[55.031] Parking brake electrical system .....	55.3
[55.048] Rear Power Take-Off (PTO) control system .....	55.4
[55.100] Harnesses and connectors .....	55.5
[55.201] Engine starting system .....	55.6
[55.202] Cold start aid .....	55.7
[55.302] Battery .....	55.8
[55.404] External lighting .....	55.9
[55.405] External lighting switches and relays .....	55.10
[55.408] Warning indicators, alarms, and instruments .....	55.11
[55.513] Cab transmission controls .....	55.12
[55.525] Cab engine controls .....	55.13
[55.610] Ground speed control .....	55.14
[55.640] Electronic modules .....	55.15
[55.989] Exhaust Gas Recirculation (EGR) electrical system .....	55.16
[55.DTC] FAULT CODES .....	55.17
<b>Platform, cab, bodywork, and decals .....</b>	<b>90</b>
[90.100] Engine hood and panels .....	90.1
[90.114] Operator protections .....	90.2
[90.116] Fenders and guards .....	90.3

[90.120] Mechanically-adjusted operator seat..... 90.4

[90.150] Cab..... 90.5

[90.151] Cab interior..... 90.6

[90.154] Cab doors and hatches ..... 90.7

[90.156] Cab glazing ..... 90.8



# INTRODUCTION

---

## Safety rules

Farmall® 40C	NA
Farmall® 50C	NA

### Personal safety





This is the safety alert symbol. It is used to alert you to potential personal injury hazards. Obey all safety messages that follow this symbol to avoid possible death or injury.

Throughout this manual you will find the signal words DANGER, WARNING, and CAUTION followed by special instructions. These precautions are intended for the personal safety of you and those working with you.

Read and understand all the safety messages in this manual before you operate or service the machine.

 DANGER indicates a hazardous situation that, if not avoided, will result in death or serious injury.

 WARNING indicates a hazardous situation that, if not avoided, could result in death or serious injury.

 CAUTION indicates a hazardous situation that, if not avoided, could result in minor or moderate injury.

### **FAILURE TO FOLLOW DANGER, WARNING, AND CAUTION MESSAGES COULD RESULT IN DEATH OR SERIOUS INJURY.**

### Machine safety

**NOTICE:** Notice indicates a situation that, if not avoided, could result in machine or property damage.

Throughout this manual you will find the signal word Notice followed by special instructions to prevent machine or property damage. The word Notice is used to address practices not related to personal safety.

### Information

**NOTE:** Note indicates additional information that clarifies steps, procedures, or other information in this manual.

Throughout this manual you will find the word Note followed by additional information about a step, procedure, or other information in the manual. The word Note is not intended to address personal safety or property damage.

---

## Safety rules Service precautionary statements climate control

### SERVICE PRECAUTIONARY STATEMENTS

#### Leak Testing

Recharging an air conditioning system that leaks simply allows more refrigerant to escape into the atmosphere and ultimately leaves the system non-functioning and in need of additional charging.

Therefore, the proper service procedure is to locate and fix any leaks before putting any more refrigerant into the system.

If a large amount of refrigerant has leaked out, the system pressure will be too low to identify all but the largest leaks. In this case, partially recharge the system with no more than one pound of refrigerant to check for leaks.

**NOTICE:** • *Any refrigerant introduced into the system for the purpose of finding leaks must also be recovered without releasing it into the atmosphere.*

• *Always use the same type of refrigerant for checking leaks as was originally installed into the AC system by the manufacturer.*

• *Never use compressed air to detect system leaks. The introduction of air into the system may create a fire or explosion hazard, may overload the desiccant with moisture, and could contaminate the system with dirt and improper oil.*

All automotive type air conditioning systems leak to some extent. When servicing them it is important that leakage be minimized. Much of the normal leakage comes from the slow seepage of refrigerant through the flexible hoses. Other common sources of leaks are at joints between the flexible hose and metal tubing or at threaded hose connections. These are usually much larger leaks than the natural seepage through the walls of the hose and are almost always repairable.

Research by the EPA has found that leak detection can be difficult, but existing halogen leak detection systems are adequate for the major task of finding and repairing leaks causing complaints. Dye stains are not very satisfactory for finding small leaks.

Newer electronic leak detectors may offer even better leak detection capabilities. However, no single method can find every leak. Electronic leak detectors may not detect leaks of all refrigerants. For example, older units designed to detect R12 may not detect **R134A**. Be sure that the leak detector you use is state-of-the-art and that it is designed to detect the refrigerant in the system you are servicing.

Service professionals must be extremely diligent in their work to correct all possible leaks. Diligence is essential to ensure that no small, difficult-to-find leaks go undetected.

Before leaving a job, make one last leak check. Catching a leak just after service will save an inconvenient and expensive return visit.

#### Refilling

Refill the air conditioning system using the weight method. The lubricants used in R134a tend to layer onto the walls of the refrigeration system. This layering obscures the view through the sight glass. Visual methods of refilling R134a systems will result in improper system charging. For this reason, we do not recommend the old practice of topping off a partially discharged air conditioning system using the sight glass. The Farmall 40C/50C cab tractors use **700 g (25 oz)** of **R134A** refrigerant.

---

## CONTAMINANTS

### General

No mobile air conditioning system can operate for long without picking up some contaminants in the refrigerant. The flexible hoses, for example, allow moisture and air to migrate into the refrigerant from the outside atmosphere. Moisture and non-condensable gases (air) are the most common contaminants found in mobile air conditioning systems.

**NOTICE:** *Contaminating R134A with R12 or CFC will lead to copper plating of steel components and major compressor failure.*

Lubricant and refrigerant that remain in service equipment can be contaminants. When you recover a refrigerant, you also will capture a certain amount of lubricant in the extraction or recovery equipment. The equipment will drain the lubricant in a catch bottle or reservoir for measurement and proper final disposal.

Never use a lubricant that has come out of an air conditioning system. Reusing this oil will result in contamination of the air conditioning system with refrigerant, moisture and air from the old oil. Instead, refill the air conditioning system using fresh oil in the same amount as that removed during service. Dispose of the used oils in a manner that complies with federal, state and local disposal requirements.

To avoid contamination between systems using dissimilar refrigerants, the extraction and recycling equipment **MUST** be dedicated to a single refrigerant.

### Preventing Mixing of Service Equipment

To help avoid the mistake of charging a system with an incorrect, incompatible refrigerant, the compressor fittings are different for refrigerants R12 and **R134A**. Systems using **R134A** have quick couple service connections, while R12 systems use screw threads. This prevents the use of the same tools for different refrigerants, thereby helping to avoid the mixing of refrigerants in service equipment.

If refrigerants become mixed, the thermodynamic and chemical characteristics will change. This change results in excessive pressure and poor lubrication and leads to failure of the compressor, desiccant (drier) and other system components.

Ultimately, system failure and an expensive repair bill will result if refrigerants become mixed in a single set of service equipment.

## REFRIGERANT EXTRACTION AND RECYCLING EQUIPMENT

Both extraction and recycling equipment are in use and available to service technicians. Both types of equipment will remove the refrigerant from an air conditioning system. However, extraction equipment only pulls the refrigerant from the air conditioning system and stores it in an appropriate container. Extraction equipment does not clean the refrigerant. Its only purpose is to recover the refrigerant from an air conditioning system prior to disassembling and servicing it.

Always recycle or reclaim recovered refrigerant before putting it back into an air conditioning system. During service operations involving a partial recharge, or while the air conditioning system is in use, refrigerant can pick up moisture, lubricants, microscopic metal chips, and other potential contaminants. In many cases the contaminants contribute to or are the primary cause of the system failure. Putting used, unclean refrigerant back into an air conditioning system may result in poor system performance.

**NOTICE:** *Reuse of unrecycled, unreclaimed refrigerant will void the warranty.*

Equipment that removes refrigerant from a mobile air conditioning system (recovery equipment) may allow you to put the used refrigerant back in the system without first cleaning it to minimize performance. You may also use such conditioning systems. Non-mobile air conditioning systems use refrigerants and contain contaminants that are different from those in mobile air conditioning systems. Recovery equipment may therefore allow the mixing of different types of refrigerants or introduce contaminants that may not be removable by recycling equipment available in the service shop.

If you want to remove, clean and reuse **R134A** refrigerant, you must use a machine that both extracts and recycles refrigerant from mobile air conditioning systems. Dedicate that machine to R134a only.

Recycling equipment meeting SAE standards J1990 and J2210 is designed to extract and recycle refrigerants that have been in mobile air conditioning systems only. **R134A** refrigerant that also is used in non-mobile systems may introduce contaminants to the refrigerant that equipment meeting SAE J1990 and J2210 cannot remove. This equipment is not intended for use on non-mobile systems.

### Using Extraction Equipment

Extraction equipment is relatively small and easily portable. It is best used if a shop must service vehicles, such as agricultural or off-highway equipment, that cannot easily be brought into the shop. It is also convenient for shops that must deal with a variety of different refrigerant types and exchange recovered refrigerant at some central location.

Always use extraction equipment on those refrigerants for which it was designed. The lubricants, hoses, and seals in this equipment have been designed to work with only one refrigerant.

To help avoid a mix-up of service equipment and refrigerants, equipment hoses designed for use with each refrigerant are easily identifiable. New service hoses used with **R134A** must have a black stripe along the hose length and carry the designation "SAE J2196/ **R134A**" (hoses labeled "SAE J 2196" and lacking the black stripe were used for R12.)

If you use extraction equipment and send your recovered refrigerant to a reclamation facility, reclaimed refrigerant you purchase must meet the Air Conditioning and Refrigeration Institute standards of purity (ARI Standard 700-88). This will ensure that the refrigerant you are using not only meets the purity requirements of SAE J1991 (for R12) OR J2099 (for **R134A**), but also that it does not contain incompatible lubricants or other contaminants from non-automotive air conditioning systems.

### Using Recycling Equipment

Recycling equipment extracts and removes common contaminants from refrigerants. Recycling equipment designed and certified to meet SAE standards can make refrigerant recovery from mobile air conditioning systems suitable for reuse in automotive air conditioning systems. Like extraction equipment, SAE standards require that each piece of recycling equipment be dedicated to a single refrigerant.

**NOTICE:** Only equipment capable of recovering and cleaning **R134A** to meet SAE J2099 purity levels carries a label with the phrase "Design certified by Underwriters" Laboratories, Inc. for compliance with SAE J2099.

The Underwriters' Laboratories label must be specific that the equipment is "design certified" for the SAE J2099 standard. If not, it certifies only that the machine is free of reasonable shock or other electrical hazards to the user.

### Recycling vs. Reclaiming

Recycled refrigerant has been recovered from a mobile air conditioning system and is cleaned by the same shop that recovered it to meet J2099 for **R134A**. The equipment designed to recycle refrigerant in the shop environment removes only contaminants picked up during the operation of a mobile air conditioning system.

Refrigerant that is either properly recycled or reclaimed is adequate for use in mobile air conditioning systems.



# **SERVICE MANUAL**

## **Engine**

**Farmall® 40C TIER 4B (FINAL), ROPS  
Farmall® 40C TIER 4B (FINAL), Cab  
Farmall® 50C TIER 4B (FINAL), ROPS  
Farmall® 50C TIER 4B (FINAL), Cab**

## Engine - Remove

Farmall® 40C TIER 4B (FINAL), ROPS	NA
Farmall® 50C TIER 4B (FINAL), ROPS	NA

1. Chock all four wheels so that the tractor cannot move.
2. Disconnect negative (-) battery cable **(1)**.

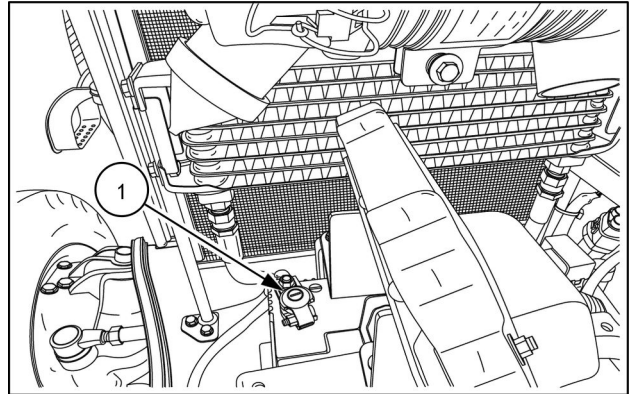

NHIL13CT01033AA 1

3. Disconnect headlight wire harness.
4. See **Hood - Remove (90.100)**.
5. Disconnect the main and engine wire harnesses.
6. Turn off fuel supply at the filter **(1)**, and then disconnect fuel hose.

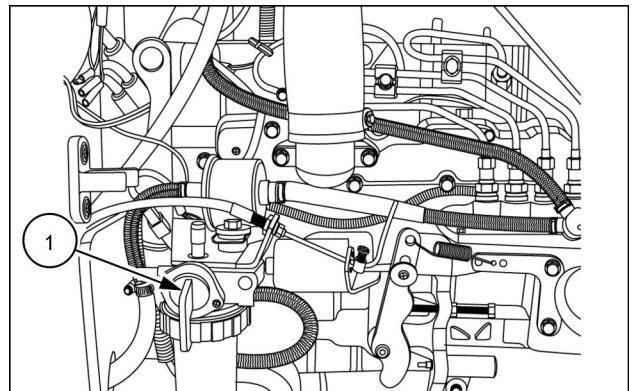

93102239 2

7. Position a drain pan to collect drain oil and unfasten clamps **(1)**.
8. Disassemble suction tube assembly **(2)**.

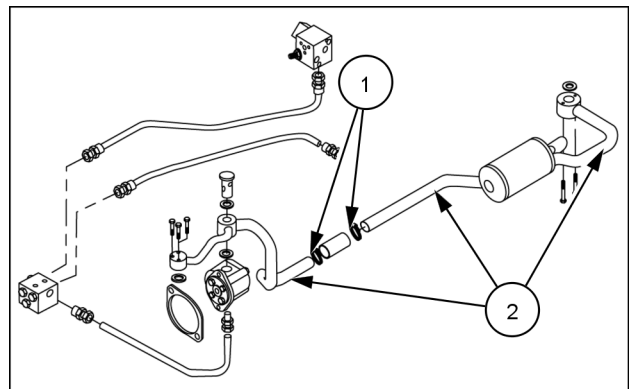

93102240 3

9. Remove the knobs **(2)** on both rear cover halves **(1)** and remove.

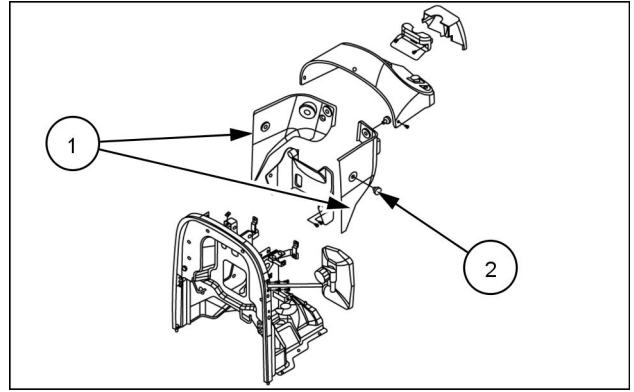

93102241 4

10. Remove the mat **(1)**.  
11. Remove the M8 nuts and bolts and remove cover **(2)**.

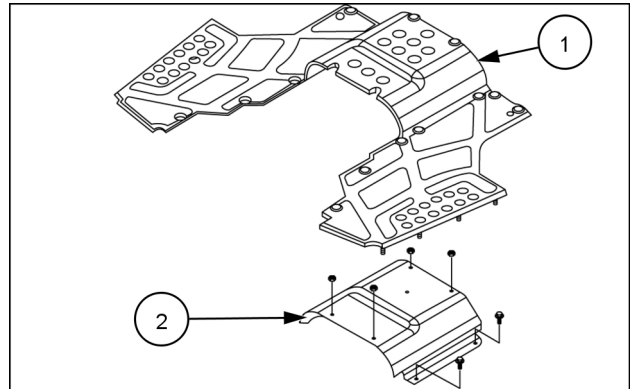

93102242 5

12. Remove the bolts **(2)** and remove the pedals **(1)**.

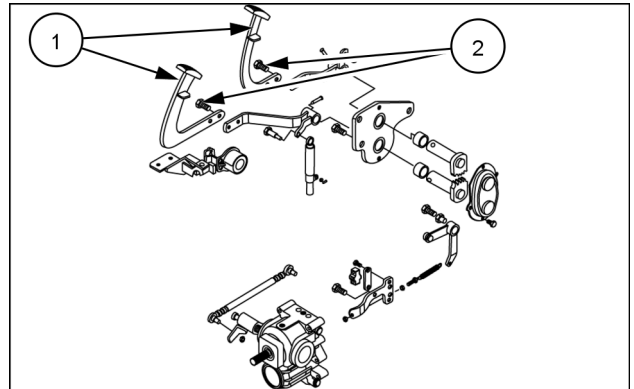

93102243 6

13. Remove the seven M8 and one M24 bolts **(3)**.  
14. Remove right-hand step **(1)** and left-hand step **(2)**.

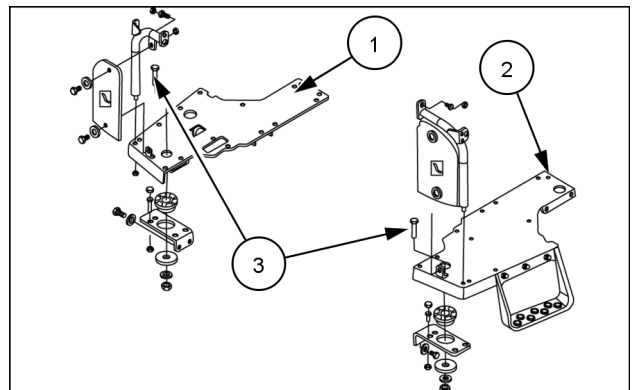

93102244 7

15. Disconnect the front high pressure tube (1).

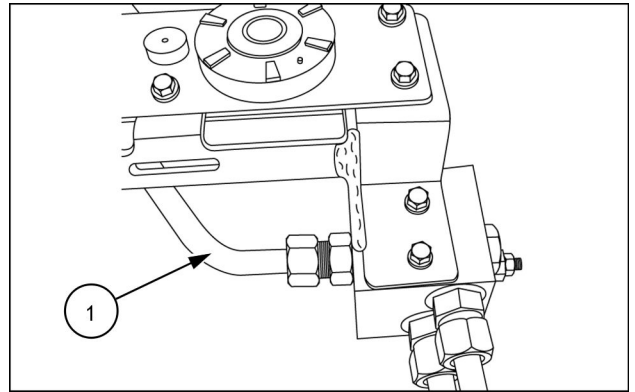

93102245 8

16. Disconnect steering hoses (2) and tubes (1).

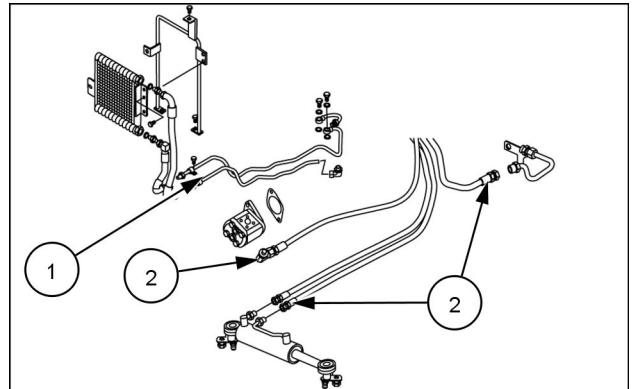

93102246 9

17. Disconnect brake the rod (1), Hydrostatic Transmission (HST) or gear transmission.

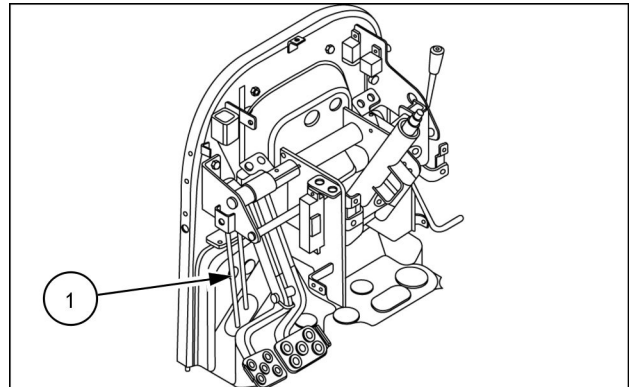

93102247 10

18. Disconnect brake rod (2) on the right-hand side and clutch rod on the left-hand side; gear transmission only.

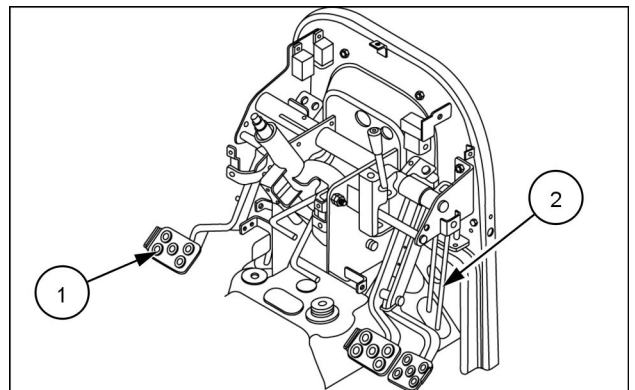

93102248 11

(1) Clutch pedal

1. Disassemble the brake rods linkage **(1)** and **(2)** as shown.

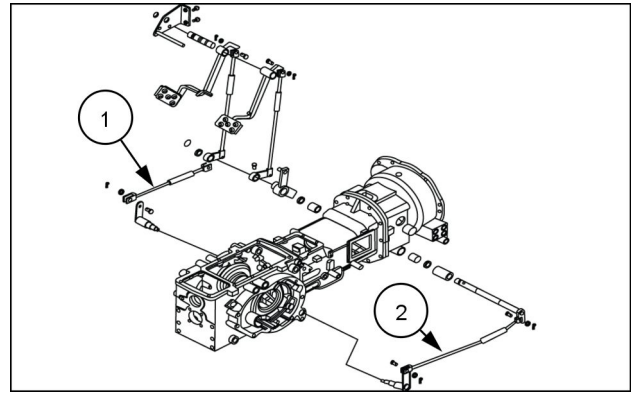

93102250 12

2. Remove bolts **(2)** securing the frame **(1)** to the fire wall, and remove frame.

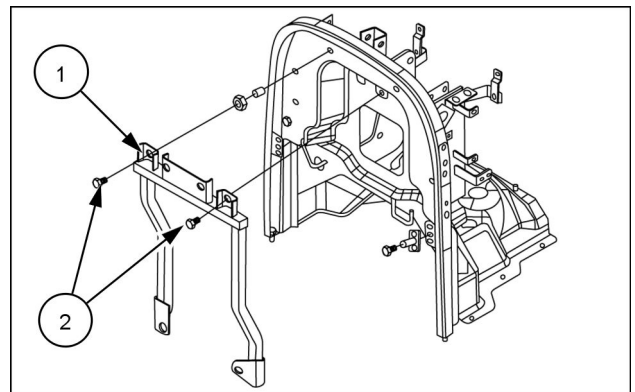

93102251 13

3. Remove the fire wall **(1)** with the aid of a hoist.

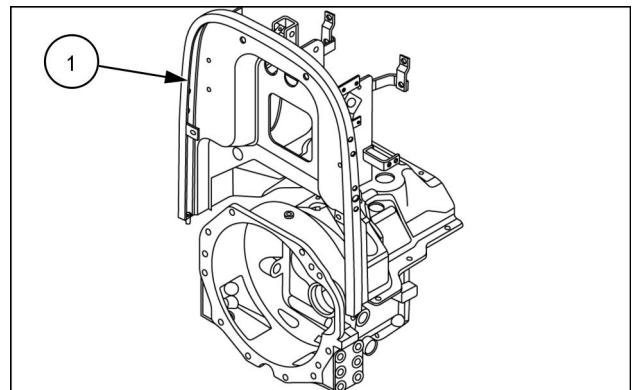

93102252 14

4. Disconnect and remove the oil cooler **(1)** and related parts, as shown in figure 15.

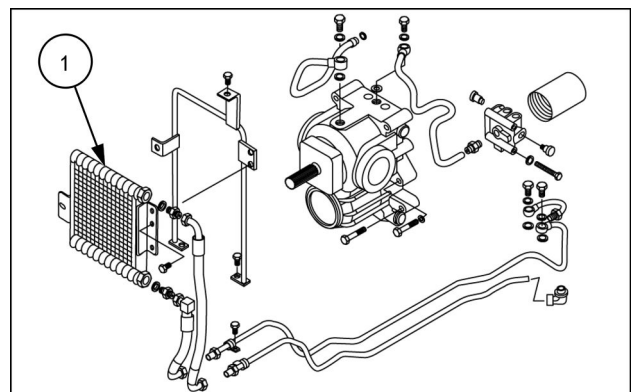

93102253 15

### Secure the tractor for separation:

1. Attach a chain sling (2) to the two hoist eyes on the engine: One located on the left-hand side above the exhaust manifold, the other on the right-hand side to the rear of the injector rail.
2. Attach a suitable hoist to the chain sling.
3. Roll a floor jack (1) under the tractor from the rear of the tractor, and place under the clutch housing. Raise the jack enough to support the drive train.

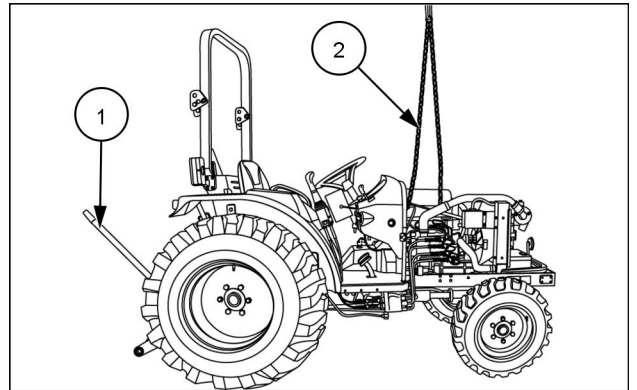

93105782 16

4. Remove eight M12 bolts (2) holding the engine (1) and transmission (3), while checking front wheel drive shaft for separation from the transmission.

**NOTE:** The hoist and/or the floor jack may need to be raised or lowered to allow the separation of the engine from the clutch housing.

5. Carefully roll the drive train away from the engine, using the floor jack for support.

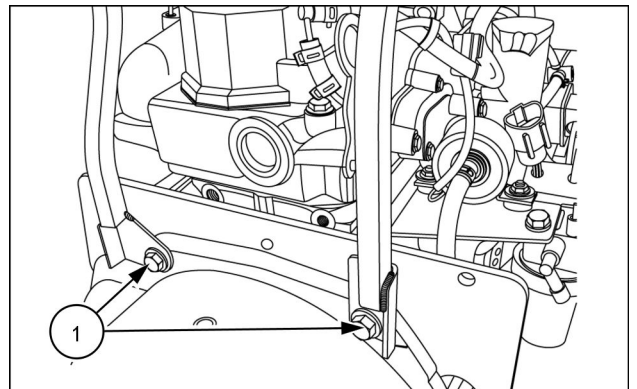

93102254 17

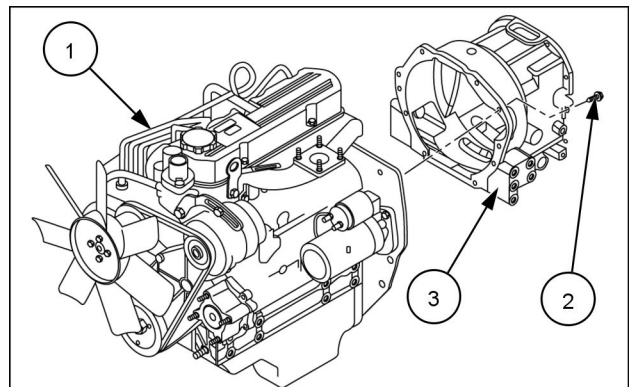

93105783 18

## Engine - Remove

Farmall® 40C TIER 4B (FINAL), Cab	NA
Farmall® 50C TIER 4B (FINAL), Cab	NA

**NOTICE:** Prior to engine removal, the air conditioning system must be evacuated. ( See **Air conditioning - Service instruction - Evacuating the Refrigerant (50.200)**, and the A/C lines must be disconnected.

1. Chock all four wheels so that the tractor cannot move.
2. Disconnect the negative (-) battery cable (1).

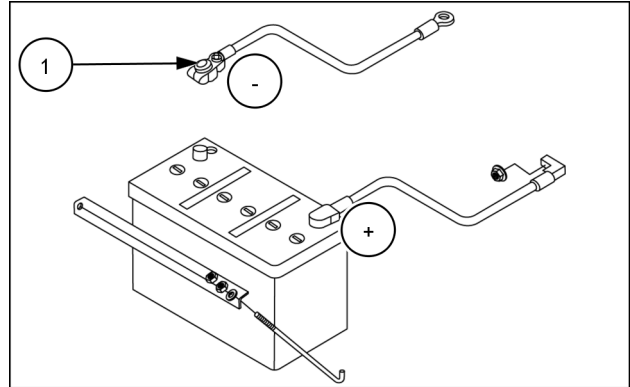

93102237 1

3. Disconnect the headlight wire harness.
4. See **Hood - Remove (90.100)**.
5. Disconnect the main and engine wire harnesses.
6. Turn off fuel supply at the filter (1), and then disconnect fuel hose.

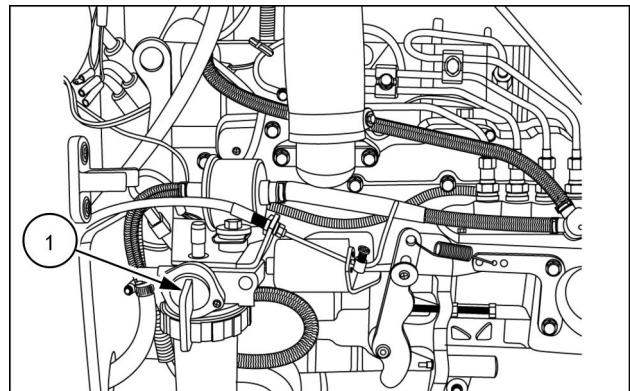

93102239 2

7. Position a drain pan to collect drain oil and unfasten clamps (1).
8. Disassemble the suction tube assembly (2).

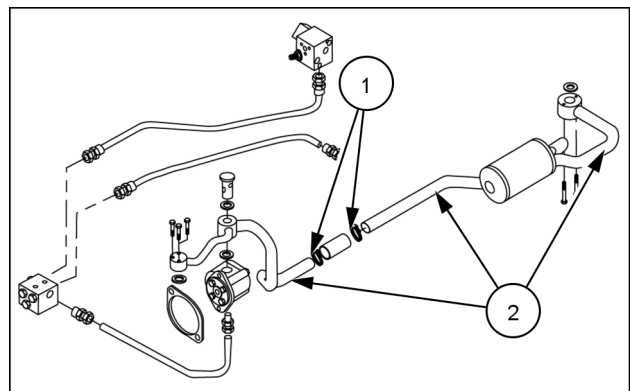

93102240 3

9. Remove the four knobs **(2)** on both rear cover halves **(1)** and remove.
10. Remove the four screws **(3)**, and remove the lower panel **(4)**.

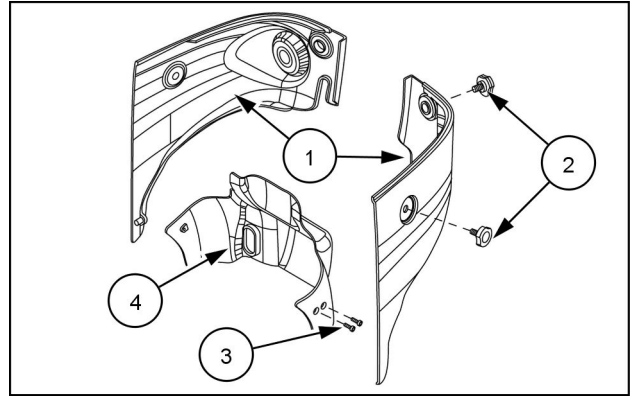

NHIL16CT00122AA 4

11. Remove mat **(1)**.
12. Unscrew the M8 nuts and bolts and remove cover **(2)**.

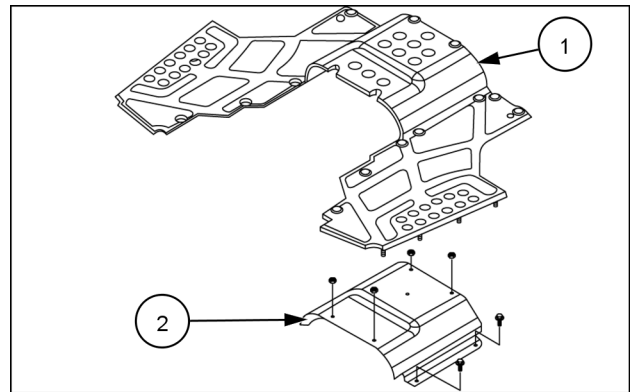

93102242 5

13. Unfasten bolts **(2)** and remove pedals **(1)**.

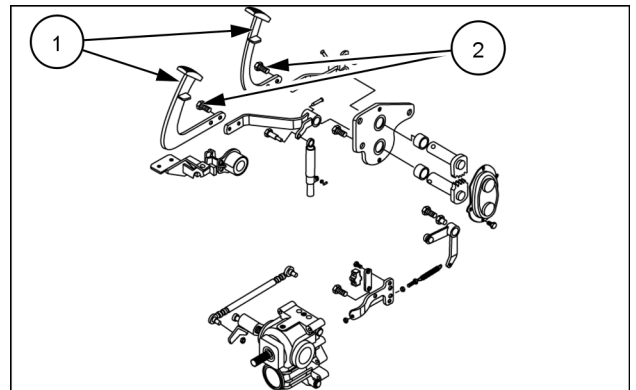

93102243 6

14. Remove the seven M8 and one M24 bolts **(3)**.
15. Remove the right-hand step **(1)** and left-hand step **(2)**.

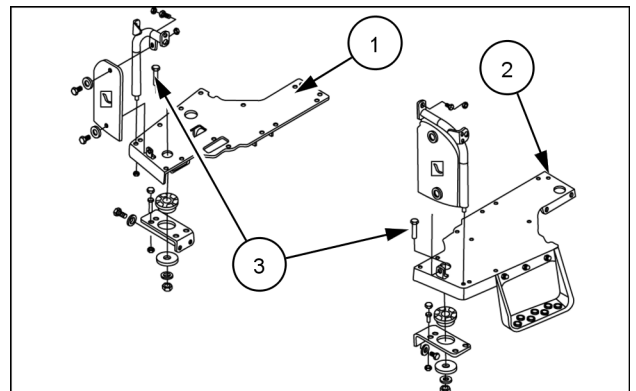

93102244 7

16. Disconnect the front high pressure tube **(1)**.

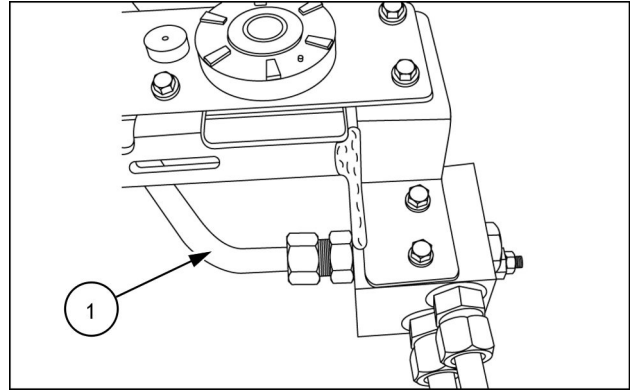

93102245 8

17. Disconnect the steering hoses **(1)** and tubes **(2)**.

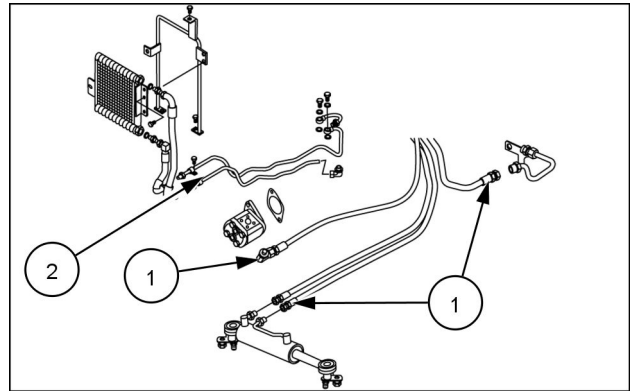

93102246 9

18. Disconnect the brake rod **(1)**; Hydrostatic or gear transmission.

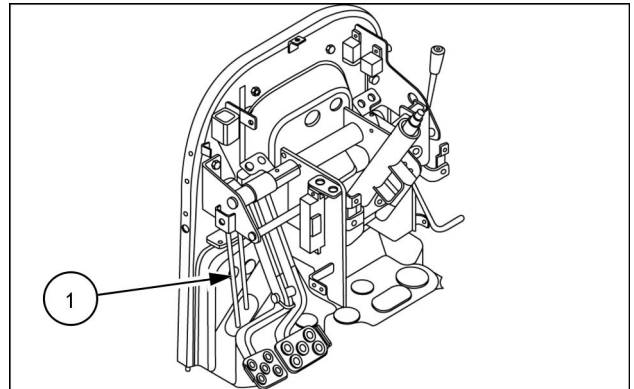

93102247 10

19. Disconnect the brake rod **(1)** on the right-hand side and clutch rod on the left-hand side; gear transmission only.

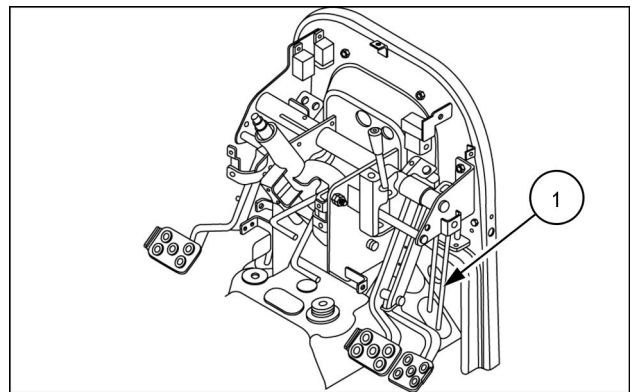

93102248 11

20. Unfasten bolts (2) securing the frame (1) to the fire-wall.
21. Remove the frame (2).

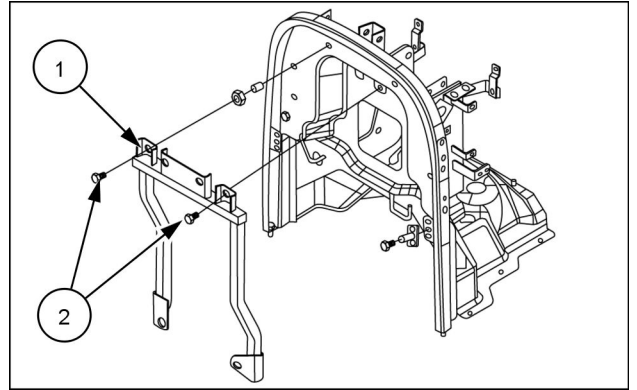

93102251 12

22. Use a hoist to carefully remove the firewall (1).

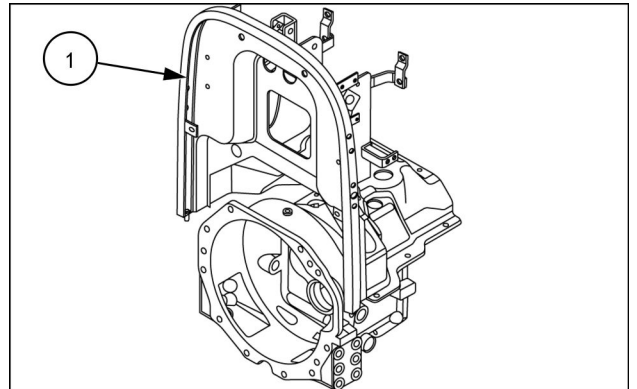

93102252 13

23. Disconnect and remove the oil cooler (1) and related parts, as shown in figure 14.

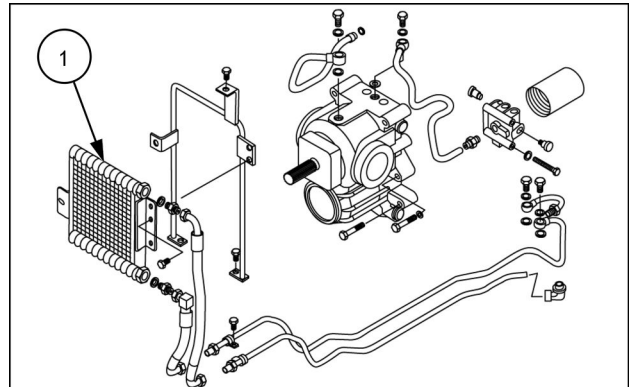

93102253 14

24. Attach a chain sling (2) to the two hoist eyes on the engine.

**NOTE:** One is located on the left-hand side above the exhaust manifold, the other on the right-hand side to the rear of the injector rail.

25. Attach a suitable hoist to the chain sling and secure the tractor for separation.
26. Roll a floor jack (1) under the tractor from the rear of the tractor, and place under the clutch housing. Raise the jack enough to support the drive train.

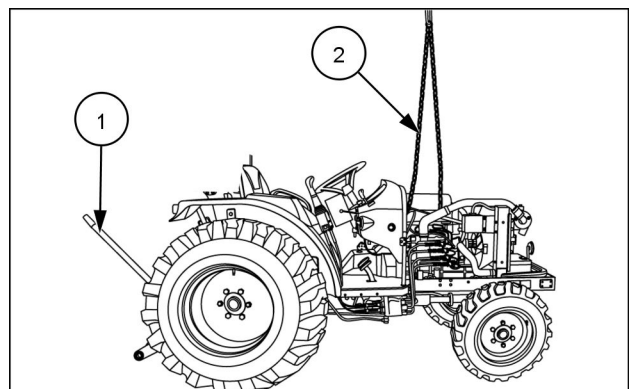

93105782 15

27. Unfasten eight M12 bolts (1) holding the engine (3) and transmission (2), while checking front wheel drive shaft for separation from the transmission.

**NOTE:** The hoist and/or the floor jack may need to be raised or lowered to allow the separation of the engine from the clutch housing.

28. Use the floor jack for support and carefully roll the drive train away from the engine.

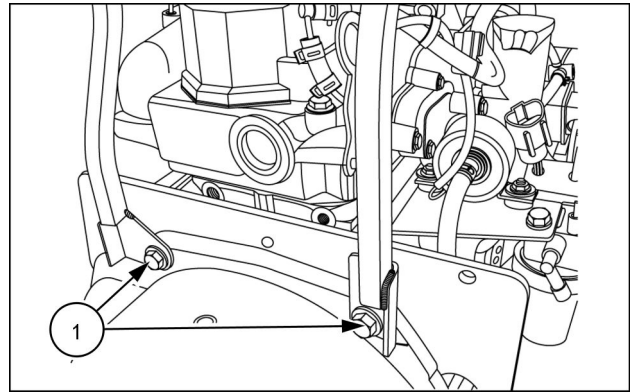

93102254 16

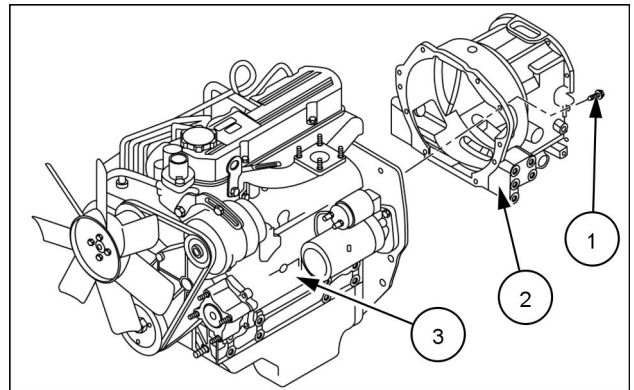

93105783 17

## Engine - Install

Farmall® 40C TIER 4B (FINAL), ROPS	NA
Farmall® 50C TIER 4B (FINAL), ROPS	NA

1. Roll a floor jack (1) under the tractor from the rear of the tractor, and place under the clutch housing. Raise the jack enough to support the drive train.
2. Attach a chain sling (2) to the two hoist eyes on the engine, and position the engine into place on the tractor.

**NOTE:** The hoist and/or the floor jack may need to be raised or lowered to allow the engine and clutch housing to mate.

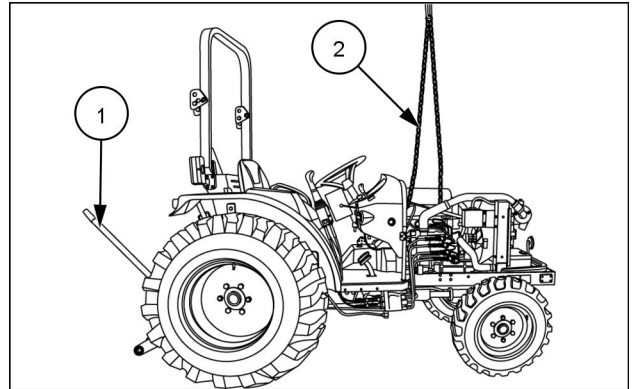

93105782 1

3. Install eight M12 bolts (1) to secure the engine (3) to the transmission (2).

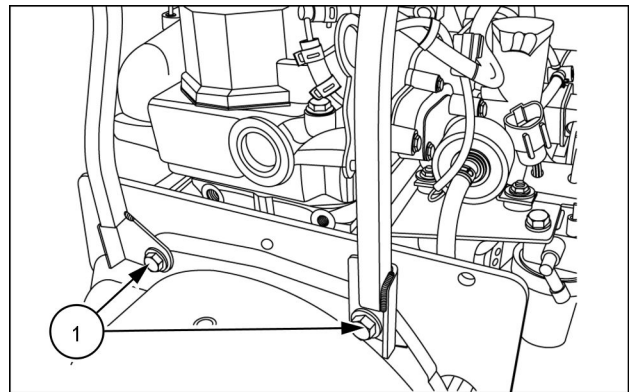

93102254 2

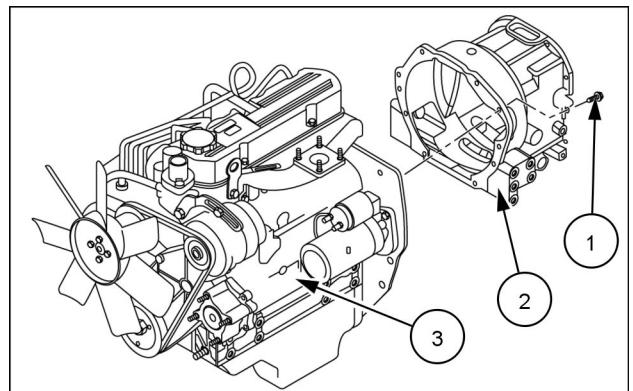

93105783 3

4. Install and connect the oil cooler (1) and related parts, as shown.

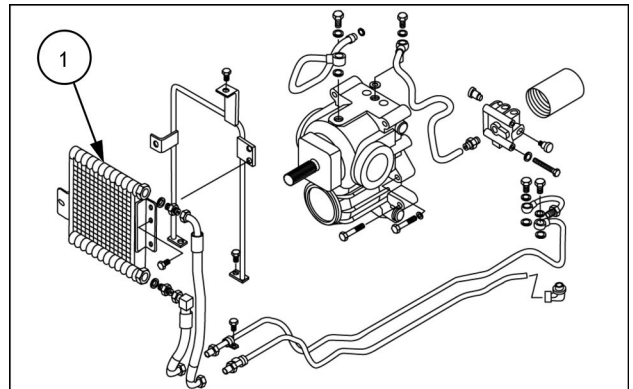

93102253 4

5. Use a hoist to carefully install the firewall (1).

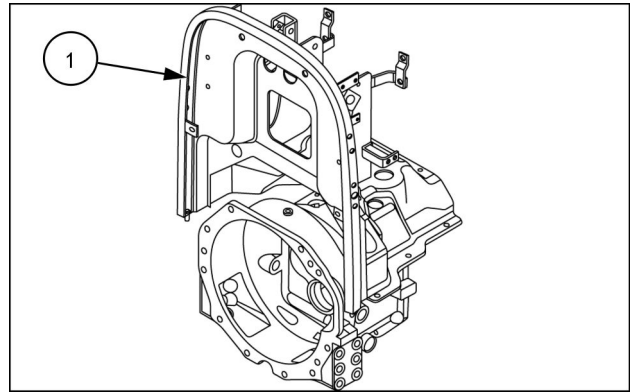

93102252 5

6. Position the frame (2) into place.  
7. Install the bolts (2) to secure the frame (1) to the firewall.

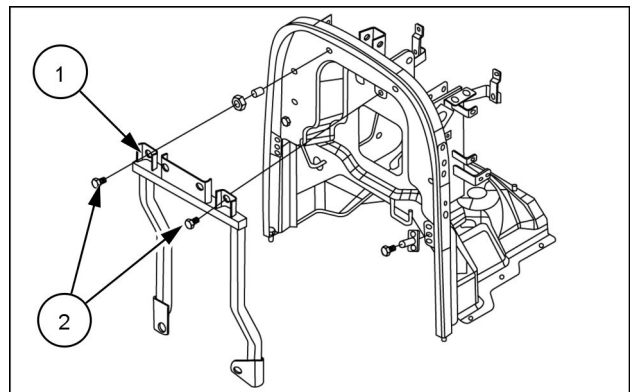

93102251 6

8. Connect the brake rod (1) on the right-hand side, and clutch rod to the left-hand side.

**NOTE:** Gear transmission only.

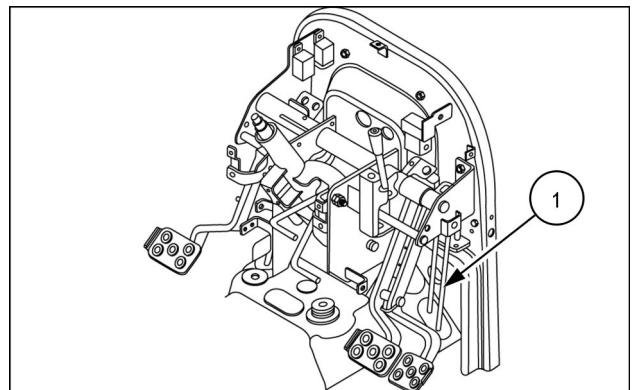

93102248 7

9. Connect the brake rod (1).

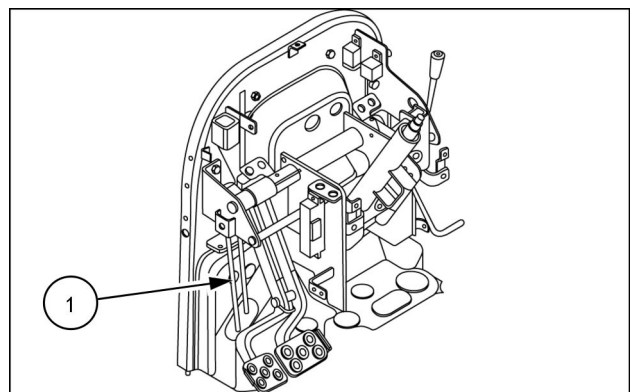

93102247 8

10. Connect the steering hoses (1) and tubes (2).

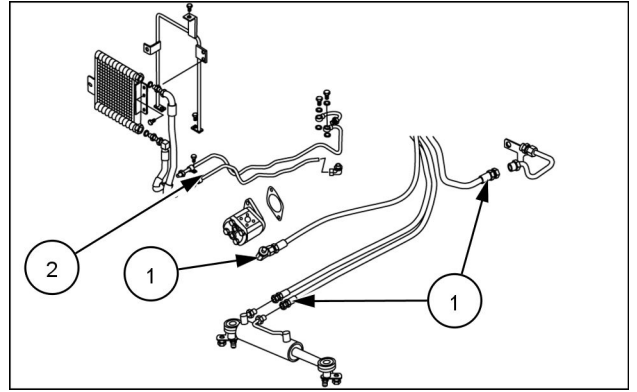

93102246 9

11. Connect the front high pressure tube (1).

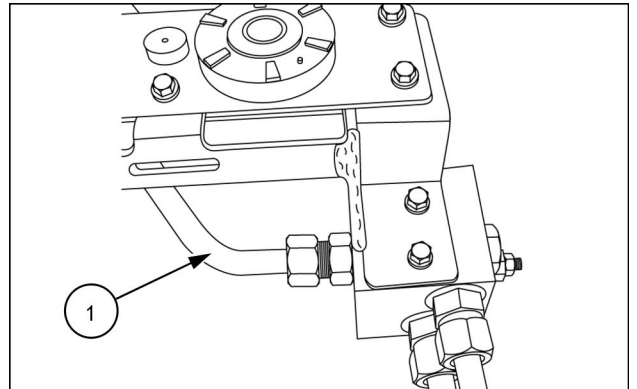

93102245 10

12. Position the right-hand step (1) and left-hand step (2) into place.  
13. Install seven M8 bolts and one M24 bolt (3) to secure the steps.

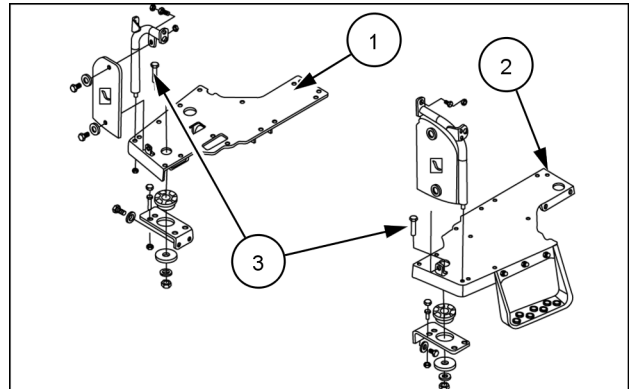

93102244 11

14. Install the pedals (1) and secure with bolts (2).

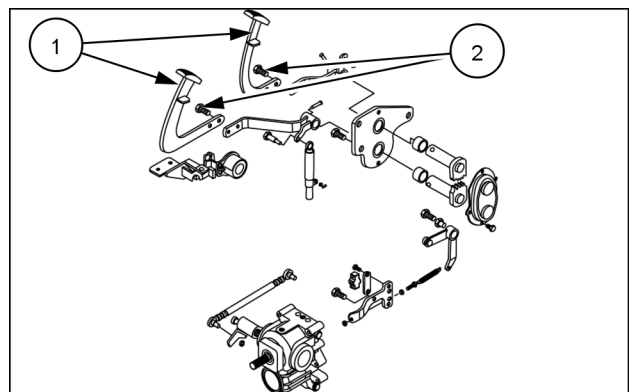

93102243 12

15. Install the cover **(2)** and secure with the M8 nuts and bolts.
16. Install the mat **(1)**.

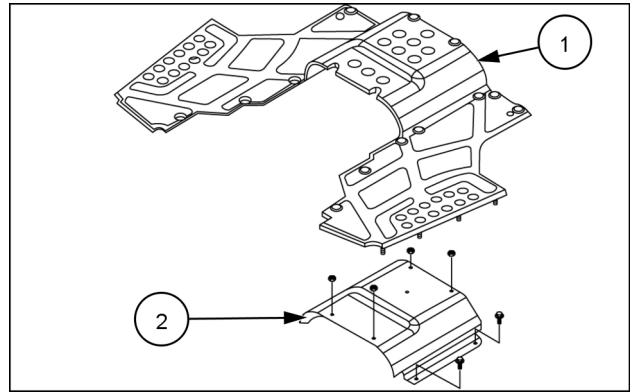

93102242 13

17. Install the rear cover halves **(1)** and secure with the knobs **(2)**.

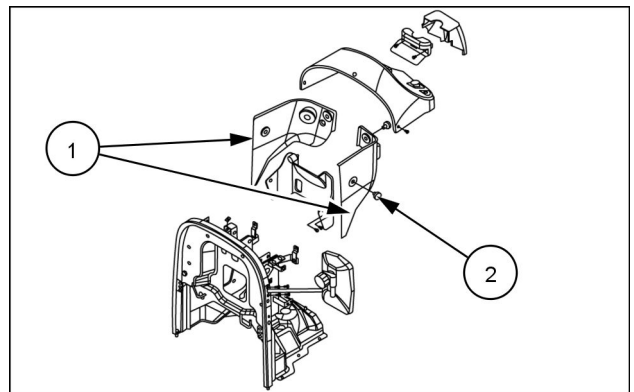

93102241 14

18. Assemble the suction tube assembly **(2)** and secure with the clamps **(1)**.

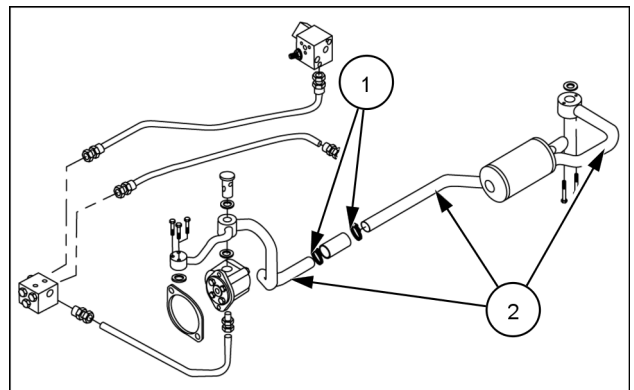

93102240 15

19. Connect the fuel hose, and then turn on the fuel supply at the filter **(1)**.
20. Connect the main and engine wire harnesses.

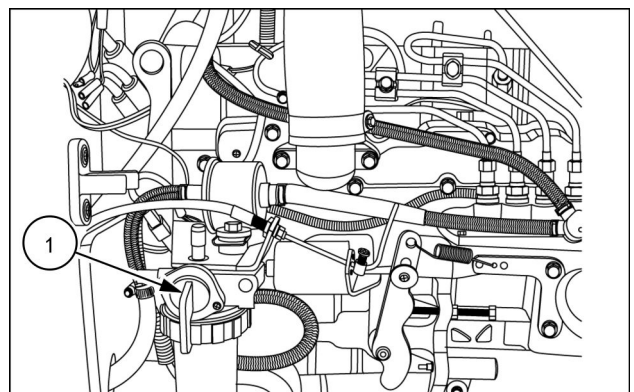

93102239 16

21. See **Hood - Install (90.100)**.
22. Connect the headlight wire harness.

23. Connect the negative (-) battery cable **(1)**.
24. Remove the wheel chocks.

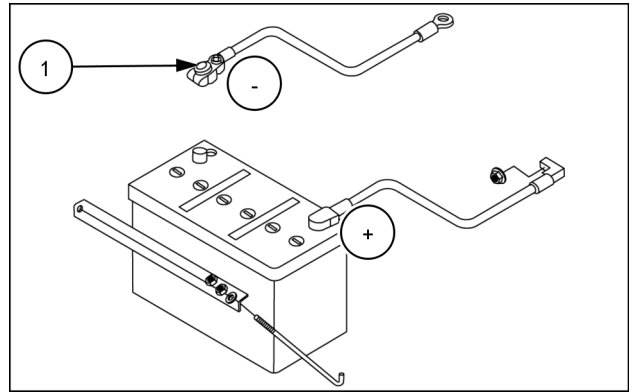

93102237 17

## Engine - Install

Farmall® 40C TIER 4B (FINAL), Cab	NA
Farmall® 50C TIER 4B (FINAL), Cab	NA

1. Roll a floor jack **(1)** under the tractor from the rear of the tractor, and place under the clutch housing. Raise the jack enough to support the drive train.
2. Attach a chain sling **(2)** to the two hoist eyes on the engine, and position the engine into place on the tractor.

**NOTE:** The hoist and/or the floor jack may need to be raised or lowered to allow the engine and clutch housing to mate.

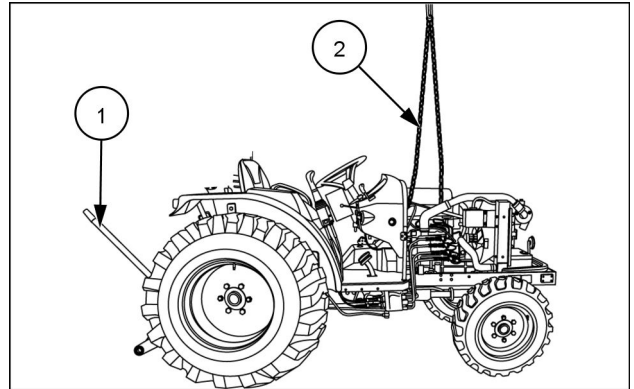

93105782 1

3. Install eight M12 bolts **(1)** to secure the engine **(3)** to the transmission **(2)**.

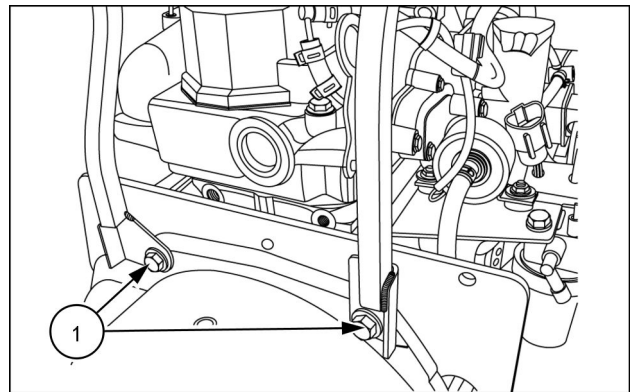

93102254 2

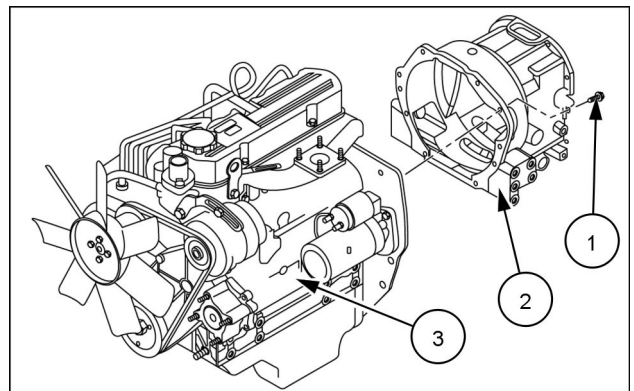

93105783 3

4. Install and connect the oil cooler **(1)** and related parts, as shown.

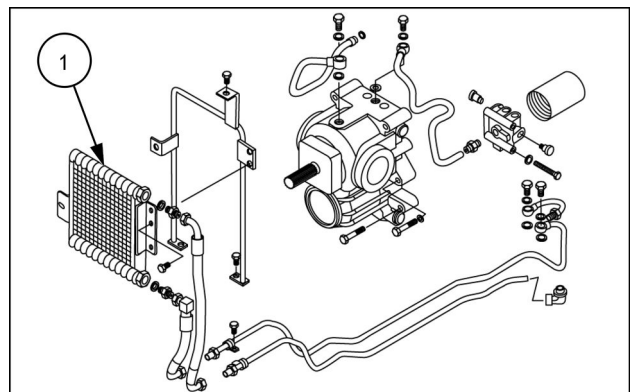

93102253 4

5. Use a hoist to carefully install the firewall (1).

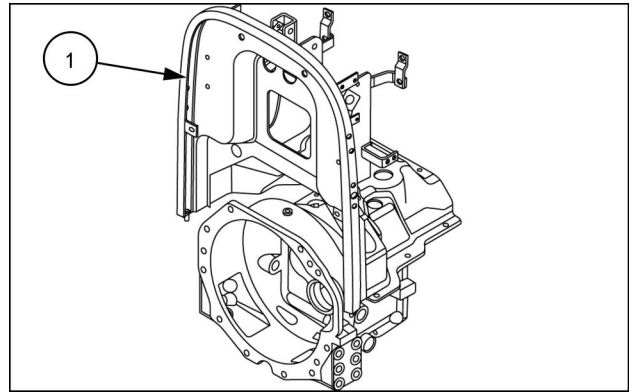

93102252 5

6. Position the frame (2) into place.  
7. Install the bolts (2) to secure the frame (1) to the firewall.

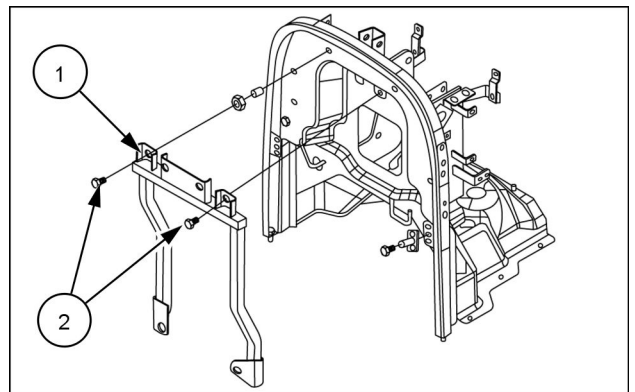

93102251 6

8. Connect the brake rod (1) on the right-hand side, and clutch rod to the left-hand side.

**NOTE:** Gear transmission only.

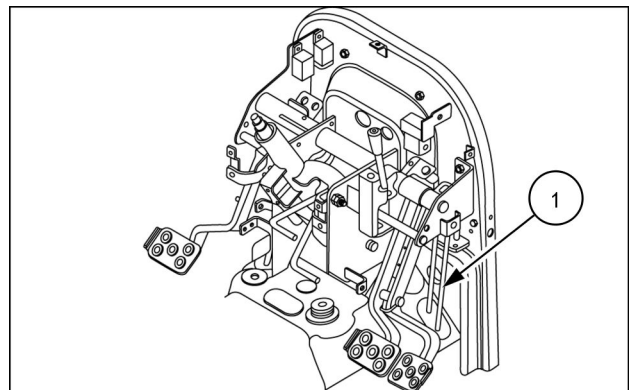

93102248 7

9. Connect the brake rod (1).

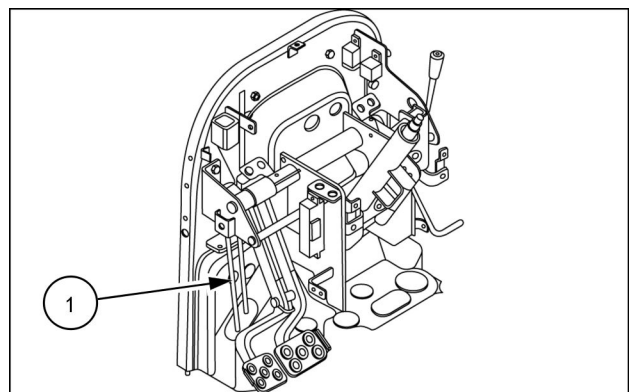

93102247 8

10. Connect the steering hoses (1) and tubes (2).

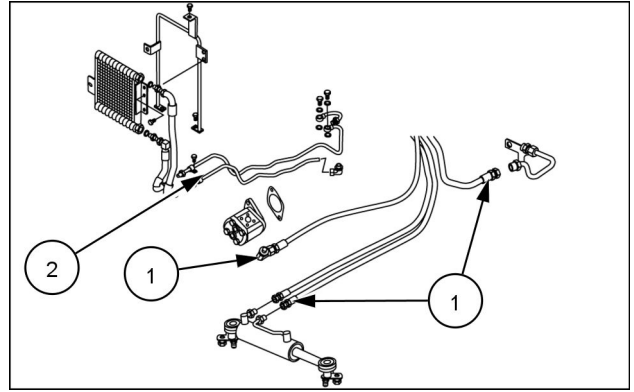

93102246 9

11. Connect the front high pressure tube (1).

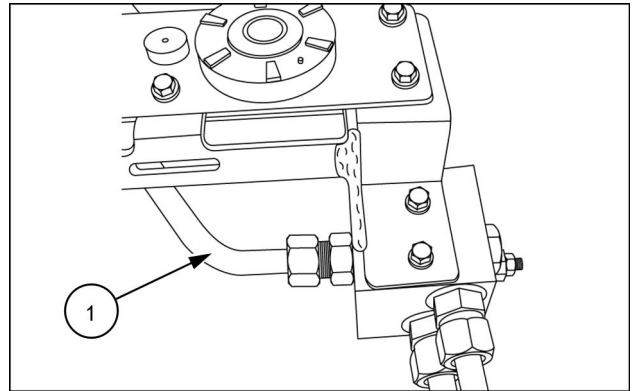

93102245 10

12. Position the right-hand step (1) and left-hand step (2) into place.

13. Install seven M8 bolts and one M24 bolt (3) to secure the steps.

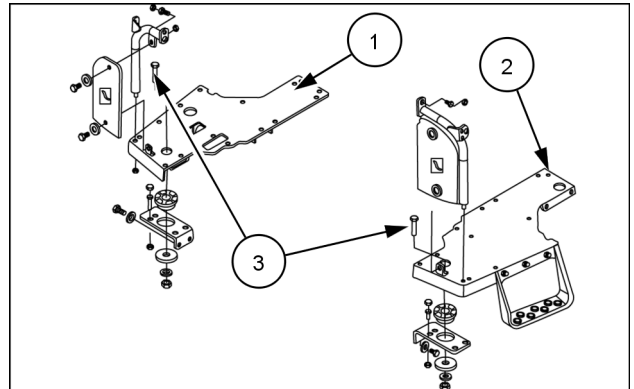

93102244 11

14. Install the pedals (1) and secure with bolts (2).

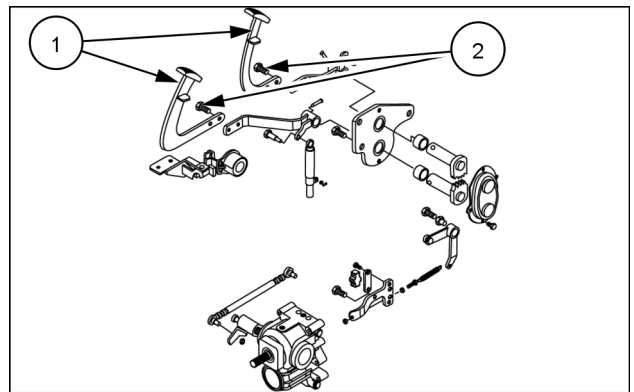

93102243 12



**Suggest:**

**If the above button click is invalid.**

**Please download this document**

**first, and then click the above link**

**to download the complete manual.**

**Thank you so much for reading**

15. Install the cover **(2)** and secure with the M8 nuts and bolts.
16. Install the mat **(1)**.

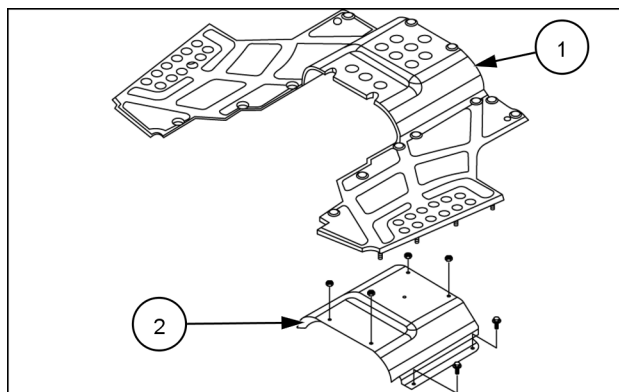

93102242 13

17. Install the four screws **(3)**, and secure the lower panel **(4)**.
18. Install the four knobs **(2)** on both rear cover halves **(1)**.

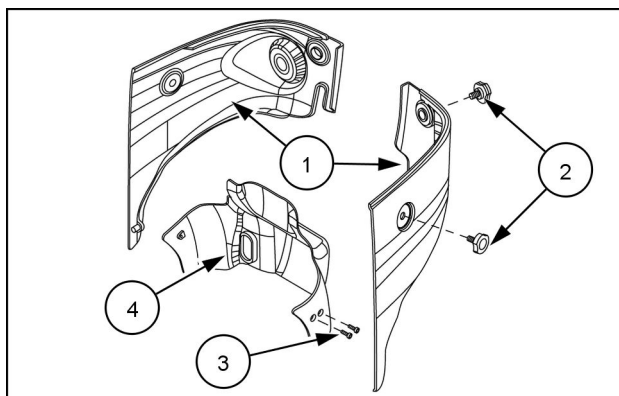

NHIL16CT00122AA 14

19. Assemble the suction tube assembly **(2)** and secure it with the clamps **(1)**.

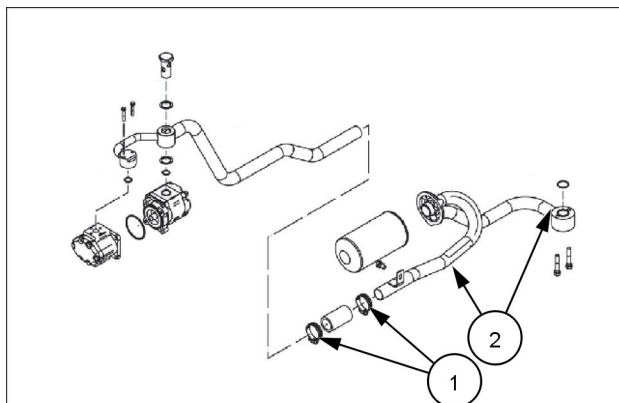

NHIL14CT00485FA 15

20. Connect the fuel hose, and then turn on the fuel supply at the filter **(1)**.
21. Connect the main and engine wire harnesses.
22. **Hood - Install (90.100).**
23. Connect the headlight wire harness.

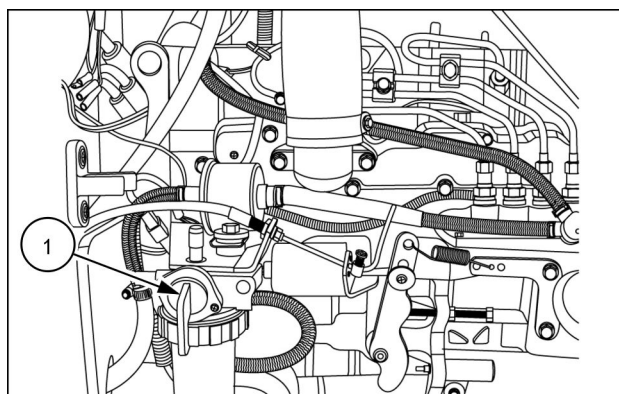

93102239 16

**<https://www.ebooklibonline.com>**

Hello dear friend!

Thank you very much for reading.

Enter the link into your browser.

The full manual is available for immediate download.

**<https://www.ebooklibonline.com>**