FARMALL 31, FARMALL 35 REPAIR MANUAL COMPLETE CONTENTS

SECTION 00 - GENERAL INFORMATION	2
SECTION 10 - ENGINE	3
SECTION 18 - CLUTCH	11
SECTION 21 - GEAR TRANSMISSION	12
SECTION 25 - FWD FRONT AXLE	15
SECTION 27 - DIFFERENTIAL, REAR AXLE	17
SECTION 29 - HYDROSTATIC TRANSMISSION	18
SECTION 31 - POWER TAKE-OFF SYSTEMS	22
SECTION 33 - BRAKES	24
SECTION 35 - HYDRAULIC SYSTEM	24
SECTION 41 - STEERING SYSTEMS	28
SECTION 44 - WHEELS AND TIRES	30
SECTION 55 - ELECTRICAL SYSTEM	31
SECTION 90 - PLATFORM	39

The following pages are the collation of the contents pages from each section and chapter of the Farmall 31, Farmall 35 Repair manual. Complete Repair part # 84132127.

The sections used through out all Case IH product Repair manuals may not be used for each product. Each Repair manual will be made up of one or several books. Each book will be labeled as to which sections are in the overall Repair manual and which sections are in each book.

The sections listed above are the sections utilized for the Farmall 31, Farmall 35 Tractors.

SAFETY

PRECAUTIONARY STATEMENTS

A careful operator is the best operator. Most accidents can be avoided by observing certain precautions. To help prevent accidents, read the following precautions before operating this equipment. Equipment should be operated only by those who are responsible and instructed to do so.

Carefully review the procedures given in this manual with all operators. It is important that all operators be familiar with and follow safety precautions.

THE TRACTOR

1. Read the Operator's Manual carefully before using the tractor. Lack of operating knowledge can lead to accidents.
2. Use an approved roll bar and seat belt for safe operation. Overturning a tractor without a roll bar can result in death or injury. If your tractor is not equipped with a roll bar and seat belt, see your Case IH Dealer.
3. Always use the seat belt. The only instance when the seat belt should not be used is if the roll bar has been removed from the tractor.
4. If a front end loader is to be installed, always use a FOPS (Falling Object Protective Structure) canopy to avoid injury from falling objects.
5. Use the handholds and step plates when getting on and off the tractor to prevent falls. Keep steps and platform cleared of mud and debris.
6. Do not permit anyone but the operator to ride on the tractor. There is no safe place for extra riders.
7. Keep all safety decals clean of dirt and grime, and replace all missing, illegible, or damaged safety decals. See the list of decals in the Decal section of this manual.
3. Keep the tractor and equipment, particularly brakes and steering, maintained in a reliable and satisfactory condition to ensure your safety and comply with legal requirements.
4. Keep open flame or cold weather starting aids away from the battery to prevent fires or explosions. Use jumper cables according to instructions to prevent sparks which could cause explosion.
5. Stop the engine before performing any service on the tractor.
6. Escaping hydraulic/diesel fluid under pressure can penetrate the skin causing serious injury. If fluid is injected into the skin, obtain medical attention immediately or gangrene may result.
 - DO NOT use your hand to check for leaks. Use a piece of cardboard or paper to search for leaks.
 - Stop the engine and relieve pressure before connecting or disconnecting lines.
 - Tighten all connections before starting the engine or pressurizing lines.
7. Do not modify or permit anyone else to modify or alter this tractor or any of its components or functions without first consulting a Case IH Dealer.

SERVICING THE TRACTOR

1. The cooling system operates under pressure which is controlled by the radiator cap. It is dangerous to remove the cap while the system is hot. Always turn the cap slowly to the first stop and allow pressure to escape before removing the cap entirely.
2. Keep any type of open flame away from the tractor and do not smoke while refueling. Wait for the engine to cool before refueling.
8. The fuel oil in the injection system is under high pressure and can penetrate the skin. Unqualified persons should not remove or attempt to adjust a pump, injector, nozzle, or any other part of the fuel injection system. Failure to follow these instructions can result in serious injury.
9. Continuous long-term contact with used engine oil may cause skin cancer. Avoid prolonged contact with used engine oil. Wash skin promptly with soap and water.

SECTION 00 – GENERAL INFORMATION – CHAPTER 1

10. Some components of your tractor, such as gaskets and friction surfaces (brake linings, clutch linings, etc.) may contain asbestos. Breathing asbestos dust is dangerous to your health. You are advised to have any maintenance or repair on such components carried out by an authorized Case IH Dealer. However, if service operations are to be undertaken on parts that contain asbestos, the essential precautions listed below must be observed:
 - Work out of doors or in a well ventilated area.
 - Dust found on the tractor or produced during work on the tractor should be removed by extraction, not by blowing.
 - Dust waste should be dampened, placed in a sealed container, and marked to ensure safe disposal.
 - If any cutting, drilling, etc. is attempted on materials containing asbestos, the item should be dampened and only hand tools or low speed power tools used.
9. Pull only from the drawbar or the lower link drawbar in the down position. Use only a drawbar pin that locks in place. Pulling from the tractor rear axle or any point above the axle may cause the tractor to upset.
10. If the front end of the tractor tends to rise when heavy implements are attached to the three-point hitch, install front end or front wheel weights. Do not operate the tractor with a light front end.
11. Always set the hydraulic selector lever in position control when attaching or transporting equipment. Ensure hydraulic couplers are properly mounted and will disconnect safely in case of accidental detachment of implement.
12. Do not leave equipment in the raised position.
13. Use the flasher/turn signal lights and SMV signs when traveling on public roads both day and night (unless prohibited by law).
14. When operating at night, adjust lights to prevent blinding oncoming drivers.

OPERATING THE TRACTOR

1. Before starting the tractor, apply the parking brake, place the PTO lever in the “OFF” position, the lift control lever in the down position, the remote control valve levers in the neutral position, and the transmission in neutral.
2. Always sit in the tractor seat when starting the engine or operating controls. Do not start the engine or operate controls while standing beside the tractor.
3. Do not bypass the neutral start switches. Consult your Case IH Dealer if your neutral start controls malfunction. Use jumper cables only in the recommended manner. Improper use can result in tractor runaway.
4. Avoid accidental contact with the gear shift lever while the engine is running, as this can cause unexpected tractor movement.
5. Before getting off the tractor, disengage the PTO, turn the engine off, and apply the parking brake. Never get off the tractor while it is in motion.
6. Do not park the tractor on a steep incline.
7. Do not operate the tractor engine in an enclosed building without adequate ventilation. Exhaust fumes can cause death or illness.
8. If the power steering or engine ceases operating, stop the tractor immediately.

DRIVING THE TRACTOR

1. Watch where you are going, especially at row ends, on roads, around trees and low hanging obstacles.
2. To avoid upsets, drive the tractor with care and at a safe speed. Use extra caution when operating over rough ground, when crossing ditches or slopes, and when turning corners.
3. To provide two-wheel braking, lock tractor brake pedals together when transporting on roads.
4. Do not coast or free wheel down hills. Use the same gear when going downhill as is used when going uphill.
5. Any towed vehicle with a total weight exceeding that of the towing tractor should be equipped with brakes for safe operation.
6. If the tractor becomes stuck or the tires become frozen to the ground, back up the tractor to prevent upset.
7. Always check overhead clearance, especially when transporting the tractor.
8. When operating at night, adjust lights to prevent blinding oncoming drivers.

<https://www.ebooklibonline.com>

Hello dear friend!

Thank you very much for reading.

Enter the link into your browser.

The full manual is available for immediate download.

<https://www.ebooklibonline.com>

OPERATING THE PTO

1. When operating PTO driven equipment, shut off the engine and wait until the PTO stops before getting off the tractor and disconnecting the equipment.
2. Do not wear loose clothing when operating the power take-off or when near rotating equipment.
3. When operating stationary PTO driven equipment, always place both gear shift levers in neutral, apply the tractor parking brake, and block the rear wheels front and back.
4. To avoid injury, do not clean, adjust, unclog, or service PTO driven equipment when the tractor engine is running.
5. Ensure the PTO master shield is installed at all times. Always replace the PTO shield cap when the PTO is not in use.

DIESEL FUEL

1. UNDER NO CIRCUMSTANCES should gasoline, alcohol, or blended fuels be added to diesel fuel. These combinations can create an increased fire or explosive hazard. Such blends are more explosive than pure gasoline in a closed container such as a fuel tank. **DO NOT USE THESE BLENDS.**
2. Never remove the fuel cap or refuel with the engine running or hot.
3. Do not smoke while refueling or when standing near fuel.
4. Maintain control of the fuel filler pipe nozzle when filling the tank.
5. Do not fill the fuel tank to capacity. Allow room for expansion.

6. Wipe up spilled fuel immediately.
7. Always tighten the fuel tank cap securely.
8. If the original fuel tank cap is lost, replace it with a Case IH approved cap. A non-approved, proprietary cap may not be safe.
9. Keep equipment clean and properly maintained.
10. Do not drive equipment near open fires.
11. Never use fuel for cleaning purposes.
12. Arrange fuel purchases so that winter grade fuels are not held over and used in the spring.

SAFETY FRAME (ROPS)

Your Case IH tractor is equipped with a safety frame. It must be maintained in a serviceable condition. Be careful when driving through doorways or working in confined spaces with low headroom.

UNDER NO CIRCUMSTANCES should you:

- modify, drill, or alter the safety frame in any way. Doing so may render you liable to legal prosecution.
- attempt to straighten or weld any part of the main frame or retaining brackets which have suffered damage. Doing so may weaken the structure and endanger your safety.
- secure any parts on the main frame or attach your safety frame with anything other than the special high tensile bolts and nuts specified.
- attach chains or ropes to the main frame for pulling purposes.
- take unnecessary risks even though your safety frame affords you the maximum protection possible.



WHEN YOU SEE THIS SYMBOL

IT MEANS:

ATTENTION!

BECOME ALERT!

YOUR SAFETY IS INVOLVED!

SECTION 10 - ENGINE

Chapter 1 - Engine Systems

CONTENTS

Section	Description	Page
	Specifications	6
	Cooling System All Models	13
	Engine Bolt Torque Specifications	14
	Engine Fuel System Bolt Torque Specifications	14
	Metric Bolt Torque Specifications	15
	Special Tools	16
	Compression Test and Tools	16
	Description of Operation – General Information	17
	Cylinder Head and Valve Train Components	18
	Cylinder Block Assembly	18
	Troubleshooting	20
	Overhaul	24
	Engine	24
	Preparation	24
	Fuel Injector and Glow Plug	25
	Removal	25
	Oil Pressure Switch	26
	Removal	26
	Temperature Sending Switch and Alternator	26
	Removal	26
	Fan, Water Pump and External Oil Tube	26
	Removal	26
	Head Cover	27
	Removal	27
	Rocker Arm Shaft and Support Bracket	27
	Removal	27
	Cylinder Head	28
	Removal	28
	Valve Tappet	28
	Removal	28
	Fuel Shutoff Solenoid	28
	Removal	28

SECTION 10 - ENGINE - CHAPTER 1

Section	Description	Page
	Timing Gear Cover	29
	Removal	29
	Timing Gears and Camshaft	30
	Removal	30
	Oil Sump	30
	Removal	30
	Oil Suction Pipe and Strainer	31
	Removal	31
	Connecting Rods, Bearings, Pistons and Rings	31
	Removal	31
	Flywheel	32
	Removal	32
	Backplate and Oil Seal	32
	Removal	32
	Front Crankshaft Gear	32
	Removal	32
	Crankshaft and Main Bearings	33
	Removal	33
	Cylinder Head	34
	Disassembly	34
	Inspection and Repair	34
	Valve Seats	35
	Inspection and Repair	35
	Valves	36
	Inspection and Replacement	36
	Valve Guides	37
	Inspection and Replacement	37
	Valve Springs	38
	Inspection and Replacement	38
	Rocker Arms	38
	Inspection and Replacement	38
	Push Rods	39
	Inspection and Replacement	39
	Cylinder Block	40
	Inspection	40

SECTION 10 - ENGINE - CHAPTER 1

Section	Description	Page
	Pistons	41
	Disassembly and Inspection	41
	Piston Rings	43
	Disassembly and Inspection	43
	Connecting Rods	43
	Disassembly and Inspection	43
	Pin to Bushing Clearance	44
	Connecting Rod Bearing Oil Clearance Check	45
	Pistons, Rings and Connecting Rod	46
	Assembly	46
	Main Bearing and Thrust Washer	47
	Removal and Inspection	47
	Crankshaft	47
	Inspection	47
	Crankshaft Bearing (Bushing)	48
	Inspection	48
	Replacement	49
	Crankshaft Front Gear, Main Bearings and Thrust Washers	49
	Assembly	49
	Port Block	51
	Removal	51
	Installation	51
	Timing Gear	51
	Inspection	51
	Camshaft	52
	Disassembly	52
	Inspection	52
	Assembly	52
	Flywheel	53
	Inspection and Repair	53
	Timing Gear Housing	53
	Front Oil Seal and Steering Pump Seal	53
	Replacement	53
	Crankshaft and Bearing Holder	54
	Installation	54
	Rear Oil Seal and Backplate	54
	Installation	54
	Flywheel	55

SECTION 10 - ENGINE - CHAPTER 1

Section	Description	Page
	Installation	55
	Pistons and Connecting Rods	55
	Installation	55
	Oil Suction Pipe and Suction Strainer	56
	Installation	56
	Oil Sump	56
	Installation	56
	Camshaft and Camshaft Gear	57
	Installation	57
	Idle Gear, Oil Pump and Injection Timing	57
	Installation	57
	Timing Gear Cover	57
	Installation	57
	Crankshaft Pulley	58
	Installation	58
	Fuel Injection Pump	58
	Installation	58
	Power Steering Pump	58
	Installation	58
	Head Gasket Selection	59
	Cylinder Head	59
	Assembly	59
	Valve Clearance Adjustment	60
	Head Cover	60
	Installation	60
	Water Pump and Cooling Fan	60
	Installation	60
	External Oil Tube	61
	Installation	61
	Glow Plug and Connector	61
	Installation	61
	Fuel Injector	61
	Installation	61
	Fuel Piping	62
	Installation	62
	Alternator and Temperature Sender Switch	62
	Installation	62
	Exhaust Manifold	62

SECTION 10 - ENGINE - CHAPTER 1

Section	Description	Page
	Installation	62
	Description of Operation – Engine Lubrication System	63
	Oil Filter	66
	Construction and Function	66
	Maintenance	66
	Oil Pump	66
	Removal	66
	Inspection	66
	Installation and Adjustment	67
	Engine Oil Pressure Check	68
	Oil Pressure Relief Valve	69
	Removal	69
	Installation	69
	Oil Consumption	70
	Description of Operation – Cooling System	71
	Maintenance	72
	Coolant	72
	Radiator Cap	72
	Thermostat	73
	Water Pump	73
	Cooling Fan	73
	Overhaul	74
	Radiator	74
	Removal	74
	Inspection and Repair	76
	Installation	76
	Water Pump	78
	Removal	78
	Inspection and Repair	79
	Installation	79
	Thermostat	80
	Removal	80
	Inspection and Repair	81
	Installation	81

SECTION 10 - ENGINE - CHAPTER 1

SPECIFICATIONS

GENERAL	Farmall 31	Farmall 35
Net Power Hp in Kw (Hp)	21.9 (29.4)	24.9 (33.4)
Gross Engine in Kw(Hp)	23.1 (31)	26.1 (35)
PTO in Kw(Hp) w/9 x 3 w/HST	19.8 (26.3) 18.6 (24.9)	— 21.6 (28.9)
Engine Model	N843	N843L
Number of Cylinders	3	3
Bore x Stroke in mm (in.)	84 x 90 (3.31 x 3.54)	84 x 100 (3.31 x 3.94)
Displacement in L(In ³)	1.50 (91.3)	1.662 (101.5)
Compression Ratio	22.2:1	23.3:1
Rated Speed in rpm	2600	2600
Muffler Location	Under Hood	Under Hood
Firing Order	1-2-3	1-2-3
Low Idle Speed in rpm	1050 - 1150	1050 - 1150
High Idle Speed in rpm	2800 - 2850	2800 - 2850
Cylinder Arrangement	In-line Vertical	In-line Vertical
Valve Arrangement	Overhead	Overhead
CYLINDER BLOCK	Farmall 31	Farmall 35
Bore Standard in mm (in.)	84 - 84.019 (3.307 - 3.308)	84 - 84.019 (3.307 - 3.308)
Bore Maximum in mm (in.)	84.2 (3.315)	84.2 (3.315)
Head Surface Warp Standard in mm (in.)	0.05 (0.002)	0.05 (0.002)
Head Surface Warp Maximum in mm (in.)	0.12 (0.005)	0.12 (0.005)

OVERHAUL

ENGINE

Preparation

1. Turn coolant tap bolt, 1, counterclockwise to drain fluid. Remove the radiator assembly. See "Radiator Removal", discussed later in this section.

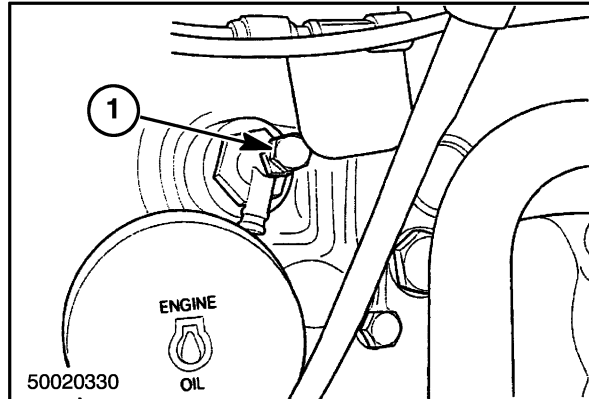

5

2. Remove bolts, 1, fastening the air cleaner assembly, 2, to the tractor. Remove the mounting bracket, 3, from engine.

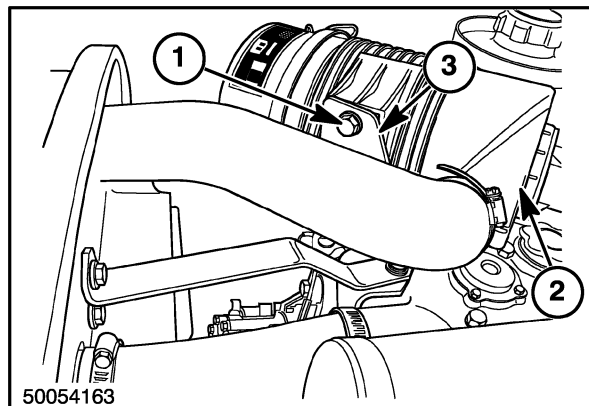

6

- Remove the exhaust muffler, 1, and manifold assembly, 2. Loosen bolt, 3, and bolt, 4, Figure 8, to remove exhaust muffler. Loosen six bolts, 5, to remove exhaust manifold.

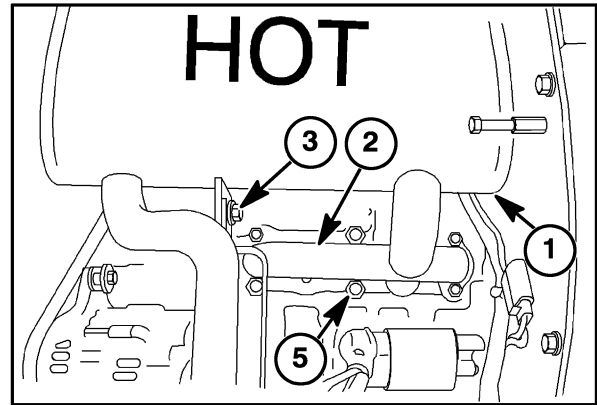

7

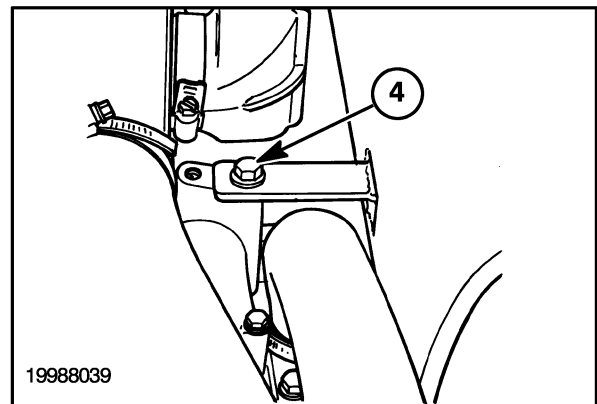

19988039

8

FUEL INJECTOR AND GLOW PLUG

Removal

- Clean all dirt and oil from the injectors and surrounding areas.
- Disconnect the fuel lines, 1, from the injectors and cap all openings.
- Remove the injector fuel leak-off line, 2.
- Remove the injector assemblies, 3.
- Remove the glow plug bus connector, 4, and remove the glow plugs, 5.

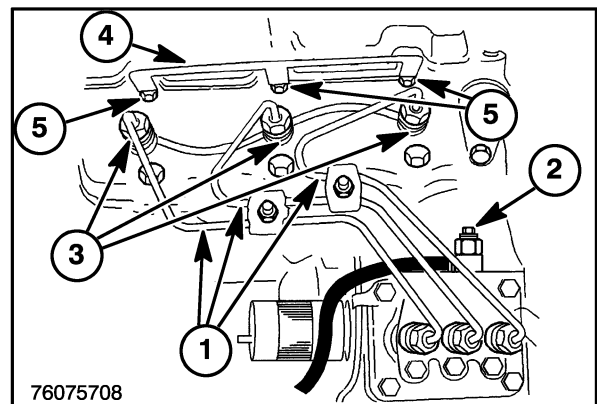

76075708

9

OIL PRESSURE SWITCH

Removal

Remove the oil pressure switch, 1.

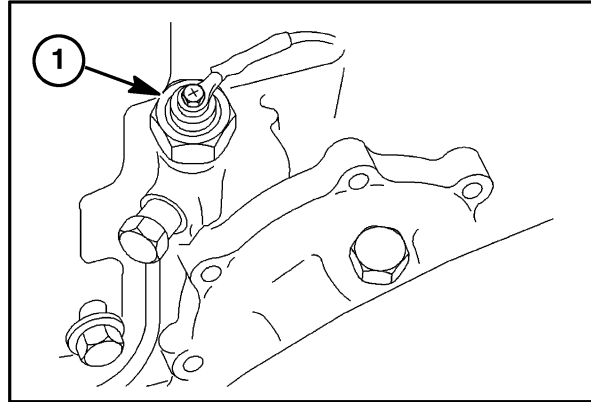

10

TEMPERATURE SENDING SWITCH AND ALTERNATOR

Removal

1. Remove the temperature sending switch, 1, from the front of the cylinder head.
2. Loosen the alternator mounting bolts, 2, and remove the V-belt, 3, from the drive pulley.
3. Disconnect the alternator wires from the back of alternator, 4.
4. Remove the alternator mounting bolts, 2, and remove the alternator.

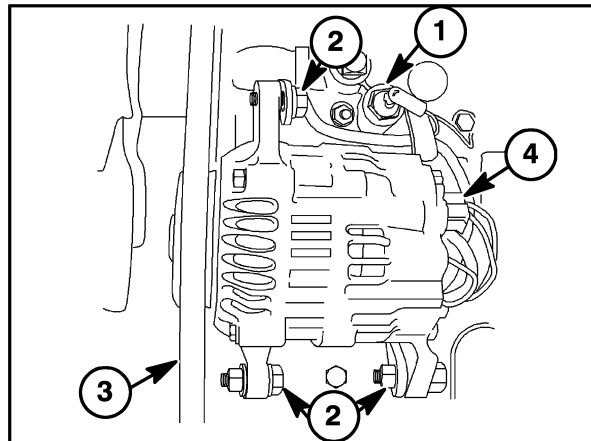

11

FAN, WATER PUMP AND EXTERNAL OIL TUBE

Removal

1. Remove the fan and water pump assembly. See "Fan Removal" and "Water Pump Removal" discussed later in this section.
2. Remove the external oil transfer tube banjo bolt, 1, from the front of the cylinder head.

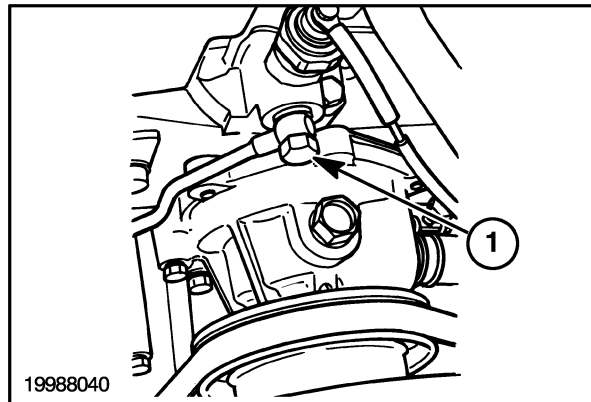

12

HEAD COVER

Removal

Remove the retaining bolts, 1, cap nuts, 2, and seal washers, 3. Remove the head cover, 4, with gasket, 5.

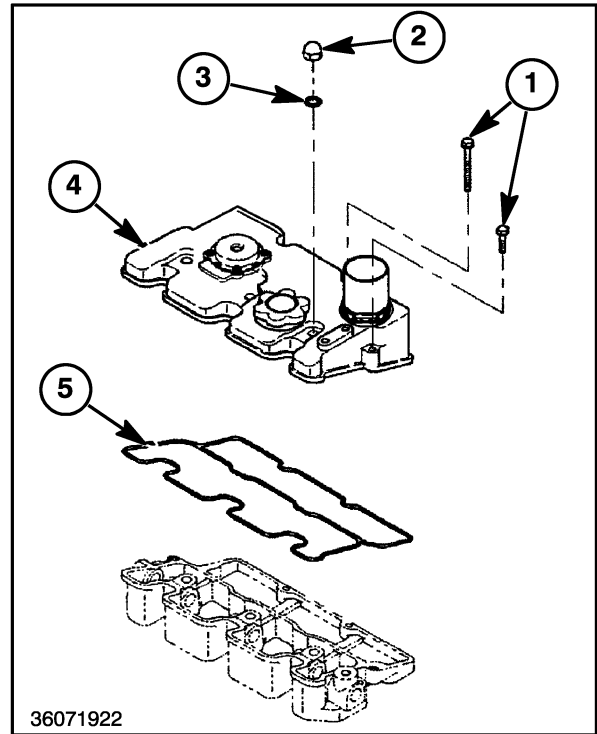

13

ROCKER ARM SHAFT AND SUPPORT BRACKET

Removal

Remove the bolts, 1, and nuts, 2. Remove the rocker arm shaft and support bracket as an assembly, 3, and gasket, 4.

NOTE: Alternately loosen the rocker support bolts a turn at a time to prevent distorting the rocker shaft.

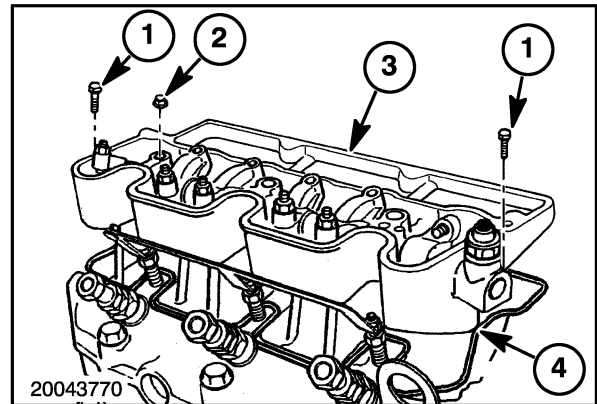

14

CYLINDER HEAD

Removal

1. Remove the valve stem caps, 1, and push rods, 2.

NOTE: Keep all valve components in separately marked containers for re-assembly in their original location.

2. To remove the cylinder head, remove the cylinder head bolts, 3, by alternately loosening a half turn at a time to prevent warping the head.

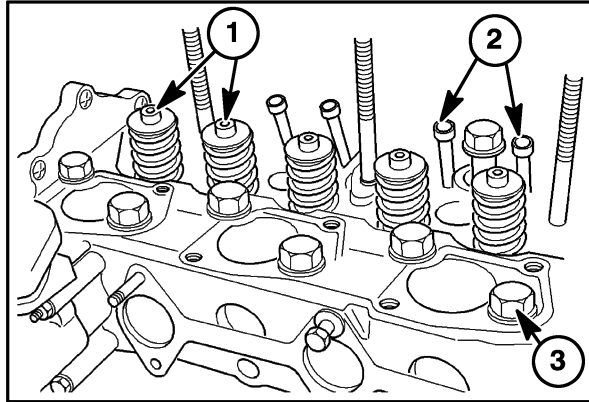

15

VALVE TAPPET

Removal

Remove the valve tappets, 1, from the machined bore in the cylinder block.

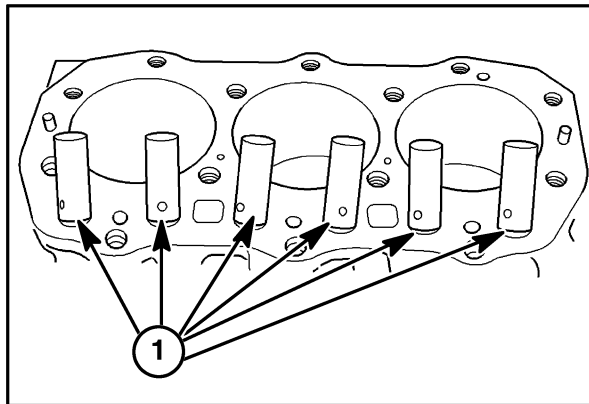

16

FUEL SHUTOFF SOLENOID

Removal

Remove the wire connector and unscrew the fuel shutoff solenoid, 1.

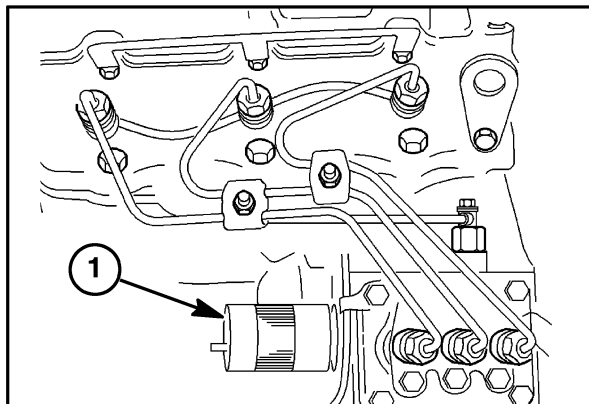

17

TIMING GEAR COVER

Removal

1. Drain the engine crankcase oil.
2. Remove the crankshaft pulley.
3. Remove fuel shut off solenoid from engine block.
4. Loosen the four injection pump retaining nuts from mounting studs, 1, and raise the injection pump, 2, enough to remove the spring pin, 3, and separate the governor link from the control rack. Remove the injection pump.

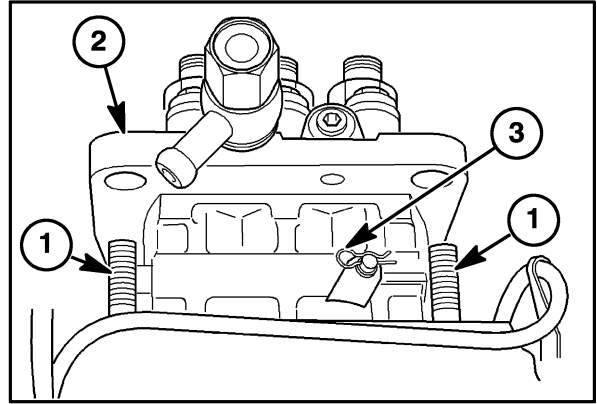

18

5. Loosen the hose clamp, 1, on the suction hose, 2, and remove the return hose from the power steering unit, 3.
6. Remove the pressure tube, 4, from the bottom of the steering pump.
7. Remove the through bolts, 5, and remove the steering pump from the front cover. Cap the lines and pump openings.

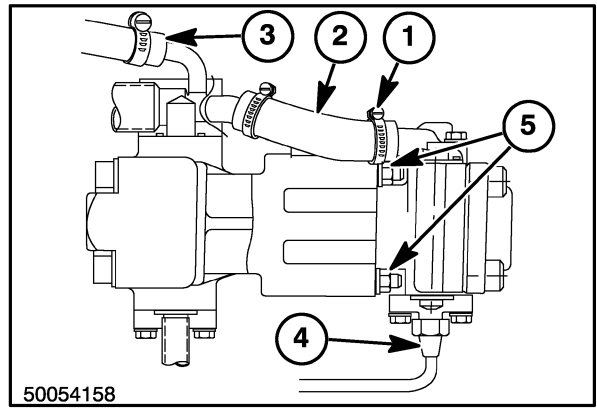

50054158

19

8. Remove the retaining bolts, 1, and lift the cover, 2, off the locating dowels.

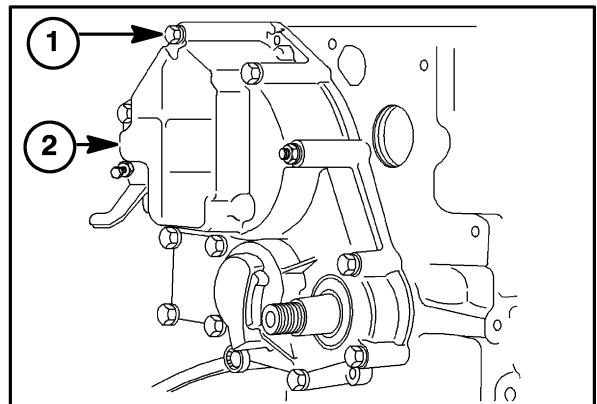

20

TIMING GEARS AND CAMSHAFT

Removal

1. Remove retaining ring, 1, idler gear, 2, and oil pump assembly, 3.

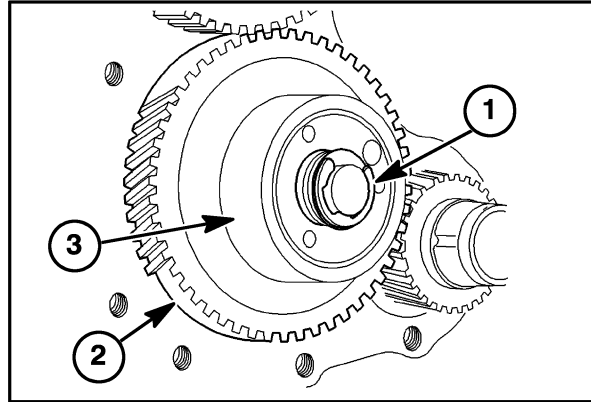

21

2. Remove the two bolts, 1, securing the keeper plate, 2. One must be accessed using the access hole, 3, in the cam gear.
3. Slide the camshaft and gear out of the camshaft bore.

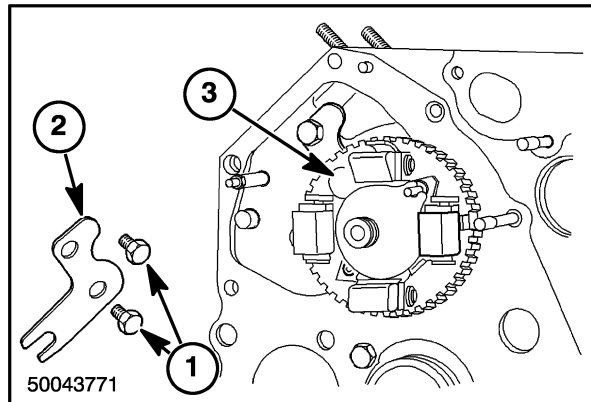

22

OIL SUMP

Removal

1. Remove the oil sump retainer bolts, 1.
2. Remove the oil sump and discard gasket.

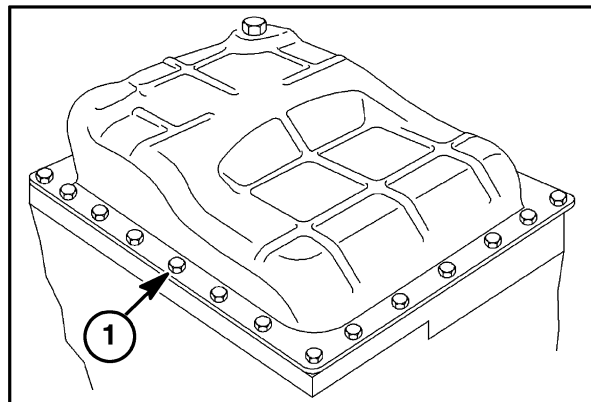

23

OIL SUCTION PIPE AND STRAINER

Removal

1. Remove the two retaining bolts, 1.
2. Remove the oil strainer, 2, and rotate the oil suction pipe, 3, out of its bore. Remove from the front side of the block.

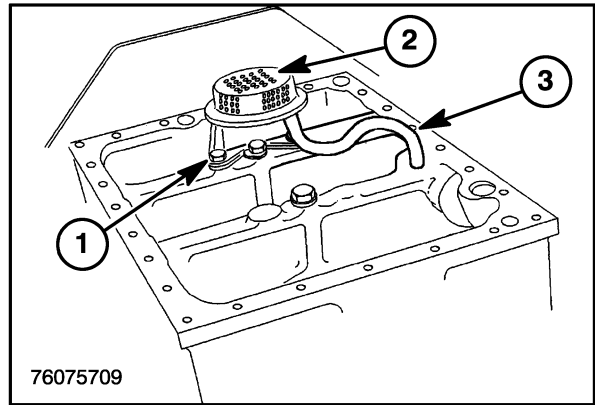

24

CONNECTING RODS, BEARINGS, PISTONS AND RINGS

Removal

1. Remove the two bolts, 1, retaining the connecting rod caps, 2.
2. Remove the connecting rod caps and lower half of connecting rod bearing.
3. If necessary, remove any burrs from the top of the cylinder bores using a suitable reamer.

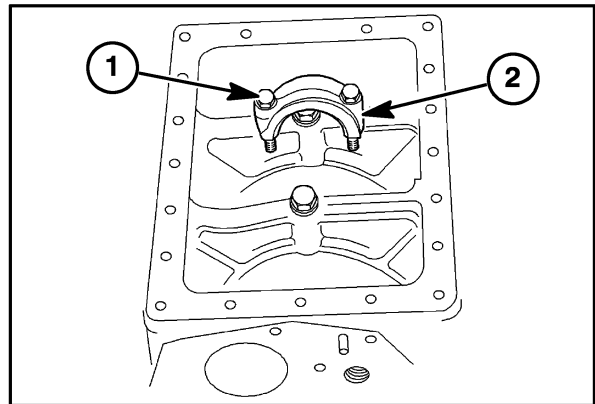

25

4. Push the piston and connecting rod out of the cylinder block.
5. Replace the connecting rod cap to the piston assembly it was removed from. Keep together in cylinder sequence.

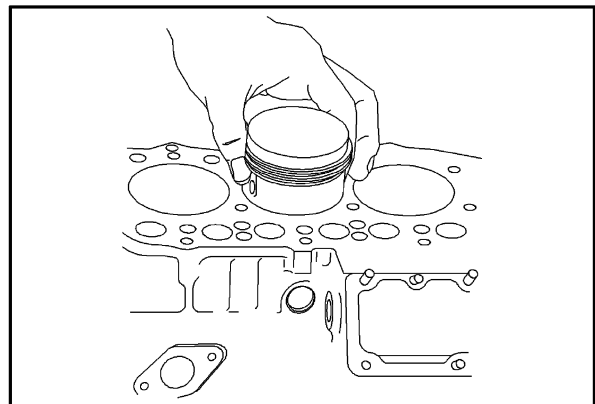

26

FLYWHEEL

Removal

1. Loosen the flywheel retaining bolts.
2. Using a brass drift and hammer, tap the end of the crankshaft, 1, to loosen the flywheel, 2, from the shaft.

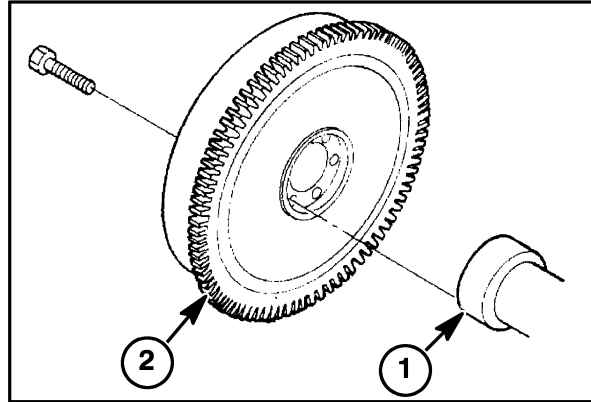

27

BACKPLATE AND OIL SEAL

Removal

1. Remove the backplate retaining bolts and remove the backplate.
2. Remove the rear oil seal, 1.

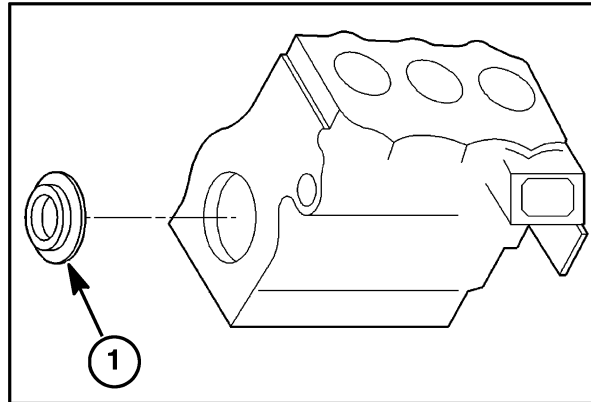

28

FRONT CRANKSHAFT GEAR

NOTE: The crankshaft gear does not need to be removed to pull crankshaft from engine block. Only remove the gear if there are signs of wear or damage. Replace if any defects are found.

Removal

1. Remove two bolts, 1, front plate, 2, and gasket from the engine block, 3.

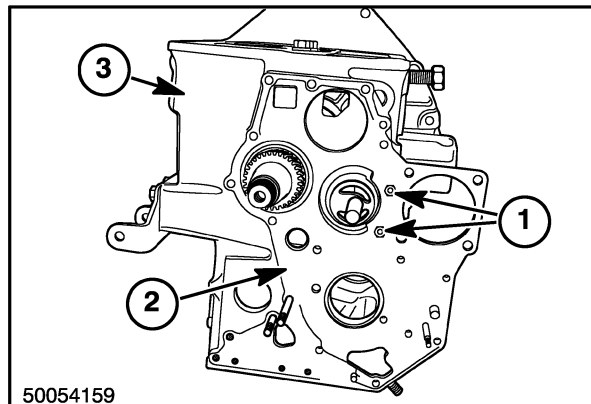

50054159

29

SECTION 10 - ENGINE - CHAPTER 1

2. Place suitable gear puller, 1, behind front crankshaft gear, 2, as shown.
3. Remove the front crankshaft gear, 2.

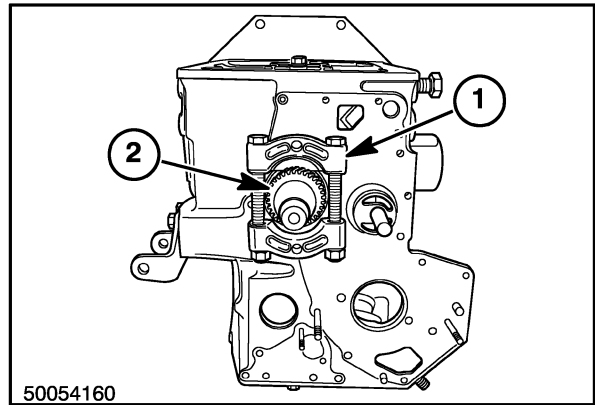

30

CRANKSHAFT AND MAIN BEARINGS

Removal

1. Remove the crankshaft bearing holder retaining bolts, 1.
2. Slide the crankshaft and main bearing assembly through the rear of the engine.

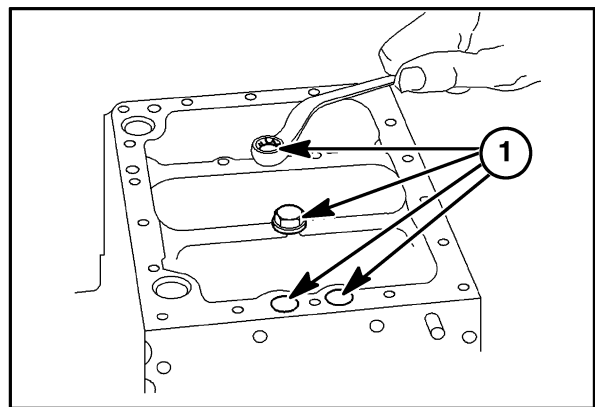

31

CYLINDER HEAD

Disassembly

1. Clean the cylinder head and remove any carbon deposits from around the valve heads.
2. Use a valve spring compressor and remove the valve spring retainer locks, 1, spring, 2, and spring retainer, 3, from each valve, 4.
3. Remove the valve guide seal, 5, from the cylinder head.
4. Remove the valves and place the valve components together in separately marked containers for reassembly in their original position.

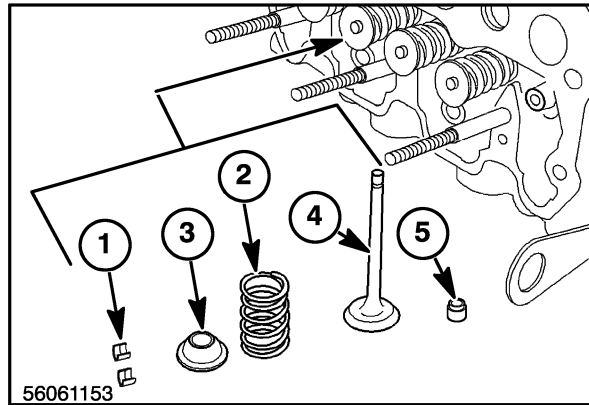

32

Inspection and Repair

1. Clean all carbon deposits from the combustion chamber and valve ports using a wire brush and scraper.
2. Clean all dirt and residue from the gasket surface using care not to scratch or nick the machined surface.
3. Clean the cylinder head in solvent and air dry.
4. Inspect the head for cracks or damage in the following areas:
 - Valve ports
 - Valve seats, 1
 - Prechamber, 2
 - External cracks in the water jackets, 3
5. Inspect the gasket surfaces for scratches or nicks, which could cause leakage.
6. Examine the core hole plugs for rust or signs of leakage. If a plug shows signs of damaging rust or leakage, replace all plugs in the head.
7. Inspect the prechamber for carbon deposits and looseness. Remove any carbon deposits found. If prechamber is found to be loose, cylinder head may be warped.

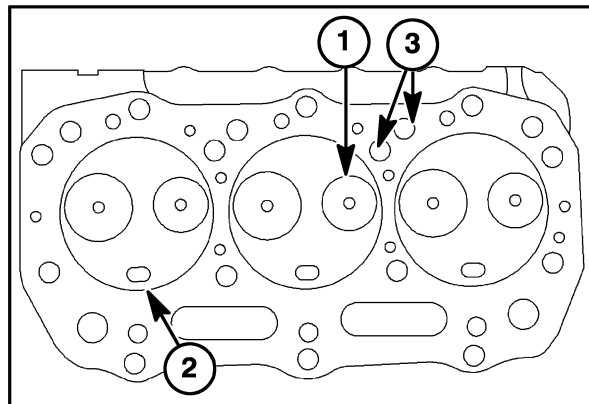

33

- Use a straight edge and a feeler gauge and check the cylinder head for warp lengthwise, crosswise, and diagonally.

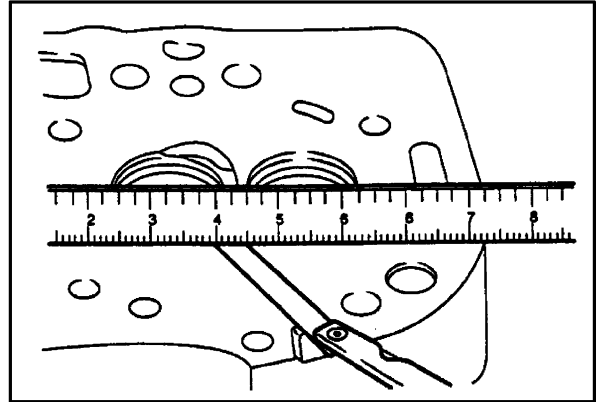

34

VALVE SEATS

Inspection and Repair

Examine the valve seats and surface the seat if damaged. Valve seat grinding requires that the seat be ground to the correct width and properly positioned. A valve that extends too deep into the combustion area will result in valve burning. If the valve is recessed too deep into the head it will cause a rapid build-up of carbon deposits.

- Check the seat for surface defects. Use a 45° stone if necessary to reface. Grind away only enough material to provide a smooth even seat.

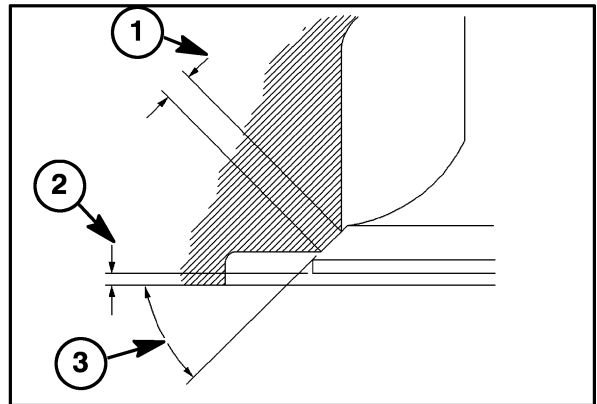

35

- Correct Valve Seat Width and Location
- Correct Valve Head Margin N843 0.7 - 1.0 mm (0.027 - 0.039 in)
- 45° Valve Seat Angle

- Check the seat width. If necessary, use a 15° stone to lower the seat contact point and use a 75° stone to raise the seat contact point.

NOTE: Refacing the seat should always be coordinated with refacing of the valve to ensure a compression tight fit.

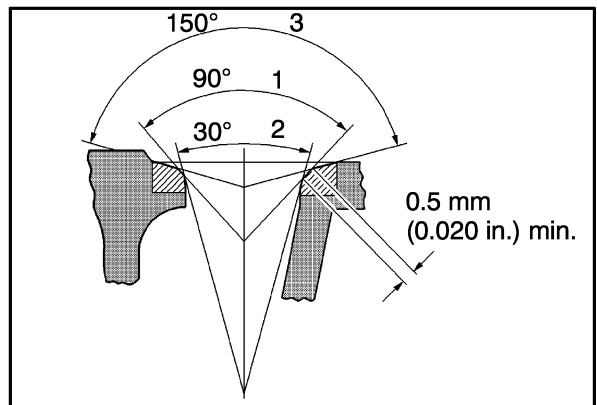

36

- Seat angle - 45° Stone
- Lower Seat Location - 15° Stone
- Raise Seat Location - 75° Stone

VALVES

Inspection and Replacement

1. Clean all deposits from the valves using a soft wire brush. Inspect the condition of the valves and discard any that are badly burned, cracked, or bent.

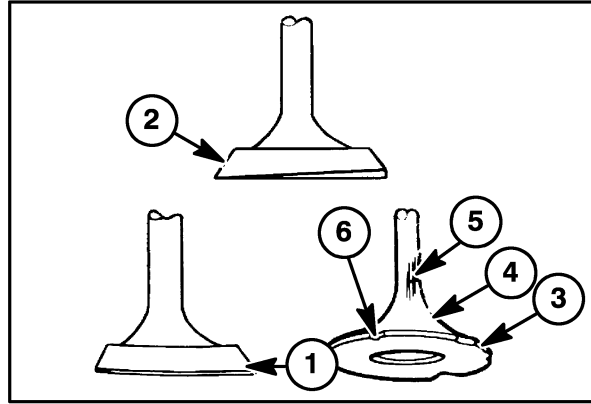

37

1. Margin Too Thin
Min. 0.5 mm (0.02 in)
2. Bent Valve
3. Pitting
4. Indented
5. Wear or Nicking
6. Burned

2. Using a micrometer, measure the valve stem at points "A," "B" and "C."

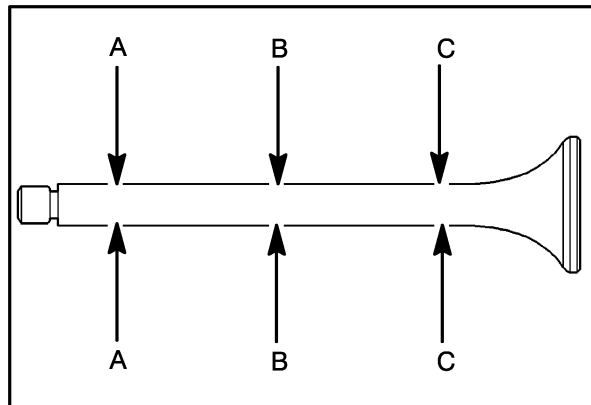

38

3. If inspection indicates that the valve may be reused, the valve should be ground.
4. After grinding the valve and seat, check to ensure the seat contacts the center of the valve face. Using Prussian Blue, lightly coat the valve seat, place the valve in position and rotate the valve slightly while holding a light pressure against the valve. If the blue is transferred to the center of the valve face, the contact is correct.

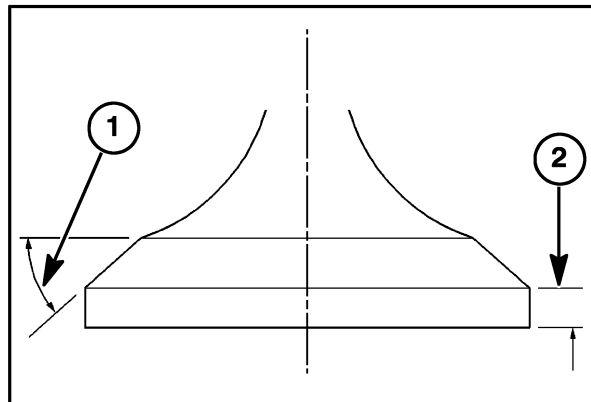

39

1. 45° Angle Seat
2. Minimum Valve Margin

5. If Prussian Blue is not available, mark the valve face or seat, 1, with a soft lead pencil. Rotate the valve slightly in the seat. The penciled lines will be broken at the seat contact area.

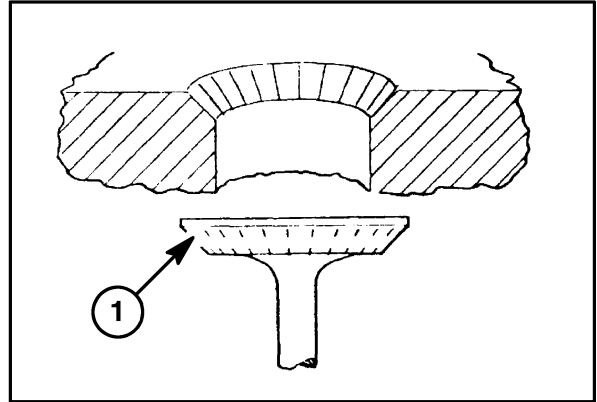

40

VALVE GUIDES

Inspection and Replacement

Thoroughly clean the valve guides before attempting to check internal wear.

1. Using a telescoping gauge and micrometer, measure the valve guide bore at the top and bottom wear points, 1.

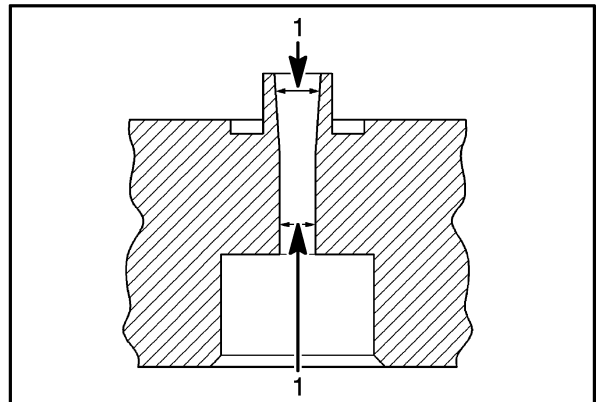

41

2. Determine the valve stem to valve guide clearance, 1, by subtracting the valve stem diameter from the valve guide diameter. Replace valves if the clearance, 1, is more than 0.2 mm (0.008 in), intake valves, or 0.25 mm (0.010 in), exhaust valves.
3. Replace the cylinder head if excessive clearance is determined and the valves have met all specified measurement requirements. See "Specifications," discussed later in this section.

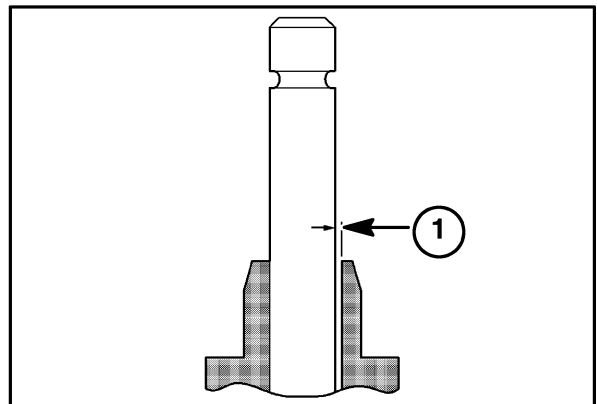

42



Suggest:

If the above button click is invalid.

Please download this document

first, and then click the above link

to download the complete manual.

Thank you so much for reading

VALVE SPRINGS

Inspection and Replacement

1. Place the valve springs on a flat surface. Measure the free length of the spring and squareness. Replace springs that do not meet the following specifications (all models):

Max. Out of Square	Min. Free-Length
2.0 mm (0.079 in)	33.5 mm (1.319 in)

2. Place the springs in a suitable spring load tester and measure the spring load rating. Replace springs that do not meet the following specifications (all models):

Standard	Maximum
8.1 kg (17.86 lbs) at 30.4 mm (1.197 in)	7 kg (15.43 lbs) at 30.4 mm (1.197 in)

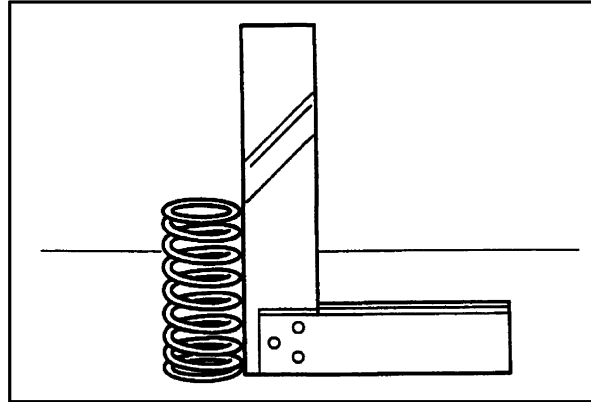

43

ROCKER ARMS

Inspection and Replacement

1. Rocker Arm
2. Shims
3. Spring
4. Rocker Arm Shaft

1. Thread an 8 mm bolt into the front end of the rocker shaft and slowly withdraw the rocker shaft while at the same time removing the rocker arms and springs.
2. Inspect the rocker arms and shaft for wear or damage. Check the adjusting screws for damaged threads or excessive wear.
3. Check the valve stem contact area for pitting or excessive wear. Slight wear patterns may be removed using a fine grit oil stone.

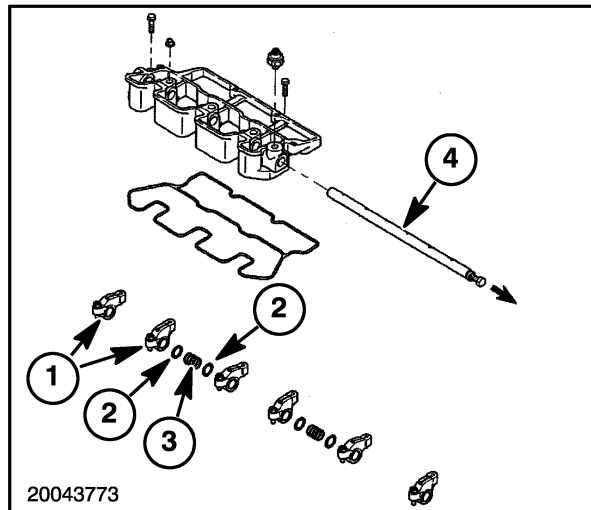

20043773

44

<https://www.ebooklibonline.com>

Hello dear friend!

Thank you very much for reading.

Enter the link into your browser.

The full manual is available for immediate download.

<https://www.ebooklibonline.com>