

CX50, CX60, CX70, CX80, CX90 and CX100 Tractors

Service Manual Don 7-71427

Table of Contents

	Section	Pub. No.
1 GENERAL		
Loctite Product Chart		8-98902
How it Works	1	7-70810
Safety Rules, General Information and Torque Specifications.....	1001	8-86531
General Specifications and Torques	1002	7-71854
Special Tools	1005	7-71865
2 ENGINE		
How it Works	2	7-70820
Engine Removal and Installation	2001	7-73780
NOTE: For Service and Overhaul procedures refer to your Engine Service Manual 7-71721.		
3 FUEL SYSTEM		
Fuel Tank Removal and Servicing.....	3005	7-72610
NOTE: For Service and Overhaul procedures refer to your Engine Service Manual 7-71721.		
4 ELECTRICAL		
How it Works and Electrical Schematics	4001	7-70200
Instrument Cluster Programming and Troubleshooting.....	4002	7-71332
Battery Servicing and Testing.....	4004	7-73210
5 STEERING		
Steering Column and Hand Pump.....	5001	7-72042
2WD Steering Cylinder	5002	7-71291
2WD Front Axle	5003	7-72001
6 TRANSMISSION		
How it Works	6	7-70830
Separating the Tractor (between Engine and Speed Transmission).....	6001	7-71890
Engine Clutch and Master Cylinder	6002	7-71900
Powershift and Forward/Reverse		
Transmission Servicing	6003	7-71921
Creep Transmission Servicing.....	6004	7-73490
8 Speed Transmission Servicing	6005	7-71270
Synchronizer Speed Transmission Servicing	6006	7-71930
Range Transmission Servicing (2WD)	6008	7-73740
Range Transmission Servicing (MFD).....	6009	7-71791
Rear Axles	6010	7-71110

... continued

NOTE: Information contained in this Manual may cover features that are not available in all markets worldwide.

CASE CORPORATION
700 State Street
Racine, WI 53404 U.S.A.

CASE CANADA CORPORATION
3350 South Service Road
Burlington, ON L7N 3M6 CANADA

Don 7-71437

Copyright © 2000 Case Corporation
Printed in U.S.A.
February 1998 (Revised October 2000)

MFD Transfer Gearbox, Drive Shaft and Parking Brake	6011	7-71310
Differential	6012	7-71120
Differential - from Transmission Serial Number JKA412637 and Creep Transmissions	6012	7-73760
PTO	6013	7-71130
Shiftable PTO	6014	7-71150
Front PTO	6015	7-71170
MFD Axle - up to Axle Serial Number 37835	6021	7-39121
MFD Axle - from Axle Serial Number 37836	6021	7-71190
7 BRAKES		
How it Works	7	7-70840
Service Brakes and Master Cylinder	7001	7-73770
Parking Brake (2WD)	7002	7-70970
Hydraulic Trailer Brake	7004	7-73750
8 HYDRAULICS (see note ** for this section)		
How it Works	8	7-70850
How to Read Symbols in a Hydraulic Schematic	8000	8-94372
Hydraulic Troubleshooting and Schematic	8001	7-71951
Filter Manifold and Main Hydraulic Pump	8002	7-71960
Steering Hydraulic Pump	8003	7-70980
Regulator Valve	8004	7-72030
Differential Lock Cylinder and Solenoid	8005	7-71660
Unloading Valve	8006	7-71670
Remote Valves	8007	7-71680
Hitch Valve and EDC Manifold	8009	7-71971
Hydraulic Housing and Lift Cylinder	8010	7-71370
Front Hitch	8011	7-71690
9 CHASSIS AND MOUNTED EQUIPMENT		
Pedal, Lever and Switch Adjustments	9001	7-72054
Air Conditioner System Component Servicing	9005	7-70740
Cab Removal and Tilting the Cab Roof	9006	7-71990
Cab Mountings	9008	7-73470
9 CONTROLLER SYSTEMS		
Calibration, Error Codes, Troubleshooting and Schematics (Tractors not equipped with Ride Control)	10002	7-74440
Calibration, Error Codes, Troubleshooting and Schematics (Tractors equipped with Ride Control)	10002	7-74450
Programming the Hitch/MFD/Differential Lock Controller	10010	7-74350

NOTE **

Please include section 8008 (7-71980) in this manual.

Section

1

GENERAL

How it Works

<https://www.ebooklibonline.com>

Hello dear friend!

Thank you very much for reading.

Enter the link into your browser.

The full manual is available for immediate download.

<https://www.ebooklibonline.com>



GENERAL OVERVIEW

The CX Series tractors are built in the Case factory at Doncaster, England. These machines are marketed in Europe, North America and in all other export markets served by the company. The tractors are available with two types of safety cabs, the delux cab or the low profile cab.

The range begins with the CX 50 which delivers 50 h.p. (37 Kw) and extends to the CX100 delivering 100 h.p. (74 KW).

Engines

The engines used in these tractors are Case 900 and 1000 Series which are produced in England. The CX50 and CX60 tractors use the three cylinder 900 Series and the CX70, CX80, CX90 and CX100 use the four cylinder 1000 Series engines.

The engines in the CX60 and CX80 are turbocharged, the engines in the CX90 and CX100 have Wastegate turbochargers.

MODELS	CX50	CX60	CX70	CX80	CX90	CX100
No. of Cyl	3	3	4	4	4	4
Max Power PS/KW	50/37	60/44	70/52	80/59	90/66	100/74
Intake Aspiration	Naturally Aspirated	Turbo	Naturally Aspirated	Turbo	Wastegate Turbo	Wastegate Turbo
Rated Speed	2250	2250	2200	2200	2200	2200
Max Torque Nm/ rpm	177/1200	222/1400	271/1400	325/1400	355/1400	402/1400
Torque Rise %	13	19	21	27	24	25
Optimum Fuel Consumption g/kw/h	214	216	214	217	216	210
Fuel Tank Capacity Ltr	155	155	155	155	155	155

Transmission

The fully synchromesh transmission used in these tractors has sixteen forward and eight reverse gears with a forward and reverse synchromesh shuttle and a two speed powershift. In addition the transmission is available as 30 or 40 Kph maximum speed and two or four wheel drive.

A dry single plate diaphragm clutch is used on all models.

PTO

The rear PTO drive is independent from the transmission drive and incorporates a hydraulically operated multiplate wet clutch. This clutch has the facility to feather the engagement of drive for smooth power take up.

The PTO options are single or double output shafts at 540/1000 rpm 6/21 splines or a shiftable single shaft 540/750 or 540/1000 rpm with 6 spline only.

Hydraulics

An engine driven steering pump supplies the steering, the transmission control circuits and the transmission pressure lubrication circuits. A large capacity pump supplies the hitch and auxiliary remote valves.

Up to three remote valves are available plus a power beyond facility.

The new top link sensing electronic hitch (EHC), features many of the features found on the Maxxum MX Series and Magnum tractors to give improved hitch performance.

Brakes

The tractors incorporate inboard wet disc brakes which are hydraulically operated and self adjusting.

A trailer brake valve is standard on some models and available as an option on all other models in the range.

Safety Cabs

The low profile cab provides a low height whilst retaining the comfort and similar specification to the delux version. Special features may include opening front windscreen and a roof window.

The delux cab which is available on all CX models is by design a luxury cab with many built in features. These include low noise down to 73dba on some models, free flow heating and ventilation, air conditioning (optional) and digital instrumentation.

LUBRICANTS AND CAPACITIES

Engine

Oil Type Case No.1 Engine Oil

Oil Capacity

CX50, CX60 -

Without Filter Change 6.75 Litres (1.78 US GAL)

With Filter Change 7.5 Litres (1.98 US GAL)

CX70, CX80, CX90, CX100 -

Without Filter Change 7.4 Litres (1.95 US GAL)

With Filter Change (With Turbo Charger) 8.5 Litres (2.25 US GAL)

With Filter Change (Without Turbo Charger) 8.2 Litres (2.16 US GAL)

NOTE: The oil level dipstick is ONLY a guide, when you fill the engine crankcase with oil. Always measure the amount of oil you install.

Cooling System

Coolant Mix Solution of 55% Water and 45% Ethylene Glycol

Coolant Capacity

CX50, CX60 11.4 Litres (3.01 US GAL)

CX70, CX80, CX90, CX100 13.7 Litres (3.62 US GAL)

Fuel Tank

Fuel Type No.2 Diesel Fuel

Fuel Tank Capacity 155 Litres (41 US GAL)

Transmission/Hydraulic System

Oil Type Case HY-TRAN PLUS ®

Refill Capacity

2WD approximately 34.5 Litres (9.11 US GAL)

MFD approximately 37.0 Litres (9.77 US GAL)

MFD Axle

Oil Type Case SAE 85W - 140 EP Gear Oil to API GL-5
or MIL-L-2105D Specification (MS 1316)

Axle Differential Capacity 5.0 Litres (1.32 US GAL)

Axle Planetary Capacity (EACH) 0.6 Litres (0.16 US GAL)

Front PTO

Oil Type Case HY-TRAN PLUS ®

Capacity 0.65 Litres (0.17 US GAL)

Section

2

ENGINE

How it Works

Engines

General

The engines used in these tractors are the 3 cylinder Case 900 Series and 4 cylinder 1000 Series which are available in naturally aspirated or turbocharged. These engines are produced in England and have many features that improve performance, reliability, service life and reduce maintenance and service costs.

Many of the components used in one engine are the same as those used in other engines of the range.

Most of the servicing procedures and specifications are the same throughout the engine range.

The CX50 and CX60 tractors use the three cylinder 900 Series and the CX70, CX80, CX90 and CX100 use the four cylinder 1000 Series engines.

Fuel System

The fuel tank capacity on all models is 155 Ltr and is pumped to the injection pump by an engine driven diaphragm lift pump. The CX50 and CX60 have a Lucas DP 202 injection pump and the CX70, CX80, CX90 and CX100 have a Lucas DP 203 injection pump.

The CX100 injection pump is also controlled by turbo boost pressure.

All pumps have an electrically operated cold start device which advances the fuel timing when the temperature is low and returns the timing to the correct setting when the temperature increases.

These pumps also have electrically operated fuel shut-off control and a self venting feature to aid venting the fuel system.

The fuel injectors have 5 hole nozzles and have a threaded gland type mounting.

Air Intake System

The engines in the CX50 and CX70 are naturally aspirated, the CX60 and CX80 engines are turbocharged, the engines in the CX90 and CX100 have Wastegate turbochargers.

Cooling System

The cooling system uses an in-line tube radiator with an aluminium core. The radiator can be repaired without specialist equipment. All the CX Series have the benefit of a Viscous fan for more efficient cooling and increased fuel economy.

The thermostat has a by-pass valve which allows all the engine coolant to circulate around the engine during warm up periods, this ensures a more even distribution of heat as the engine reaches its working temperature.

General Engine Specifications

MODELS	CX50	CX60	CX70	CX80	CX90	CX100
No. of Cyl	3	3	4	4	4	4
Cubic Capacity Litres/in ³	2.7/165	2.7/165	4.2/256	4.0/243	4.0/243	4.0/243
Bore/Stroke mm (ins)	95/127 (3.74/5.0)	95/127 (3.74/5.0)	103/127 (3.95/5.0)	100/127 (3.94/5.0)	100/127 (3.94/5.0)	100/127 (3.94/5.0)
Intake Aspiration	Naturally Aspirated	Turbo	Naturally Aspirated	Turbo	Wastegate Turbo	Wastegate Turbo
Max Power PS/KW	50/37	60/44	70/52	80/59	90/66	100/74
Rated Speed	2250	2250	2200	2200	2200	2200
High idle speed	2400	2400	2400	2400	2400	2400
Low idle speed	650-750	650-750	650-750	650-750	700-800	700-800
Max Torque Nm/ rpm	177/1200	222/1400	271/1400	325/1400	355/1400	402/1400
Torque Rise %	13	19	21	27	24	25
Optimum Fuel Consumption g/kw/h	214	216	214	217	216	210
Fuel Tank Capacity Ltr	155	155	155	155	155	155
Inj Pump - Lucas	DP202	DP202	DP203	DP203	DP203	DP203
Pump Timing °BTDC/RPM	2.5/2250	1.0/2250	0/2200	0/2200	0/2200	0/2200
Compression Ratio	17.5:1	17.5:1	17.25:1	17.25:1	17.25:1	17.25:1
Valve Clearance Inlet/Exh - cold mm(ins)	0.45/0.45 (0.008/ 0.018)	0.45/0.45 (0.008/ 0.018)	0.45/0.45 (0.008/ 0.018)	0.45/0.45 (0.008/ 0.018)	0.45/0.45 (0.008/ 0.018)	0.45/0.45 (0.008/ 0.018)

ENGINE REMOVAL AND INSTALLATION

CX50 and CX60 Tractors

NOTE: For Engine Installation, follow the Removal procedure in reverse order.

Before removing the Engine it will be necessary to carry out the following:

- Park the tractor on hard level ground and apply the parking brake.
- Lower the rear three point hitch.
- Stop the engine and remove the key.
- Put blocks in front of and behind the rear wheels.
- Remove the Front Hitch, if equipped, refer to Section 8011.
- Remove the Front PTO, if equipped, refer to Section 6015.
- Remove the front weights, if equipped.
- Remove the side panels and remove the hood.

STEP 1

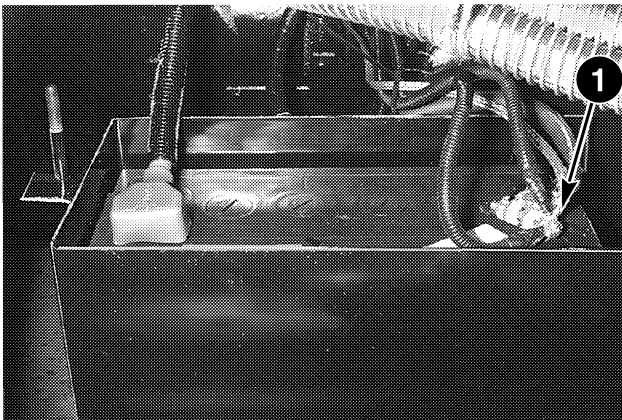

DD98B053

Disconnect the engine harness clean ground wire (1). Disconnect the battery, negative terminal (-) first. Lower the front cover on the battery box and remove the battery.

NOTE: For Installation, connect and tighten the positive (+) terminal first.

STEP 2 Tractors equipped with Air Conditioner

Refer to Section 9005, Air Conditioner System Component Servicing, and "Strip Away" the compressor, receiver/dryer and oil cooler/condenser. DO NOT disconnect the components.



WARNING: Never touch liquid refrigerant, since even a small drop on your skin will cause severe and painful frostbite. Always wear protective gloves.

SM114A



WARNING: Always wear safety goggles when working with liquid refrigerant. Liquid refrigerant in your eyes could cause blindness.

SM105A

STEP 3

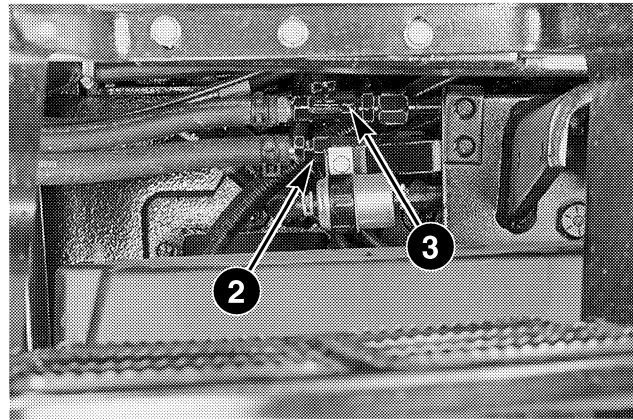

DP99J002

Close taps (2) and (3) on the heater hoses.

NOTE: DO NOT open the taps until Installation is complete, refer to Page 22, Filling the Cooling System.

STEP 4

Put suitable containers under the radiator and engine block drain plugs, remove the plugs and drain the cooling system.

NOTE: After draining the cooling system, install and tighten the drain plugs.

IMPORTANT: Dispose of drained coolant responsibly, DO NOT pour on the ground or into a drain. Be responsible for the environment.

STEP 5

Remove the MFD Axle, refer to Section 6021 or 2WD Front Axle, refer to Section 5003.

STEP 6

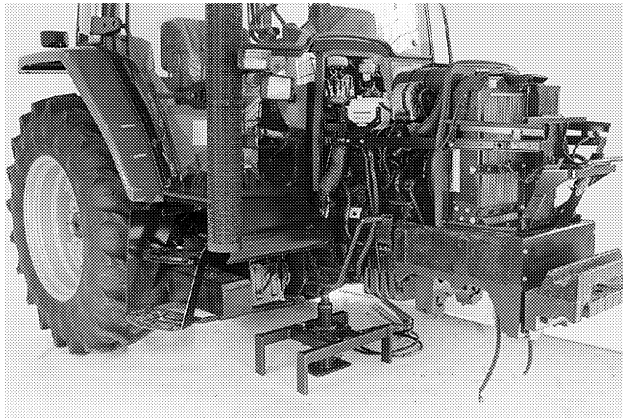

DP99J001

Support the tractor on a suitable stand under the speed transmission.

STEP 7

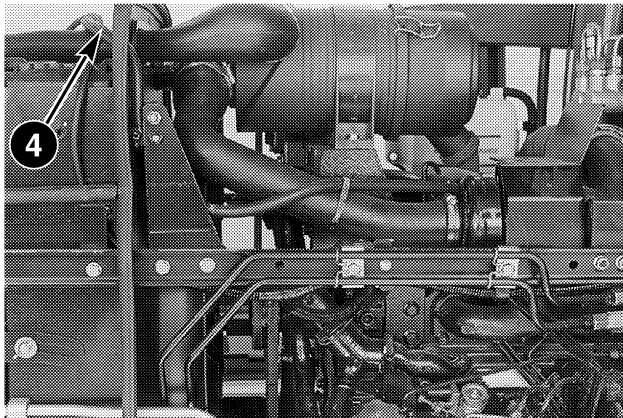

DP99J004

Remove the tie straps securing the overflow hose (4) to the air filter outlet tube and side rail bracket, remove the hose clip and disconnect overflow hose (4) from the radiator.

STEP 8

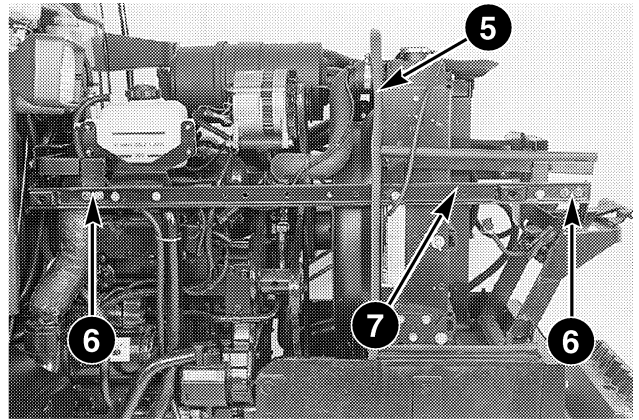

DP99J003

Remove rubber seal (5) from around the radiator shroud. Remove the tie strap securing the coolant recovery bottle overflow hose to the engine breather hose, remove nuts (6) and RH side rail (7).

NOTE: *It is not necessary to remove the coolant recovery bottle from the RH side rail (7).*

STEP 9

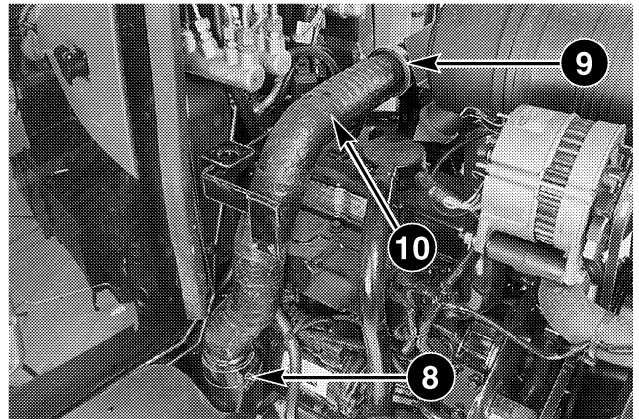

DP99J005

Loosen clamps (8) and (9) and remove exhaust pipe (10), cap the turbocharger outlet port and exhaust elbow.

STEP 10

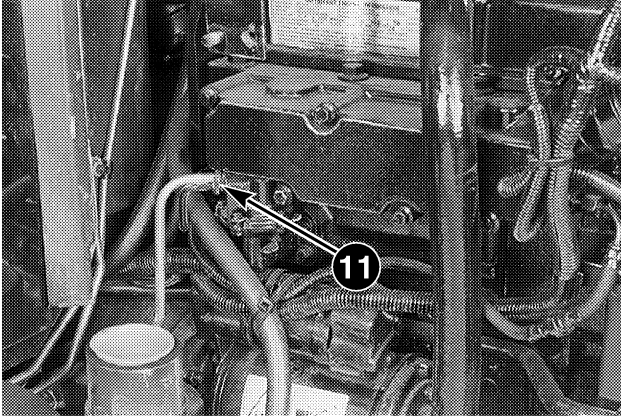

DP99J006

Disconnect and cap fuel supply tube (11) from the fuel lift pump.

STEP 11

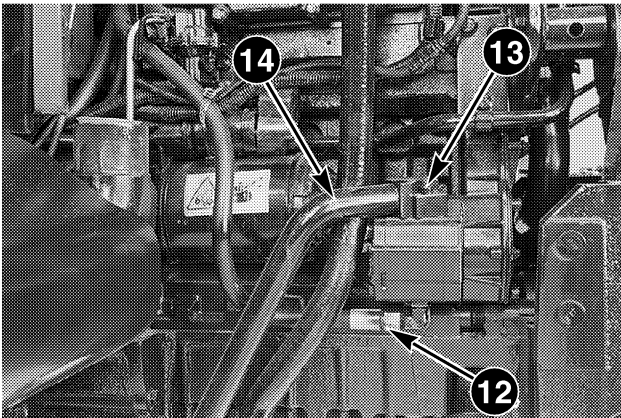

DP99J007

Put a suitable container under the steering hydraulic pump. Disconnect and cap the steering hand pump supply hose (12), remove retaining screws (13) and inlet tube (14), discard the o-ring and cap the fitting.

NOTE: For Installation, install a new o-ring on the inlet tube fitting.

STEP 12

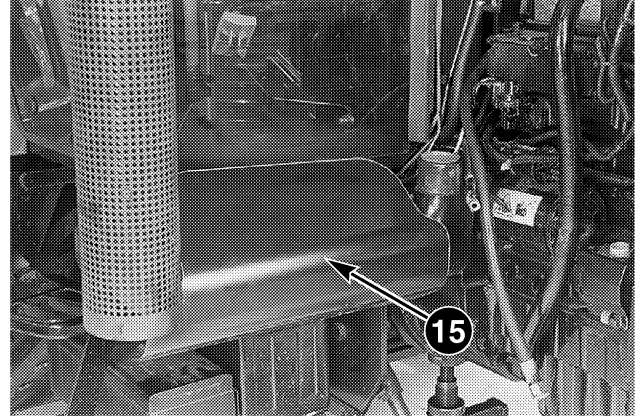

DP99J011

Remove three bolts, washers and exhaust manifold assembly (15).

STEP 13

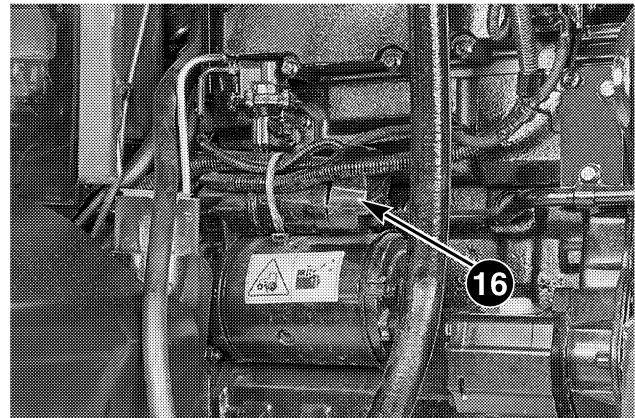

DP99J008

Remove the tie strap from around the starter solenoid. Remove cover (16) and disconnect the cables from the starter motor.

STEP 14

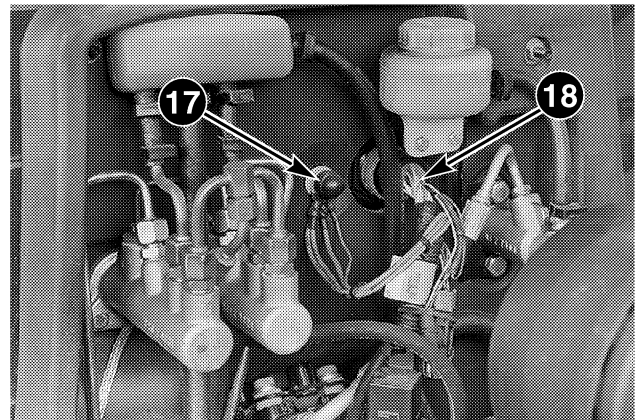

DP99J009

Disconnect the engine harness (17) and unswitched power cables (18) from the firewall.

STEP 15

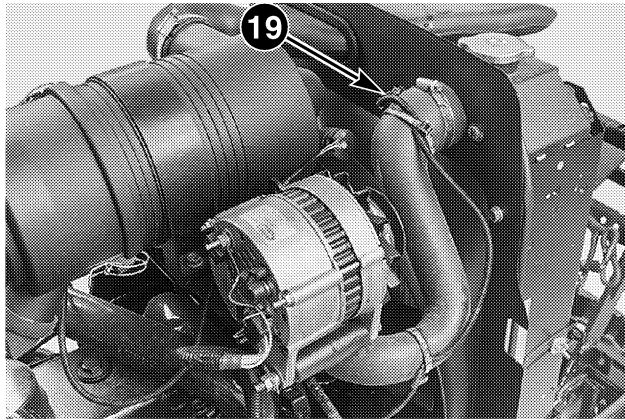

DP99J010

Remove the tie straps securing the coolant sender harness to the radiator top hose and disconnect the harness from the radiator coolant sender (19).

STEP 16

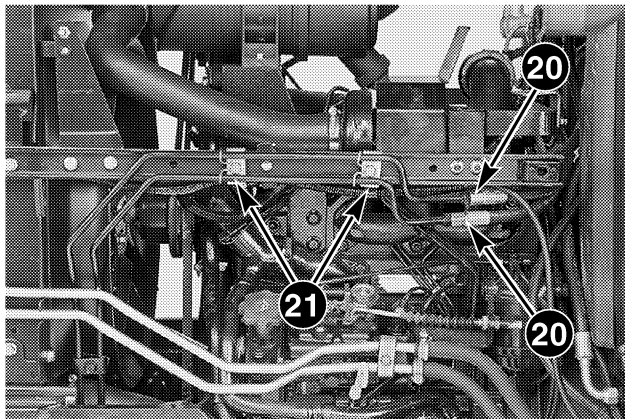

DP99J021

Disconnect and cap steering hoses (20), remove the clamps (21).

STEP 17

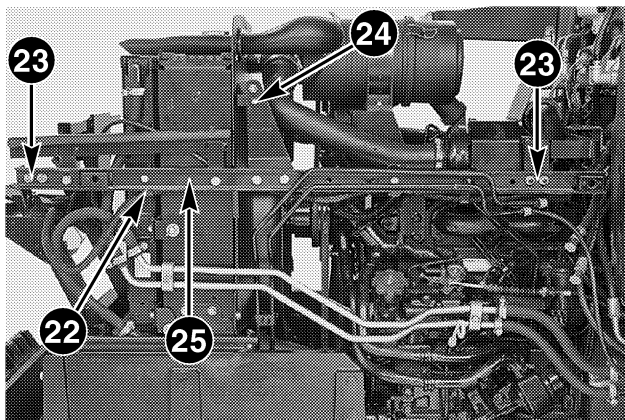

DP99J022

Disconnect the harness from the horn and remove from the clips on the front hood support bracket. Remove the harness from clamp (22). Remove nuts (23), bolt (24) and LH side rail (25).

STEP 18

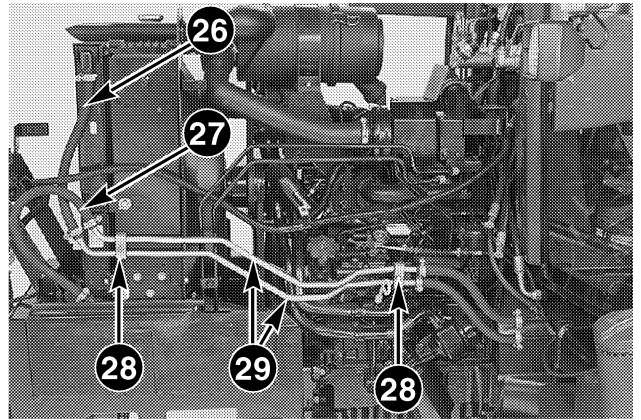

DP99J023

Disconnect oil cooler top hose (26) from the oil cooler and bottom hose (27) from the tube, cap the tubes and hoses. Remove clamps (28) and oil cooler tubes (29).

STEP 19

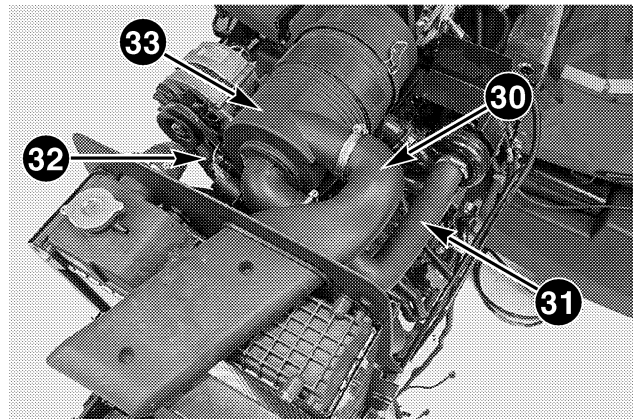

DP99J024

Loosen the clamps and remove the air filter intake tube (30) and outlet tube (31). Disconnect the harness from the air filter restriction switch (32). Remove retaining bolts and the air filter assembly (33), cap the turbocharger inlet port.

STEP 20

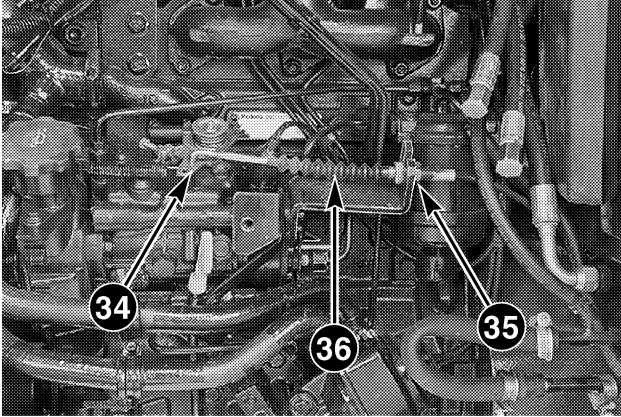

DP99J025

Remove the spring clip (34), loosen adjuster nuts (35) and remove throttle cable (36) from the bracket.

STEP 21

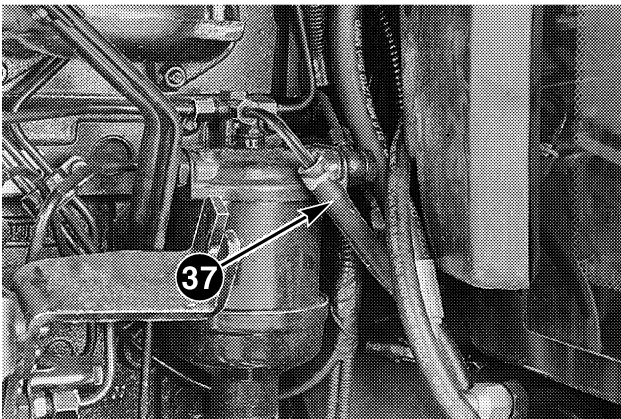

DP99J026

Disconnect and cap the fuel supply hose (37).

STEP 22

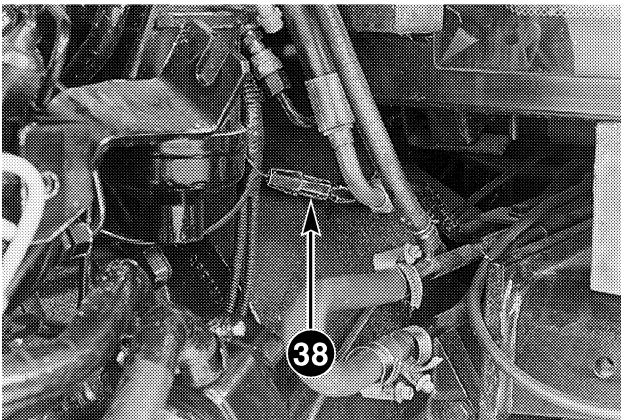

DP99J040

Disconnect the PTO neutral start connector (38).

STEP 23

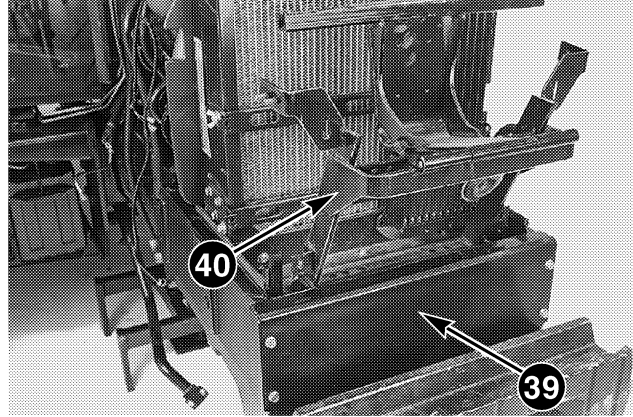

DP99J027

Remove the four retaining bolts and panel (39) from the front bolster. Remove the four retaining bolts and washers and front hood support bracket (40).

STEP 24

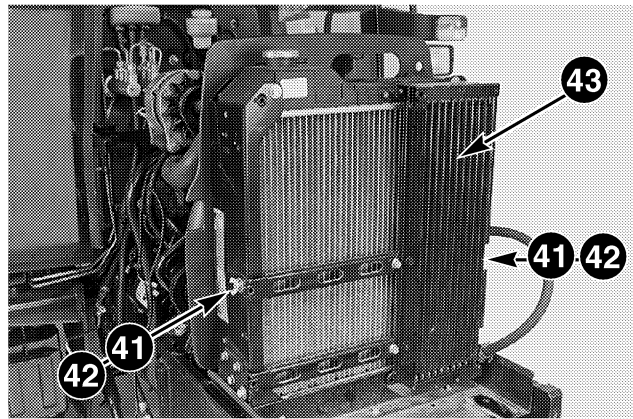

DP99J028

Remove retaining bolts (41), washers (42) and oil cooler (43).

STEP 25

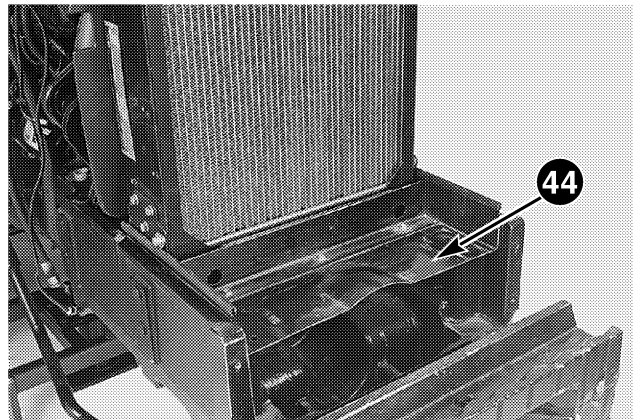

DP99J029

Remove the upper panel (44) from the front bolster.

STEP 26

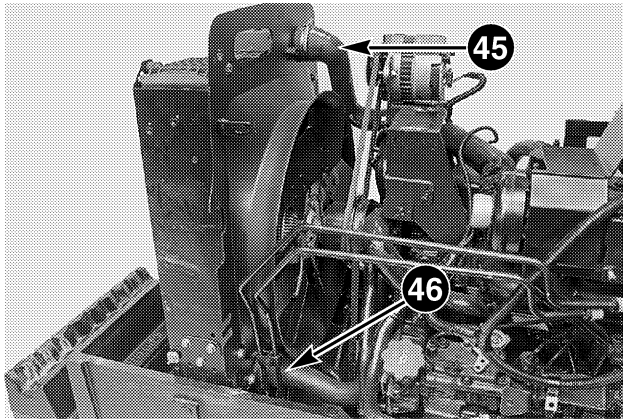

DP99J030

Loosen the clamps and remove the radiator top hose (45) and bottom hose (46).

STEP 27

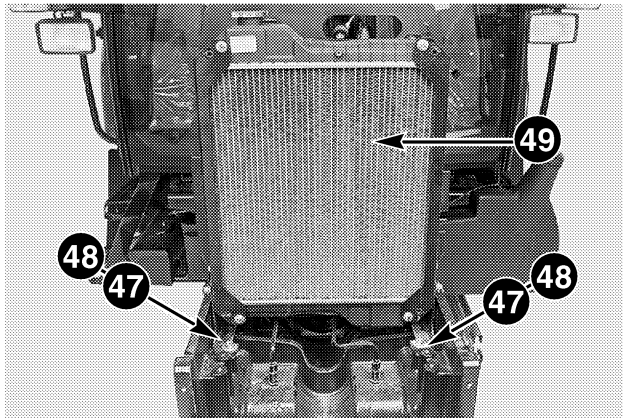

DP99J031

Remove four mounting bolts (47) and washers (48) (two are located as shown and two at the rear of the radiator), carefully remove the radiator.

STEP 28

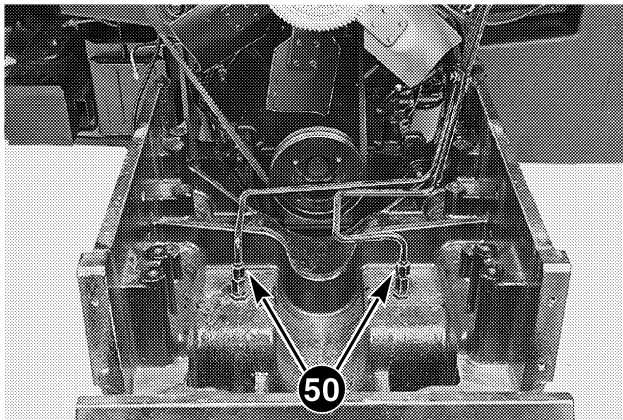

DP99J032

Remove and cap steering tubes (50).

STEP 29

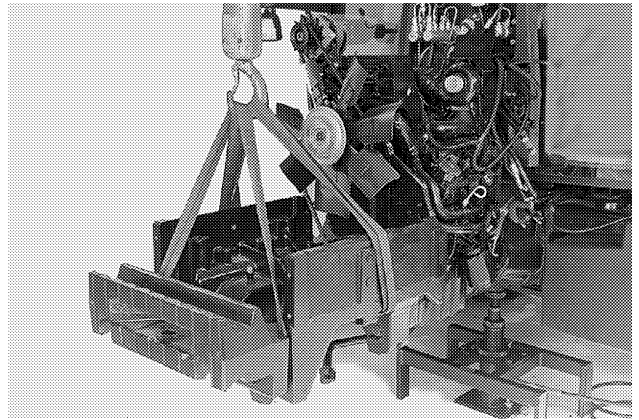

DP99J035

Attach suitable lifting equipment onto the front bolster.

STEP 30

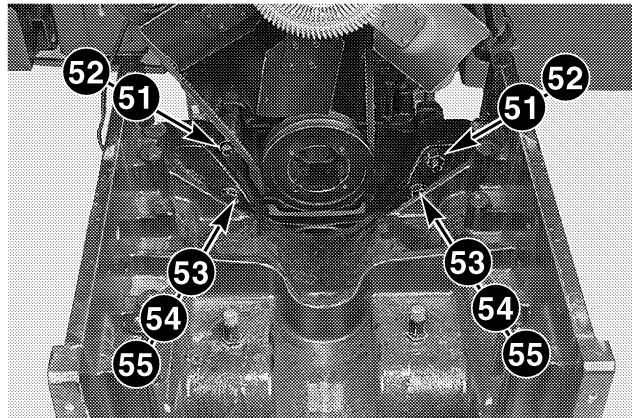

DP99J033

Remove two nuts (51) and washers (52) and two nuts (53), washers (54) and bolts (55).

NOTE: For Installation, apply Loctite 271 to the threads, install and tighten the nuts (51) and (53) to a torque of 258 to 284 Nm (190 to 210 lb ft).

NOTE: The front bolster upper mounting studs also have nuts (51) at the engine side of the stud, Loctite 271 must be applied to both threaded ends of the stud.

STEP 31

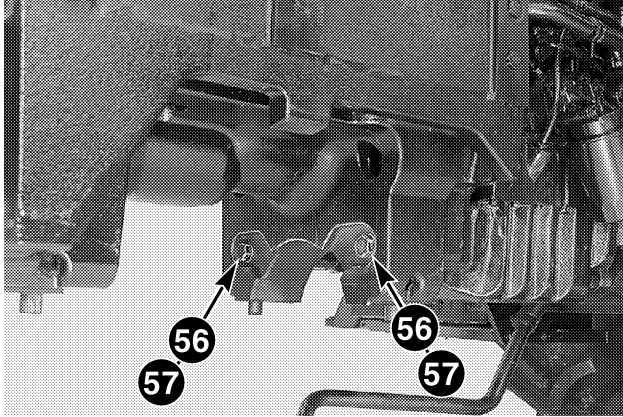

DP99J034

Remove two bolts (56) and washers (57). Carefully remove the front bolster.

NOTE: For Installation, make sure the bolster and engine mounting faces are clean and the locating dowels are in installed.

NOTE: For Installation, apply Loctite 271 to the threads, install and tighten the bolts (56) to a torque of 258 to 284 Nm (190 to 210 lb ft).

STEP 32

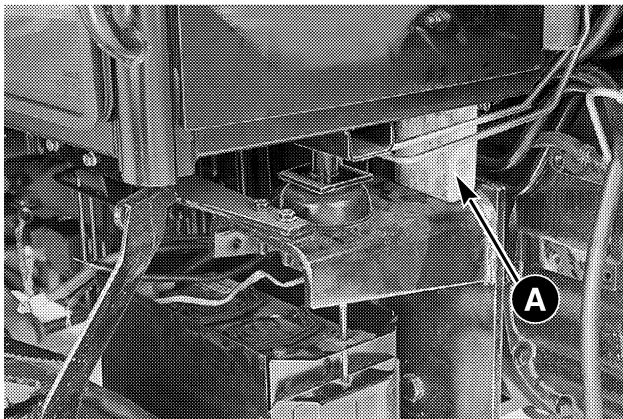

DP99J039

Remove the cab floor mat and remove the nuts and washers from the LH and RH front cab mountings. Install the front cab lifting brackets, from CAS2529, and suitable lifting equipment, slowly raise the front of the cab 40mm (1.5 inch) and install suitable blocks (A) between the cab and LH and RH mounting brackets, as shown. Lower the cab onto the blocks (A).

NOTE: For Installation, install and tighten the cab mounting nuts to a torque of 190 to 244 Nm (140 to 180 lb ft).

STEP 33

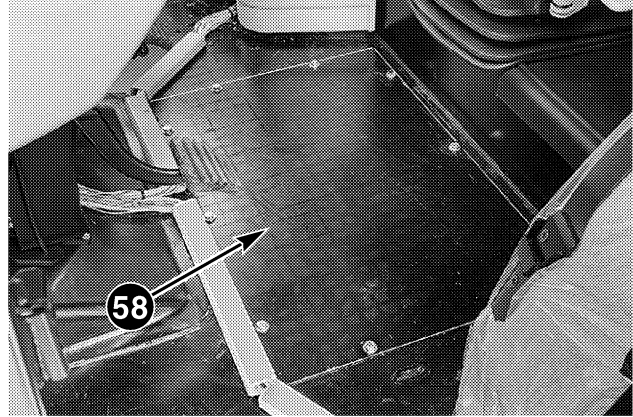

DP99G044

Remove the bolts and washers and remove cab floor panel (58) to gain access to the four upper transmission to engine mounting bolts.

STEP 34

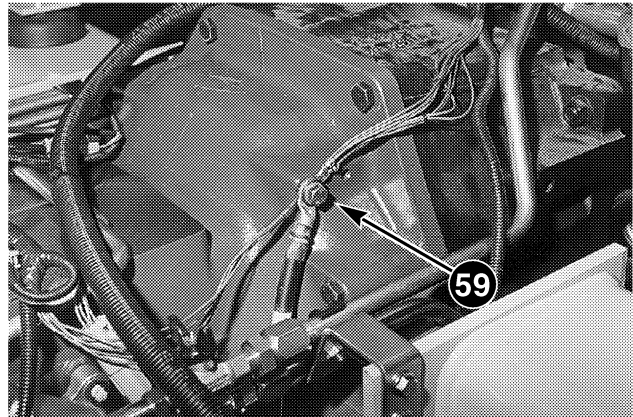

DP99G114

Remove bolt (59), battery negative cable, engine harness and transmission harness chassis ground connectors.

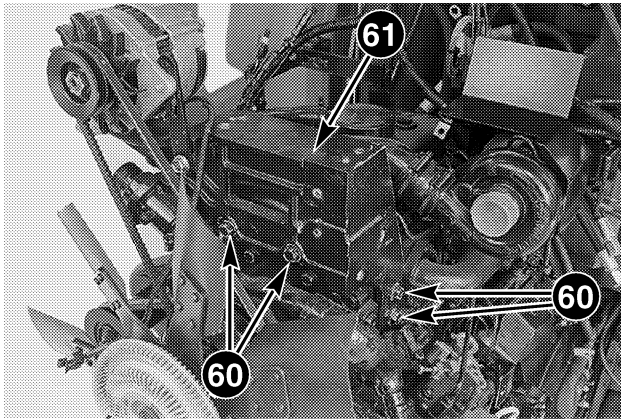
STEP 35

DP99J041

Disconnect the harness from the alternator, loosen the adjuster bolts and remove the drive belt. Remove four retaining bolts (60) and bracket (61).

NOTE: *It is not necessary to remove the alternator from bracket (61).*

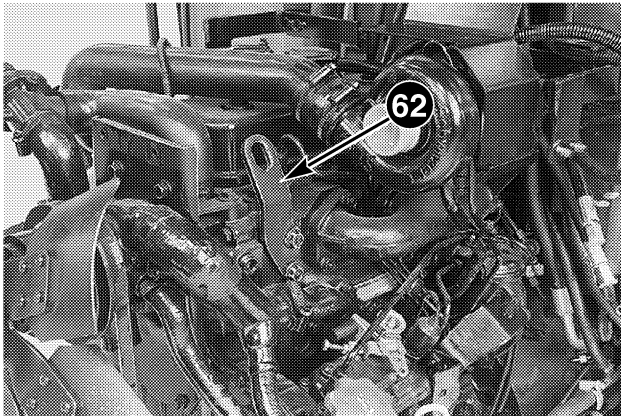
STEP 36

DP99J043

Install the front engine lifting bracket (62), install and tighten two 10 x 25 mm flange type bolts to a torque of 44 Nm (33 lb ft).

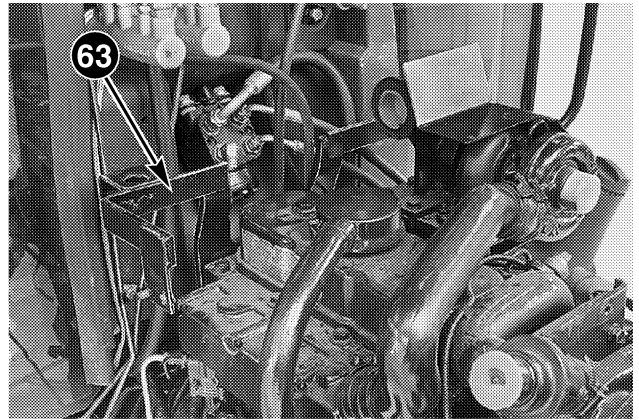
STEP 37

DP99J048

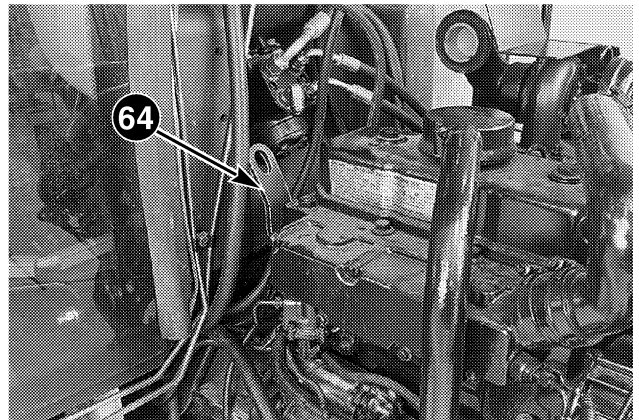

DP99J044

Remove the three retaining bolts and rear hood support bracket (63). Install the rear engine lifting bracket (64), install and tighten two 10 x 25 mm flange type bolts to a torque of 44 Nm (33 lb ft).

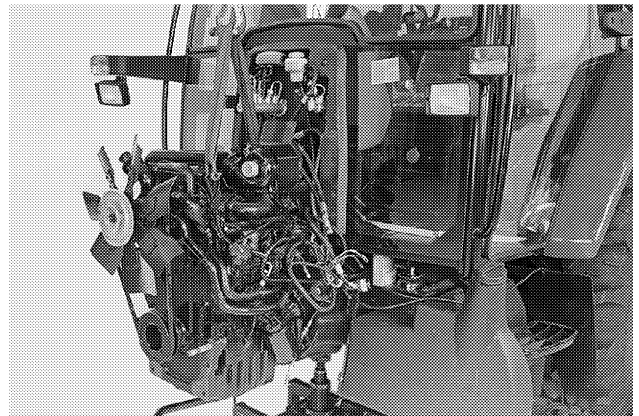
STEP 38

DP99J045

Attach suitable lifting equipment onto the engine as shown. Operate the lifting equipment until tension is just applied, **DO NOT LIFT** the tractor on the lifting equipment.

STEP 39

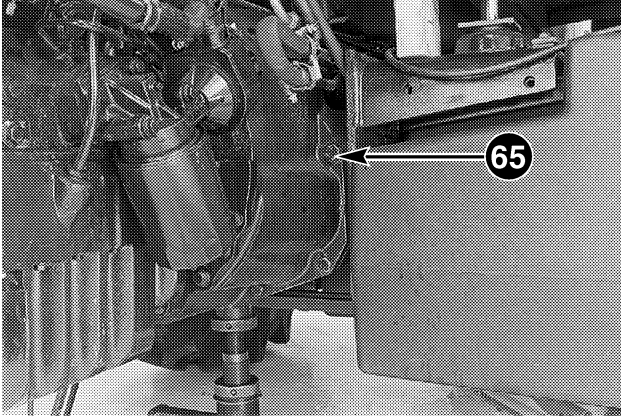

DP99J046

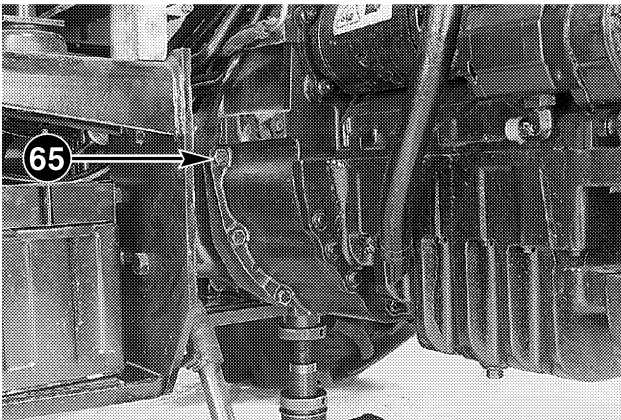

DP99J047

Remove engine to transmission retaining bolts (65) from both sides and install two alignment studs. Remove the remaining engine to transmission retaining bolts (65) from both sides.

NOTE: For Installation, tighten bolts (65) to a torque of 122 to 129 Nm (90 to 95 lb ft).

STEP 40

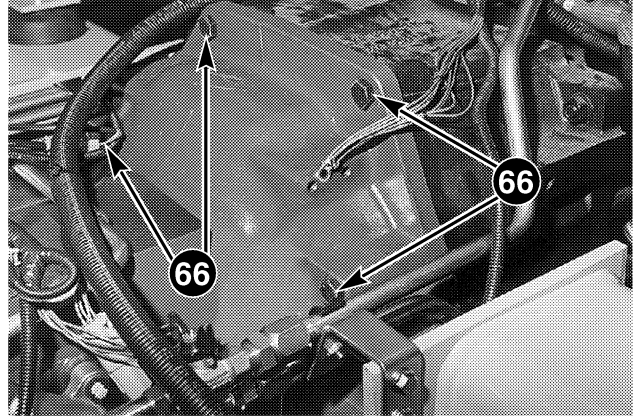

DR99G119

Remove the four upper transmission to engine retaining bolts (66), accessible through the floor panel removed in STEP 33.

NOTE: For Installation, tighten the bolts to a torque of 122 to 129 Nm (90 to 95 lb ft).

NOTE: The engine to transmission retaining bolts are of different lengths. Make a note of the position of the bolts when removing.

STEP 41

Carefully remove the engine, make sure all hoses, tubes, cables and harnesses and have been disconnected.

NOTE: DO NOT use excessive force when installing the engine onto the transmission.

NOTE: For Engine Installation, follow the Removal procedure in reverse order.

ENGINE REMOVAL AND INSTALLATION

CX70, CX80, CX90 and CX100 Tractors

NOTE: For Engine Installation, follow the Removal procedure in reverse order.

Before removing the Engine it will be necessary to carry out the following:

- Park the tractor on hard level ground and apply the parking brake.
- Lower the rear three point hitch.
- Stop the engine and remove the key.
- Put blocks in front of and behind the rear wheels.
- Remove the Front Hitch, if equipped, refer to Section 8011.
- Remove the Front PTO, if equipped, refer to Section 6015.
- Remove the front weights, if equipped.
- Remove the side panels and remove the hood.

STEP 1

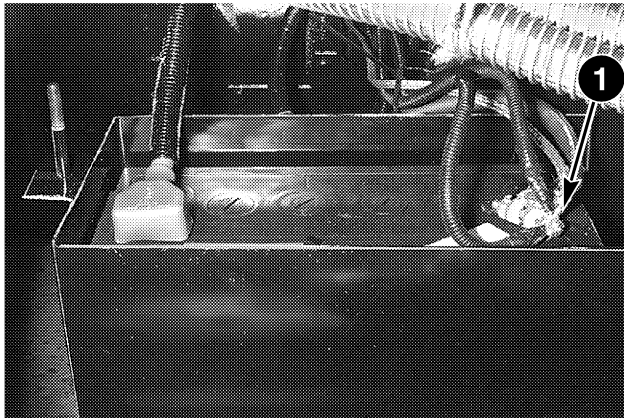

DD98B053

Disconnect the engine harness clean ground wire (1). Disconnect the battery, negative terminal (-) first. Lower the front cover on the battery box and remove the battery.

NOTE: For Installation, connect and tighten the positive (+) terminal first.

STEP 2 Tractors equipped with Air Conditioner

Refer to Section 9005, Air Conditioner System Component Servicing, and “Strip Away” the compressor, receiver/dryer and oil cooler/condenser. DO NOT disconnect the components.



WARNING: Never touch liquid refrigerant, since even a small drop on your skin will cause severe and painful frostbite. Always wear protective gloves. SM114A



WARNING: Always wear safety goggles when working with liquid refrigerant. Liquid refrigerant in your eyes could cause blindness. SM105A

STEP 3

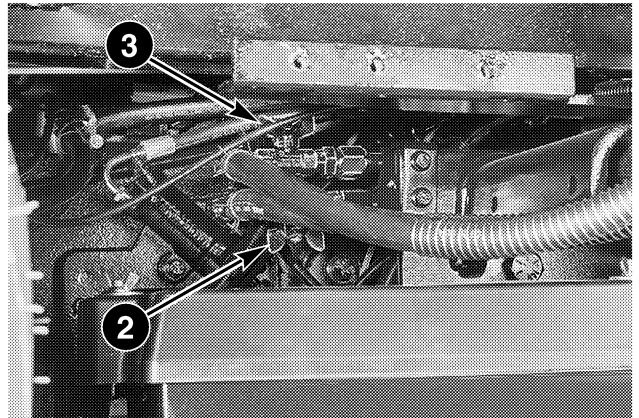

DP99F142

Close the taps (2) and (3) on the heater hoses.

NOTE: DO NOT open the taps until Installation is complete, refer to Page 22, Filling the Cooling System.

STEP 4

Put suitable containers under the radiator and engine block drain plugs, remove the plugs and drain the cooling system.

NOTE: After draining the cooling system, install and tighten the drain plugs.

IMPORTANT: Dispose of drained coolant responsibly, DO NOT pour on the ground or into a drain. Be responsible for the environment.

STEP 5

Remove the MFD Axle, refer to Section 6021 or 2WD Front Axle, refer to Section 5003.

STEP 6

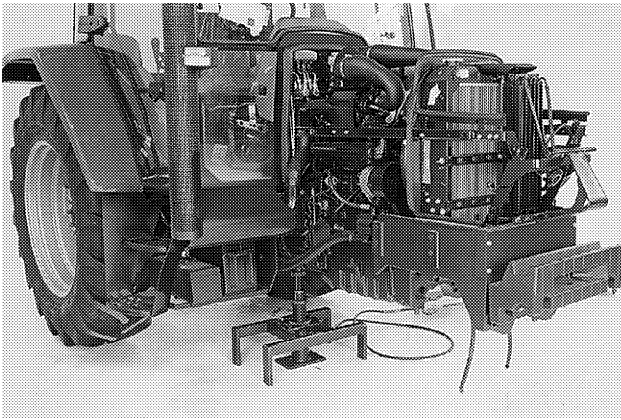

DP99G020

Support the tractor on a suitable stand under the speed transmission.

STEP 7

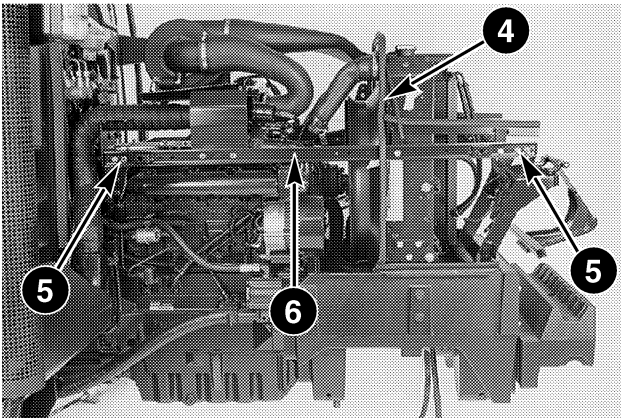

DP99G019

Remove rubber seal (4) from around the radiator shroud. Remove nuts (5) and RH side rail (6).

STEP 8

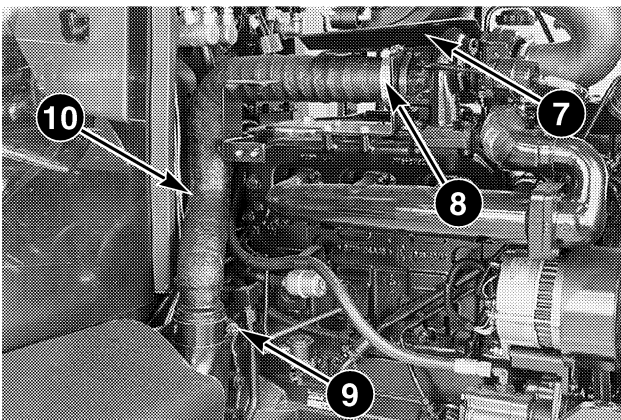

DP99G021

Remove the four retaining bolts and turbocharger heat shield (7). Loosen clamps (8) and (9) and remove exhaust pipe (10), cap the turbocharger outlet port and exhaust elbow.

STEP 9

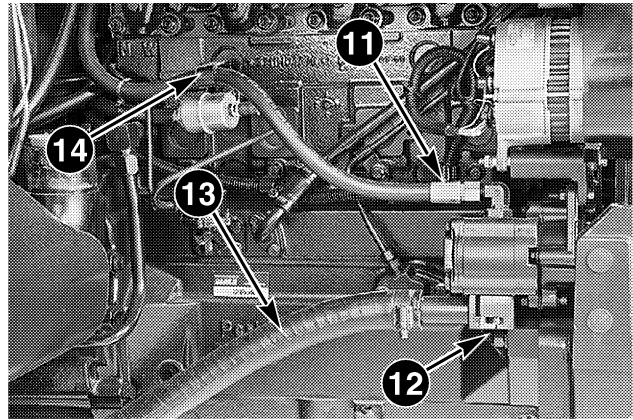

DP99G022

Put a suitable container under the steering hydraulic pump. Disconnect and cap the steering hand pump supply hose (11), remove retaining screws (12) and inlet hose (13), discard the o-ring and cap the fitting. Remove hose (11) from clamp (14).

NOTE: For Installation, install a new o-ring on the inlet hose fitting.

STEP 10

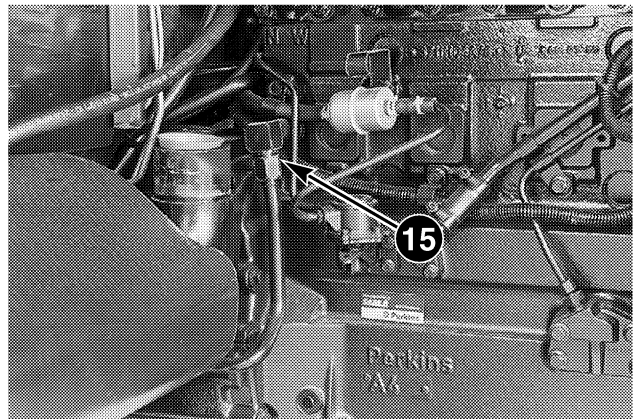

DP99G024

Disconnect and cap the heater feed tube (15).

STEP 11

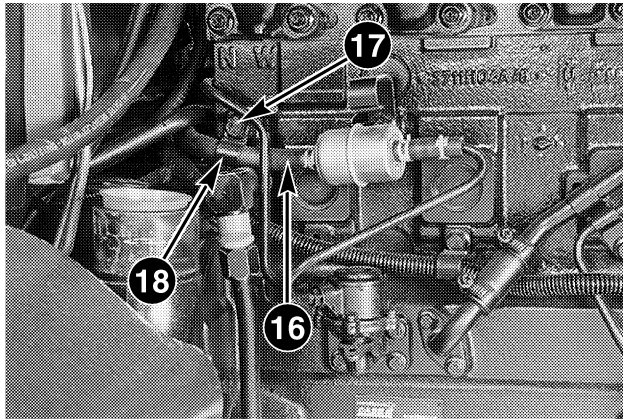

DP99G023

Disconnect and cap the fuel supply hose (16), remove bolt (17) and clamp (18).

STEP 12

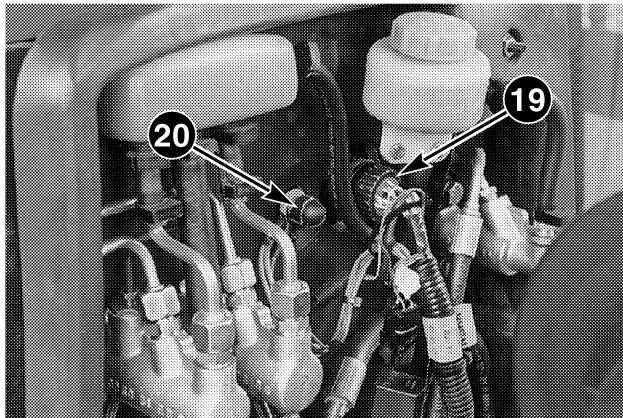

DP99G025

Disconnect the engine harness (19) and unswitched power cables (20) from the firewall.

STEP 13

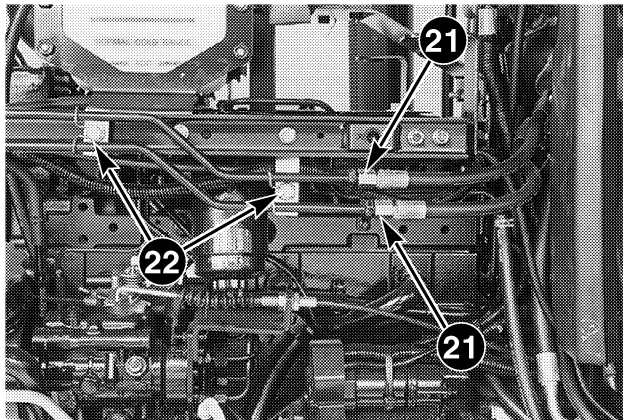

DP99G026

Disconnect and cap steering hoses (21), remove clamps (22).

STEP 14

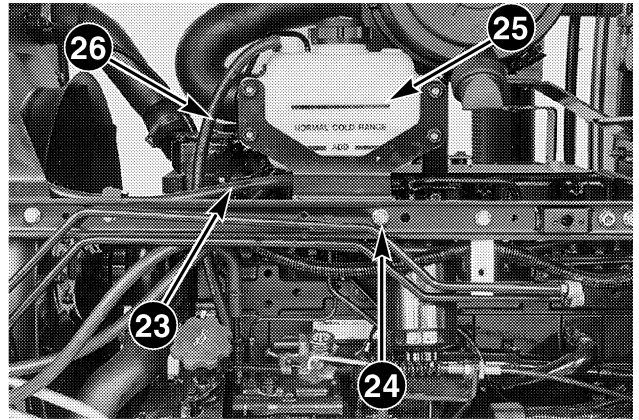

DP99G027

Disconnect and cap hose (23), remove retaining bolt (24) and coolant recovery bottle (25).

STEP 15

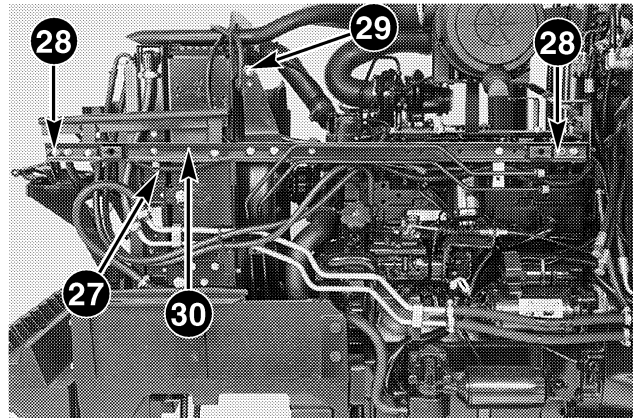

DP99G028

Disconnect the harness from the horn and remove from the clips on the front hood support bracket. Remove the harness from clamp (27). Remove nuts (28), bolt (29) and LH side rail (30).

STEP 16

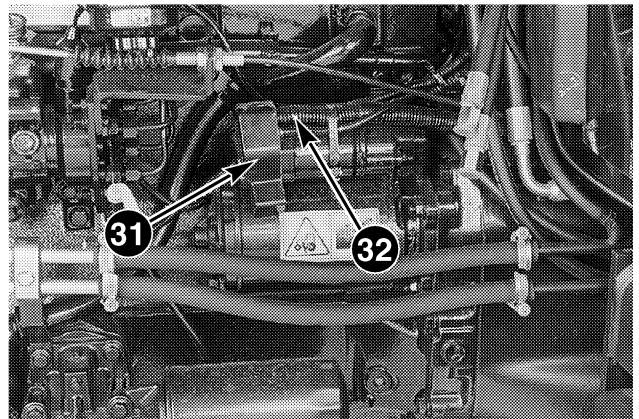

DP99G030

Remove the tie strap from around the starter solenoid. Remove cover (31) and disconnect cables (32) from the starter motor.

STEP 17

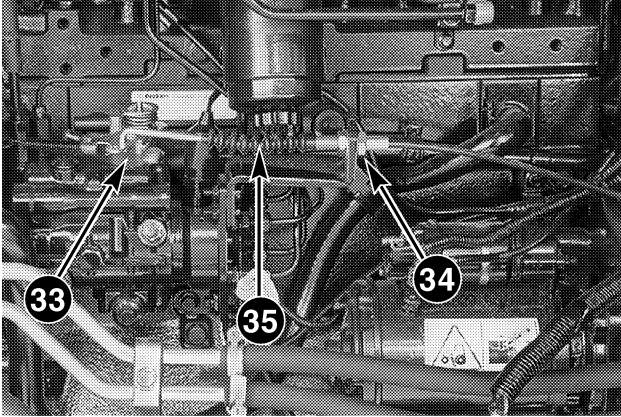

DP99G031

Remove spring clip (33), loosen adjuster nuts (34) and remove throttle cable (35) from the bracket.

STEP 18

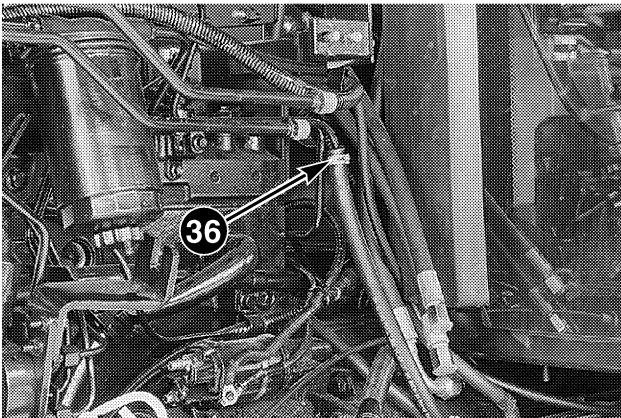

DP99G032

Disconnect and cap the fuel supply hose (36).

STEP 19

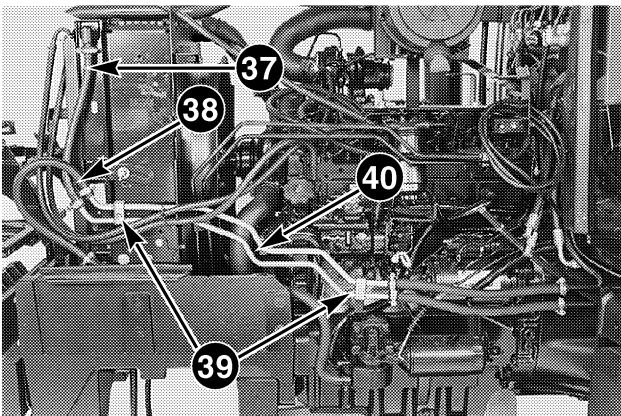

DP99G029

Disconnect oil cooler top hose (37) from the oil cooler and bottom hose (38) from the tube, cap the tubes and hoses. Remove clamps (39) and oil cooler tubes (40).

STEP 20

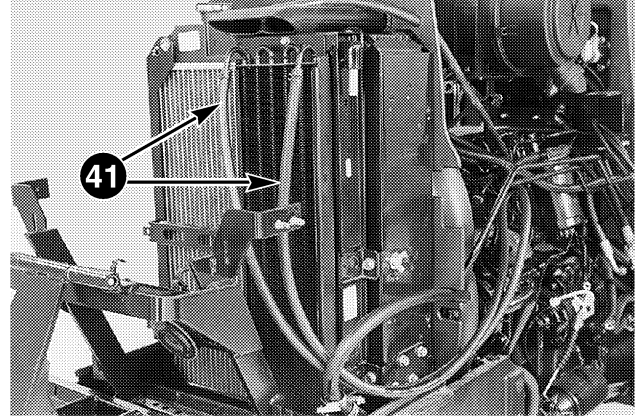

DP99G033

Disconnect and cap fuel cooler hoses (41), connect a suitable length of hose between the fuel cooler inlet and outlet tubes and secure with hose clips.

STEP 21

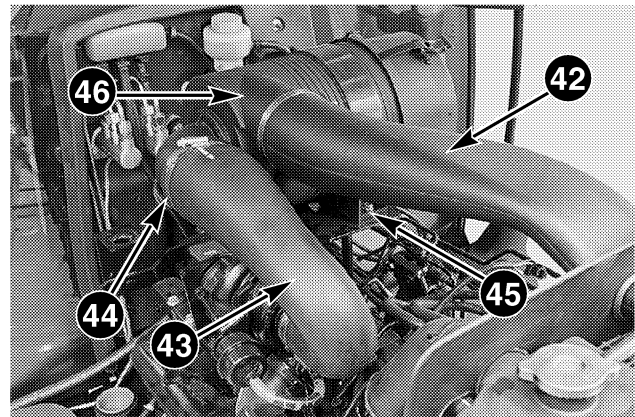

DP99G034

Loosen the clamps and remove the air filter intake tube (42) and outlet tube (43). Disconnect the harness from the air filter restriction switch (44). Remove retaining bolts (45) and the air filter assembly (46), cap the turbocharger inlet port.



Suggest:

If the above button click is invalid.

Please download this document

first, and then click the above link

to download the complete manual.

Thank you so much for reading

STEP 22

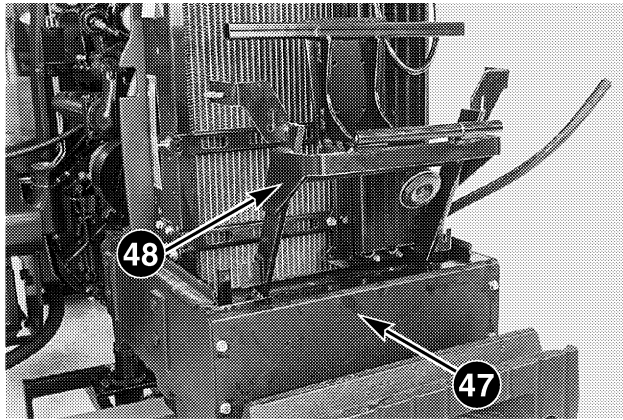

DP99G035

Remove the retaining bolts and panel (47) from the front bolster. Remove the four retaining bolts and washers and front hood support bracket (48).

STEP 23

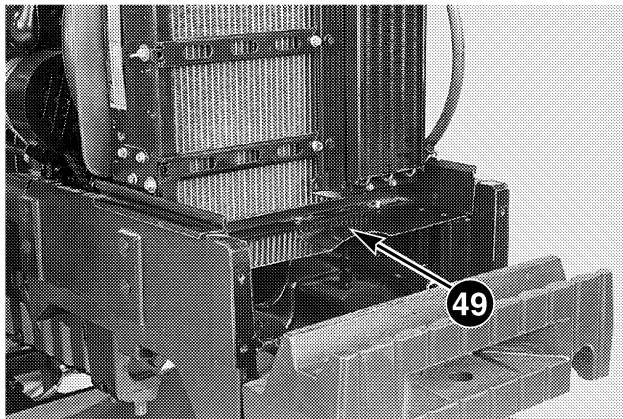

DP99G036

Remove the upper panel (49) from the front bolster.

STEP 24

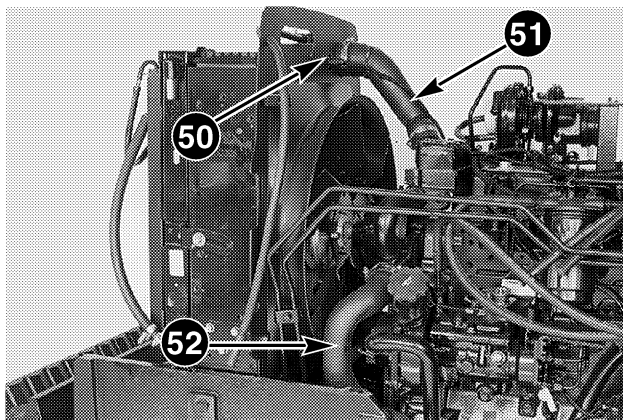

DP99G037

Remove the tie straps securing the coolant sender harness to the radiator top hose and disconnect the harness from the radiator coolant sender (50). Loosen the clamps and remove the top radiator hose (51) and bottom radiator hose (52).

STEP 25

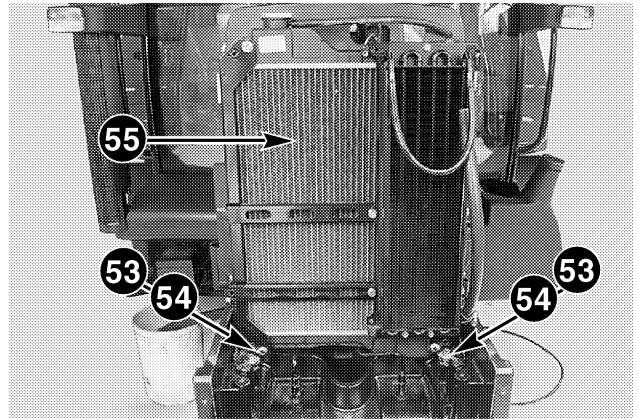

DP99G038

Remove four mounting bolts (53) and washers (54), (two are located as shown and two at the rear of the radiator), carefully remove the radiator (55).

STEP 26

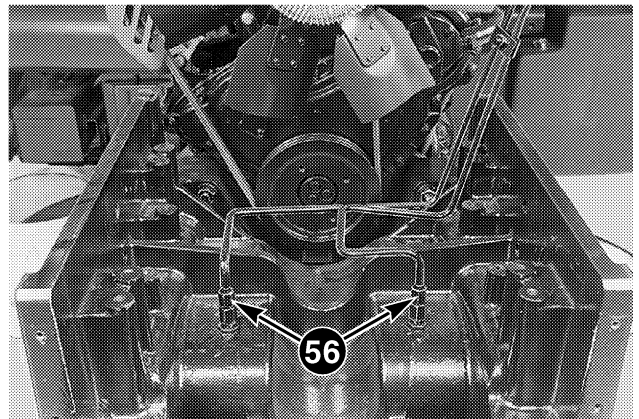

DP99G039

Remove and cap steering tubes (56).

STEP 27

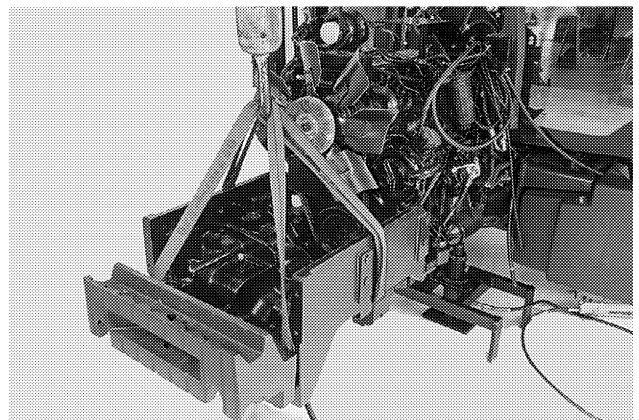

DP99G040

Attach suitable lifting equipment onto the front bolster.

<https://www.ebooklibonline.com>

Hello dear friend!

Thank you very much for reading.

Enter the link into your browser.

The full manual is available for immediate download.

<https://www.ebooklibonline.com>