

AXIAL-FLOW[®] 7240
AXIAL-FLOW[®] 8240
AXIAL-FLOW[®] 9240
Tier 4B (final)
Combine

SERVICE MANUAL

Part number 47800118

1st edition English

November 2014

Copyright © 2014 CNH Industrial America LLC. All Rights Reserved.



Link Product / Engine

| Product | Market Product | Engine |
|--|-----------------------|----------------|
| AXIAL-FLOW® 7240 Tier 4b engine, for European market | Europe | F3GFE613A*B001 |
| AXIAL-FLOW® 8240 Tier 4b engine, for EU market | Europe | F3HFE613A*B003 |
| AXIAL-FLOW® 9240 Tier 4b engine, for EU market | Europe | F3JFE613A*B001 |

Contents

INTRODUCTION

| | |
|---|-----------|
| Engine | 10 |
| [10.001] Engine and crankcase | 10.1 |
| [10.202] Air cleaners and lines | 10.2 |
| [10.210] Lift pump and lines | 10.3 |
| [10.216] Fuel tanks | 10.4 |
| [10.254] Intake and exhaust manifolds and muffler | 10.5 |
| [10.310] Aftercooler..... | 10.6 |
| [10.400] Engine cooling system | 10.7 |
| [10.414] Fan and drive | 10.8 |
| [10.418] Rotary screen | 10.9 |
| [10.419] Stationary air screen | 10.10 |
| [10.450] Engine air compressor | 10.11 |
| [10.500] Selective Catalytic Reduction (SCR) exhaust treatment..... | 10.12 |
| Main gearbox and drive | 14 |
| [14.100] Main gearbox and drive | 14.1 |
| Transmission | 21 |
| [21.100] Mechanical transmission lubrication system | 21.1 |
| [21.114] Mechanical transmission | 21.2 |
| [21.130] Mechanical transmission external controls..... | 21.3 |
| [21.145] Gearbox internal components..... | 21.4 |
| [21.182] Differential..... | 21.5 |
| Front axle system | 25 |
| [25.100] Powered front axle | 25.1 |
| [25.108] Final drive hub, steering knuckles, and shafts | 25.2 |
| [25.310] Final drives | 25.3 |

<https://www.ebooklibonline.com>

Hello dear friend!

Thank you very much for reading.

Enter the link into your browser.

The full manual is available for immediate download.

<https://www.ebooklibonline.com>

| | |
|---|-----------|
| Rear axle system | 27 |
| [27.100] Powered rear axle..... | 27.1 |
| [27.124] Final drive hub, steering knuckles, and shafts | 27.2 |
| [27.550] Non-powered rear axle..... | 27.3 |
| Hydrostatic drive | 29 |
| [29.100] Transmission and steering hydrostatic control | 29.1 |
| [29.202] Hydrostatic transmission | 29.2 |
| [29.218] Pump and motor components..... | 29.3 |
| [29.300] Rear hydrostatic transmission..... | 29.4 |
| Brakes and controls | 33 |
| [33.110] Parking brake or parking lock | 33.1 |
| [33.202] Hydraulic service brakes | 33.2 |
| Hydraulic systems | 35 |
| [35.000] Hydraulic systems..... | 35.1 |
| [35.102] Pump control valves..... | 35.2 |
| [35.106] Variable displacement pump | 35.3 |
| [35.220] Auxiliary hydraulic pump and lines | 35.4 |
| [35.300] Reservoir, cooler, and filters..... | 35.5 |
| [35.350] Safety and main relief valves | 35.6 |
| [35.359] Main control valve..... | 35.7 |
| [35.440] Grain tank unload system | 35.8 |
| [35.518] Reel control system | 35.9 |
| [35.536] Crop processor system | 35.10 |
| [35.752] Hydraulic fan drive cooling system..... | 35.11 |
| Steering | 41 |
| [41.101] Steering control | 41.1 |
| [41.200] Hydraulic control components..... | 41.2 |
| [41.216] Cylinders | 41.3 |

| | |
|---|-----------|
| [41.432] Autoguidance steering | 41.4 |
| Wheels | 44 |
| [44.511] Front wheels | 44.1 |
| Tracks and track suspension | 48 |
| [48.100] Tracks | 48.1 |
| [48.130] Track frame and driving wheels | 48.2 |
| [48.134] Track tension units | 48.3 |
| [48.138] Track rollers | 48.4 |
| Cab climate control | 50 |
| [50.100] Heating | 50.1 |
| [50.104] Ventilation | 50.2 |
| [50.200] Air conditioning | 50.3 |
| Electrical systems | 55 |
| [55.000] Electrical system | 55.1 |
| [55.050] Heating, Ventilation, and Air-Conditioning (HVAC) control system | 55.2 |
| [55.100] Harnesses and connectors | 55.3 |
| [55.201] Engine starting system | 55.4 |
| [55.421] Feeding control system | 55.5 |
| [55.426] Harvest material flow control system | 55.6 |
| [55.628] Threshing electrical control | 55.7 |
| [55.780] Shaker shoe leveling system control | 55.8 |
| [55.988] Selective Catalytic Reduction (SCR) electrical system | 55.9 |
| [55.DTC] FAULT CODES | 55.10 |
| Product feeding | 60 |
| [60.105] Floating roll, feed chain, and drive | 60.1 |
| [60.110] Feeder housing | 60.2 |
| [60.112] Stone trapping system | 60.3 |
| [60.150] Feeder drive system | 60.4 |

| | |
|---|-----------|
| Threshing | 66 |
| [66.000] Threshing | 66.1 |
| [66.101] Concave conveyor plate | 66.2 |
| [66.110] Concave control system..... | 66.3 |
| [66.260] Threshing mechanism drive system | 66.4 |
| [66.331] Rotor | 66.5 |
| Separation | 72 |
| [72.430] Separator grates | 72.1 |
| Residue handling | 73 |
| [73.210] Straw chopper drive system..... | 73.1 |
| [73.215] Straw chopper electro-magnetic clutch support..... | 73.2 |
| [73.230] Straw chopper..... | 73.3 |
| [73.430] Straw spreader | 73.4 |
| Crop storage / Unloading | 80 |
| [80.101] Clean grain elevator..... | 80.1 |
| [80.150] Grain tank | 80.2 |
| [80.175] Grain tank unload drive system | 80.3 |
| [80.180] Grain tank unload | 80.4 |
| Platform, cab, bodywork, and decals | 90 |
| [90.100] Engine hood and panels | 90.1 |
| [90.105] Machine shields and guards | 90.2 |
| [90.150] Cab..... | 90.3 |



INTRODUCTION

Foreword - Important notice regarding equipment servicing

| | |
|------------------|----|
| AXIAL-FLOW® 7240 | WE |
| AXIAL-FLOW® 8240 | WE |
| AXIAL-FLOW® 9240 | WE |

All repair and maintenance work listed in this manual must be carried out only by qualified dealership personnel, strictly complying with the instructions given, and using, whenever possible, the special tools.

Anyone who performs repair and maintenance operations without complying with the procedures provided herein shall be responsible for any subsequent damages.

The manufacturer and all the organizations of its distribution chain, including - without limitation - national, regional, or local dealers, reject any responsibility for damages caused by parts and/or components not approved by the manufacturer, including those used for the servicing or repair of the product manufactured or marketed by the manufacturer. In any case, no warranty is given or attributed on the product manufactured or marketed by the manufacturer in case of damages caused by parts and/or components not approved by the manufacturer.

The manufacturer reserves the right to make improvements in design and changes in specifications at any time without notice and without incurring any obligation to install them on units previously sold. Specifications, descriptions, and illustrative material herein are as accurate as known at time of publication but are subject to change without notice.

In case of questions, refer to your CASE IH Sales and Service Networks.

Basic instructions - Important notice regarding equipment servicing

| | |
|------------------|----|
| AXIAL-FLOW® 7240 | WE |
| AXIAL-FLOW® 8240 | WE |
| AXIAL-FLOW® 9240 | WE |

All repair and maintenance work listed in this manual must be carried out only by qualified dealership personnel, strictly complying with the instructions given, and using, whenever possible, the special tools.

Anyone who performs repair and maintenance operations without complying with the procedures provided herein shall be responsible for any subsequent damages.

The manufacturer and all the organizations of its distribution chain, including - without limitation - national, regional, or local dealers, reject any responsibility for damages caused by parts and/or components not approved by the manufacturer, including those used for the servicing or repair of the product manufactured or marketed by the manufacturer. In any case, no warranty is given or attributed on the product manufactured or marketed by the manufacturer in case of damages caused by parts and/or components not approved by the manufacturer.

The information in this manual is up-to-date at the date of the publication. It is the policy of the manufacturer for continuous improvement. Some information could not be updated due to modifications of a technical or commercial type, or changes to the laws and regulations of different countries.

In case of questions, refer to your CASE IH Sales and Service Networks.

Safety rules

AXIAL-FLOW® 40 Series

WE

Personal safety





This is the safety alert symbol. It is used to alert you to potential personal injury hazards. Obey all safety messages that follow this symbol to avoid possible death or injury.

Throughout this manual you will find the signal words DANGER, WARNING, and CAUTION followed by special instructions. These precautions are intended for the personal safety of you and those working with you.

Read and understand all the safety messages in this manual before you operate or service the machine.

 DANGER indicates a hazardous situation that, if not avoided, will result in death or serious injury.

 WARNING indicates a hazardous situation that, if not avoided, could result in death or serious injury.

 CAUTION indicates a hazardous situation that, if not avoided, could result in minor or moderate injury.

FAILURE TO FOLLOW DANGER, WARNING, AND CAUTION MESSAGES COULD RESULT IN DEATH OR SERIOUS INJURY.

Machine safety

NOTICE: Notice indicates a situation that, if not avoided, could result in machine or property damage.

Throughout this manual you will find the signal word Notice followed by special instructions to prevent machine or property damage. The word Notice is used to address practices not related to personal safety.

Information

NOTE: Note indicates additional information that clarifies steps, procedures, or other information in this manual.

Throughout this manual you will find the word Note followed by additional information about a step, procedure, or other information in the manual. The word Note is not intended to address personal safety or property damage.

Personal safety

AXIAL-FLOW® 40 Series

WE

⚠ WARNING

Risk of harm during maintenance of the machine!

Before you start servicing the machine, attach a DO NOT OPERATE warning tag to the machine in a visible area.

Failure to comply could result in death or serious injury.

W1242A

Attach a DO NOT OPERATE (TAG) to the machine in an area that is clearly visible whenever the machine is not operating properly and/or requires service.

Complete the tag information for the "REASON" the tag is attached by describing the malfunction or service required.

Validate the reason for attaching the tag by signing your name in the designated area on the tag.

The tag should only be removed by the person who signed and attached the tag, after validating the repairs or services have been completed.

Safety rules - Ecology and the environment

| | |
|------------------|----|
| AXIAL-FLOW® 7240 | WE |
| AXIAL-FLOW® 8240 | WE |
| AXIAL-FLOW® 9240 | WE |

Soil, air, and water quality is important for all industries and life in general. When legislation does not yet rule the treatment of some of the substances that advanced technology requires, sound judgment should govern the use and disposal of products of a chemical and petrochemical nature.

Familiarize yourself with the relative legislation applicable to your country, and make sure that you understand this legislation. Where no legislation exists, obtain information from suppliers of oils, filters, batteries, fuels, anti-freeze, cleaning agents, etc., with regard to the effect of these substances on man and nature and how to safely store, use, and dispose of these substances.

Helpful hints

- Avoid the use of cans or other inappropriate pressurized fuel delivery systems to fill tanks. Such delivery systems may cause considerable spillage.
- In general, avoid skin contact with all fuels, oils, acids, solvents, etc. Most of these products contain substances that may be harmful to your health.
- Modern oils contain additives. Do not burn contaminated fuels and or waste oils in ordinary heating systems.
- Avoid spillage when you drain fluids such as used engine coolant mixtures, engine oil, hydraulic fluid, brake fluid, etc. Do not mix drained brake fluids or fuels with lubricants. Store all drained fluids safely until you can dispose of the fluids in a proper way that complies with all local legislation and available resources.
- Do not allow coolant mixtures to get into the soil. Collect and dispose of coolant mixtures properly.
- The air-conditioning system contains gases that should not be released into the atmosphere. Consult an air-conditioning specialist or use a special extractor to recharge the system properly.
- Repair any leaks or defects in the engine cooling system or hydraulic system immediately.
- Do not increase the pressure in a pressurized circuit as this may lead to a component failure.
- Protect hoses during welding. Penetrating weld splatter may burn a hole or weaken hoses, allowing the loss of oils, coolant, etc.

Battery recycling

Batteries and electric accumulators contain several substances that can have a harmful effect on the environment if the batteries are not properly recycled after use. Improper disposal of batteries can contaminate the soil, groundwater, and waterways. CASE IH strongly recommends that you return all used batteries to a CASE IH dealer, who will dispose of the used batteries or recycle the used batteries properly. In some countries, this is a legal requirement.



Mandatory battery recycling

NOTE: The following requirements are mandatory in Brazil.

Batteries are made of lead plates and a sulfuric acid solution. Because batteries contain heavy metals such as lead, CONAMA Resolution 401/2008 requires you to return all used batteries to the battery dealer when you replace any batteries. Do not dispose of batteries in your household garbage.

Points of sale are obliged to:

- Accept the return of your used batteries
- Store the returned batteries in a suitable location
- Send the returned batteries to the battery manufacturer for recycling



SERVICE MANUAL

Engine

AXIAL-FLOW® 7240 Tier 4b engine, for European market
AXIAL-FLOW® 8240 Tier 4b engine, for EU market
AXIAL-FLOW® 9240 Tier 4b engine, for EU market

Engine - Remove

| | |
|------------------|----|
| AXIAL-FLOW® 7240 | WE |
| AXIAL-FLOW® 8240 | WE |

⚠ WARNING

Avoid injury! Always do the following before lubricating, maintaining, or servicing the machine.

1. Disengage all drives.
2. Engage parking brake.
3. Lower all attachments to the ground, or raise and engage all safety locks.
4. Shut off engine.
5. Remove key from key switch.
6. Switch off battery key, if installed.
7. Wait for all machine movement to stop.

Failure to comply could result in death or serious injury.

W0047A

⚠ WARNING

Heavy objects!

Lift and handle all heavy components using lifting equipment with adequate capacity. Always support units or parts with suitable slings or hooks. Make sure the work area is clear of all bystanders.

Failure to comply could result in death or serious injury.

W0398A

Prior operation:

Engine hood - Remove (90.105)

Prior operation:

Central wiring harness - Remove (55.100)

Prior operation:

Fan and drive - Remove (10.414)

Prior operation:

Air conditioning - Service instruction (50.200)

Prior operation:

Air intake system - Remove (10.202)

Prior operation:

Fuel supply lines Low pressure - Remove from the engine (10.210)

Prior operation:

Fuel return lines - Remove from the engine (10.210)

Prior operation:

Exhaust muffler - Remove mixer tube (10.254)

Prior operation:

Exhaust muffler - Remove exhaust tube from turbo charger to Diesel Oxidation Catalyst (DOC) (10.254)

Prior operation:

Aftercooler air supply and return lines - Remove air supply tube (10.310)

Prior operation:

Aftercooler air supply and return lines - Remove air return tube (10.310)

Prior operation:

Engine cooling system - Drain fluid (10.400)

Prior operation:

Radiator hoses - Remove (10.400)

Prior operation:

Deaeration tank - Remove (10.400)

Prior operation:

Selective Catalytic Reduction (SCR) exhaust treatment - Remove DEF hose bundle (10.500)

Prior operation:

Selective Catalytic Reduction (SCR) muffler and catalyst - Remove (10.500)

Prior operation:

Diesel Oxidation Catalyst (DOC) - Remove (10.500)

NOTE: Illustrations are for reference only. It may not be the actual engine.

1. Disengage the battery connect switch **(1)**.

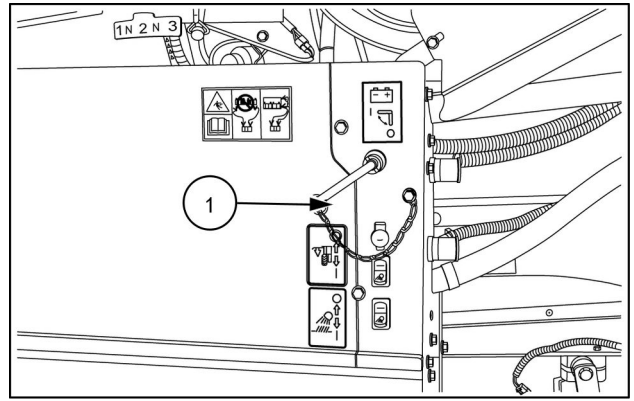

NHIL13AF00586AA 1

2. Attach a suitable lift chain to the front lift eye **(1)** at the front of the engine.

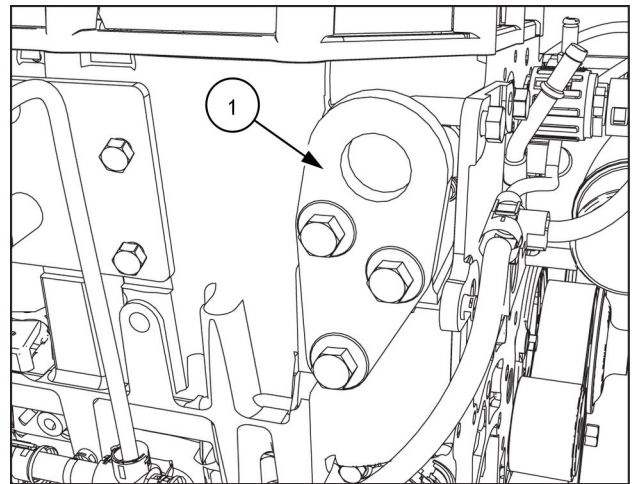

NHIL14AF00431AA 2

3. Attach a suitable lift chain to the back lift eye **(1)** at the rear of the engine.

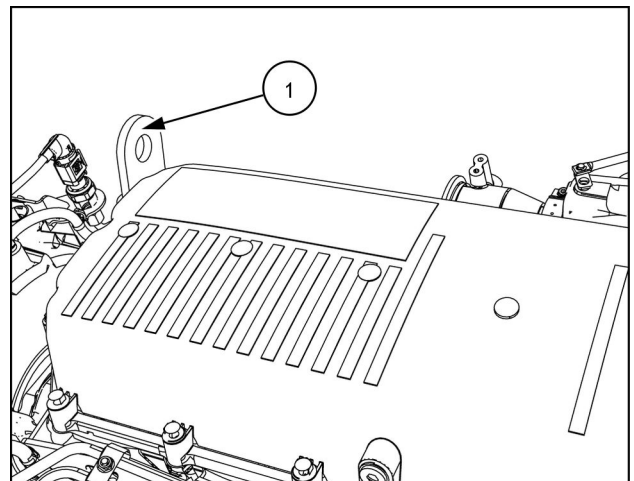

NHIL14AF00432AA 3

4. Connect the lift chain to a suitable lifting device.
5. Raise the lifting device enough to support the engine during removal of the engine mounting bolts.

NOTE: The lifting device should be rated for at least **907.2 kg (2000 lb)**. Allow enough clearance to lift the engine from the combine, approximately **7.0 m (23 ft)** from the floor.

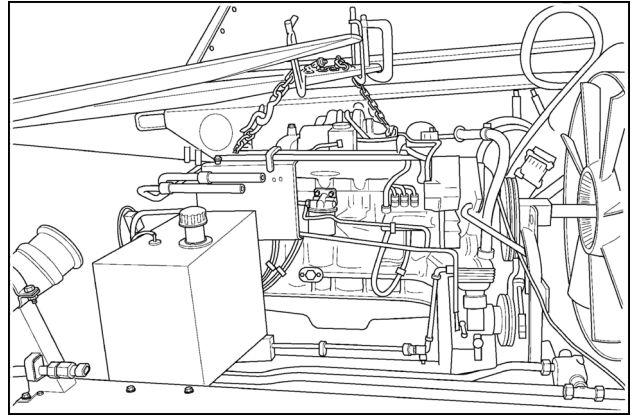

10013136 4

6. From the grain tank side of the engine, loosen the front, engine mounting bolts (1). Do not remove the mounting bolts at this time.
7. From the platform side, loosen the front, engine mounting bolts (2). Do not remove the mounting bolts at this time.

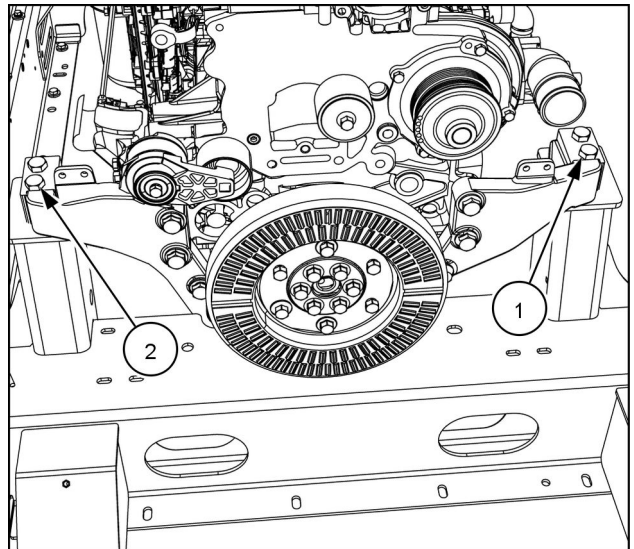

NHIL14AF01001AA 5

8. From the rear of the engine, loosen but do not remove all the bolts and washers (1) that couple the engine to the gearbox. There are twelve bolts and washers in total.
9. For safety reasons to the radiators, place a sheet of plywood, cut to size, in front of the cooler box for protection.
10. With the engine securely supported by the lifting device, remove all of the engine mounting bolts and the engine to the gearbox coupling bolts that were loosened in the previous steps.
11. Slide the engine towards the cooler box to disengage the flex plate from the gearbox input shaft.
12. Carefully lift the engine from the frame and remove from the combine.

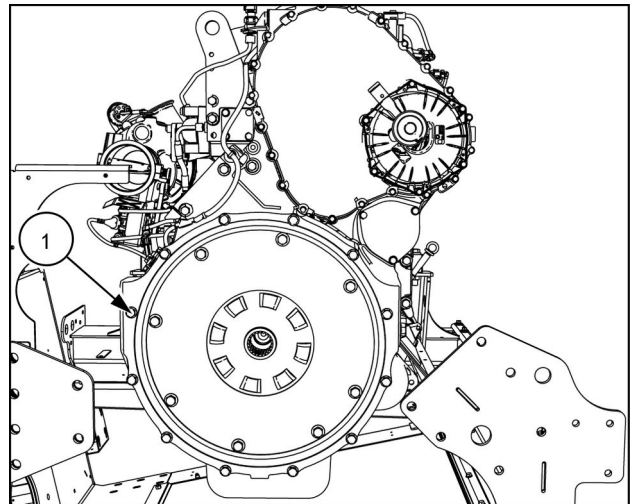

NHIL14AF01004AA 6

Next operation:
Engine - Install (10.001).

Engine - Install

| | |
|------------------|----|
| AXIAL-FLOW® 7240 | WE |
| AXIAL-FLOW® 8240 | WE |

⚠ WARNING

Avoid injury! Always do the following before lubricating, maintaining, or servicing the machine.

1. Disengage all drives.
2. Engage parking brake.
3. Lower all attachments to the ground, or raise and engage all safety locks.
4. Shut off engine.
5. Remove key from key switch.
6. Switch off battery key, if installed.
7. Wait for all machine movement to stop.

Failure to comply could result in death or serious injury.

W0047A

⚠ WARNING

Heavy objects!

Lift and handle all heavy components using lifting equipment with adequate capacity. Always support units or parts with suitable slings or hooks. Make sure the work area is clear of all bystanders.

Failure to comply could result in death or serious injury.

W0398A

Prior operation:

Engine - Remove (10.001)

NOTE: Illustrations are for reference only. It may not be the actual engine.

1. Before installing the engine, apply **LOCTITE® SILVER GRADE ANTI-SEIZE** to the input shaft (1) of the gearbox.

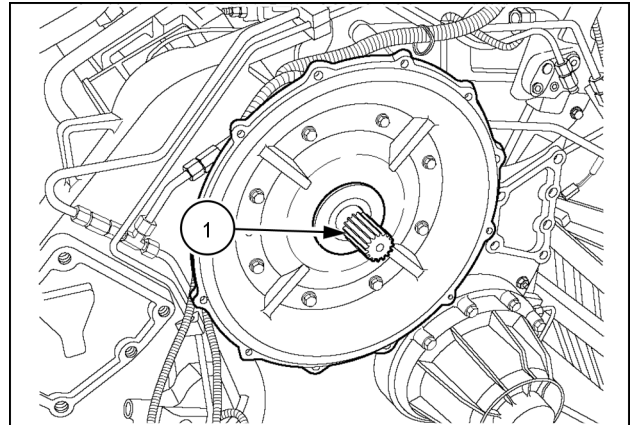

83070284 1

2. Attach a suitable chain to the front lift eye (1) at the front of the engine.

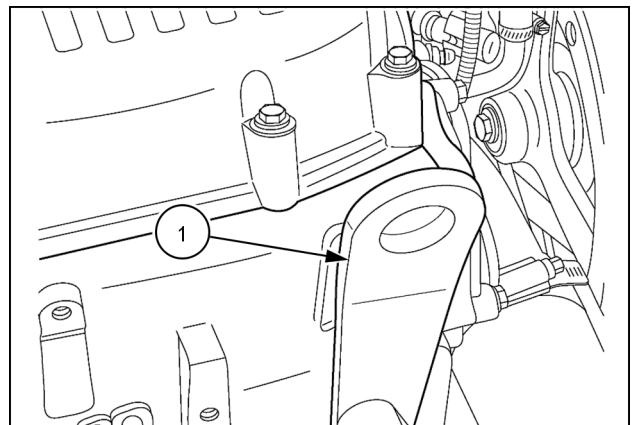

86070259 2

3. Attach a suitable chain to the back lift eye (1) at the rear of the engine.

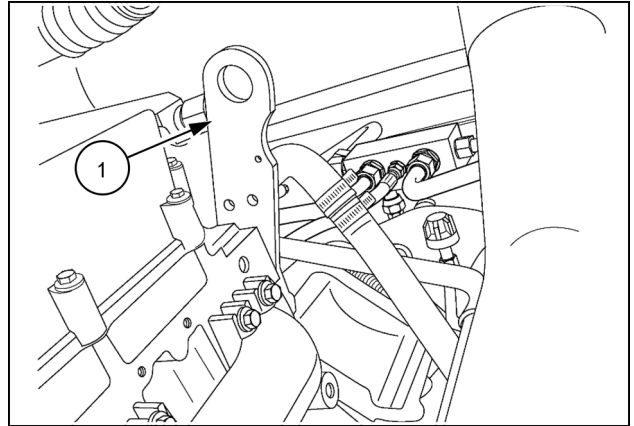

86070260 3

4. Connect the lift chain to a suitable lifting device.
5. Carefully lift the engine above the combine and lower into position in the frame.

NOTE: The lifting device should be rated for at least **907.2 kg (2000 lb)**. Allow enough clearance to lift the engine from the combine, approximately **907.2 kg (2000 lb)** from the floor.

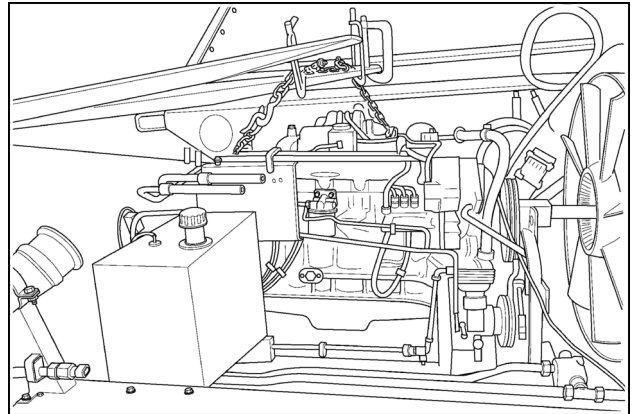

10013136 4

6. For safety reasons to the radiator, place a sheet of plywood, cut to size, in front of the radiator for protection.
7. Slide the engine towards the gearbox onto the gear box input shaft.
8. Align the holes of the gearbox with the engine and hand start a bolt with a washer (1) on each side of the coupling, going back and forth until all bolts with washers are installed.

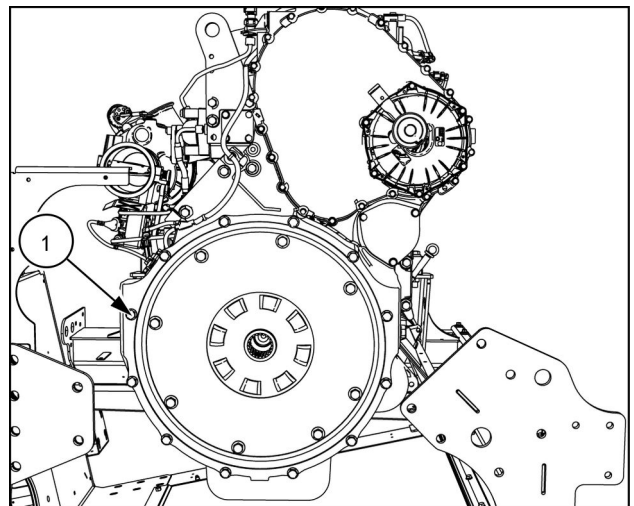

NHIL14AF01004AA 5

9. With the engine positioned in the frame, align the front mounting hole on the grain tank side and install the bolt with washers **(1)** into the mount. Do not tighten yet.
10. Align the front mounting hole on the platform side. Install the bolt with washers **(1)** into the mount.
11. Tighten and torque the front engine mounting bolts to **217 Nm (160.1 lb ft)**.
12. Tighten and torque the engine gearbox bolts to **41 - 51 Nm (30.2 - 37.6 lb ft)**.

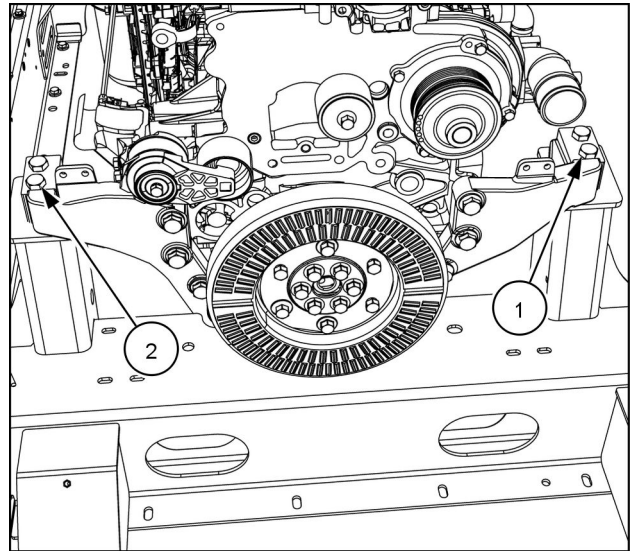

NHIL14AF01001AA 6

Next Operations

- Central wiring harness - Install (55.100)
- Diesel Oxidation Catalyst (DOC) - Install (10.500)
- Selective Catalytic Reduction (SCR) muffler and catalyst - Install (10.500)
- Selective Catalytic Reduction (SCR) exhaust treatment - Install DEF hose bundle (10.500)
- Deaeration tank - Install (10.400)
- Radiator hoses - Install (10.400)
- Engine cooling system - Filling (10.400)
- Aftercooler air supply and return lines - Install air return tube (10.310)
- Aftercooler air supply and return lines - Install air supply tube (10.310)
- Exhaust muffler - Install exhaust tube from turbo charger to Diesel Oxidation Catalyst (DOC) (10.254)
- Exhaust muffler - Install mixer tube (10.254)
- Fuel return lines - Install to the engine (10.210)
- Fuel supply lines Low pressure - Install to the engine (10.210)
- Fan and drive - Install (10.414)
- Air conditioning - Service instruction (50.200)
- Air intake system - Install (10.202)
- Engine hood and panels - Install (90.100)

13. Engage the battery connect switch (1).

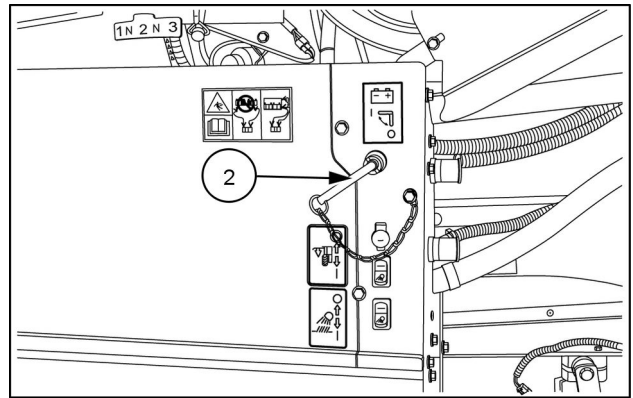

NHIL13AF00586AA 7

14. Disconnect the fuel pump wire connector (1) to disable the fuel pump (2).

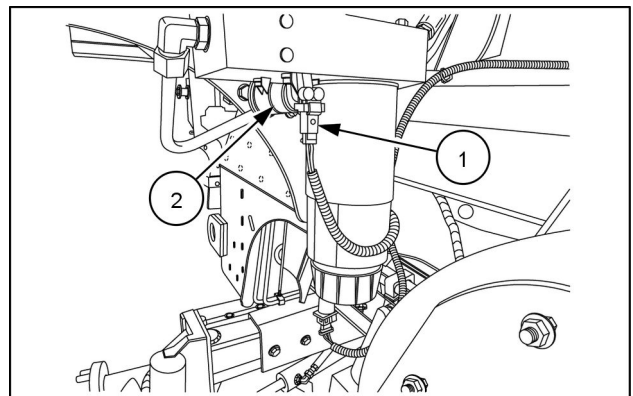

NHIL14AF00745AA 8

15. Check the engine oil level and top off if necessary.
16. Crank the engine over for three ten second intervals. This will distribute lubricating oil to the engine operating systems and will allow oil pressure to be built before starting the engine.

17. Connect the fuel pump wire connector **(1)** to the fuel pump **(2)** and bleed the air from fuel injection system, as described in the Operators manual.

18. Start the engine and check all hoses, fittings and clamps for leaks.

NOTICE: Monitor the instrument warning light bar at all times during initial engine start up to ensure the engine has proper oil pressure. Shut down the engine immediately if oil pressure is not adequate.

19. Ensure all electrical components are working properly.

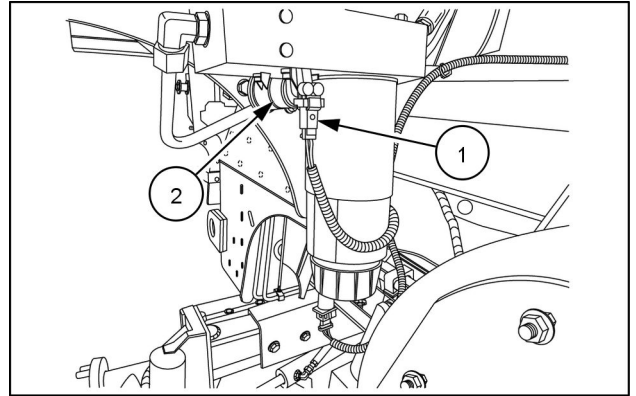

NHIL14AF00745AA 9

Engine - Remove

AXIAL-FLOW® 9240

WE

▲ WARNING

Avoid injury! Always do the following before lubricating, maintaining, or servicing the machine.

1. Disengage all drives.
 2. Engage parking brake.
 3. Lower all attachments to the ground, or raise and engage all safety locks.
 4. Shut off engine.
 5. Remove key from key switch.
 6. Switch off battery key, if installed.
 7. Wait for all machine movement to stop.
- Failure to comply could result in death or serious injury.

W0047A

▲ WARNING

Heavy objects!

Lift and handle all heavy components using lifting equipment with adequate capacity. Always support units or parts with suitable slings or hooks. Make sure the work area is clear of all bystanders. Failure to comply could result in death or serious injury.

W0398A

Prior operation:

Engine hood - Remove (90.105)

Prior operation:

Central wiring harness - Remove (55.100)

Prior operation:

Fan and drive - Remove (10.414)

Prior operation:

Air conditioning - Service instruction (50.200)

Prior operation:

Air intake system - Remove (10.202)

Prior operation:

Fuel supply lines Low pressure - Remove from the engine (10.210)

Prior operation:

Fuel return lines - Remove from the engine (10.210)

Prior operation:

Exhaust muffler - Remove mixer tube (10.254)

Prior operation:

Exhaust muffler - Remove exhaust tube from turbo charger to Diesel Oxidation Catalyst (DOC) (10.254)

Prior operation:

Aftercooler air supply and return lines - Remove air supply tube (10.310)

Prior operation:

Aftercooler air supply and return lines - Remove air return tube (10.310)

Prior operation:

Engine cooling system - Drain fluid (10.400)

Prior operation:

Radiator hoses - Remove (10.400)

Prior operation:

Deaeration tank - Remove (10.400)

Prior operation:

Selective Catalytic Reduction (SCR) exhaust treatment - Remove DEF hose bundle (10.500)

Prior operation:

Selective Catalytic Reduction (SCR) muffler and catalyst - Remove (10.500)

Prior operation:

Diesel Oxidation Catalyst (DOC) - Remove (10.500)

NOTE: Illustrations are for reference only. It may not be the actual engine.

1. Disengage the battery connect switch (1).

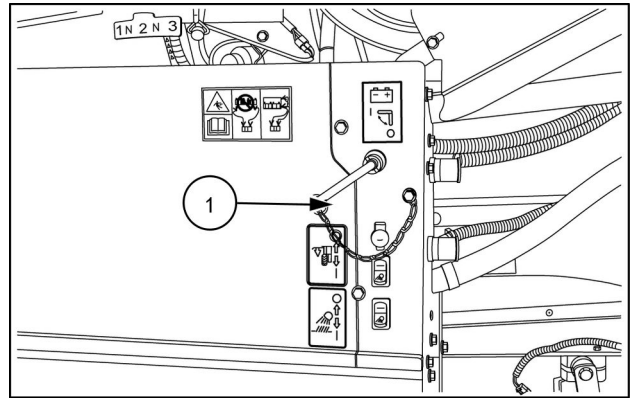

NHIL13AF00586AA 1

2. Attach a suitable chain to the front lift eye (1) at the front of the engine.

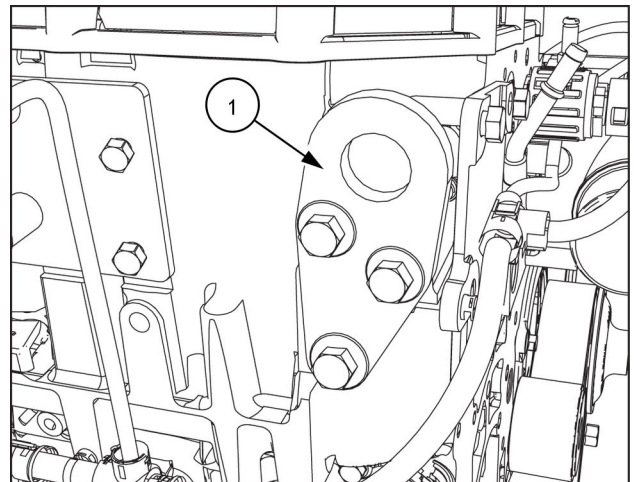

NHIL14AF00431AA 2

3. Attach a suitable chain to the back lift eye (1) at the rear of the engine.

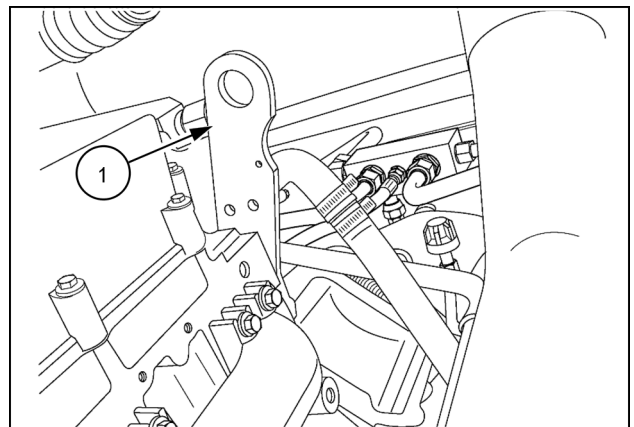

86070260 3

4. Connect the lift chain to a suitable lifting device.
5. Raise the lifting device enough to support the engine during removal of the engine mounting bolts.

NOTE: Illustration is for reference only. It may not be the actual engine.

NOTE: The lifting device should be rated for at least **907.2 kg (2000 lb)**. Allow enough clearance to lift the engine from the combine, approximately **7.0 m (23 ft)** from the floor.

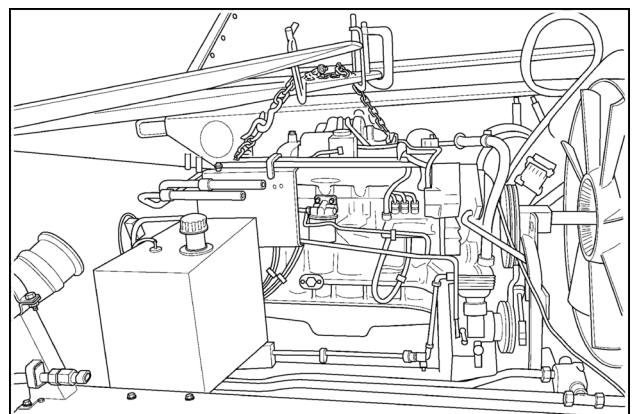

10013136 4

6. From the grain tank side of engine, loosen the front two engine mounting bolts (1). Do not remove the mounting bolts at this time.
7. From the platform side, loosen the two front, engine mounting bolts (2). Do not remove the mounting bolts at this time.

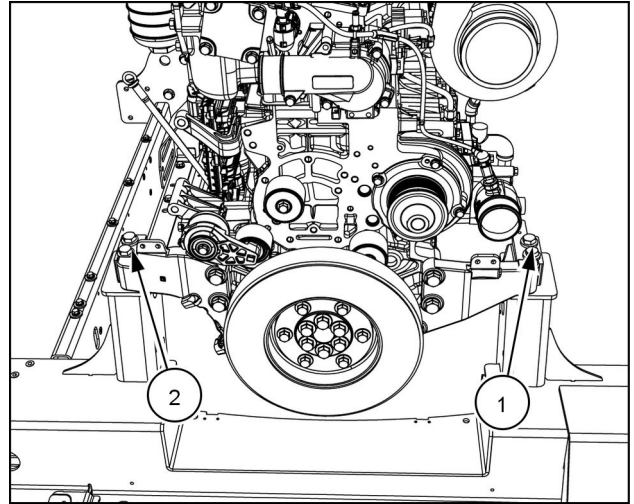

NHIL14AF01003AA 5

8. Loosen but do not remove all the bolts and washers (1) that couple the engine to the gearbox. There are twelve bolts and washers in total.
9. For safety reasons to the radiators, place a sheet of plywood, cut to size, in front of the cooler box for protection.
10. With the engine securely supported by the lifting device, remove all of the engine mounting bolts and the engine to the gearbox coupling bolts that were loosened in the previous steps.
11. Slide the engine towards the cooler box to disengage the flex plate from the gearbox input shaft.
12. Carefully lift the engine from the frame and remove from the combine.

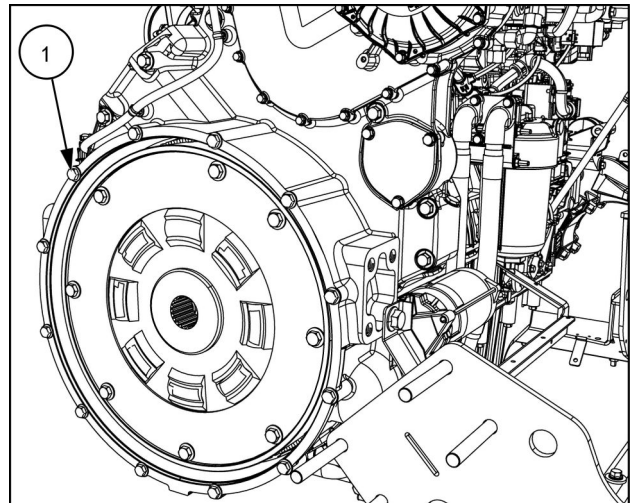

NHIL14AF01005AA 6

Next operation:
Engine - Install (10.001).

Engine - Install

AXIAL-FLOW® 9240

WE

⚠ WARNING

Avoid injury! Always do the following before lubricating, maintaining, or servicing the machine.

1. Disengage all drives.
 2. Engage parking brake.
 3. Lower all attachments to the ground, or raise and engage all safety locks.
 4. Shut off engine.
 5. Remove key from key switch.
 6. Switch off battery key, if installed.
 7. Wait for all machine movement to stop.
- Failure to comply could result in death or serious injury.

W0047A

⚠ WARNING

Heavy objects!

Lift and handle all heavy components using lifting equipment with adequate capacity. Always support units or parts with suitable slings or hooks. Make sure the work area is clear of all bystanders.

Failure to comply could result in death or serious injury.

W0398A

Prior operation:

Engine - Remove (10.001)

NOTE: Illustrations are for reference only. It may not be the actual engine.

1. Before installing the engine, apply **LOCTITE® SILVER GRADE ANTI-SEIZE** to the input shaft (1) of the gearbox.

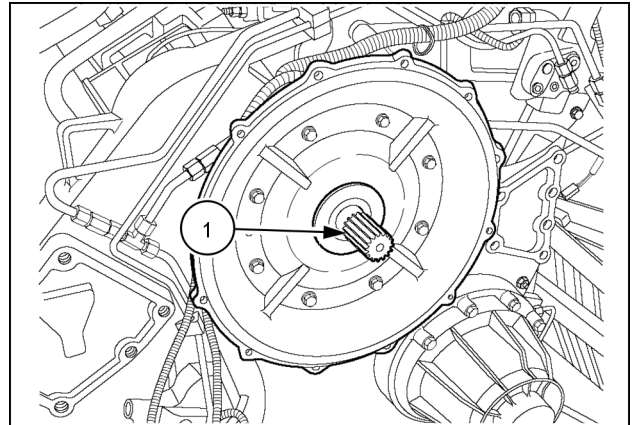

83070284 1

2. Attach a suitable chain to the front lift eye (1) at the front of the engine.

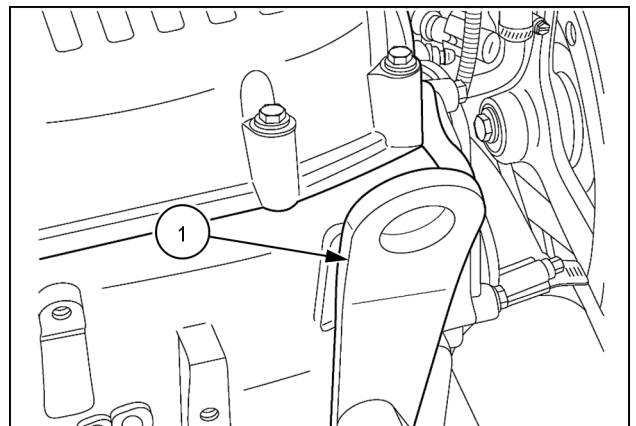

86070259 2



Suggest:

If the above button click is invalid.

Please download this document

first, and then click the above link

to download the complete manual.

Thank you so much for reading

3. Attach a suitable chain to the back lift eye (1) at the rear of the engine.

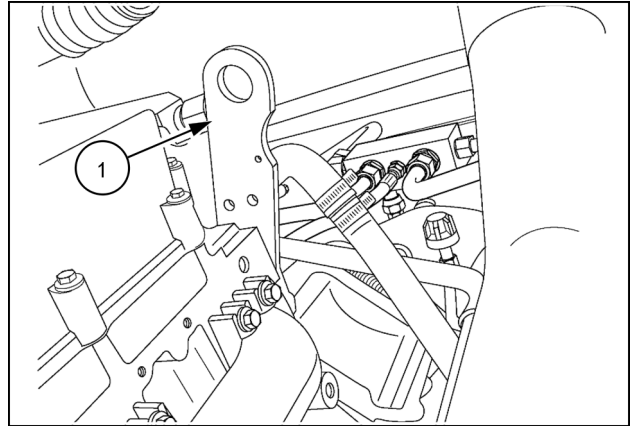

86070260 3

4. Connect the lift chain to a suitable lifting device.
5. Carefully lift the engine above the combine and lower into position in the frame.

NOTE: The lifting device should be rated for at least **907.2 kg (2000 lb)**. Allow enough clearance to lift the engine from the combine, approximately **907.2 kg (2000 lb)** from the floor.

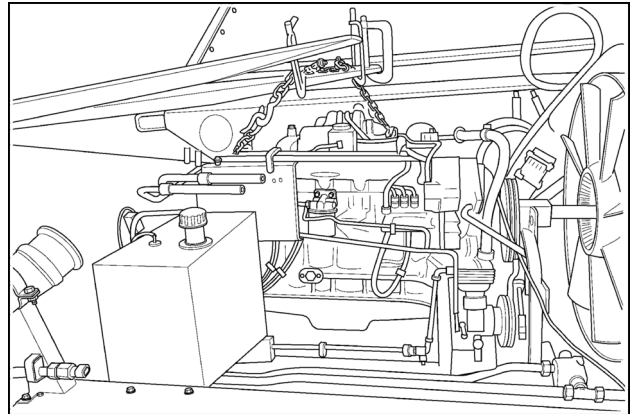

10013136 4

6. For safety reasons to the radiator, place a sheet of plywood, cut to size, in front of the radiator for protection.
7. Slide the engine towards the gearbox onto the gear box input shaft.
8. Align the holes of the gearbox with the engine and hand start a bolt with a washer (1) on each side of the coupling, going back and forth until all bolts with a washer are installed.

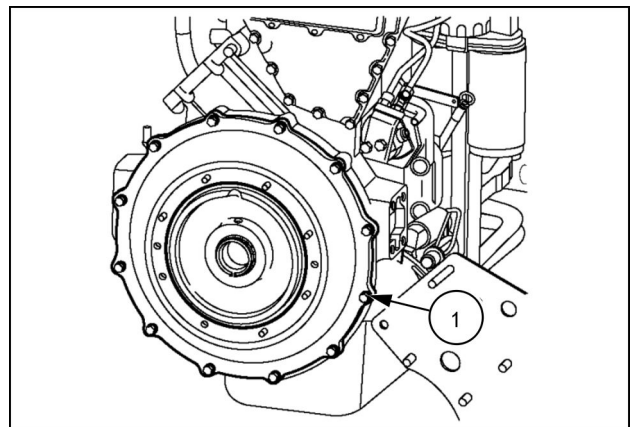

83090610 5

<https://www.ebooklibonline.com>

Hello dear friend!

Thank you very much for reading.

Enter the link into your browser.

The full manual is available for immediate download.

<https://www.ebooklibonline.com>