

9350 Tractor Service Manual

Table of Contents

General	Section	Form No.
Loctite Product Chart		8-98901
General Information and Specifications	1002	7-65410
Engine		
Engine Removal	2001	8-83810
Fuel System		
Fuel System & Filters	3001	8-83610
Electrical		
Wiring Schematic and Troubleshooting	4001	8-83230
Starting Motor - Delco Remy Series 42 MT	4002	8-83490
Battery Servicing & Testing	4003	8-83530
Delco 21-SI Alternator Testing & Repair	4014	8-83450
Steering		
Tilt/Telescoping Steering Column	5001	8-83470
"Wide Angle" Steering Control Unit	5002	8-83790
Double Selector Steering Valve	5004	8-83780
Steering Makeup Valve	5005	8-83770
Front Axle Steering Electronic Alignment/Calibration	5008	8-83160
Front Axle Steering Electronic Alignment/Calibration (P.I.N. JEE0036001 and after)	5009	8-83290
Power Train		
EW-16 Powershift Transmission Removal	6001	8-83800
PTO Driveline Hanger Bearing	6002	8-83700
692-42/52 and 692-40/50 Series Bar Axle Repair	6003	8-83130
EW-16 PowerShift Transmission Service	6004	8-83410
PTO Drive Unit Repair	6005	8-83420
Rear Driveline Support Bearing	6006	8-83710
Front Steerable Axle Repair	6007	8-83840
PTO Drop Box Repair	6008	8-83440
Differential Lock Electric Shift Motor Testing and Repair	6009	8-82651
694-60/70 and 694-62/72 Raba Axle Repair	6010	8-83120
Charge Pump Repair EW-16 PowerShift, HM-2 and HM-24 SynchroShift Transmission	6014	8-83460
Transmission Drive Coupler Removal & Installation	6016	8-83400

CASE CORPORATION
700 State Street
Racine, WI 53404 U.S.A

CASE CORPORATION
3350 South Service Road
Burlington, ON L7N 3M6 CANADA

Reprinted

© 1998 Case Corporation
Printed in U.S.A.

Rac 8-83372

December, 1995 (Revised November, 1998)

Power Train (Cont'd)

HM-2 and HM-24 SynchroShift Transmission Removal	6020	8-83300
HM-2 and HM-24 SynchroShift Transmission Pressure Testing	6021	8-83270
12 Speed SynchroShift and 24 Speed HI-LO SynchroShift Transmission Repair	6023	8-83020

Brakes

Dual Stage Master Cylinder	7001	8-83310
Caliper Disc Brake System	7002	8-83330
Single Stage Master Cylinder	7003	8-83320

Hydraulic System

Hydraulic Troubleshooting and Schematics	8000	8-83200
Remote Hydraulic Control Valve	8001	8-83670
Hydraulic Piston Pump	8002	8-83650
Hydraulic Gear Pump	8003	8-83660
Three Point Hitch Valve	8005	8-84050
Hydraulic Filters	8006	8-83630
Electronic Hitch Calibration	8009	8-83170
Three Point Hitch Valve PIN JEE0069665 and After	8013	7-85380

Chassis

Cab Removal	9001	8-83860
Center Hinge Bearings and Connecting Link	9002	8-83580
Drawbar Removal	9003	8-83510
Radiator Removal	9004	8-83820
Hood and Grille	9005	8-83830
HVAC System	9006	8-83550
Air Conditioner System - Refrigerant Recovery, System Evacuation and Recharging	9007	8-83560
Air Conditioner Compressor	9008	8-83640
Mechanical Seat	9009	8-83480
Deluxe Air Seat	9010	8-83940
Weighting the 4WD Tractor	9017	8-83040

Section 1002

1002

GENERAL INFORMATION AND SPECIFICATIONS For 9350 Series Tractor

<https://www.ebooklibonline.com>

Hello dear friend!

Thank you very much for reading.

Enter the link into your browser.

The full manual is available for immediate download.

<https://www.ebooklibonline.com>



TABLE OF CONTENTS

GENERAL TORQUE SPECIFICATION TABLE	
SAE	3
Metric	3
Hydraulic Tubes and Fittings	4
FLUID CAPACITIES AND TYPES	5
SPECIFICATIONS	6 - 8
WHEEL BOLT TORQUES	8
TRAVEL SPEEDS	9
OVERALL MEASUREMENTS	10
ELECTRICAL SYSTEM	11
AUXILIARY POWER CONNECTIONS	12 - 14
TRANSMISSION CONTROLLER AND CLUSTER CALIBRATION	15
PowerShift Transmission Procedure	15
SynchroShift Transmission Procedure	16
Dynamic Rolling Radius	17
TIRE CODE NUMBERS	18
STEERING SYSTEM CALIBRATION	19 - 23
TIRE INFLATION SPECIFICATIONS	24, 25
TIRE PRESSURE AND LOAD CHARTS	26 - 29
BAR AXLE WHEEL ADJUSTMENT	29, 30
TREAD SETTINGS	31 - 45
TRACTOR BALLAST	46 - 50
CHEMICAL TANK MOUNTING	51, 52

NOTE: Case Corporation reserves the right to make improvements in design or changes in specifications at any time without incurring any obligation to install them on units previously sold.

SAE FASTENER TORQUE CHART

NOTE: Use these torques, unless special torques are specified. Values are for UNC and UNF thread fasteners, plated or unplated, as received from supplier. Fasteners can be dry or lubricated with normal engine oil. Values do not apply if graphite, moly-disulphide or other extreme pressure lubricant is used.

SAE Grade No	2				5				8*			
Bolt head identification (See Note 1)												
Bolt Size	LB FT		Nm		LB FT		Nm		LB FT		Nm	
	Min	Max	Min	Max	Min	Max	Min	Max	Min	Max	Min	Max
1/4	5	6	7	8	9	11	12	15	12	15	16	20
5/16	10	12	14	16	17	20.5	23	28	24	29	33	39
3/8	20	23	27	31	35	42	48	57	45	54	61	73
7/16	30	35	41	47	54	64	73	87	70	84	95	114
1/2	45	52	61	70	80	96	109	130	110	132	149	179
9/16	65	75	88	102	110	132	149	179	160	192	217	260
5/8	95	105	129	142	150	180	203	244	220	264	298	358
3/4	150	185	203	251	270	324	366	439	380	456	515	618
7/8	160	200	217	271	400	480	542	651	600	720	814	976
1	250	300	339	406	580	696	787	944	900	1080	1220	1464
1-1/8					800	880	1085	1193	1280	1440	1736	1953
1-1/4					1120	1240	1519	1681	1820	2000	2468	2712
1-3/8					1460	1680	1980	2278	2380	2720	3227	3688
1-1/2					1940	2200	2631	2983	3160	3560	4285	4827

NOTE 1 Bolt head identification marks as per grade. Manufacturing marks will vary. *Thick nuts must be used with Grade 8 bolts.

STANDARD TORQUE DATA FOR HYDRAULIC TUBES AND FITTINGS

TUBE NUTS FOR 37° FLARED FITTINGS								O-RING BOSS PLUGS, ADJUSTABLE FITTING LOCK NUTS, SWIVEL JIC - 37° SEATS			
SIZE	TUBING O.D.		THREAD SIZE	LB FT		Nm		LB FT		Nm	
	Inches	mm		Min.	Max.	Min.	Max.	Min.	Max.	Min.	Max.
4	1/4	6.4	7/16-20	9	12	12	16	6	10	8	14
5	5/16	7.9	1/2-20	12	15	16	20	10	15	14	20
6	3/8	9.5	9/16-18	21	24	29	33	15	20	20	27
8	1/2	12.7	3/4-18	35	40	47	54	25	30	34	41
10	5/8	15.9	7/8-14	53	58	72	79	35	40	47	54
12	3/4	19.1	1-1/16-12	77	82	104	111	60	70	81	95
14	7/8	22.2	1-3/16-12	90	100	122	136	70	80	95	109
16	1	25.4	1-5/16-12	110	120	149	163	80	90	108	122
20	1-1/4	31.8	1-5/8-12	140	150	190	204	95	115	129	156
24	1-1/2	38.1	1-7/8-12	160	175	217	237	120	140	163	190
32	2	50.8	2-1/2-12	225	240	305	325	250	300	339	407

Above torque figures are recommended for plain, cadmium or zinc plated fittings, dry or wet installations and swivel nuts either swaged or brazed. These torques are not recommended for tubes 1/2 inch (12.7 mm) O.D. and larger with wall thickness of 0.035 inch (0.889 mm) or less. The torque is specified for 0.035 inch (0.889 mm) wall tubes on each application individually.

STANDARD TORQUE DATA FOR HYDRAULIC TUBES AND FITTINGS

TUBE NUTS FOR 37° FLARED FITTINGS								O-RING BOSS PLUGS, ADJUSTABLE FITTING LOCK NUTS, SWIVEL JIC - 37° SEATS			
SIZE	TUBING O.D.		THREAD SIZE	TORQUE				TORQUE			
				FOOT POUNDS		NEWTON METERS		FOOT POUNDS		NEWTON METERS	
	Inches	mm		Min.	Max.	Min.	Max.	Min.	Max.	Min.	Max.
4	1/4	6.4	7/16-20	9	12	12	16	6	10	8	14
5	5/16	7.9	1/2-20	12	15	16	20	10	15	14	20
6	3/8	9.5	9/16-18	21	24	29	33	15	20	20	27
8	1/2	12.7	3/4-18	35	40	47	54	25	30	34	41
10	5/8	15.9	7/8-14	53	58	72	79	35	40	47	54
12	3/4	19.1	1-1/16-12	77	82	104	111	60	70	81	95
14	7/8	22.2	1-3/16-12	90	100	122	136	70	80	95	109
16	1	25.4	1-5/16-12	110	120	149	163	80	90	108	122
20	1-1/4	31.8	1-5/8-12	140	150	190	204	95	115	129	156
24	1-1/2	38.1	1-7/8-12	160	175	217	237	120	140	163	190
32	2	50.8	2-1/2-12	225	240	305	325	250	300	339	407

Above torque figures are recommended for plain, cadmium or zinc plated fittings, dry or wet installations.

Swivel nuts either swaged or brazed.

These torques are not recommended for tubes 1/2 inch (12.7 mm) O.D. and larger with wall thickness of 0.035 inch (0.889 mm) or less. Torque is specified for 0.035 inch (0.889 mm) wall tubes on each application individually.

2001

Section 2001

ENGINE REMOVAL 9350 Model Tractors

CASE CORPORATION
700 State Street
Racine, WI 53404 U.S.A.

CASE CANADA CORPORATION
3350 SOUTH SERVICE ROAD
BURLINGTON, ON L7N 3M6 CANADA

Rac 8-83810

© 1996 Case Corporation
Printed in U.S.A.
July, 1996

ENGINE REMOVAL

STEP 1

See Section 6005 in this manual for instructions to remove the hood and grille.

STEP 2

See Section 9007 in this manual for instructions on discharging the air conditioning system.

STEP 3

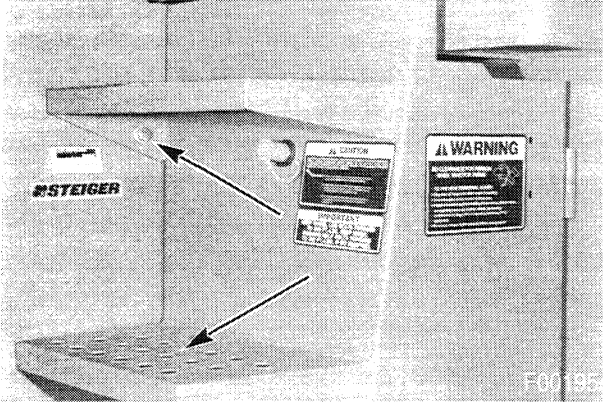

Remove the two bolts from the battery access door.

STEP 4

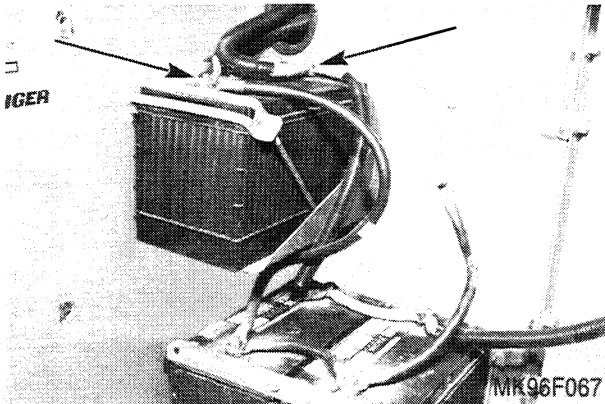

Open the battery access door and disconnect the negative and positive battery cables from the upper battery.

NOTE: Always disconnect the negative battery cable first.

STEP 5

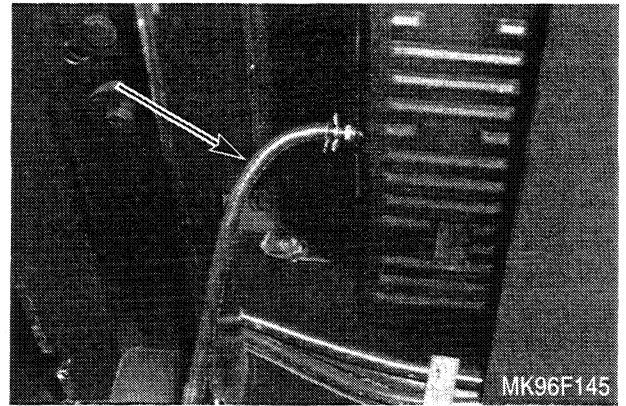

Install a short length of hose on the radiator drain valve. Open the valve and drain the radiator.

STEP 6

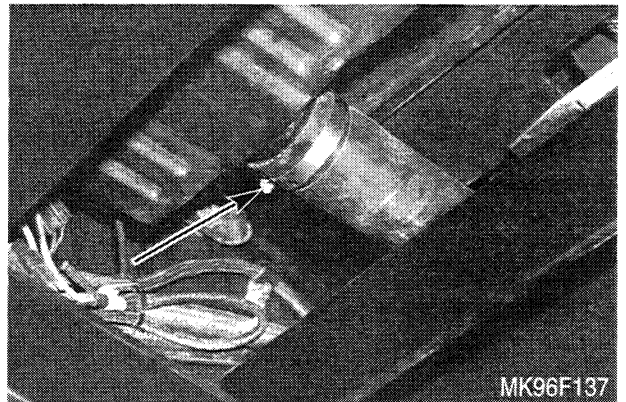

Place a catch pan under the lower radiator hose. Loosen the hose clamp and remove the hose.

STEP 7

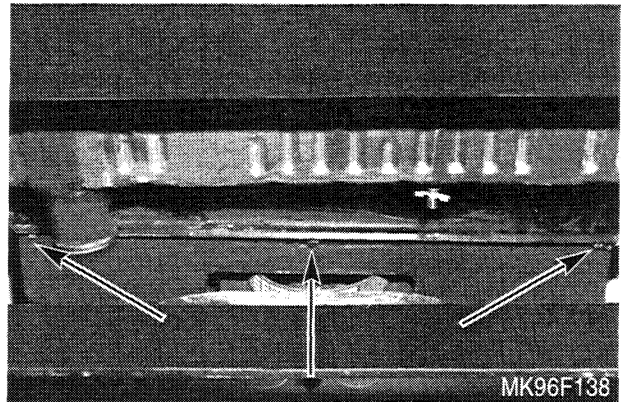

Remove the bottom fan shield.

STEP 8

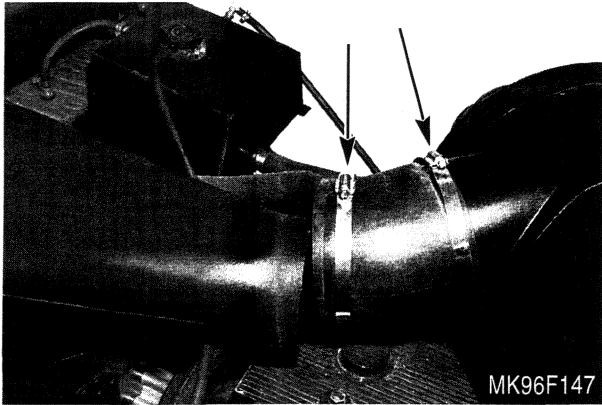

Loosen both hose clamps and slide the air duct elbow (Item 1) off the air duct tube (Item 2) and onto the air filter cannister (Item 3).

STEP 9

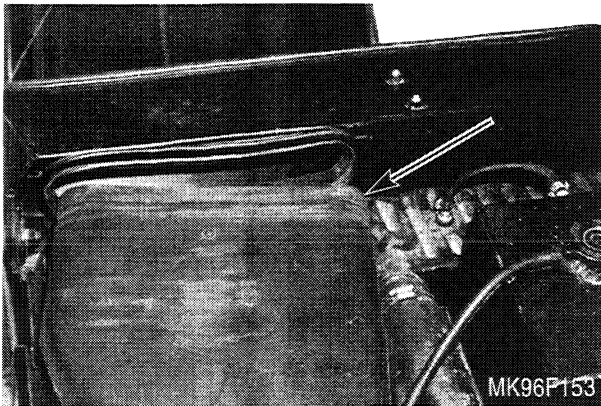

Remove the air duct tube from the radiator mount frame.

STEP 10

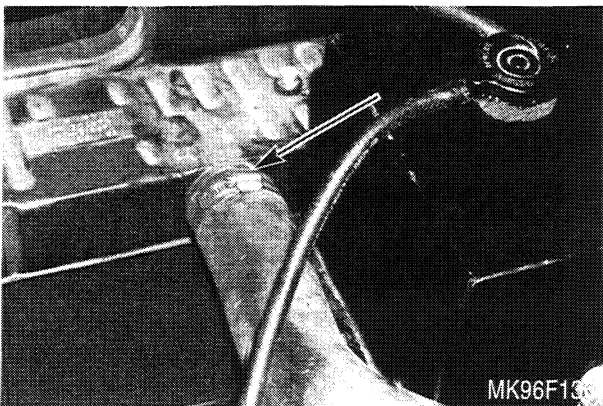

Loosen the hose clamp and remove the upper radiator hose.

STEP 11

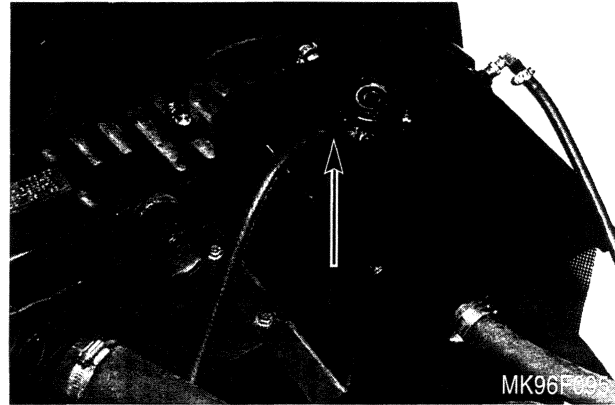

Remove the coolant recovery reservoir hose from the radiator fill tube.

STEP 12

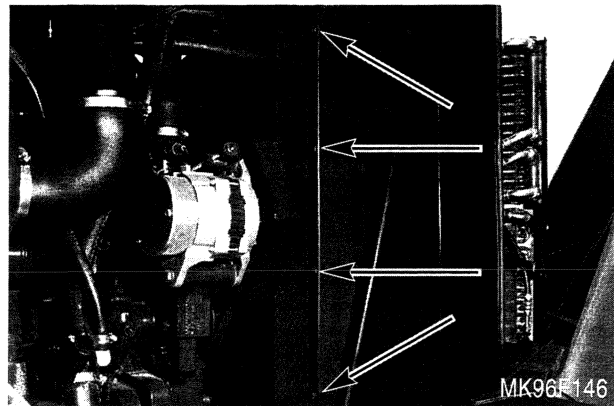

Remove the LH and RH side fan shields.

STEP 13

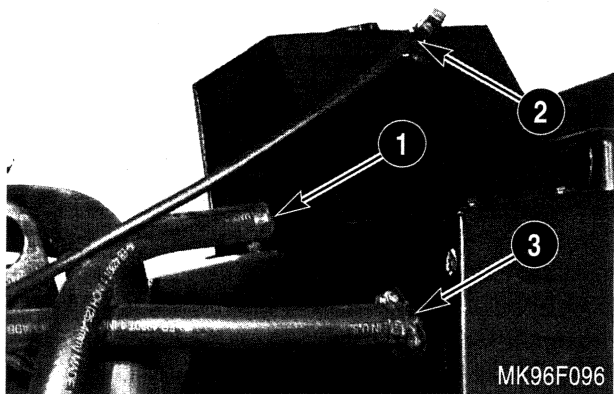

Remove the heater return hose (Item 1) and engine air bleeder hose (Item 2) from the radiator fill tank and the evacuator hose (Item 3) from the fan shroud.

STEP 14

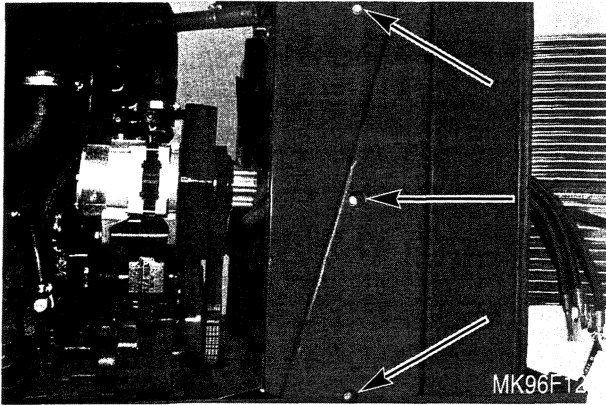

Remove the LH and RH fan shroud bolts. Move the fan shroud rearward against the crankshaft pulley.

STEP 16

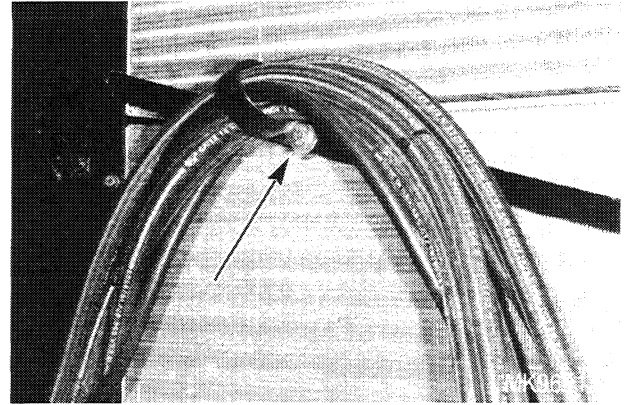

Remove the clamp supporting the hydraulic and condenser hoses.

STEP 15

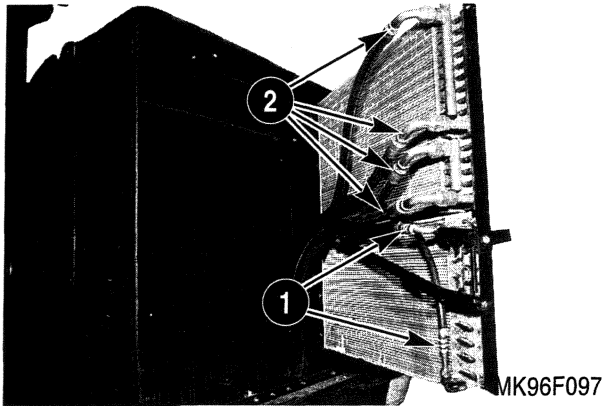

Open the cooler assembly and remove the air conditioner condenser hoses (Item 1). Cap the condenser and plug the hoses.

IMPORTANT: *The hoses and condenser must be plugged and capped immediately to prevent contamination from entering the system.*

Label the transmission and hydraulic cooler hoses (Item 2) with shipping tags. Remove the hoses. Cap the cooler fittings and plug the hoses.

STEP 17

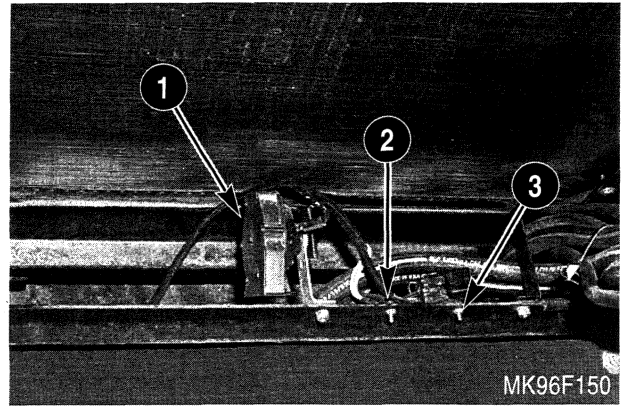

Remove the horn (Item 1), the ground bolt (Item 2) and the horn relay (Item 3) from the radiator mounting frame.

STEP 18

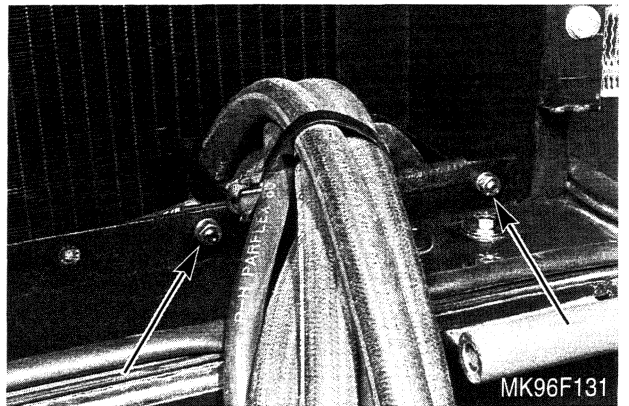

Remove the hydraulic and condenser hose frame bracket.

STEP 19

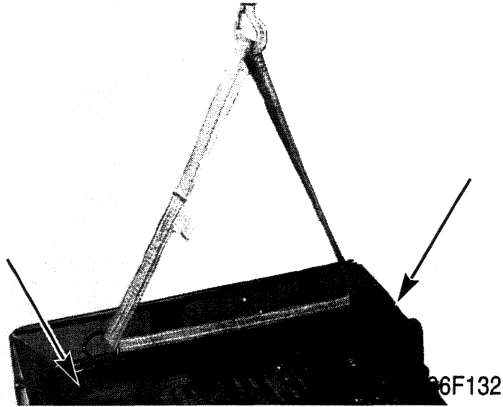

Install lifting hooks in the radiator support frame. Support the radiator assembly with an overhead hoist.

STEP 21

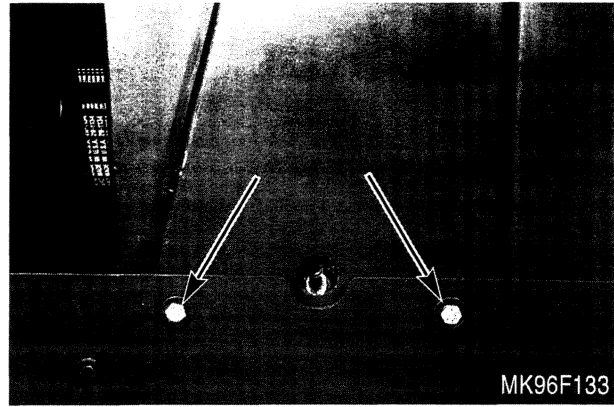

Remove the four radiator support assembly mounting bolts and washers.

STEP 20

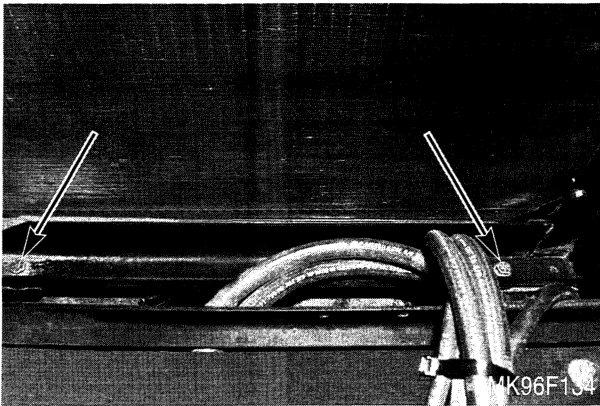

Remove the two radiator frame crossmember mounting bolts, washers and nuts.

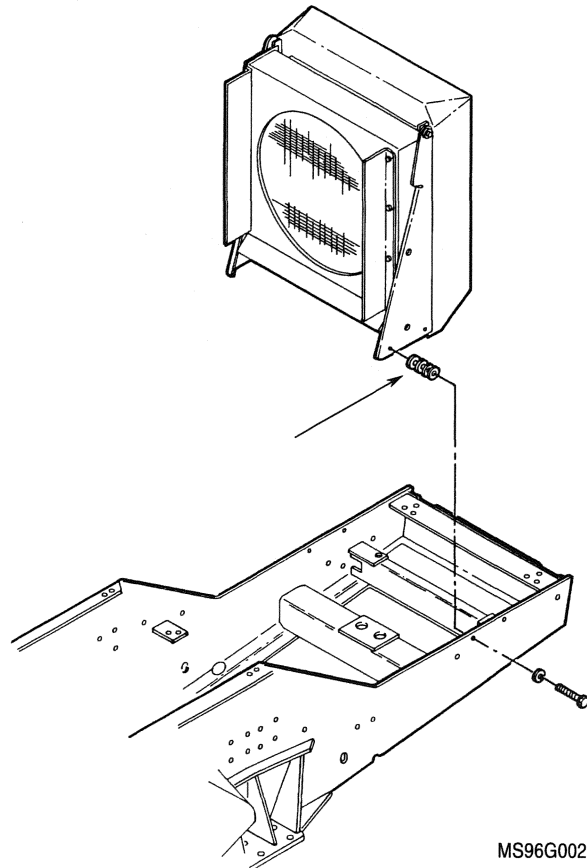

NOTE: If spacer washers are used record the number of washers between the radiator mount frame and tractor frame.

STEP 22

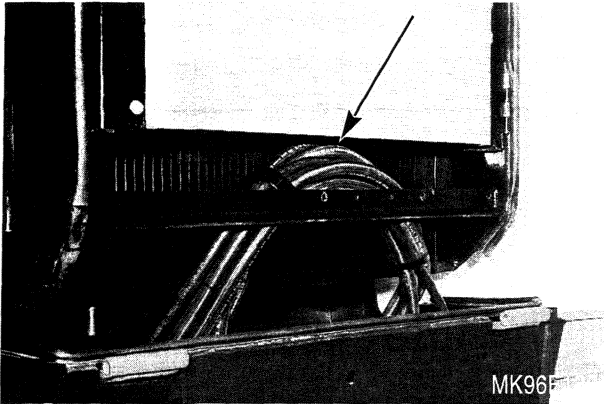

Lift the radiator and support assembly out of the tractor while guiding the condenser and hydraulic hoses through the bottom of the assembly.

STEP 23

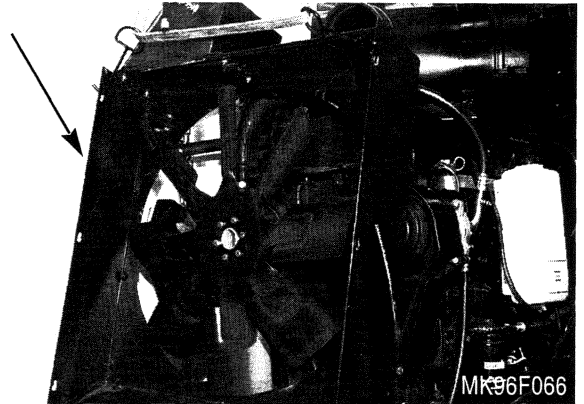

Remove the fan shroud.

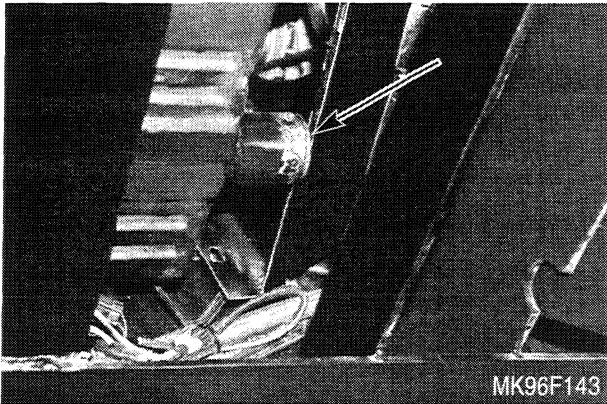

NOTE: *The clearance between the fan shroud and the lower radiator hose mounting tube is very tight. Guide the tube past the fan shroud as the radiator assembly is lifted out of the tractor.*

LEFT SIDE

STEP 24

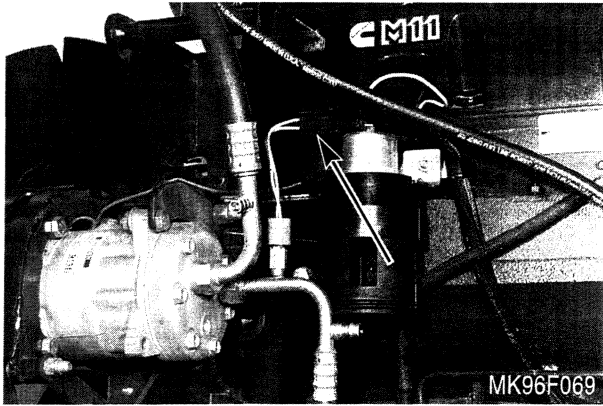

Disconnect the compressor high pressure switch wire connector from the engine wire harness.

STEP 25

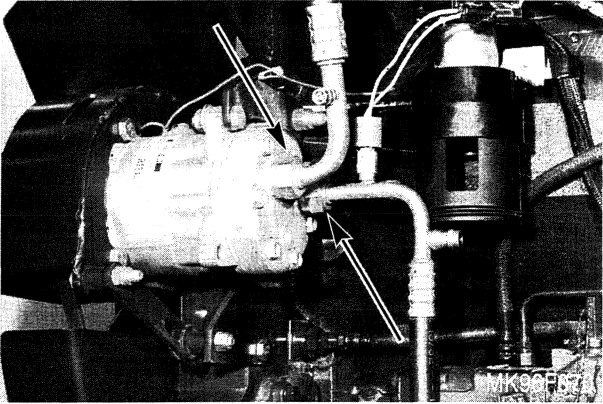

Remove the high pressure and low pressure hoses from the compressor.

IMPORTANT: Cap the fittings and plug the hoses immediately to prevent contamination from entering the hoses or compressor.

STEP 26

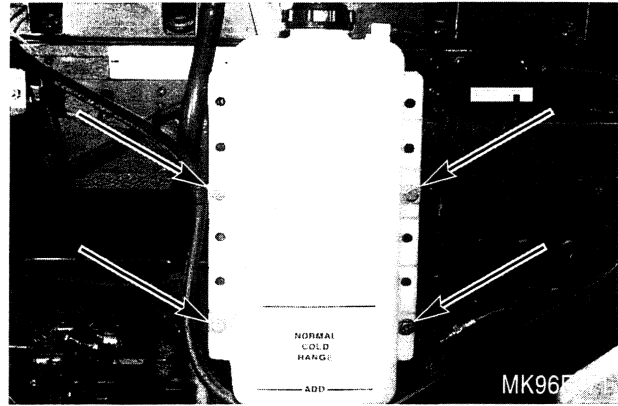

Remove the four mounting bolts and remove the coolant recovery reservoir. Cut any tie straps holding the reservoir hose to other hoses.

STEP 27

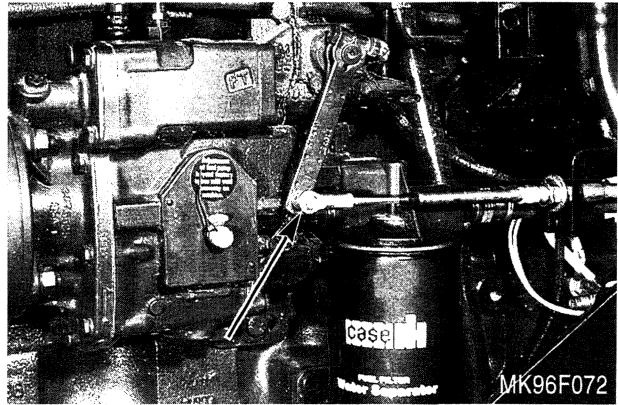

Remove the throttle linkage from the fuel pump.

STEP 28

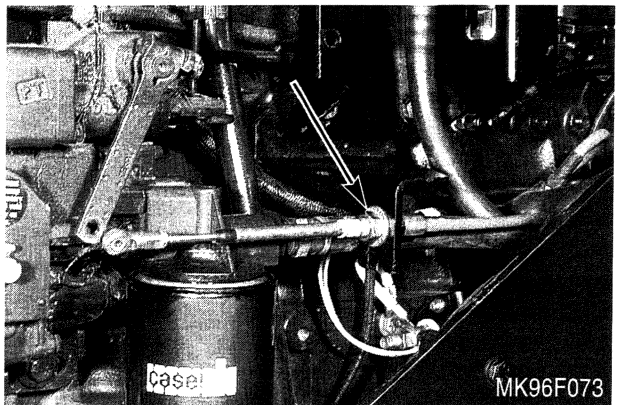

Loosen the jam nut and remove the throttle cable from the mounting bracket.

STEP 29

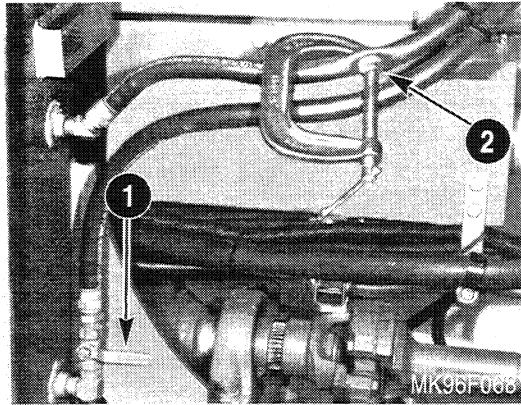

Shut off the fuel supply hose valve (Item 1) and clamp off the fuel return hose (Item 2).

NOTE: Do not tighten the clamp more than necessary or the fuel line may be damaged.

STEP 30

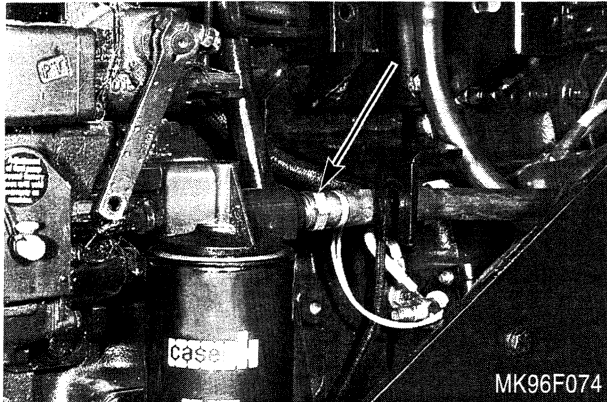

Remove the fuel supply hose from the fuel filter assembly. Install a cap on the fitting and a plug in the hose end.

NOTE: Some fuel trapped in the hose will leak out when the hose is disconnected.

STEP 31

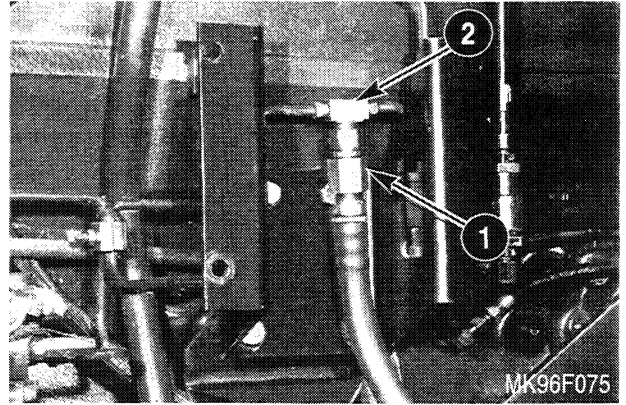

Remove the fuel return hose (Item 1) from the return lines. Cap the fitting and plug the hose end.

IMPORTANT: Use two wrenches to prevent damage to the fuel junction block (Item 2) and lines.

STEP 32

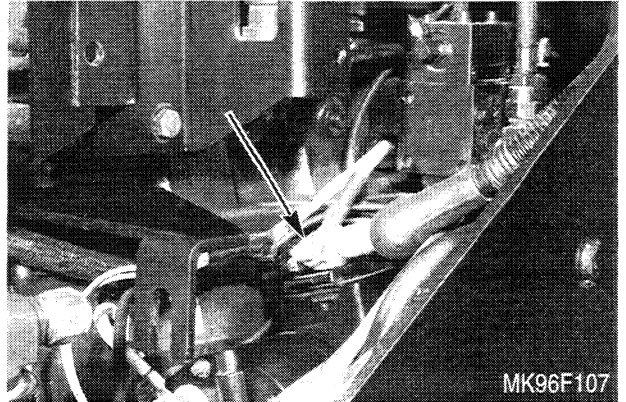

Remove the battery cable from the starter solenoid.

STEP 33

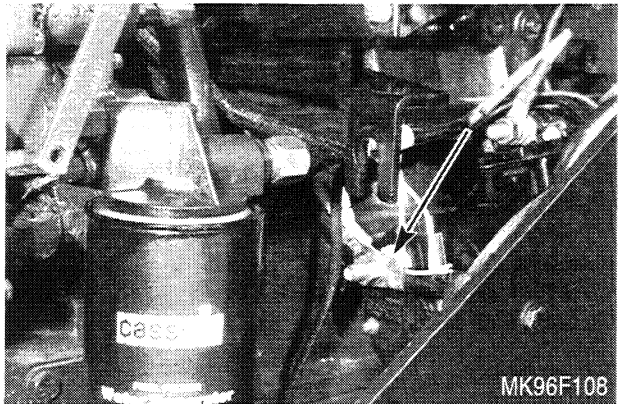

Remove the ground cable from the starter.

STEP 34

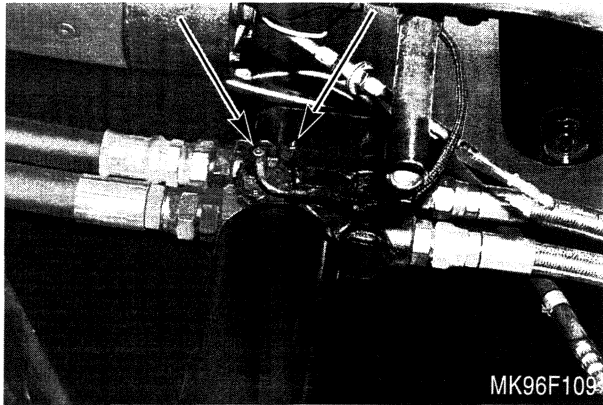

Remove the temperature switch and restriction indicator wires from the transmission filter assembly.

STEP 37

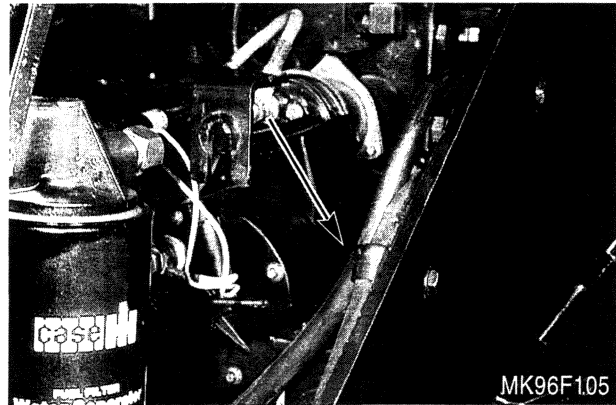

Remove the A/C high pressure hose frame clamp.

STEP 35

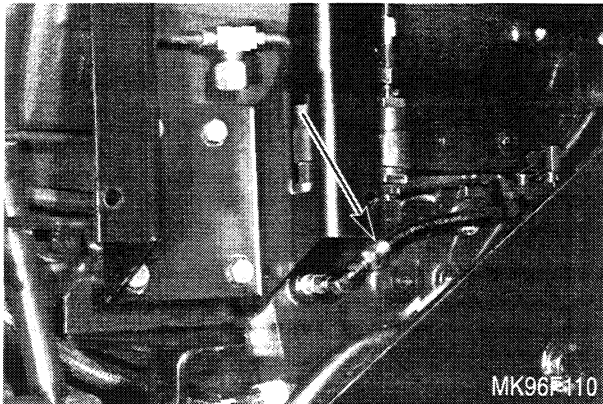

Remove the oil pressure gauge hose from the engine. Install a cap on the fitting and a plug in the hose end.

STEP 38

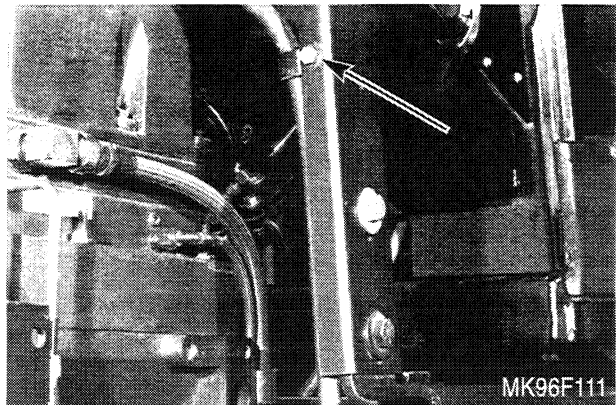

Remove the A/C high pressure hose from the hood support bracket.

STEP 36

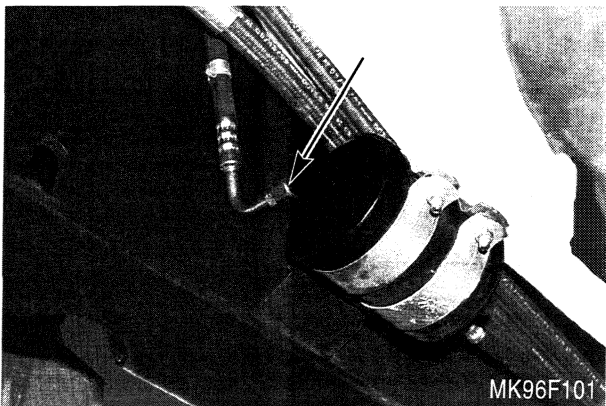

Remove the A/C high pressure hose from the dryer.

STEP 39

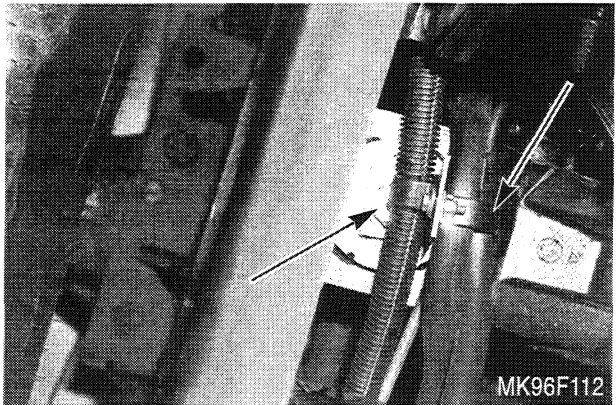

Remove the hose clamps from the LH rear engine mount.

STEP 40

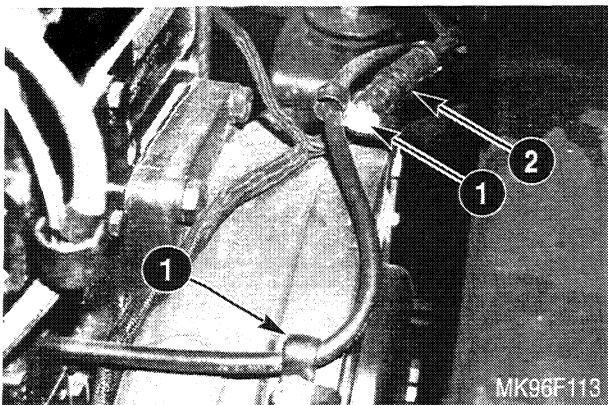

Remove the oil pressure hose clamps (Item 1) from the rear of the engine and disconnect the engine wire harness (Item 2).

STEP 42

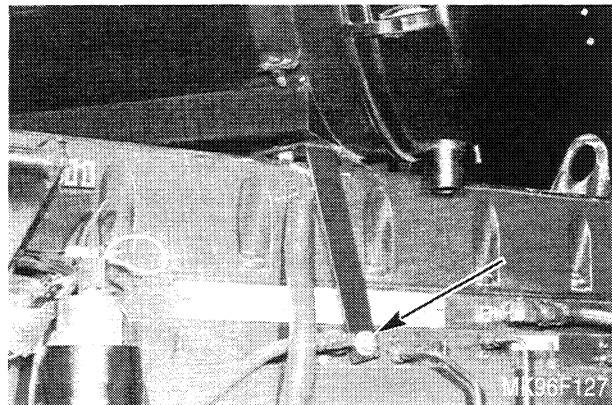

Remove the air cleaner bracket mounting bolt.

STEP 41

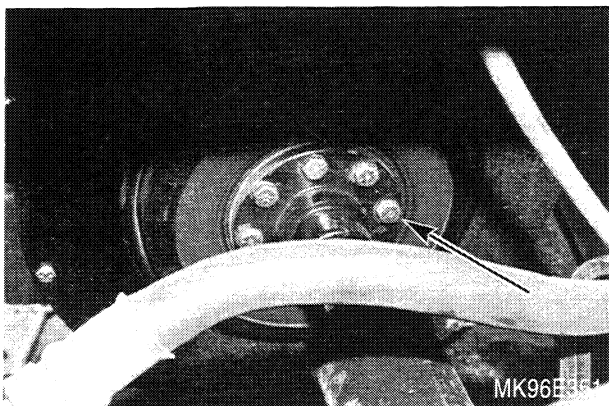

Remove the drive shaft bolts from the drive coupler and slide the drive shaft rearward away from the engine.

RIGHT SIDE

STEP 43

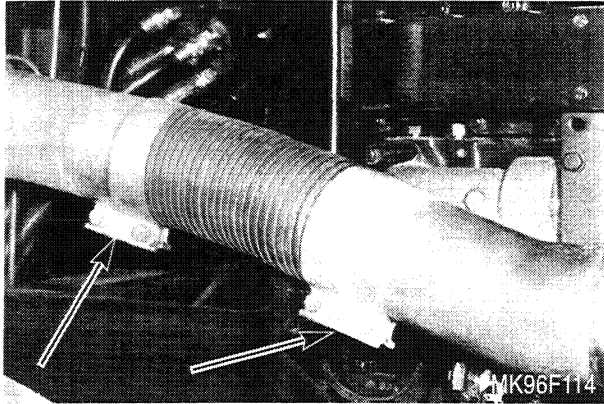

Loosen the sleeve clamps on the exhaust flex tube. Slide the flex tube off the exhaust pipe elbow.

STEP 44

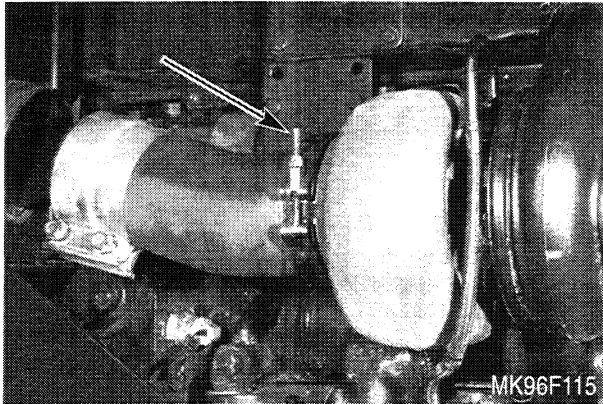

Loosen the exhaust pipe elbow clamp and remove the elbow.

STEP 45

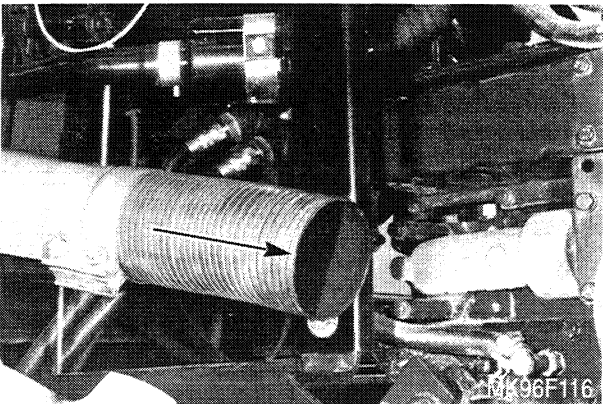

Slide the flex tube forward off the exhaust pipe and remove.

STEP 46

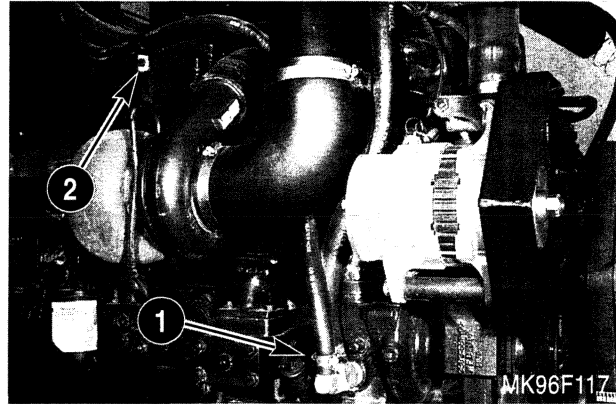

Remove the heater return hose (Item 1) and hose clamp (Item 2) from the engine and set the hose to the outside of the frame.

STEP 47

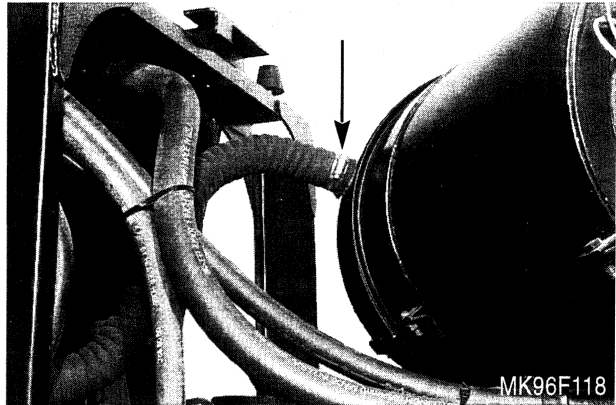

Remove the aspirator hose from the air cleaner.

STEP 48

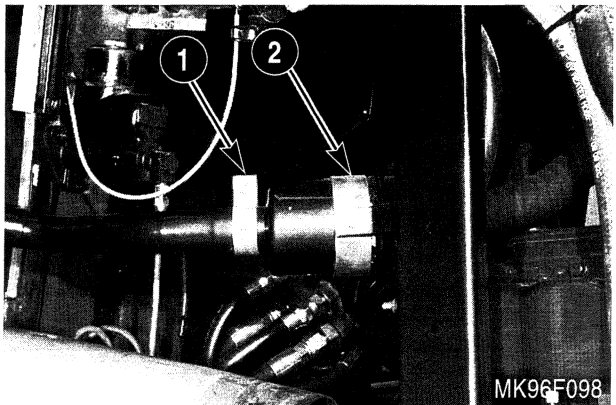

Loosen the aspirator tube clamp (Item 1) and the aspirator check valve clamp (Item 2). Remove the aspirator check valve.

STEP 49

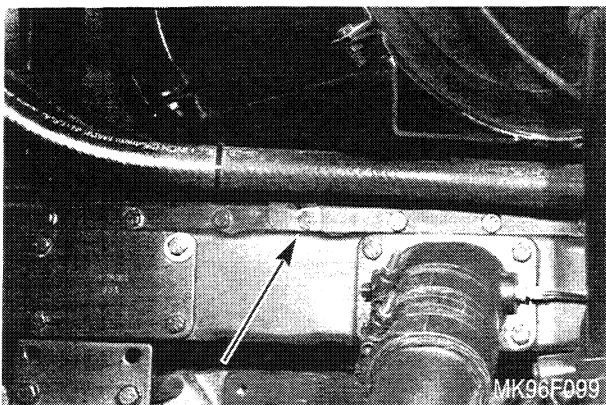

Remove the compressor low pressure hose clamp from the engine and set the hoses to the outside of the frame.

STEP 50

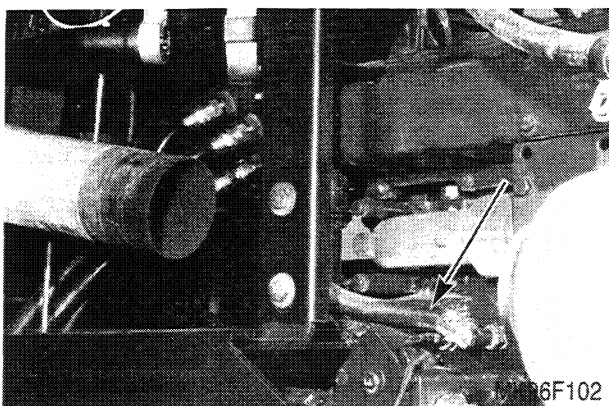

Remove the heater hose from the shut off valve.

STEP 51

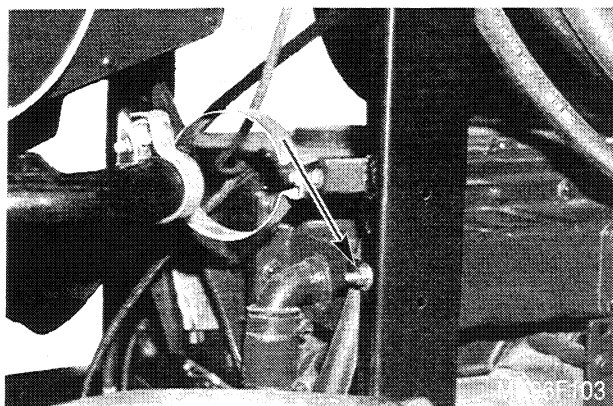

Remove the heater hose clamp from the hood support bracket.

STEP 52

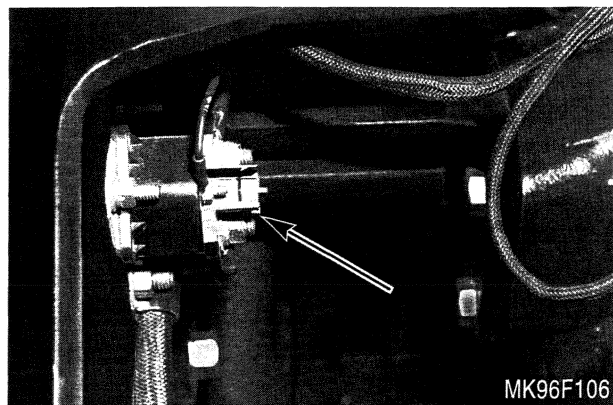

Remove the cover from the magnetic starter switch.

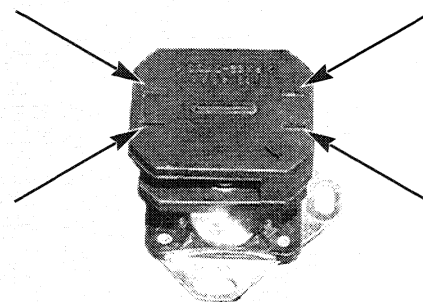

MK96F120

NOTE: Insert a thin blade screwdriver into the slots in the cover to release the cover lock tabs.

STEP 53

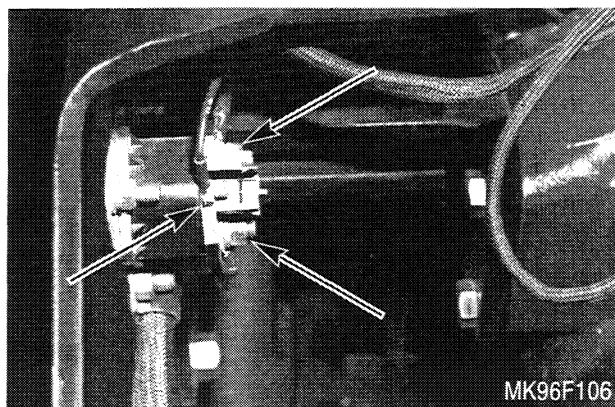

Remove the wires from the magnetic starter switch.

STEP 54

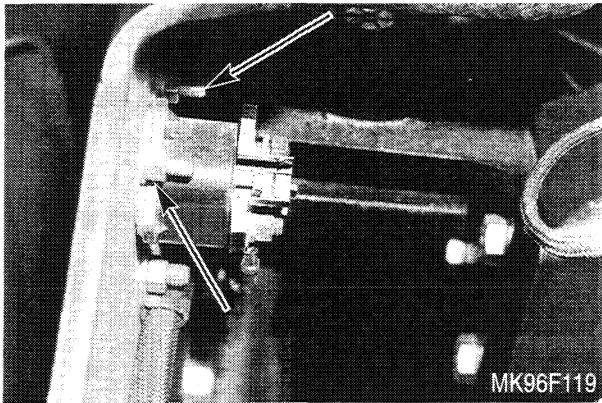

Remove the two mounting bolts and remove the starter switch from the frame.

STEP 55

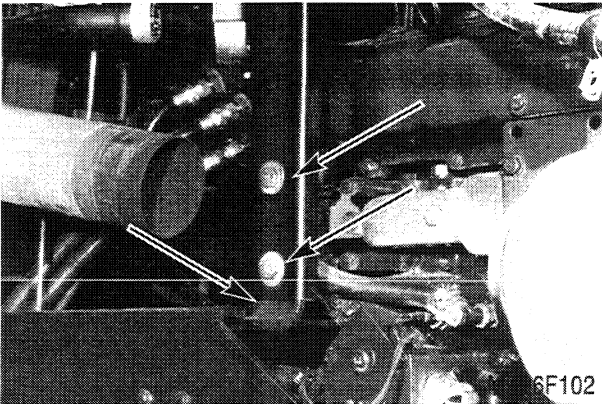

Mark the position of the hood support on the frame brackets. Remove the four hood support mounting bolts, washers and lock nuts. Remove the hood support.

STEP 56

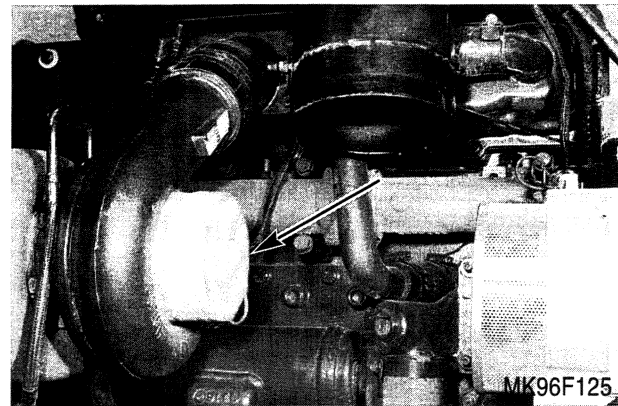
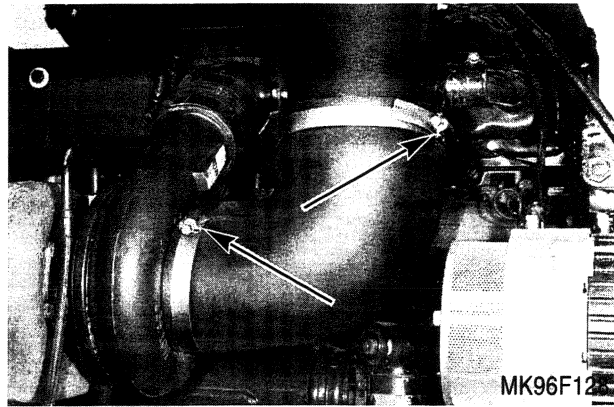

Remove the turbocharger inlet elbow. Cover the inlet opening to prevent any contaminants to enter the turbocharger.

STEP 57

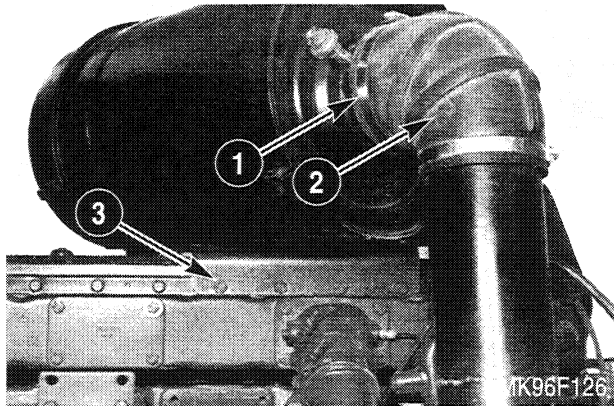

Loosen the clamp (Item 1) and remove the air cleaner outlet elbow and tube (Item 2). Remove the mounting bolts (Item 3) and remove the air cleaner assembly.

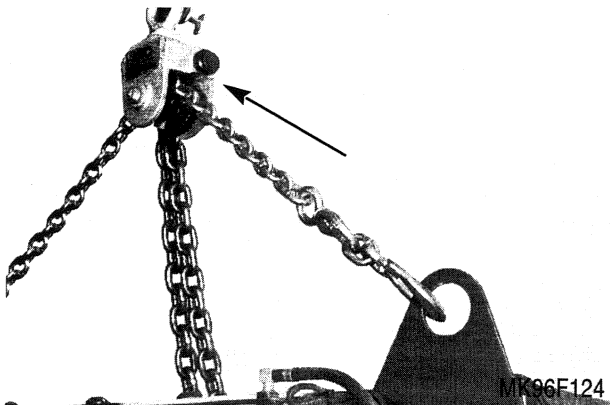
STEP 58

Use OEM 4225 4000 lb (1840 kg), or larger, load rotor onto an overhead hoist. Connect the ends to the front and rear engine lift brackets.

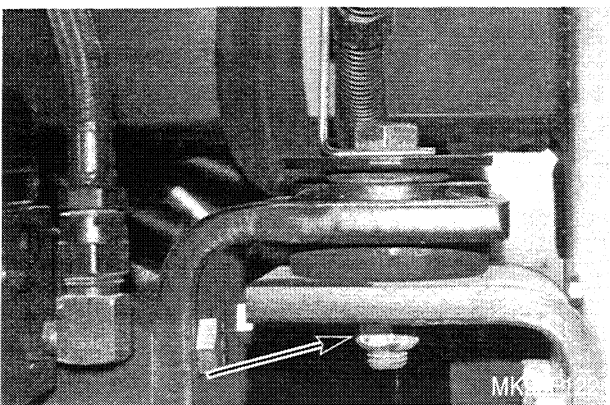
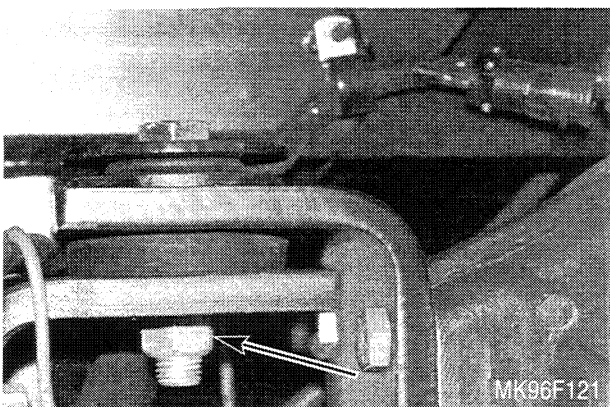
STEP 59

Remove the engine LH and RH side rear vertical mounting bolts, washers and nuts.

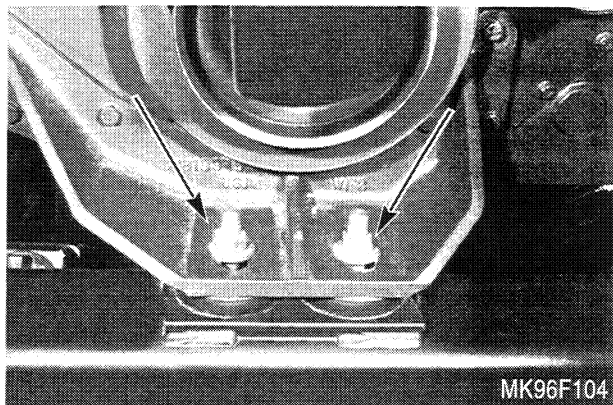
STEP 60

Remove the engine front mounting bolts, washers and nuts.

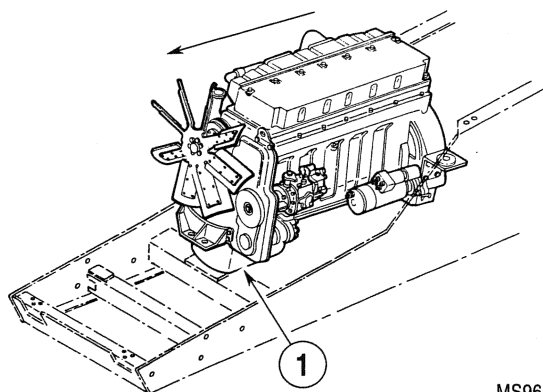
STEP 61

Lift the engine to remove the weight on the motor mounts. Be sure all hoses, lines, cables and wire harnesses are disconnected and clear of the engine. Move the engine forward as it is lifted out of the frame. Use the load rotor to tilt the front of the engine enough for the oil pan (Item 1) to clear the front frame crossmember.



Suggest:

If the above button click is invalid.

Please download this document

first, and then click the above link

to download the complete manual.

Thank you so much for reading

ENGINE INSTALLATION

STEP 62

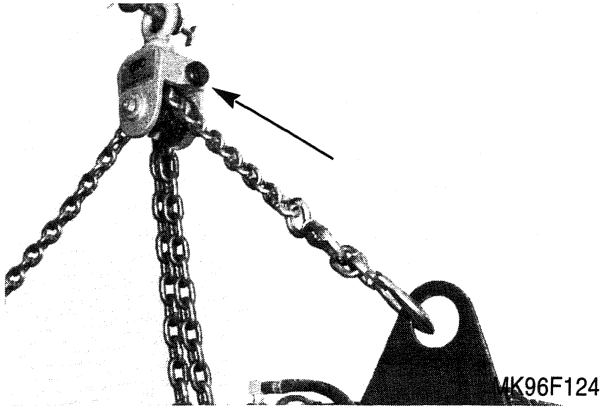

Use OEM 4125 4000 lb (1840 kg), or larger, load rotor on an overhead hoist. Connect the lifting chains to the front and rear engine lift brackets.

STEP 63

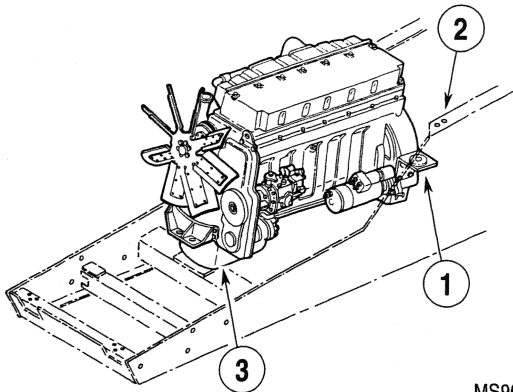

Lift the engine over the front frame crossmember. Move the engine rearward while lowering the engine. Tilt the front of the engine upward to allow the rear engine mounts (Item 1) to pass under the top flanges (Item 2) of the side frames as the oil pan passes over the front frame crossmember (Item 3).

STEP 64

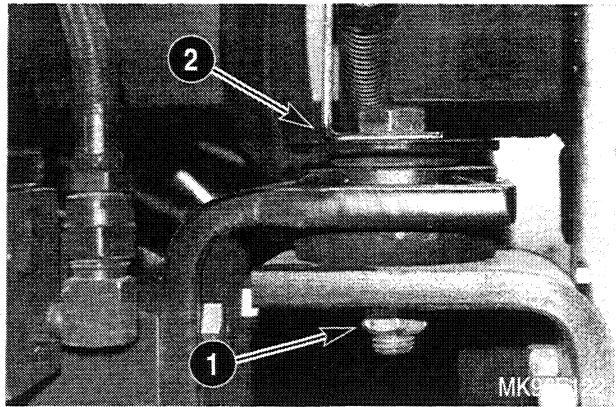
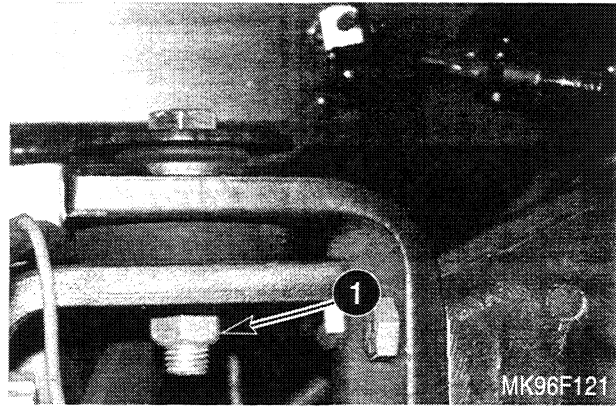

Guide the driveshaft into the engine drive coupler as the engine is moved rearward to align the motor mounts. Lower the engine onto the mounts and install the LH and RH rear vertical mounting bolts, washers and nuts (Item 1). Do not tighten the bolts.

NOTE: The battery cable and fuel line support bracket (Item 2) must be installed with the LH rear engine mount bolt.

<https://www.ebooklibonline.com>

Hello dear friend!

Thank you very much for reading.

Enter the link into your browser.

The full manual is available for immediate download.

<https://www.ebooklibonline.com>