

7100 and 7200 Series Tractor Service Manual Table of Contents

Description	Section No.	Form No.
General		
Tab 1		
General Information - 7100 Series	1001	8-91581
General Information - 7200 Series	1002	7-60490
Engines		
Tab 2		
Engine Troubleshooting	2001	8-91600
Engine Tune-up	2002	8-91611
Engine Removal	2003	8-91621
Tractor Split between Engine and Speed Transmission	2004	8-91631
Tractor Split between Flywheel Housing and Speed Transmission for 7100 Series Transmission S/N AJB0055133 and After and all 7200 Series	2004	7-61090
Air Induction System	2010	8-91691
Aftercooler System	2011	8-91701
Specification Details	2403	8-28424
Cylinder Head and Valve Train	2415	8-28432
Cylinder Block	2425	8-28442
Lubrication System	2445	8-28452
Cooling System	2455	8-28462
Turbocharger	2465	8-28470
Turbocharger Failure Analysis	2565	9-78235
Fuel System		
Tab 3		
Fuel System Specifications	3001	8-91591
Fuel Tank	3004	8-91752
Fuel System and Filters	3410	8-28480
Injection Pump	3412	8-28492
Fuel Injectors	3413	8-28501
Electrical		
Tab 4		
Wiring Schematics and Troubleshooting - 7100 Series	4001	8-91764
Wiring Schematics and Troubleshooting - 7200 Series	4002	7-60450
Alternator	4004	8-91793
Neutral Start Switch	4005	8-91801
Starting Motor - Nippondensa 12800 - 5330	4011	8-95970
Starting Motor - Nippondensa 12800 - 4341	4230	8-25980
Battery Servicing and Testing	4235	8-20291
Steering		
Tab 5		
Steering Column and Hand Pump	5001	8-91822
Steering Cylinder - 2WD and MFD Tractors	5002	8-91832
Steering Axle and Lines - 2WD	5003	8-91840

CASE CORPORATION
700 STATE STREET
RACINE, WI 53404 U.S.A.

Reprinted

Description	Section No.	Form No.
Power Train	Tab 6	
Tractor Split between Speed and Range Transmission	6001	8-91851
Tractor Split for Speed Transmission Service, 7100 Series		
Transmission S/N AJB0055133 and After and all 7200 Series	6001	7-60630
Tractor Split between Range Transmission and Rear Housing	6002	8-91861
Tractor Split for Pinion Shaft or Range Transmission Service - 7100 Series Transmission S/N AJB0055133 and After and all 7200 Series	6002	7-60720
MFD Axle Removal	6003	8-91871
Transmission Valve - Prior to Transmission S/N AJB0055133	6004	8-91882
Transmission Valve - Transmission S/N AJB0055133 and After	6004	7-60330
Speed Transmission	6005	8-91891
Speed Transmission - 7100 Series Transmission S/N AJB0055133 and After and all 7200 Series	6005	7-60620
Range Transmission	6006	8-91901
Range Transmission - 7100 Series Transmission S/N AJB0055133 and After and all 7200 Series	6006	7-60610
Hydraulic Pump Drive	6007	8-91911
Rear Frame	6008	8-91922
Rear Axle and Planetaries	6009	8-91932
PTO - Single Shaft for Models 7130 and 7140 Prior to Transmission S/N AJB00059710 and Dual Shaft PTO for all 7110 and 7120 Models	6010	8-91942
PTO - Single Shaft for 7130 and 7140 Models Transmission S/N AJB00059710 and After, All Models 7150, 7230, 7240 and 7250. Dual Shaft for all 7210 and 7220 Models	6010	7-60250
MFD Clutch Removal without Tractor Split	6011	7-60770
MFD Differential	6012	8-91961
MFD Axle and Planetaries	6013	8-91972
Brakes	Tab 7	
Brake Valve	7001	8-91981
Brake Cylinders	7003	8-91952
Hydraulics	Tab 8	
Hydraulic Troubleshooting - 7100 and 7200 Series	8001	8-92013
PTO Valve	8002	8-92021
Electrical PTO Valve	8002	7-65430
Remote Hydraulic Circuits	8004	8-92042
Hydraulic Filters - 7100 Series	8005	8-92051
Hydraulic Filters - 7200 Series	8005	7-60780
Differential Lock and MFD Solenoid Valves	8006	8-92060
Charge and Lube Pump - 7100 Series	8007	8-91811
Charge and Lube Pump - 7200 Series	8007	7-61040
Hydraulic Pump	8008	8-91990
Electronic Hitch Alignment - 7100 Series	8009	8-92071
Electronic Hitch Alignment - 7200 Series	8009	7-60420
Three Point Hitch	8010	8-92082
Hitch Valve	8011	8-92091
Hydraulic Schematics - 7100 and 7200 Series	8012	8-94382
Hydraulic Couplers	8013	8-95330

Description	Section No.	Form No.
Chassis	Tab 9	
Air Conditioning Troubleshooting - 7100 Series	9001	8-92101
Air Conditioning Troubleshooting - 7200 Series	9001	7-60380
Air Conditioning Testing - 7100 Series	9002	8-92111
Air Conditioning Testing - 7200 Series	9002	7-60390
Air Conditioning System and Compressor - 7100 Series	9003	8-92121
Air Conditioning System and Compressor - 7200 Series	9003	7-60400
Air Conditioning Components - 7100 Series	9004	8-92131
Air Conditioning Components - 7200 Series	9004	7-60410
Cab Blower	9005	8-92141
Tractor Seat - Air/Oil	9006	8-92151
Hood, Grille and Side Panels - Radiator and Support	9007	8-92161
Decal Location - 7100 Series	9008	8-92170
Decal Location - 7200 Series	9008	7-60820
Cab Removal	9009	8-92180
Pedal and Lever Adjustment	9010	8-92192
Tractor Seat - Air/Air - 7100 Series	9011	8-95560
Tractor Seat - Air/Air - 7200 Series	9011	7-60910

<https://www.ebooklibonline.com>

Hello dear friend!

Thank you very much for reading.

Enter the link into your browser.

The full manual is available for immediate download.

<https://www.ebooklibonline.com>

Section 1001

GENERAL INFORMATION

FLUID CAPACITIES AND TYPES

Engine Crankcase Capacity, Refill.....	20 Litres
New	22 Litres
Fluid Type.....	Case No. 1 Multi-Viscosity Engine Oil
Transmission/Hydraulic System Capacity, Refill	162 Litres
New	191.2 Litres

Fluid Type..... Hy-Tran Plus ® Fluid

Differential Housing Capacity - MFD	11 Litres
Planetary Housing Capacity - MFD (Each)	1 Quart (0.9 Litres)
Fluid Type.....	Case 135H EP Gear Lubricant
	Use one pint of Limited Slip additive in the differential

Cooling System Capacity.....	28.4 Litres
Fluid Type.....	50 Percent Ethylene Glycol Coolant

ENGINE SPEEDS

Governed Engine Speed without Load.....	2315 to 2395 RPM
Rated Engine Speed	2200 RPM
Engine Idle Speed	825 to 875 RPM

NUMBER OF TEETH ON THE FLYWHEEL..... 137

FUSES

Dome Lamp and Radio Clock	5 Amp
Fuel Shut Off	5 Amp
Shut Down Override	15 amp
Instrument Cluster - Run Position	7.5 Amp
Instrument Cluster - Accessory Position	5 Amp
Radio	5 Amp
Electronic Hitch System	7.5 Amp
Cigar Lighter	10 Amp
Ether Starting Aid	15 Amp
Differential Lock	10 Amp
Tail Lamps	10 Amp
Warning Lamps	15 Amp
Cab Roof Work Lamps	15 Amp
Mechanical Front Drive (If equipped)	7.5 Amp
Creeper Drive (If equipped)	7.5 Amp

BULB AND LAMP REPLACEMENT

Dome Lamp Bulb	No. 3050958R1
Console Lamp Bulb.....	No. 194
Flasher Lamp Bulb	No. 1156
Head Lamps.....	No. H3 and H4
Front and Rear Flood Lamps.....	No. H3
Tail Lamp Bulbs	No. 168
Rocker Switch Bulb	No. 3141107R1
Three Point Hitch Indicator Bulb	No. 182

STEERING AND OSCILLATION STOPS - MFD

Tractors with mechanical front drive (MFD) are equipped with steering and oscillation stops. The steering and oscillation stops are used to give the required steering clearance between the front tires and tractor frame. The front tire size and tread width being used, will determine the required steering and oscillation angles.

Steering Stop

Each adjustment hole in the steering stop is identified with an arrow and a number. With the arrow pointing toward the wheel, the number indicates the turn angle when the mounting pin is installed in that hole. The steering stop can be installed in either direction depending on the tire size and tread width being used. See Steering and Oscillation Stop Charts for more information.

NOTE: The numbers shown in the hole outlines indicates the steering angle in degrees for that hole when installed in that direction.

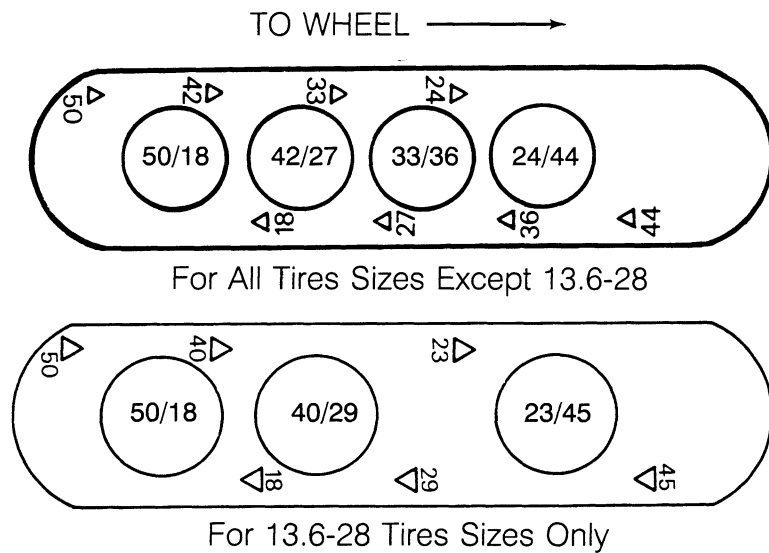
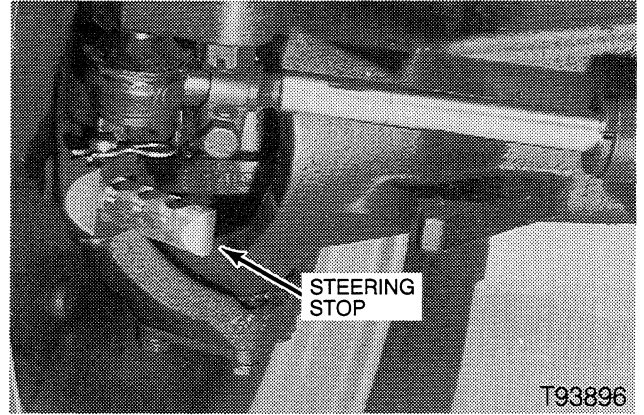

T93896

Oscillation Stop

Oscillation stops are required for some tire size and tread width combinations. The oscillation stops are installed on the axle stop pad on each side of the tractor.

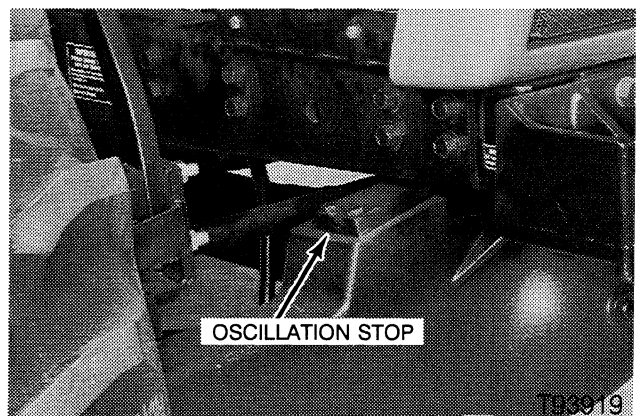

Steering and Oscillation Stop Charts

The following charts show the steering stop turn angle and oscillation stop requirement for each tread width and tire size combination for tractors without fenders and with fenders.

TRACTORS EQUIPPED WITH 26 INCH (660 mm) DIAMETER WHEEL

STEERING STOP AND OSCILLATION STOP POSITIONS- W/O FENDERS									
TIRE SIZE	TYPE STOP	TREAD WIDTHS (INCHES)							
		62.1	66.5	71.3	75.8	79.1	83.5	88.3	92.8
18.4-26	A	N.A.	27	33	42	50	50	50	50
	B	N.A.	YES	YES	YES	YES	NO	NO	NO
16.9-26	A	24	33	44	50	50	50	50	50
	B	YES	YES	YES	YES	NO	NO	NO	NO

STEERING STOP AND OSCILLATION STOP POSITIONS- WITH FENDERS									
TIRE SIZE	TYPE STOP	TREAD WIDTHS (INCHES)							
		62.1	66.5	71.3	75.8	79.1	83.5	88.3	92.8
18.4-26	A	N.A.	N.A.	27	36	36	44	44	50
	B	N.A.	N.A.	YES	YES	YES	NO	NO	NO
16.9-26	A	24	27	27	36	36	44	44	50
	B	YES	YES	YES	YES	NO	NO	NO	NO

TRACTORS EQUIPPED WITH 28 INCH (711 mm) AND 30 INCH (762 mm) DIAMETER WHEEL

STEERING STOP AND OSCILLATION STOP POSITIONS- W/O FENDERS									
TIRE SIZE	TYPE STOP	TREAD WIDTHS (INCHES)							
		60.1	64.5	69.3	73.8	81.1	85.5	90.3	94.8
13.6-28	A	29	40	45	50	50	50	50	50
	B	YES	YES	YES	NO	NO	NO	NO	NO
14.9-28	A	24	36	42	50	50	50	50	50
	B	YES	YES	YES	YES	NO	NO	NO	NO
16.9-28	A	18	27	36	42	50	50	50	50
	B	YES	YES	YES	YES	NO	NO	NO	NO
14.9-30	A	24	33	42	50	50	50	50	50
	B	YES	YES	YES	YES	NO	NO	NO	NO

STEERING STOP AND OSCILLATION STOP POSITIONS- WITH FENDERS									
TIRE SIZE	TYPE STOP	TREAD WIDTHS (INCHES)							
		60.1	64.5	69.3	73.8	81.1	85.5	90.3	94.8
13.6-28	A	23	23	29	29	40	45	50	50
	B	YES	YES	YES	NO	NO	NO	NO	NO
14.9-28	A	24	24	27	36	42	44	50	50
	B	YES	YES	YES	YES	NO	NO	NO	NO
16.9-28	A	18	24	27	36	42	44	50	50
	B	YES	YES	YES	YES	NO	NO	NO	NO
14.9-30	A	24	24	27	36	42	44	50	50
	B	YES	YES	YES	YES	NO	NO	NO	NO

Type Stop A = Steering Stop Angle Number Type Stop B = Oscillation Stop Required

NOTE: N.A. indicates that the tread width is not approved for these tire sizes because of clearance requirements.

TIRE SPECIFICATIONS

TIRE SIZE	TIRE RATING	TREAD TYPE	INFLATION PRESSURE
-----------	-------------	------------	--------------------

Front Tires - Two Wheel Drive

11.0-16	8 PLY	F2M	40 PSI (276 kPa)
11.0-16	12 PLY	F2M	60 PSI (414 kPa)
14L-16.1	6 PLY	F2M	28 PSI (193 kPa)
14L-16 1	10 PLY	F2M	44 PSI (303 kPa)
16.5L-16.1	8 PLY	F2M	32 PSI (221 kPa)

Front Tires - Mechanical Front Drive (MFD)

13.6-28	10 PLY	R1	36 PSI (248 kPa)
13.6R-28	3 STAR	R1	30 PSI (207 kPa)
14.9-28	6 PLY	R1	20 PSI (138 kPa)
14 9-28	10 PLY	R1	32 PSI (221 kPa)
14.9R-28	3 STAR	R1	30 PSI (207 kPa)
14.9-30	10 PLY	R1	32 PSI (221 kPa)
16.9-26	6 PLY	R1 & R2	18 PSI (124 kPa)
16.9-26	10 PLY	R1 & R2	28 PSI (193 kPa)
16.9R-26	2 STAR	R1	24 PSI (165 kPa)
16.9-28	6 PLY	R1	18 PSI (124 kPa)
16.9R-28	2 STAR	R1	24 PSI (165 kPa)
18.4-26	6 PLY	R1	16 PSI (110 kPa)
18.4-26	10 PLY	R2	26 PSI (179 kPa)
18.4R-26	2 STAR	R1	30 PSI (207 kPa)

TIRE SIZE	TIRE RATING	TREAD TYPE	INFLATION PRESSURE
-----------	-------------	------------	--------------------

Rear Tires

16.9-38	8 PLY	R1	16 to 24 PSI (110 to 165 kPa)
18.4-38	8 PLY	R1 & R2	16 to 20 PSI (110 to 138 kPa)
18.4R-38	1 STAR	R1 & R2	16 to 18 PSI (110 to 124 kPa)
18.4-38	10 PLY	R1 & R2	16 to 26 PSI (110 to 179 kPa)
18.4-38	8 PLY	R1 & R2	12 to 16 PSI (83 to 110 kPa)
18.4-42	8 PLY	R1	16 to 20 PSI (110 to 138 kPa)
18.4-42	10 PLY	R1	16 to 26 PSI (110 to 179 kPa)
18.4R-42	2 STAR	R1	16 to 24 PSI (110 to 165 kPa)
20.8-38	8 PLY	R1 & R2	16 to 18 PSI (110 to 124 kPa)
20.8R-38	1 STAR	R1 & R2	16 to 18 PSI (110 to 124 kPa)
23.1-34	8 PLY	R1	16 PSI (110 kPa)
24.5R-32	1 STAR	R1	18 PSI (124 kPa)



Do not remove, install or make repairs to a tire on a rim. Take the tire and rim to a tire shop where persons with special training and special safety tools are available. If the tire is not in correct position on the rim, or if too full of air, the tire bead can loosen on one side and cause air to leak at high speed and with large force. Because the air leak can thrust the tire in any direction, and with much force, you will be in danger of injury.

M169A

Section 2002

2002

ENGINE TUNE UP

IMPORTANT: This engine was made using the metric measurement system. All measurements and checks must be made with metric tools to make sure of an accurate reading when inspecting parts.

ADJUSTING ROCKER ARM TO VALVE CLEARANCE Cold Setting

STEP 1

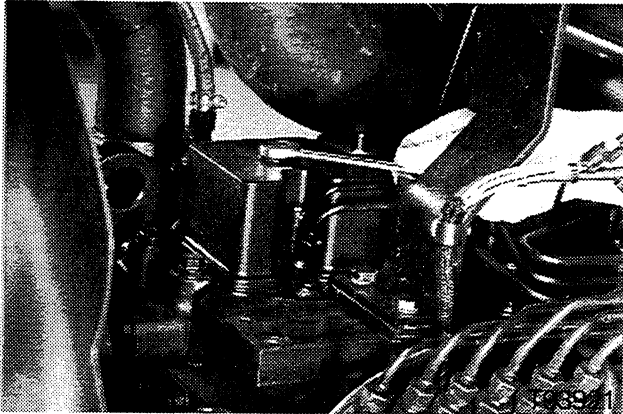

Remove the valve cover from the engine. Discard the gasket.

STEP 2

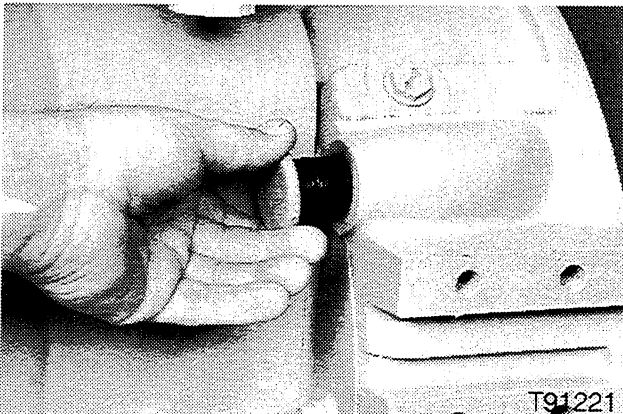

Remove the plug in the flywheel housing (if equipped) and install the engine turnover tool, CAS-1690.

STEP 3

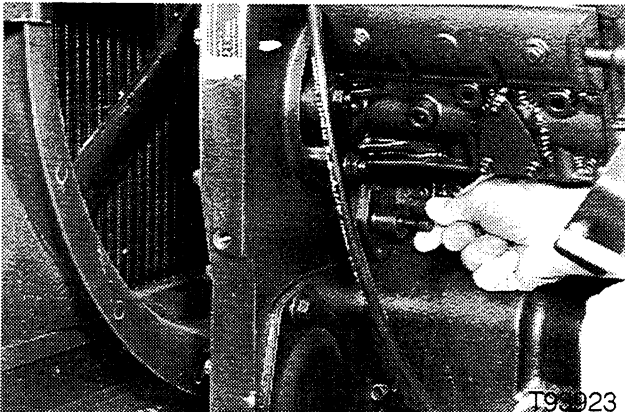

While turning the engine over with the turn over tool, push the lock pin in. When the lock pin moves into the camshaft gear, the engine will be at top center.

NOTE: Use caution when turning the engine to prevent damage to the timing pin.

STEP 4

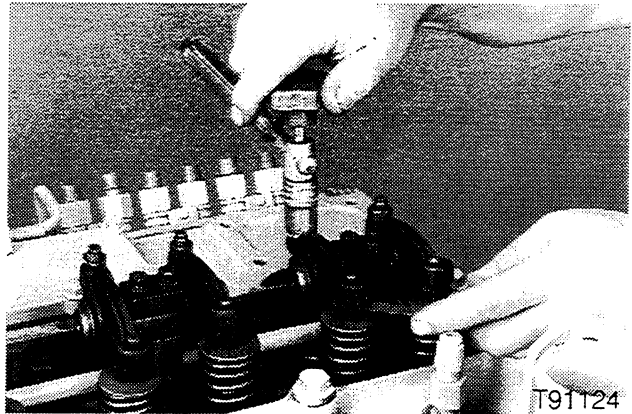

Check and adjust the intake and exhaust valves indicated by the arrows shown below.

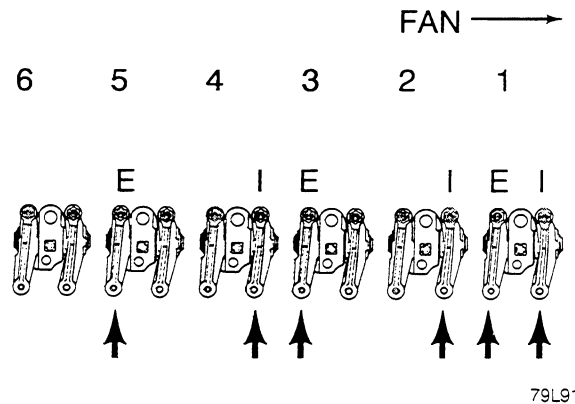

79L91

Number one cylinder will be at top center of the compression stroke.

Valve Clearance, Cold - Intake Valves - 0.30 mm
Exhaust Valves - 0.60 mm

STEP 5

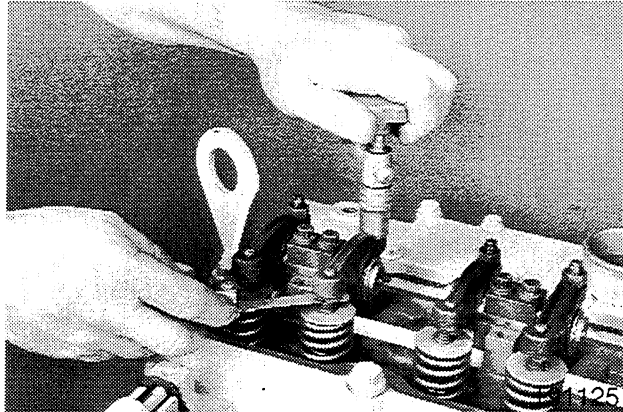

Put a mark on the crankshaft pulley and the cylinder block, in alignment. Pull the lock pin from the cam gear. Turn the engine one complete revolution. Make sure the marks are aligned again.

Check and adjust the intake and exhaust valves indicated by the arrows shown below

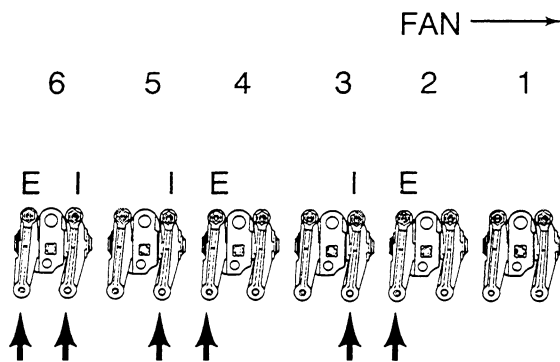

79L91

Number six cylinder will be at top center of the compression stroke

Valve Clearance, Cold - Intake Valves - 0.30 mm
 Exhaust Valves - 0.60 mm

STEP 6

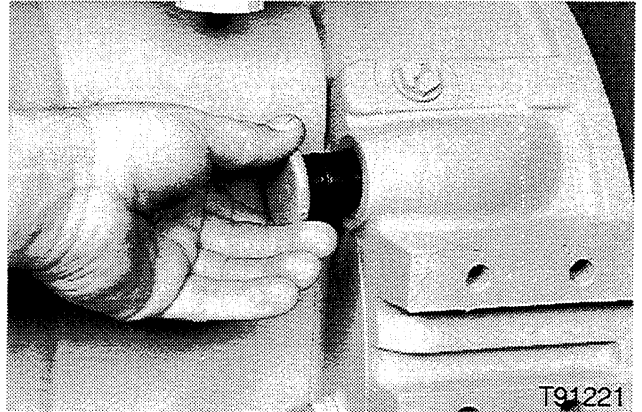

Remove the engine turn over tool and install the plug in the flywheel housing (if equipped).

STEP 7

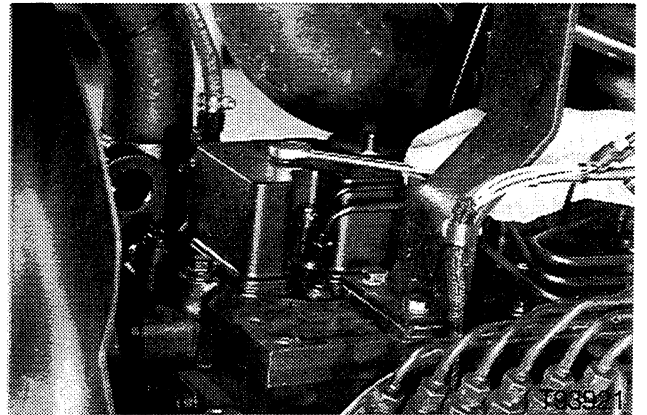

Install a new gasket and the valve cover on the engine. Tighten the valve cover mounting bolts to a torque of 21 to 27 Nm. Install the breather tube on the valve cover.

CRANKCASE PRESSURE CHECK (BLOW BY) Manometer Installation

STEP 8

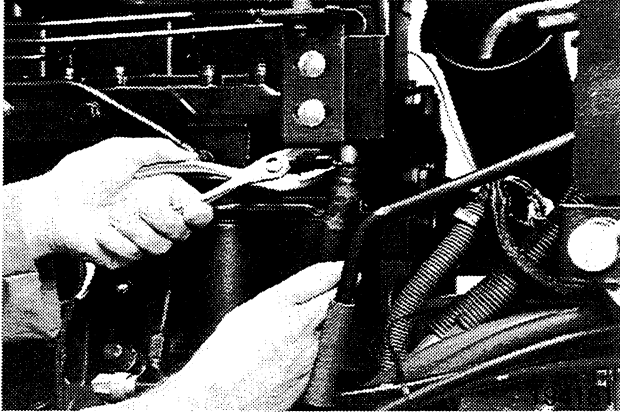

Remove the breather hose.

STEP 9

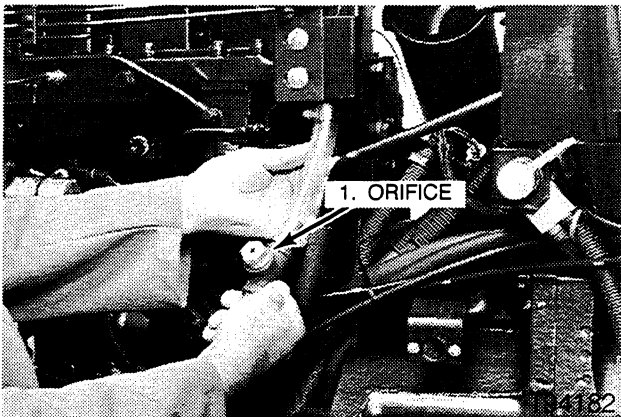

Install the breather adapter with the six cylinder orifice from the CAS-1692 manometer package.

NOTE: Use the orifice for six cylinder engines, marked 6 cyl.

STEP 10

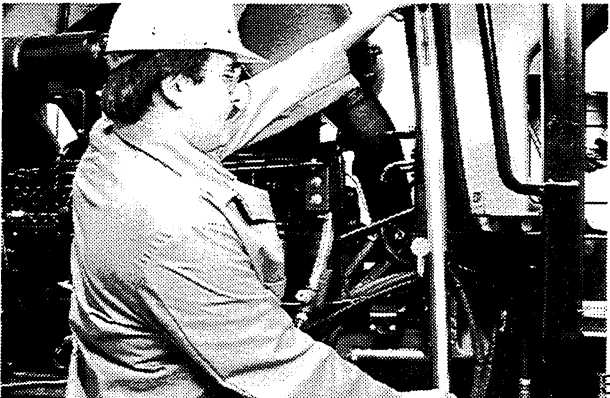

Install the manometer on the tractor.

STEP 11



Turn each connector on the manometer one turn counterclockwise to open the check valves.

STEP 12



Connect the tube from the breather adapter to one of the connectors on the manometer.

STEP 13

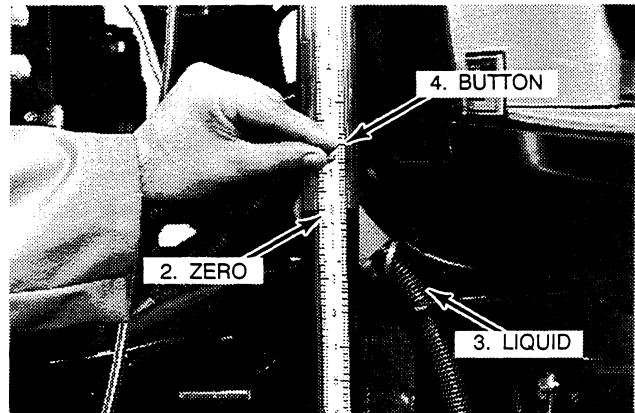

Push the button on the gauge and move the gauge up or down, until the zero on the gauge and the liquid in the tube are aligned.

Testing

NOTE: Do the following steps to get the correct manometer readings.

Step 1 - Warm the engine to operating temperature.

Step 2 - Operate the engine at the rated speed, under a full load

STEP 14

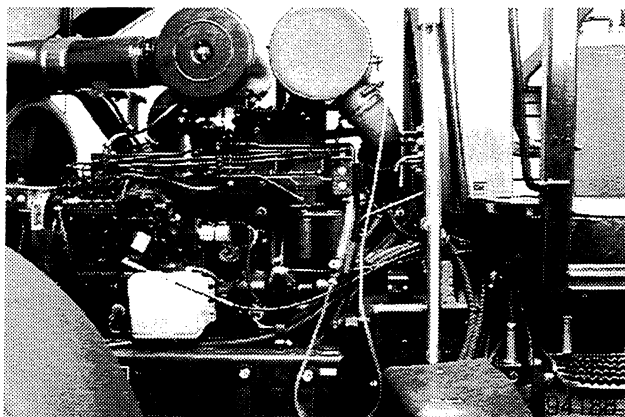

Take a manometer reading from the engine. Add the number of lowered inches to the number of raised inches for the correct manometer reading. See example below.

LOWERED INCHES	1.5	
RAISED INCHES	+ 1.5	
		3.0 INCHES
TOTAL		

See the chart for manometer reading and crankcase pressure (Blow By) limits

MANOMETER READING

Inches of Water	L/min
1	50
2	84
3	103
4	119
5	133
6	145
7	155
8	164
9	172
10	180
11	187
12	193
13	200
14	206
15	211
16	217
17	222
18	226
19	229
20	232

CRANKCASE PRESSURE (BLOW BY) LIMITS

Engine Model	Engine Speed	L/min Maximum New	L/min Worn Limit
6T-830	2200	113.0	226.0
6TA-830	2200	113.0	226.0

Manometer Removal

STEP 15



Disconnect the tube from the connector.

STEP 18

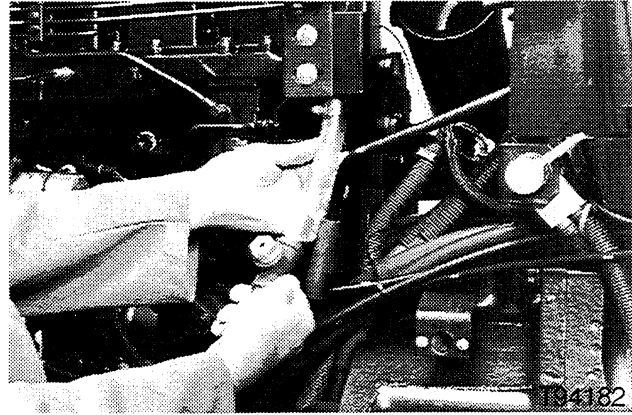

Remove the adapter from the breather tube.

STEP 16



Turn each connector on the manometer one turn clockwise to close the check valve.

STEP 19

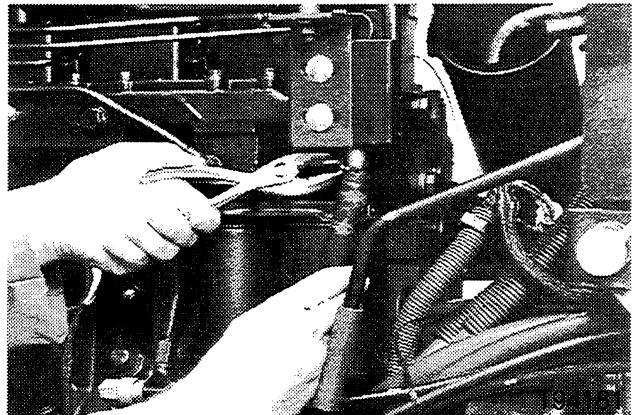

Install breather hose and the hose clamp

STEP 17

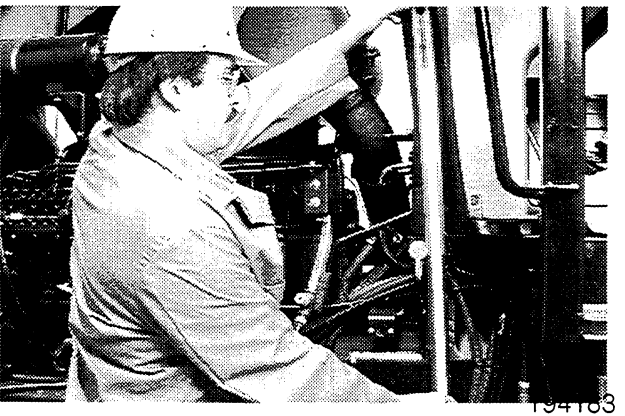

Remove the manometer

Checking the Fan Belt Tensioner

STEP 20

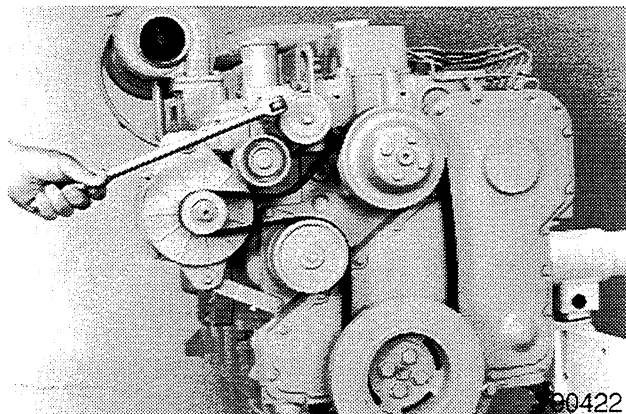

Lift the belt tensioner pulley. If there is tension on the pulley, the tension is good.

If the belt tensioner needs replacement, see Section 2455 in this manual for belt tensioner removal.

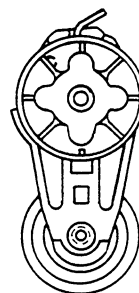

7L91

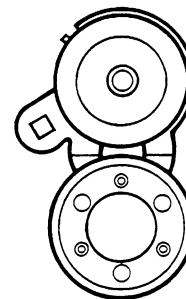

8-1L91

ADJUSTING THE COMPRESSOR BELT

STEP 21

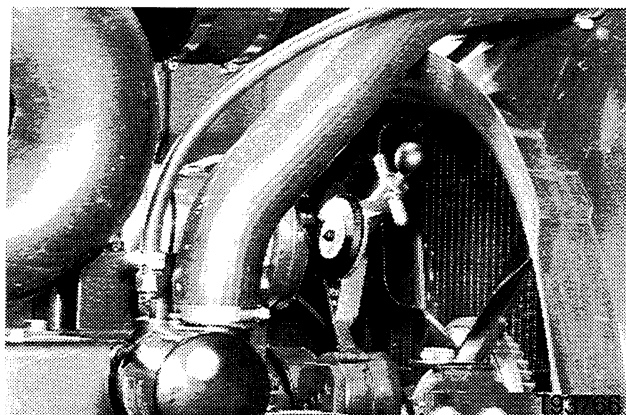

Check the compressor belt for the correct tension using the tension gauge OEM-1294. The belt tension must be 422 to 516 N for a new belt and 400 to 489 N for a used belt. After 10 minutes of run in on a new belt, adjust to used belt specifications

STEP 22

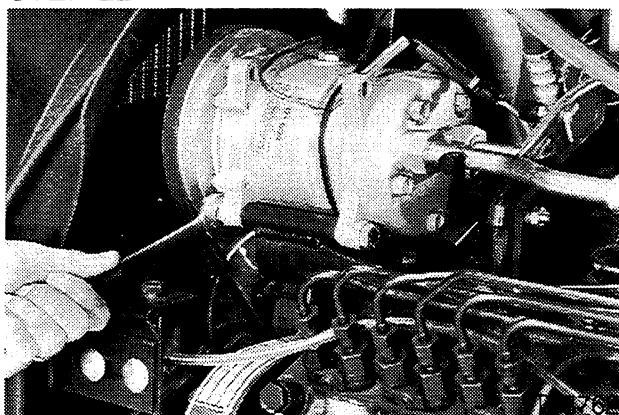

To adjust the compressor belt, loosen the adjusting bolt and pivot bolts. Pull the compressor out from the engine until the correct tension is reached. Tighten the adjusting and pivot bolts.

CHECKING ALIGNMENT BETWEEN CRANKSHAFT AND CAMSHAFT GEARS

STEP 23

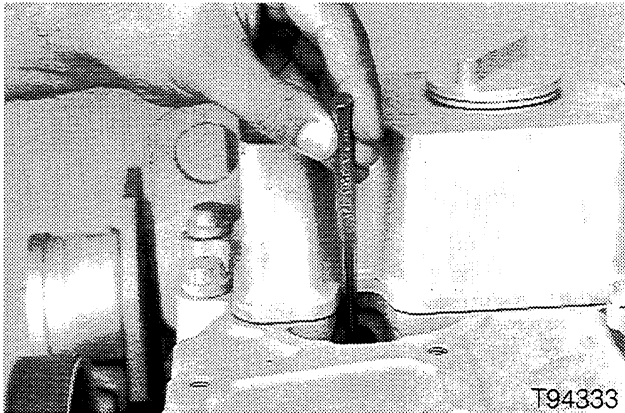

Remove the number one injector. Install a probe (minimum of 250 mm long) in the injector bore so that the probe will touch the top of the piston.

STEP 24



Remove the plug from the flywheel housing (if equipped).

STEP 25

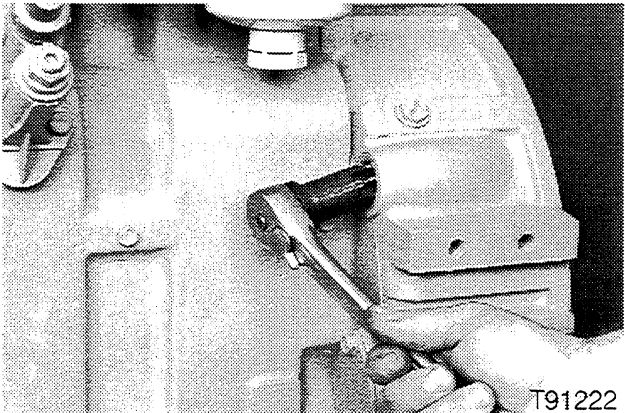

Install the engine turn over tool CAS-1690.

STEP 26

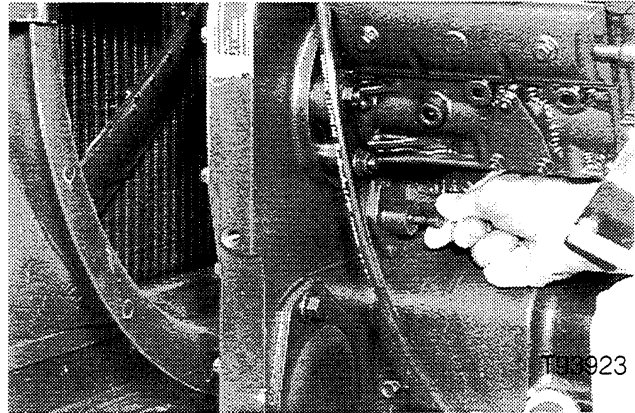

While turning the engine over with the turn over tool, CAS-1690 (if equipped) push the lock pin in. When the lock pin moves into the camshaft gear the engine will be at top center.

NOTE: Use caution when turning the engine to prevent damage to the timing pin.

STEP 27



Pull the timing pin from the cam gear. Turn the engine in either direction a small amount. The probe must go down from this position. If the probe goes up when the engine is turned, timing is not correct. See Section 2425 in this manual for alignment of gears.

STEP 28

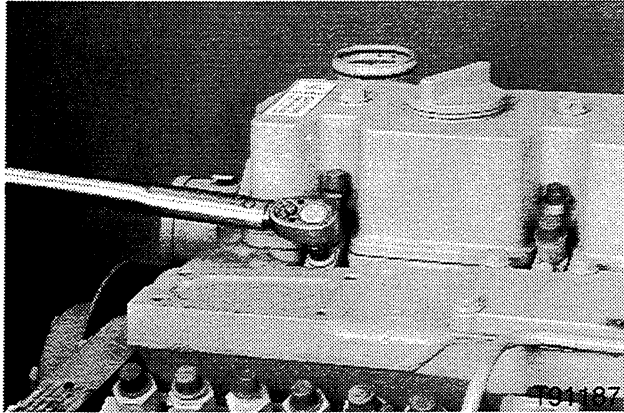

Remove the probe from the injector bore. Install the injector with a new seal. Tighten the retaining bolt to a torque of 21 to 27 Nm.

STEP 30

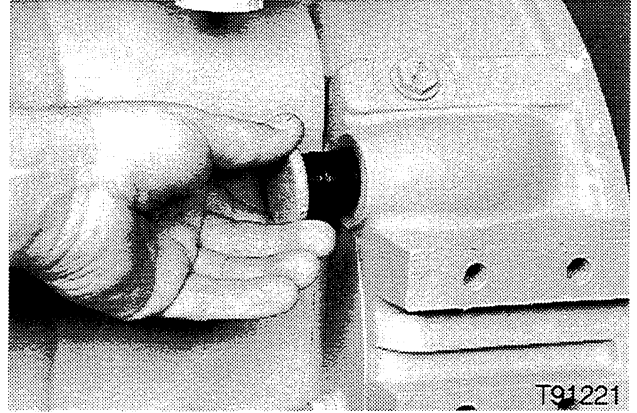

Remove the engine turn over tool and install the plug in the flywheel housing (if equipped).

STEP 29

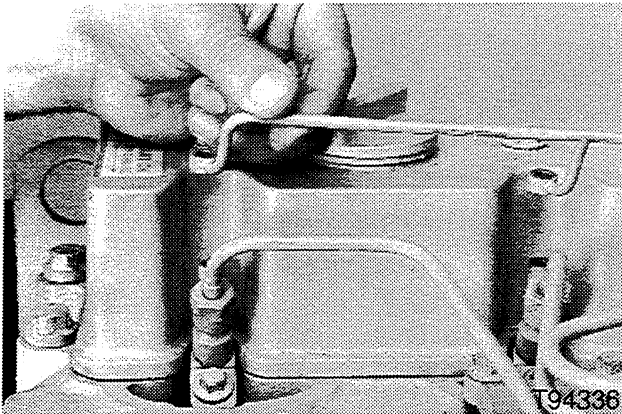

Install the injection line and leak off line. Tighten the leak off line bolts to a torque of 8 to 10 Nm.

NOTE: The CASE CORPORATION reserves the right to make improvements in design or changes in specifications at any time without incurring any obligation to install them on units previously sold.

ENGINE REMOVAL

STEP 1

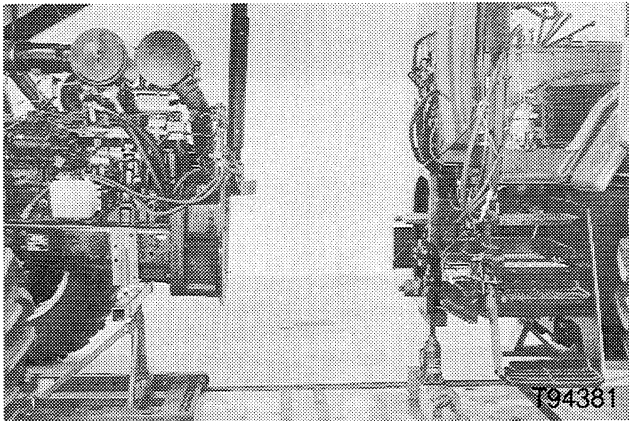

See Section 2004 in this manual and split the tractor between the flywheel housing and the transmission speed housing.

STEP 2

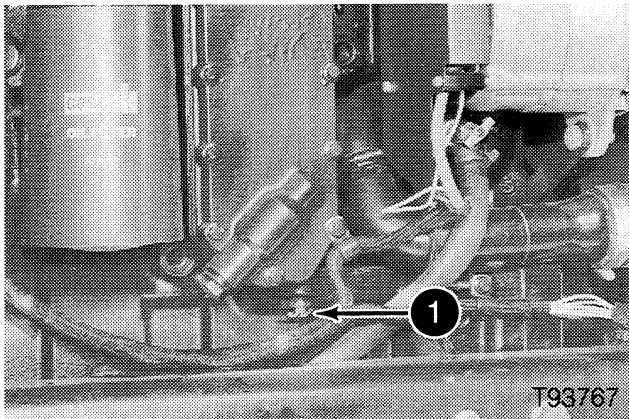

1. Block Drain Valve

Open the valve on the engine oil cooler and drain the coolant from the engine block.

STEP 3

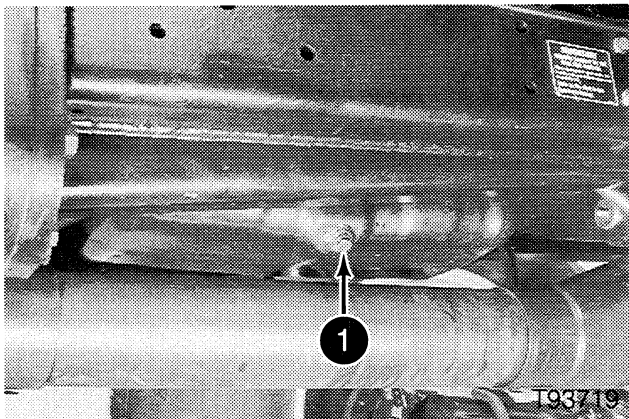

1. Drain Plug

Remove the oil pan drain plug and drain the engine oil.

STEP 4

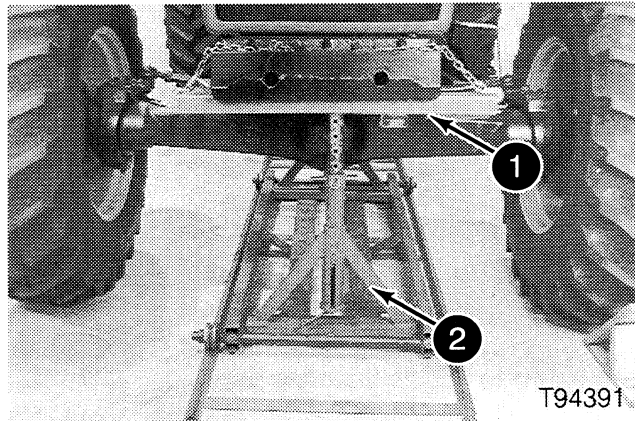

1. Adapter Bar 17-526-4A
2. Support 17-526-5 and Brace 17-526-14

Install a support 17-526-5, brace 17-526-14 and adapter bar from 17-526-4A under the weight carrier. Secure the weight carrier to the support.

STEP 5

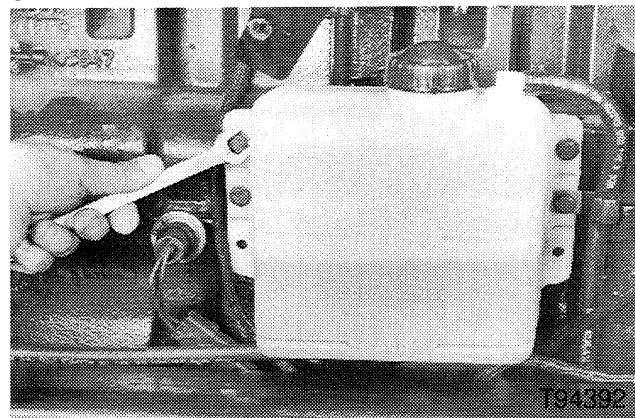

Remove the radiator reservoir from the bracket on the LH side of the engine.

STEP 6

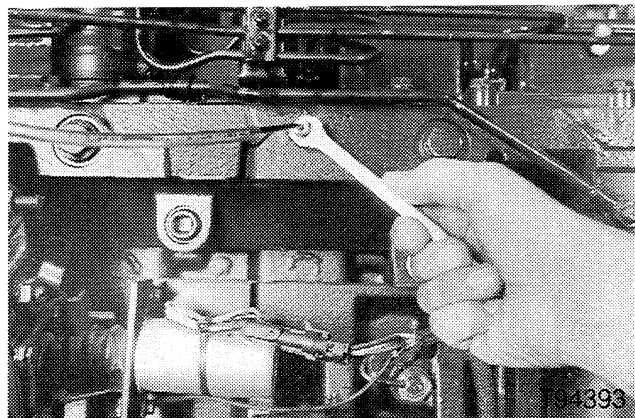

Remove the ether start hose from the fitting on the intake manifold.

STEP 7

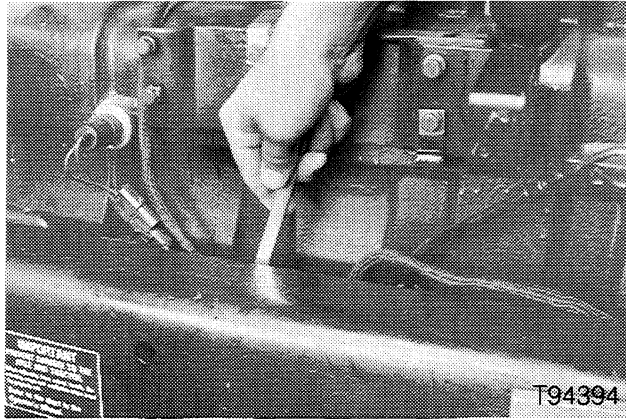

Remove the wiring harness clamp from the inside of the LH side frame.

STEP 10



Remove the exhaust pipe.

STEP 8

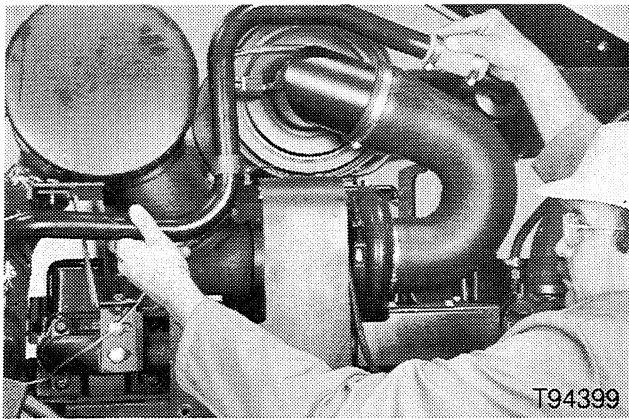

Remove the aspirator tube.

STEP 11

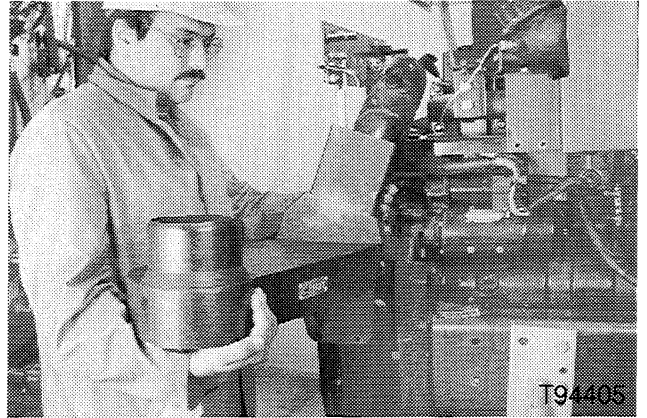

Remove the exhaust elbow and aspirator discharge pipe from the flywheel housing.

STEP 9

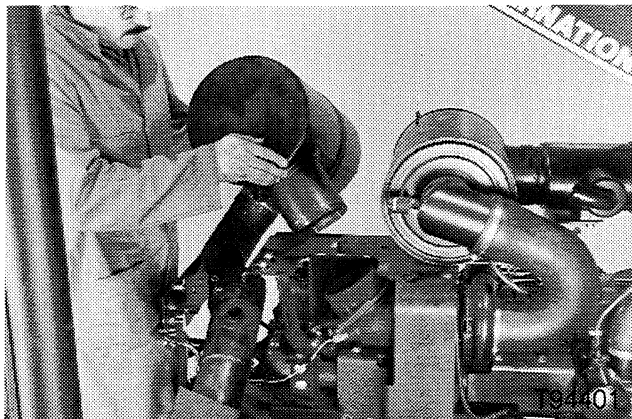

Remove the muffler.

STEP 12

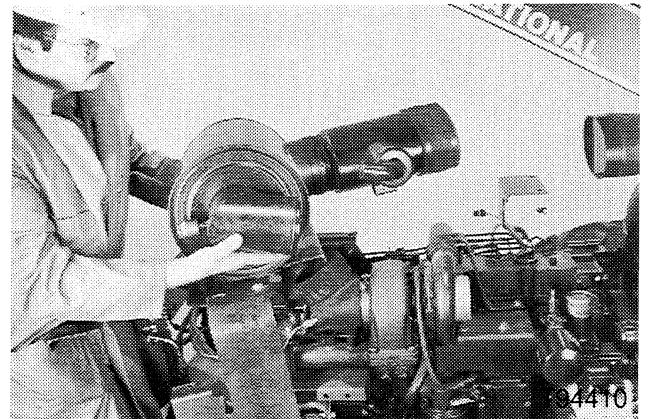

Remove the air cleaner and strata tube from the engine.

STEP 13

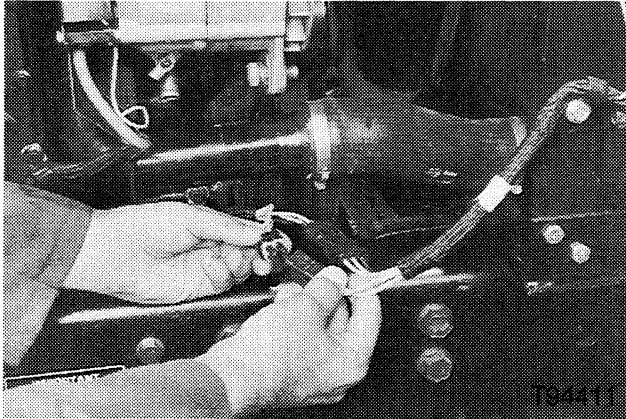

Disconnect the engine wiring harness from the front wiring harness at the RH frame rail.

STEP 14

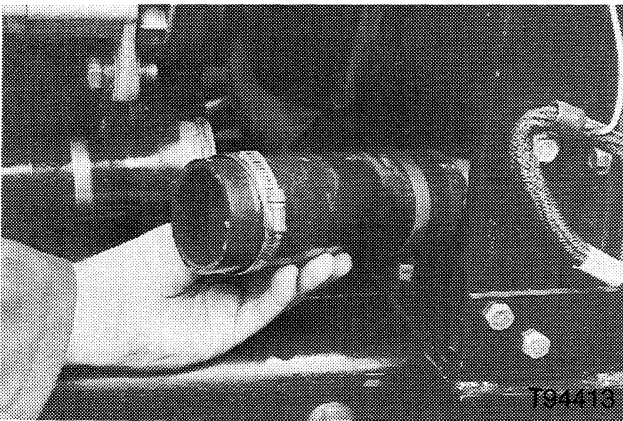

Remove the radiator hoses.

STEP 15

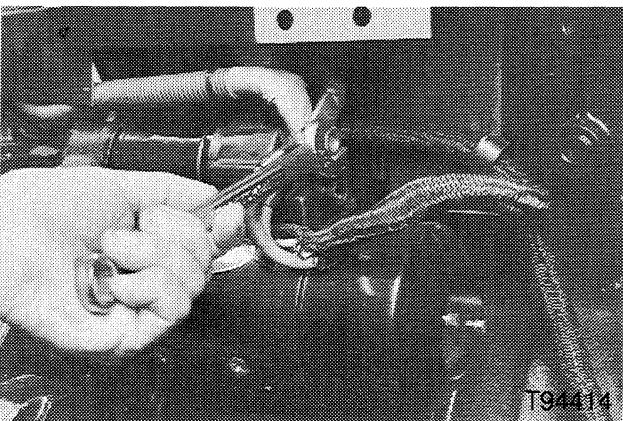

Disconnect the battery cables from the starter.

STEP 16



Remove the hood support and battery cable assembly from the flywheel housing.

STEP 17

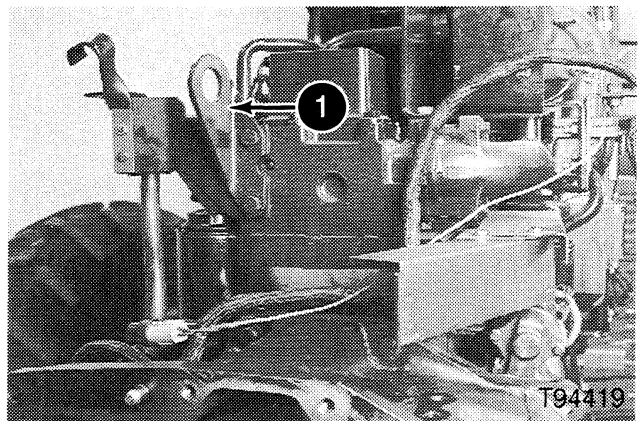

1. Lifting Bracket

Remove the side panel latch mounting bolt from the back of the engine. Move the engine lifting bracket to a vertical position.

STEP 18

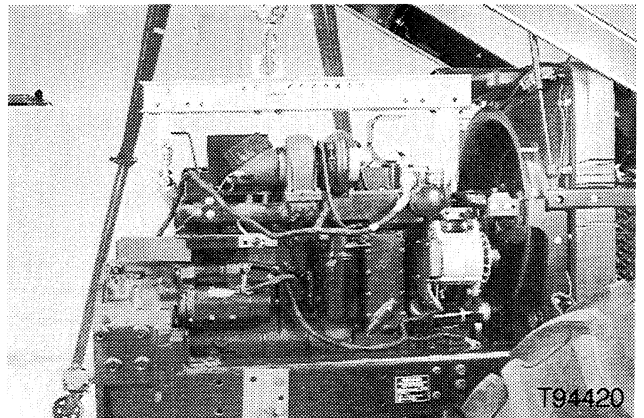

Attach a lifting sling to the engine lifting brackets and support the engine from a hoist.

STEP 19

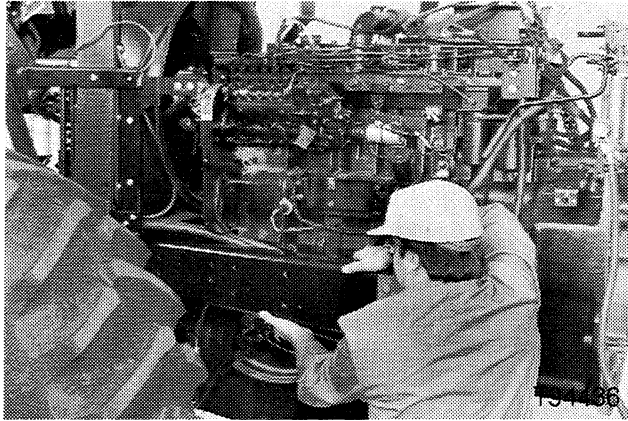

Remove the side frames.

STEP 20

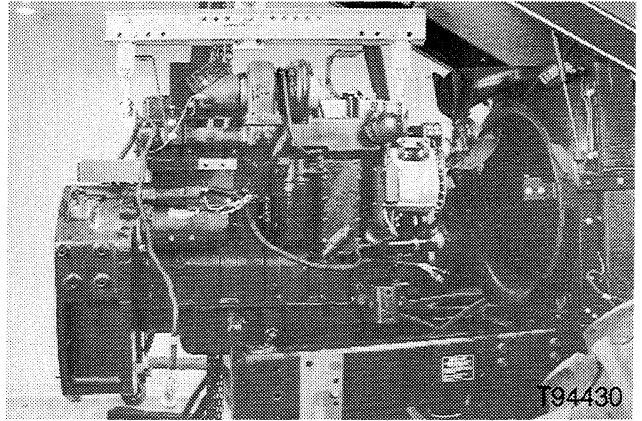

Raise the engine, move the engine to the rear and left to clear the RH side frame.

FLYWHEEL HOUSING REMOVAL

STEP 21

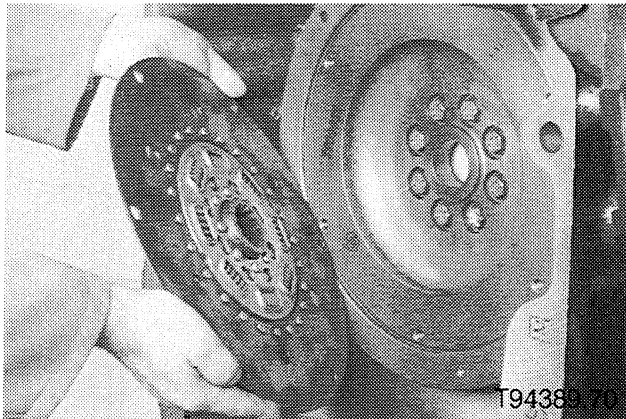

Remove the flex plate from the flywheel. Inspect the flex plate for broken springs or cracks. Replace the flex plate if necessary.

STEP 23

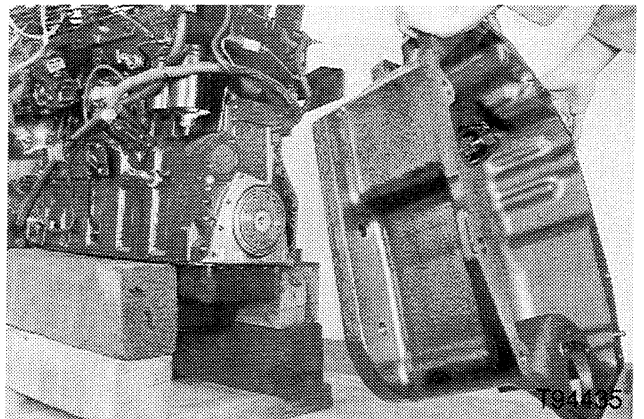

Attach a chain and hoist to the flywheel housing and remove the housing. Install the engine on the engine repair stand.

STEP 22

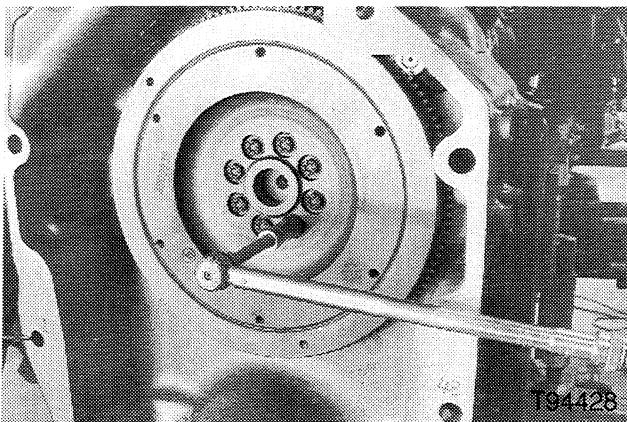

Remove the flywheel from the engine.

NOTE: The starter can remain attached to the flywheel housing. Make sure that the engine wiring harness is removed from the starter.

STEP 24

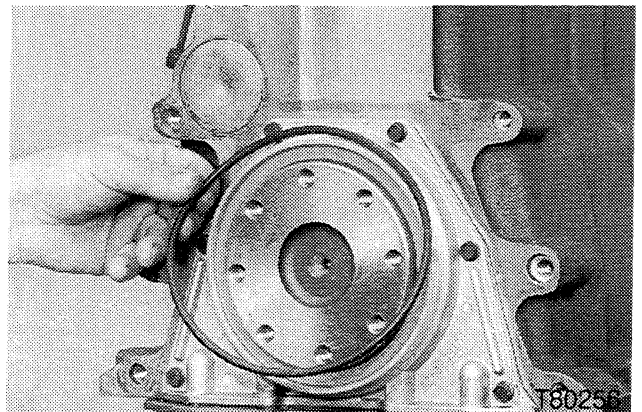

Remove and discard the o-ring from the engine rear seal carrier.

FLYWHEEL HOUSING INSTALLATION

STEP 25

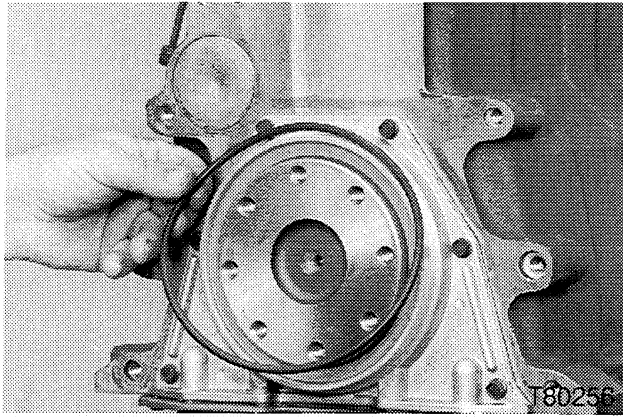

Lubricate a new o-ring with petroleum jelly and install the o-ring on the engine seal carrier.

STEP 27

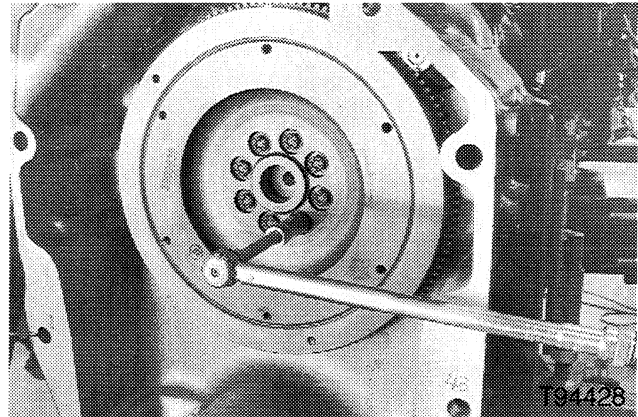

Install the flywheel on the crankshaft. Tighten the mounting bolts to a torque of 137 Nm.

STEP 26

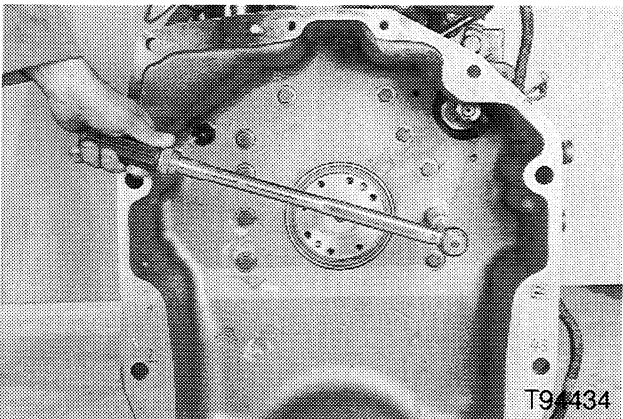

Install the flywheel housing and tighten the bolts to a torque of 60 Nm.

STEP 28

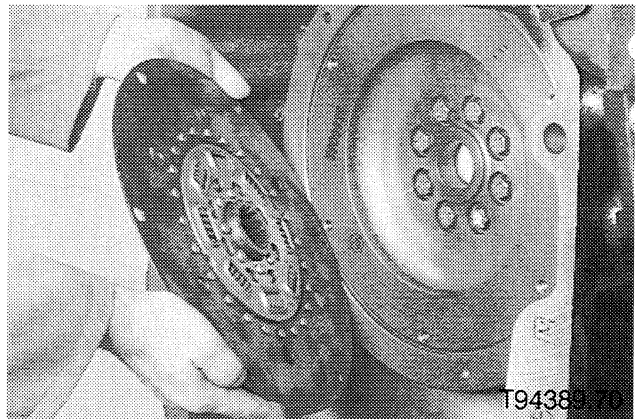

Install the flex plate on the flywheel. The side marked FLYWHEEL SIDE goes toward the flywheel.

Install the flex plate mounting bolts and washers and tighten to a torque of 94 to 106 Nm.

ENGINE INSTALLATION

STEP 29

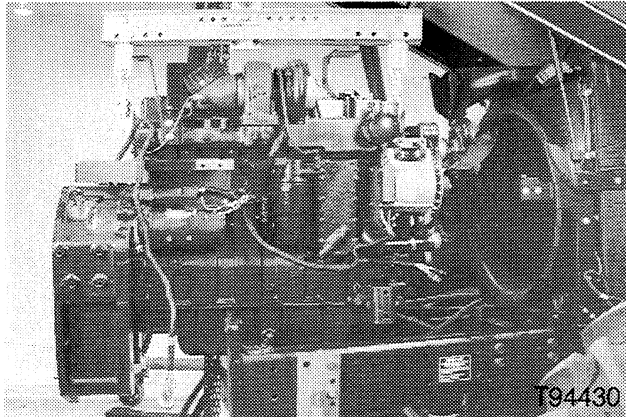

Support the engine with a sling and hoist attached to the front and rear lifting brackets. Move the engine into position next to the RH side frame.

STEP 30

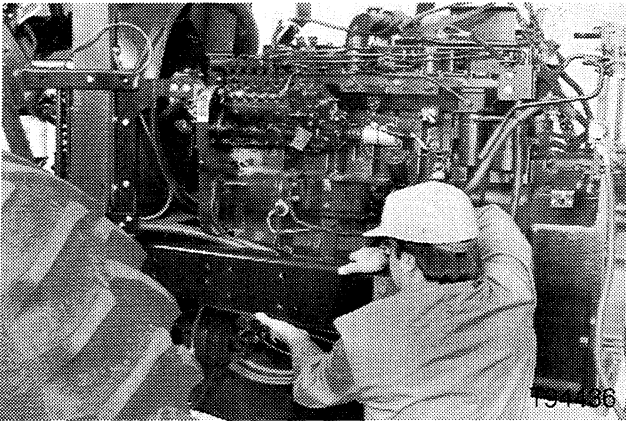

Install the side frames.

Tighten the side frame to flywheel housing M20 x 70 mm bolts to a torque of 425 to 485 Nm and the M22-2.5 x 70 bolts to a torque of 585 to 655 Nm.

Tighten the side frame to engine bolts to a torque of 94 to 106 Nm.

Tighten the side frame to bolster bolts to a torque of 220 to 250 Nm.

STEP 31

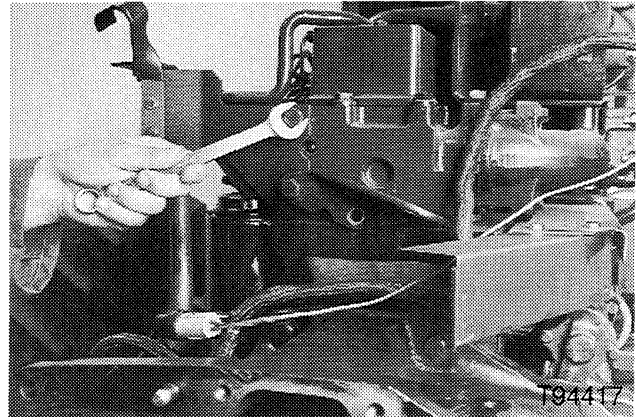

Remove the lifting sling and hoist from the engine. Move the engine lifting bracket to a horizontal position and install the mounting bolt through the side panel latch and into the engine.

STEP 32

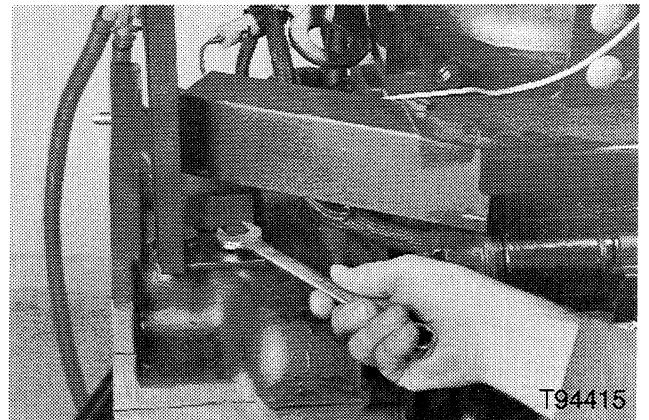

Install the hood support on the flywheel housing.

STEP 33

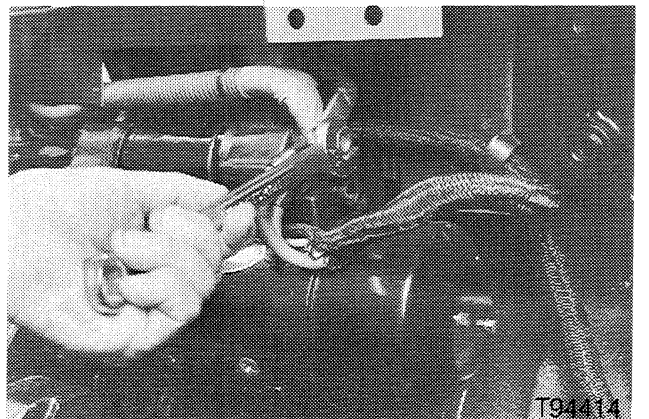

Install the battery cables on the starter.

NOTE: Make sure that the cables do not touch the sharp edges of the shield.

STEP 34

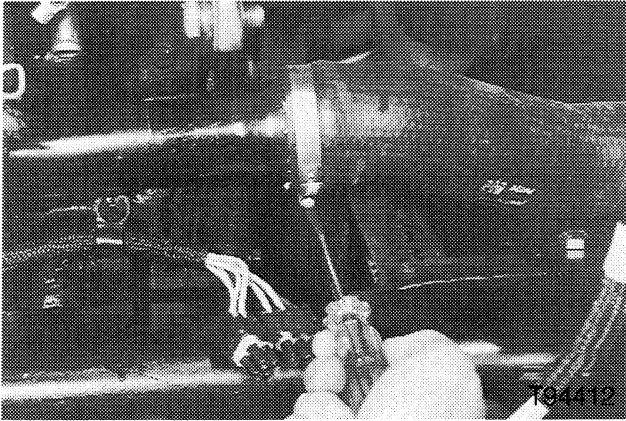

Install the radiator hoses.

STEP 35

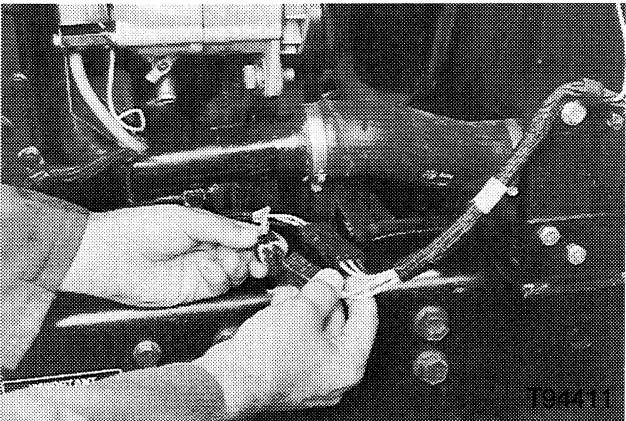

Connect the engine wiring harness to the front wiring harness.

STEP 36

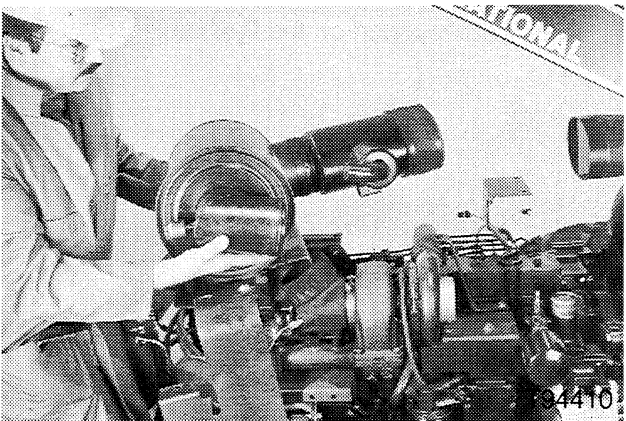

Install the air cleaner and strata tube in position on the engine. Tighten the bolts to a torque of 46 to 52 Nm.

STEP 37

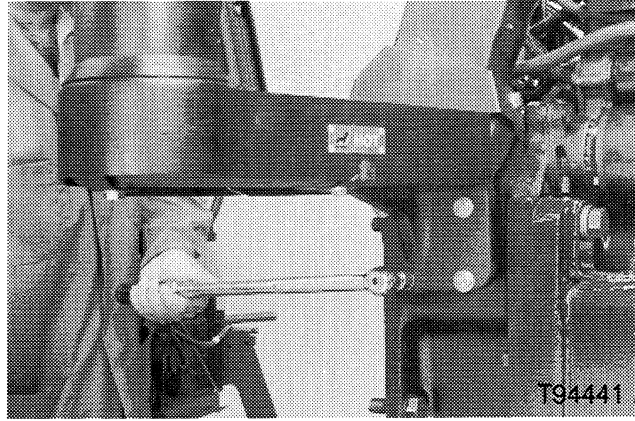

Install the exhaust elbow on the flywheel housing. Tighten the mounting bolts to a torque of 90 Nm.

STEP 38

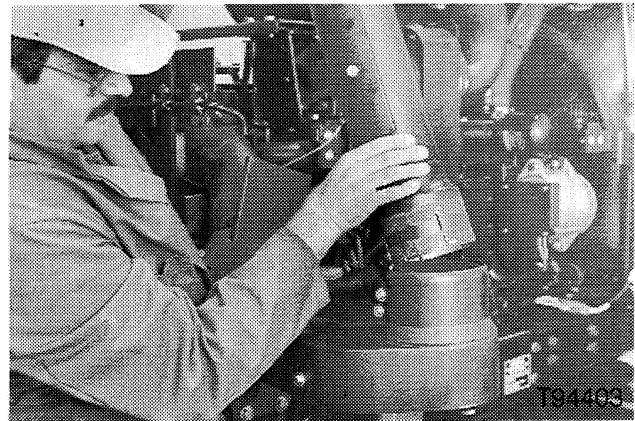

Install the exhaust pipe on the exhaust elbow. Tighten the seal clamp bolts to a torque of 46 to 52 Nm.

STEP 39

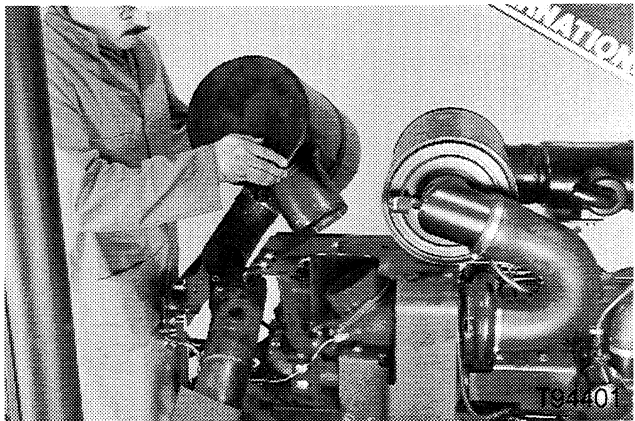

Install the muffler on the turbocharger exhaust elbow and the aspirator discharge pipe. Tighten the bolts to a torque of 46 to 52 Nm.

STEP 40

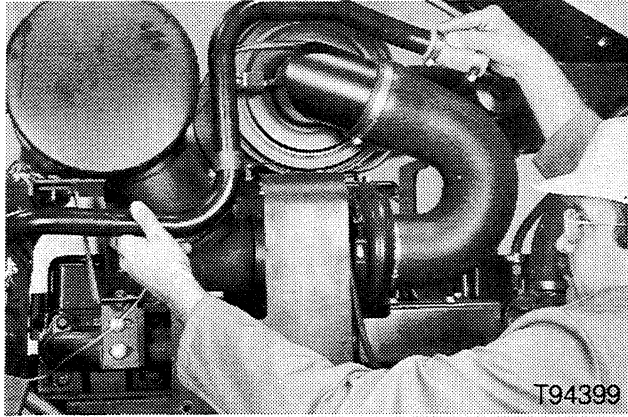

Install the aspirator tube between the strata tube and the aspirator discharge pipe.

STEP 43

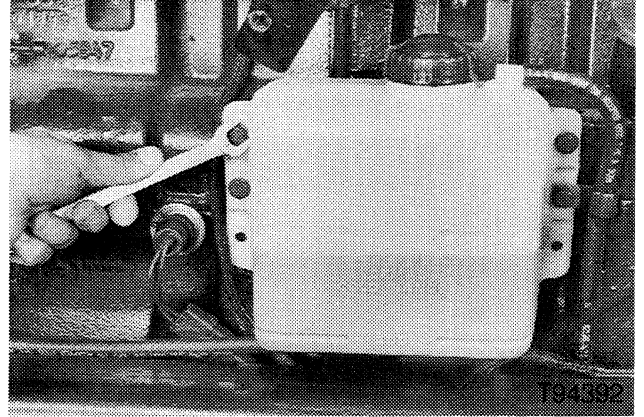

Install the radiator reservoir bottle on the brackets on the LH side of the engine.

STEP 41

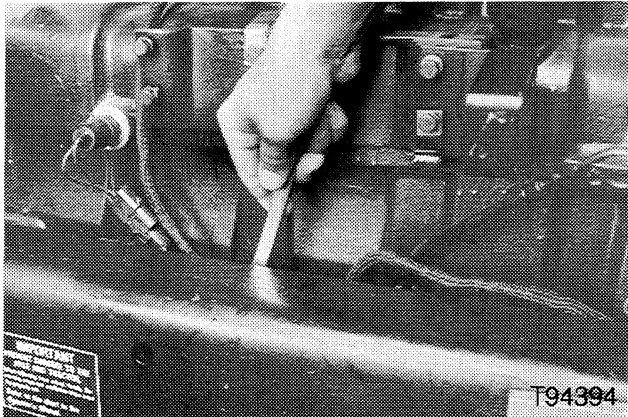

Install the wiring harness clamp on the inside of the LH side frame.

STEP 44

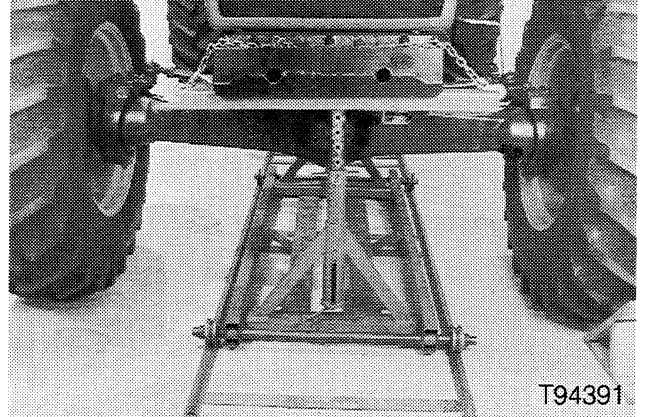

Remove the support from under the front weight carrier.

STEP 42

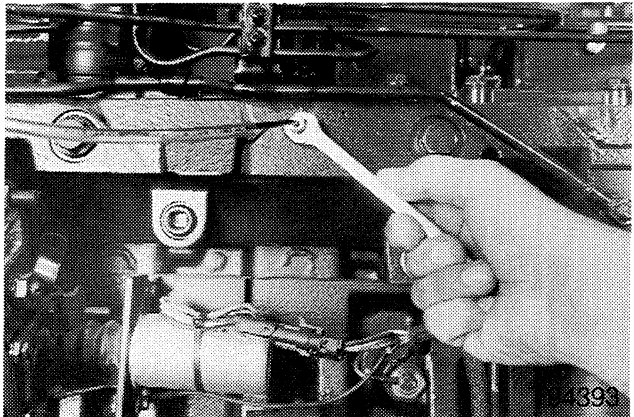

Install the ether start hose on the fitting in the intake manifold.

STEP 45

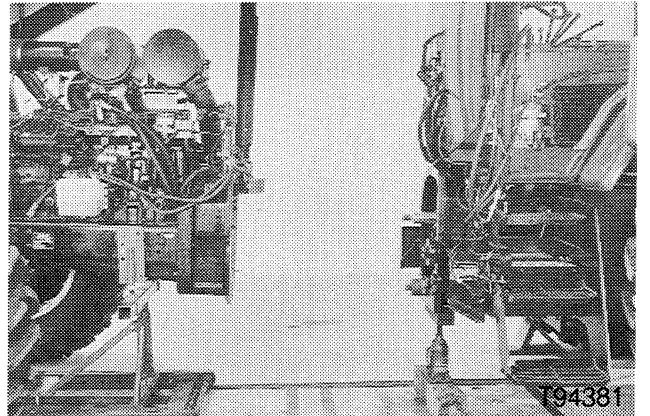

See Section 2004 in this manual to assemble the flywheel housing to the transmission speed housing.

STEP 46

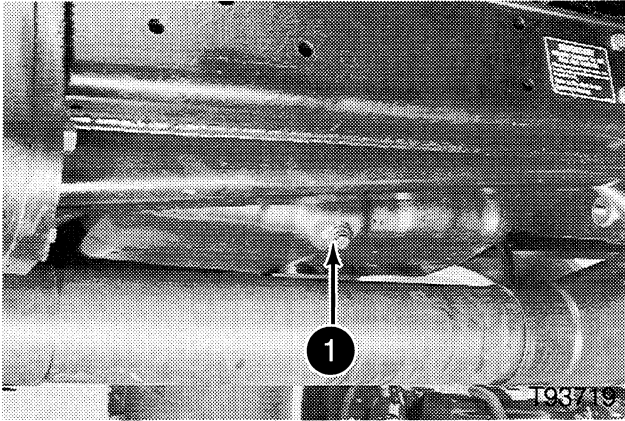

1. Drain Plug

Install the drain plug in the engine oil pan. See the Lubrication Section in the operators manual and fill the engine with the correct type and quantity of oil.

STEP 47

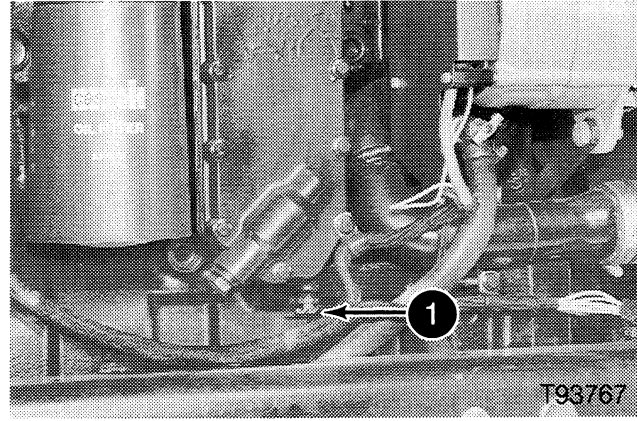

1. Block Drain Valve

Close the engine block drain valve. See Section 2004 in this manual and follow the air removal and filling procedure given for the cooling system.

NOTE: The CASE CORPORATION reserves the right to make improvements in design or changes in specifications at any time without incurring any obligation to install them on units previously sold.

DISASSEMBLY

STEP 1

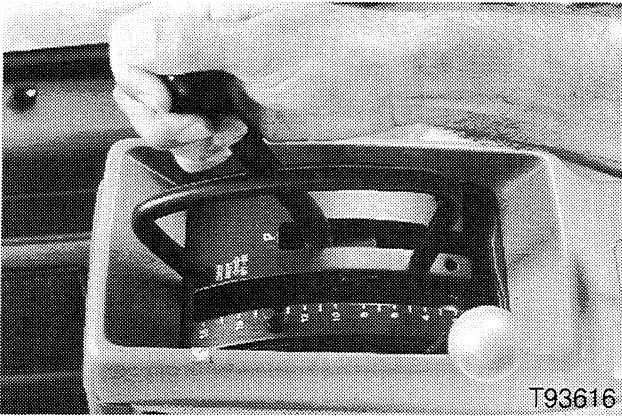

Put the gear shift control lever in the PARK position.

STEP 4

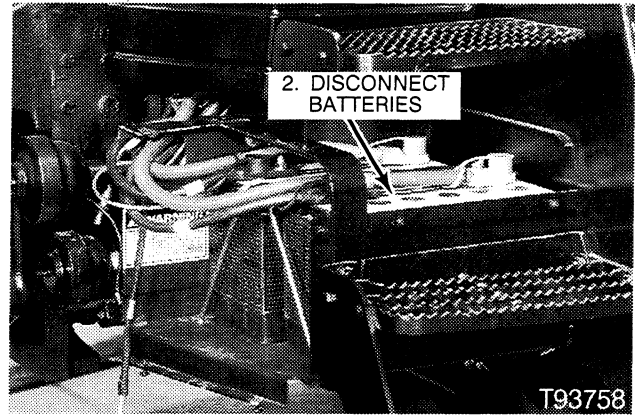

Remove the battery covers and disconnect the battery cables.

NOTE: Always remove the negative battery cables first.

STEP 2

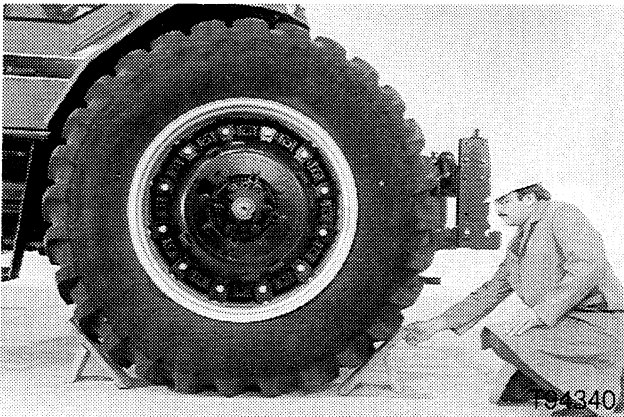

Put blocks in front of and behind the tractor tires.

STEP 5 MFD ONLY

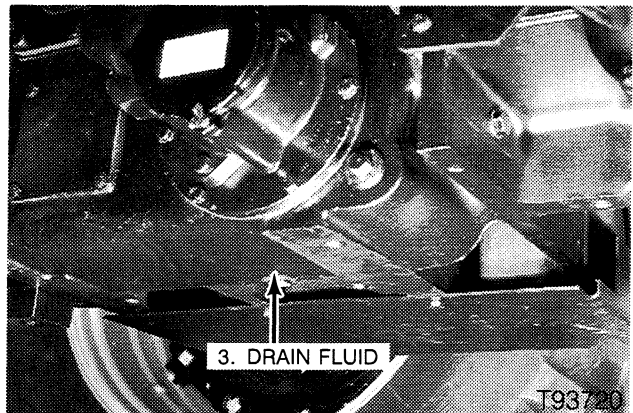

Put a container under the transmission housing. Remove the drain plug and drain the transmission fluid.

STEP 3

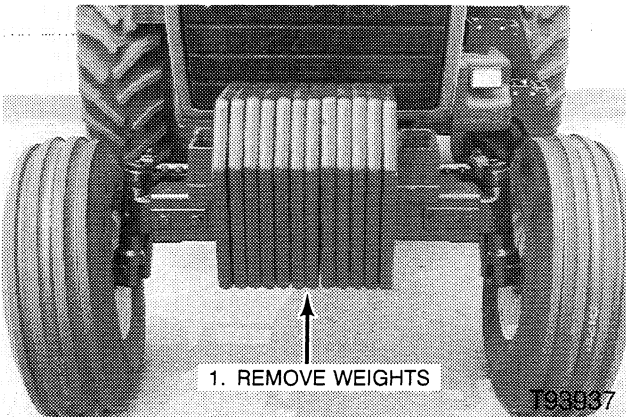

Remove the front weights from the tractor weight frame.

STEP 6

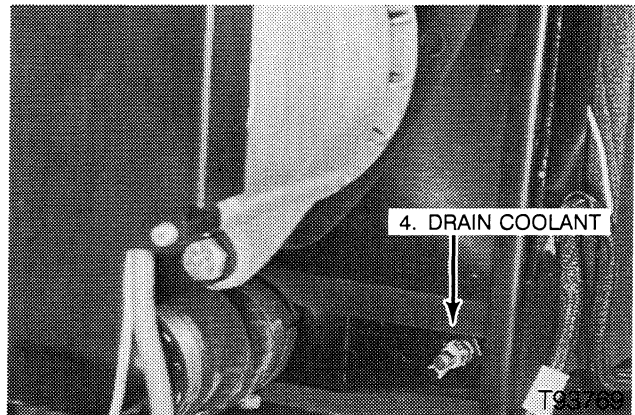

Drain coolant from the engine and radiator.

DISCONNECTS ON LH SIDE OF TRACTOR

STEP 7

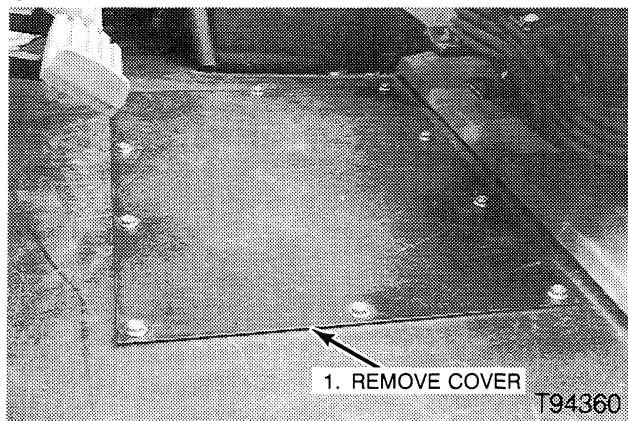

Remove the cab floor mat and remove the access cover from the cab floor.

STEP 8 INCREASED FLOW HYDRAULICS

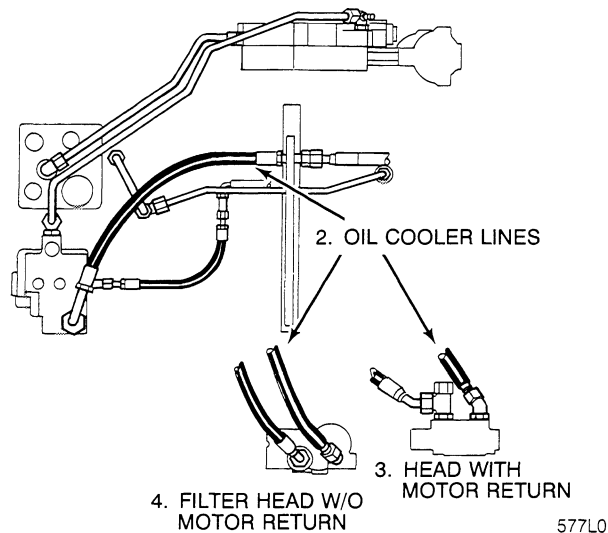

Disconnect the oil cooler lines.

STEP 9 STANDARD FLOW HYDRAULICS

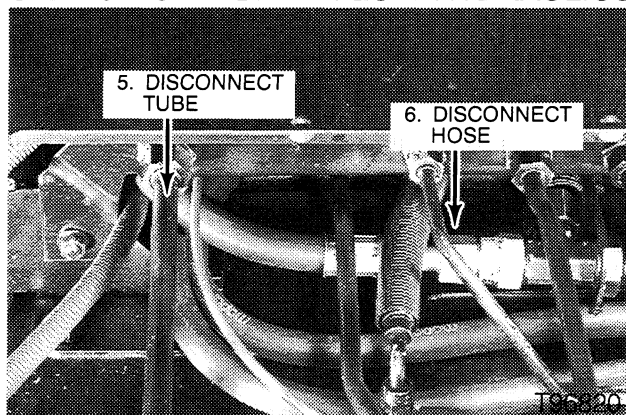

Disconnect the oil cooler lines.

STEP 10

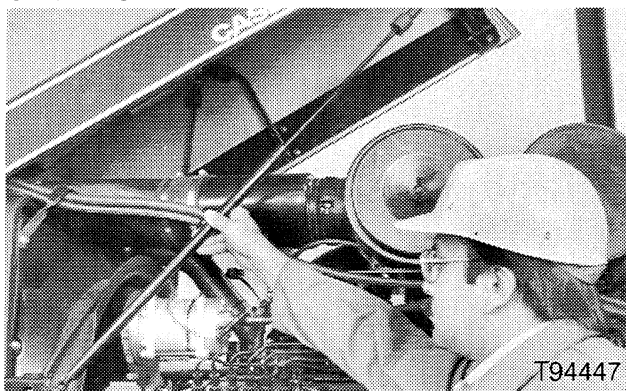

Remove the retaining wire from each end of the LH hood strut and remove the hood strut from the tractor. Make sure that the hood hinge lock is engaged.

Support hood when disconnecting cylinders, as hood will partially come down.

SM139

STEP 11

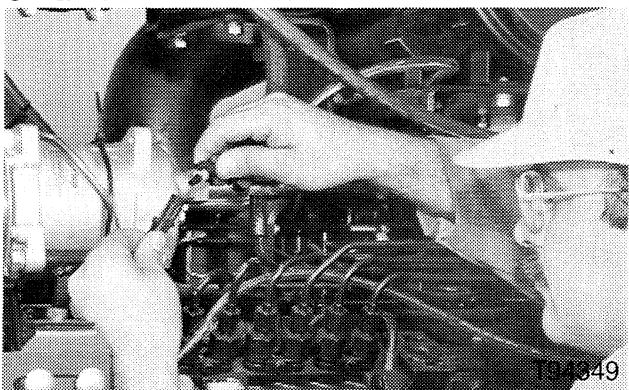

Disconnect the air conditioning compressor wiring harness.

STEP 12

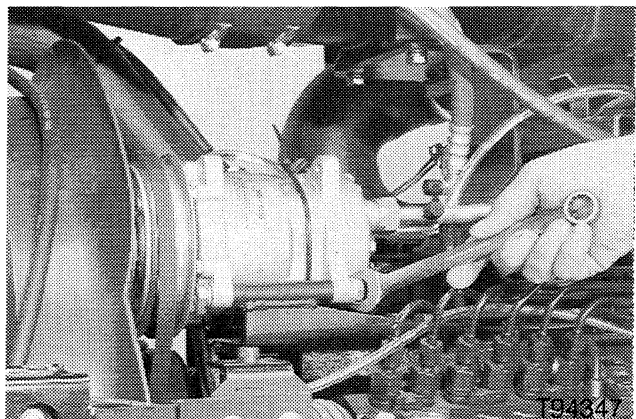

Remove the air conditioning compressor and drive belt. Do not disconnect the lines from the compressor.

STEP 13



Remove the condensor. Do not disconnect the lines from the condensor.

STEP 14

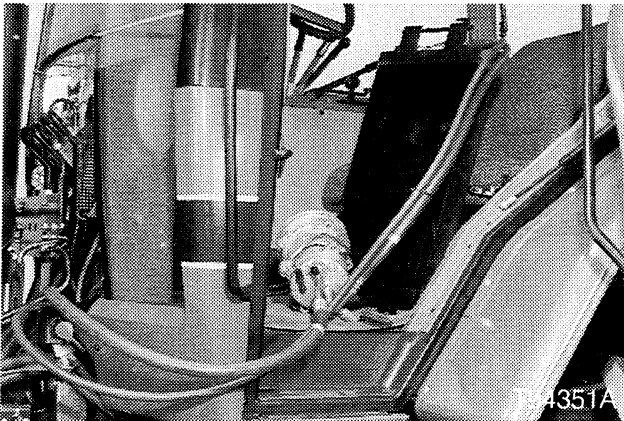

Carefully put the air conditioning compressor and condensor, with the hoses still attached, in the tractor cab.

STEP 15

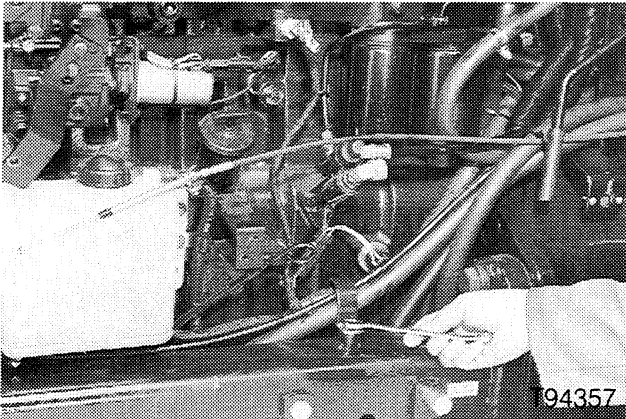

Remove the hose retaining clamp from the LH side frame.

STEP 16 AUXILIARY FUEL TANK

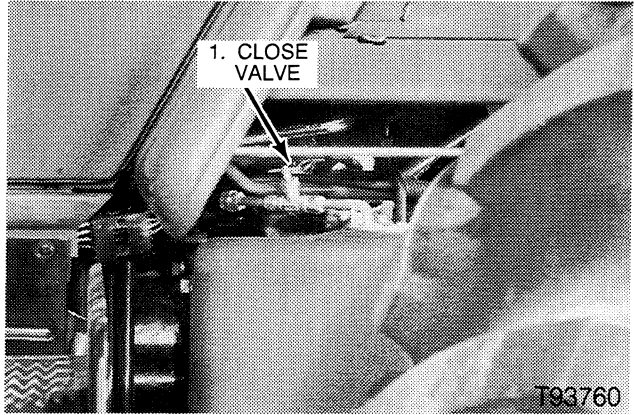

MAIN FUEL TANK

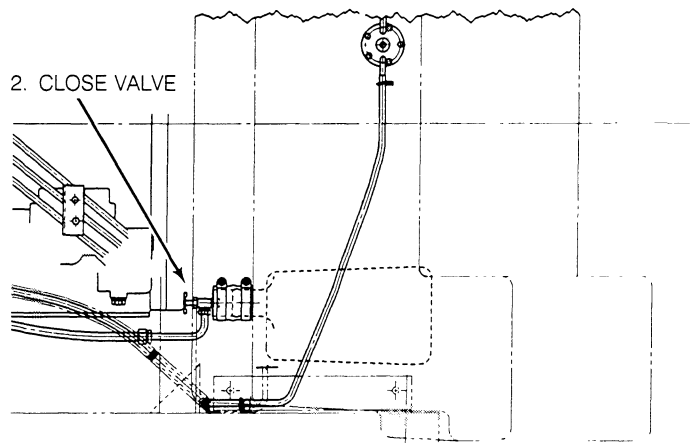

Close the fuel shut off valve on top of the auxiliary tank (if equipped). Close the fuel shut off valve on the lower LH corner of the main tank (if equipped).

STEP 17

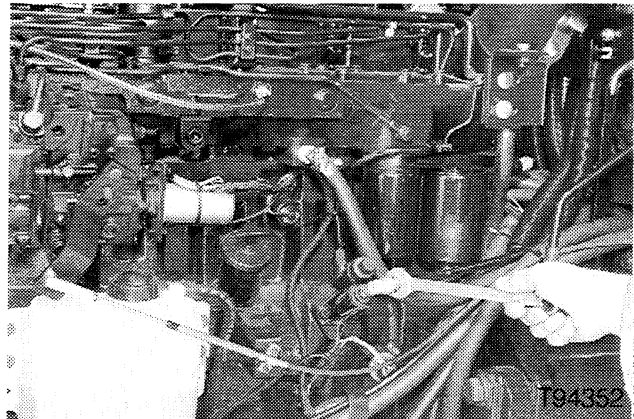

Disconnect the fuel supply hose from the engine primer pump.



Suggest:

If the above button click is invalid.

Please download this document

first, and then click the above link

to download the complete manual.

Thank you so much for reading

STEP 18

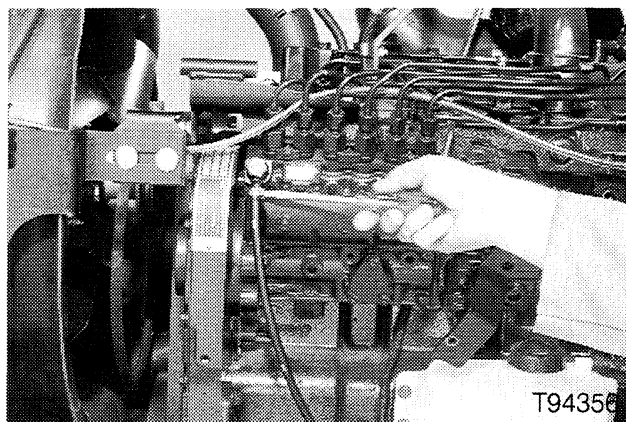

Disconnect the fuel return hose from the fuel injection pump.

STEP 19

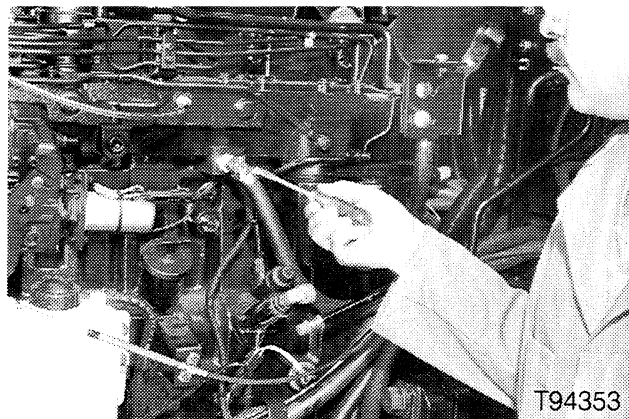

Disconnect the heater hose from the shut off valve on the LH side of the engine.

STEP 20

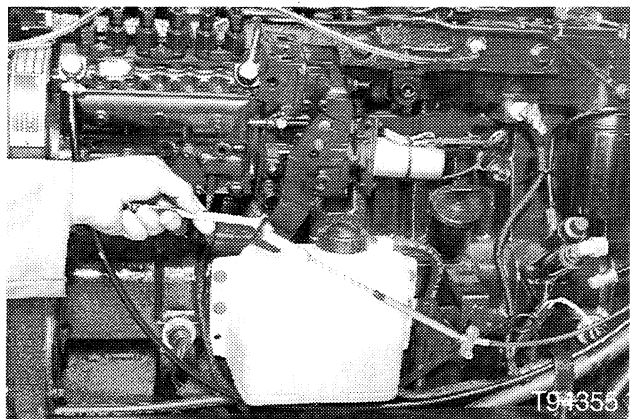

Remove the throttle cable or cables (if equipped) from the injection pump and from the cable mounting bracket.

STEP 21

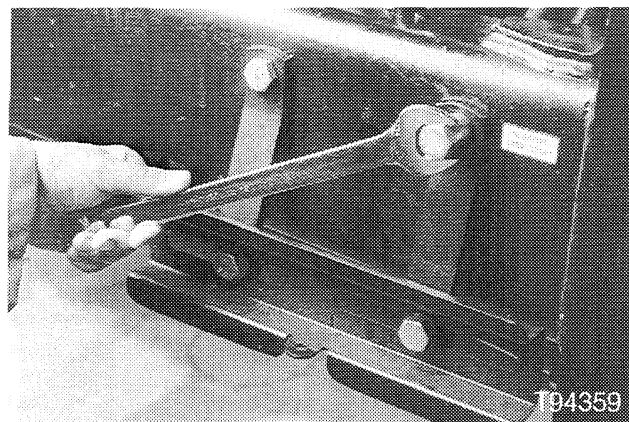

Remove the tool box mounting bracket from the LH side frame.

STEP 22

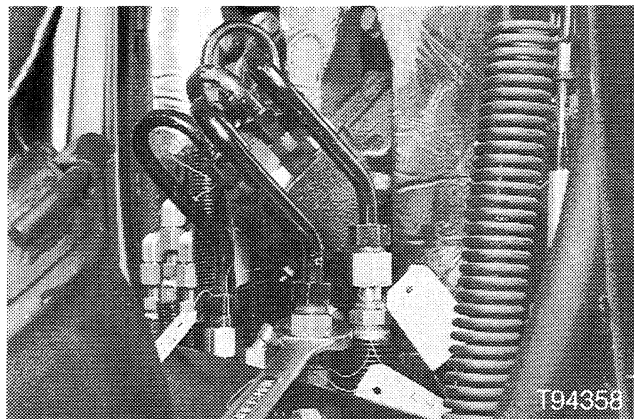

Mark the steering tubes on the LH side of the steering hand pump with their location and remove the hoses.

STEP 23

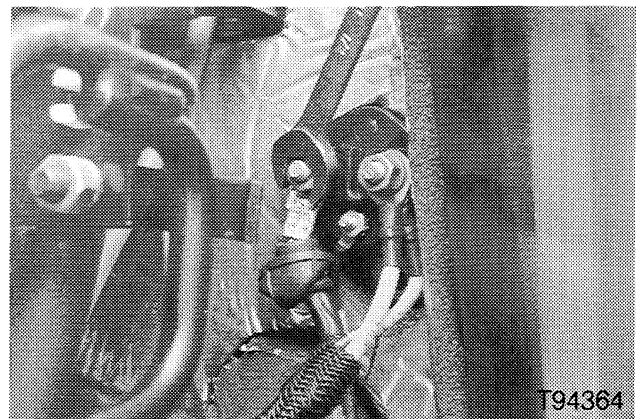

Disconnect the wires from the starter solenoid on the firewall.

<https://www.ebooklibonline.com>

Hello dear friend!

Thank you very much for reading.

Enter the link into your browser.

The full manual is available for immediate download.

<https://www.ebooklibonline.com>