

TABLE OF CONTENTS

4994 TRACTOR

SERIES	SECTION	DESCRIPTION	FORM NUMBER
10		GENERAL	
	1210	General Specifications	8-25750
	1215	Lubrication	8-25760
	1220	Engine Specifications - 14 Litre	8-25620
	1230	Fuel System Specifications	8-25630
	1260	Power Train Specifications	8-25900
	1270	Brake System Specifications	8-25910
20		ENGINE	
	2201	Troubleshooting - Engine	8-25670
	2202	Engine Tune-Up	8-24980
	2210	Engine Removal	8-25740
	2215	Cylinder Heads, Valves and Rocker Arms	8-24990
	2220	Cylinder Block, Sleeves, Pistons and Rods	8-25000
	2225	Crankshaft and Main Bearings	8-25010
	2230	Camshaft, Bushings and Valve Lifters	8-25020
	2240	Flywheel and Rear Oil Seal	8-25030
	2245	Lubrication System - Pump, Oil Cleaner and Heat Exchanger	8-25040
	2255	Cooling System	8-25050
	2265	Turbocharger	8-25060
	2275	Air Induction and Exhaust System	8-25070
	2565	Turbocharger - Failure Analysis	9-78235
30		FUEL SYSTEM	
	3210	Fuel System and Filters	8-25080
	3212	Fuel Injection Pump	8-25090
	3213	Fuel Injectors	8-25100
	3240	Electric Fuel Pump	8-25460
40		ELECTRICAL	
	4201	Electrical System Troubleshooting	8-25590
	4205	Instrument Cluster Troubleshooting	8-25280
	4210	Tractor Electrical Wiring Diagram	8-25250
	4214	Electrical Troubleshooting 12 Speed Power Shift Transmission	8-25270
	4220	Cab Electrical Wiring Diagram	8-25260
	4225	Steering Wiring Diagram	8-25290
	4230	Starting Motor	8-25680
	4235	Battery Servicing and Testing	8-20291
	4240	Alternator	8-25690
50		STEERING	
	5201	Troubleshooting and Adjusting the Steering System	8-25640
	5210	Steering Column, Pump and Valve	8-25480
	5220	Steering Cylinder	8-25490
	5240	Rear Steering System Valves	8-25430
	5250	Front Steering Priority Valve	8-25470
	5270	Rear Steering Oil Filters	8-25450

Reprinted

SERIES	SECTION	DESCRIPTION	FORM NUMBER
60		POWER TRAIN	
	6210	Transmission Removal	8-25810
	6240	Power Shift Transmission	8-24560
	6245	Hydraulic PTO	8-25330
	6250	Axles and Planetaries	8-25160
6260	Differentials and Drive Shifts	8-25170	
70		BRAKES	
	7210	Service and Parking Brake	8-25530
	7220	Brake Pedal and Master Cylinder	8-25360
80		HYDRAULICS	
	8210	Hydraulic Oil Filters	8-25440
	8220	Hydraulic Charge Pump	8-25320
	8225	Hydraulic Pump	8-25210
	8250	Remote Hydraulic Valves	8-25370
	8260	Transmission Flow Divider Valve	8-25400
8265	Hydraulic System Pressure Inducer Valve	8-25410	
90		CHASSIS and ACCESSORIES	
	9205	Troubleshooting Air Conditioning System	8-25650
	9215	Gauge and Testing Air Conditioning System	8-25660
	9225	Compressor Isolation, Charging and Discharging A/C System	8-25700
	9235	Servicing Air Conditioner Components	8-25710
	9245	Servicing the Cab Blower	8-25580
	9250	Operators Seat	8-25510
	9260	Hood Removal and Alignment	8-25420
	9265	Hood Lifting Hand Pump	8-25500
	9270	Cab Removal	8-25800
9290	Safety Decal Location	8-25570	
100		HOW IT WORKS	
14205	Digital Instrument Cluster	8-25110	

Section 1210

GENERAL SPECIFICATIONS

Written In *Clear
And
Simple
English*

<https://www.ebooklibonline.com>

Hello dear friend!

Thank you very much for reading.

Enter the link into your browser.

The full manual is available for immediate download.

<https://www.ebooklibonline.com>

SERIAL NUMBERS

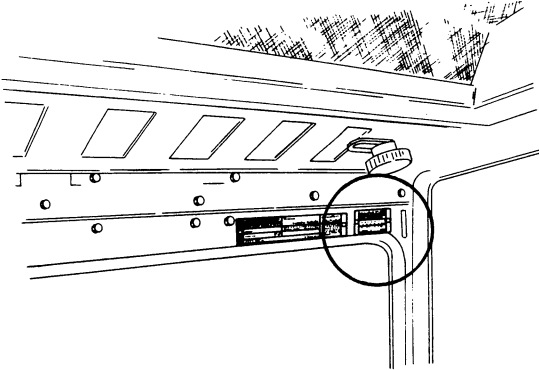

MODEL AND PRODUCT IDENTIFICATION NUMBER PLATE

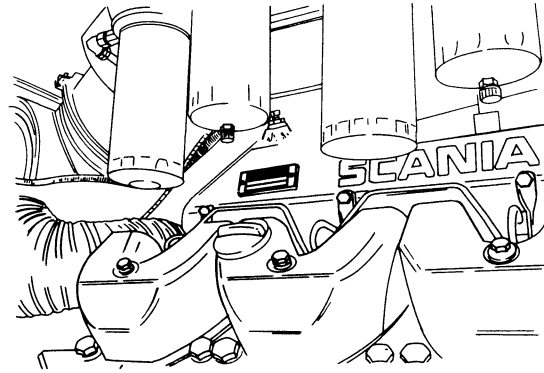

ENGINE SERIAL NUMBER PLATE

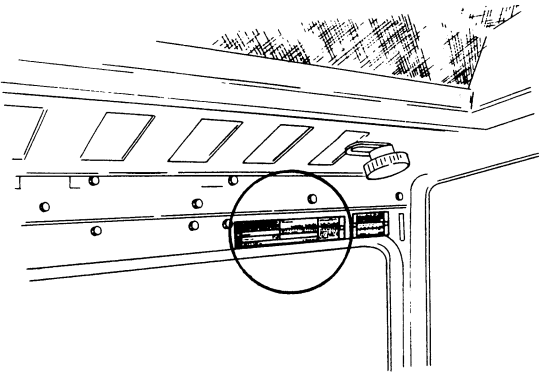

CAB SERIAL NUMBER PLATE

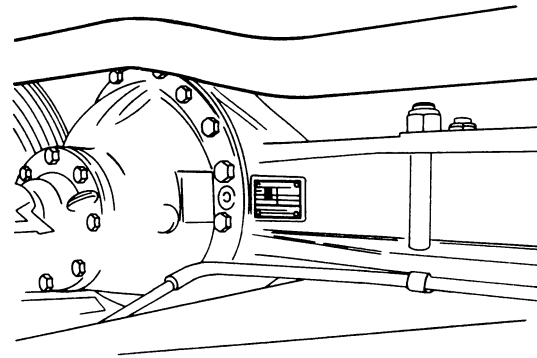

AXLE SERIAL NUMBER PLATE (Front and Rear)

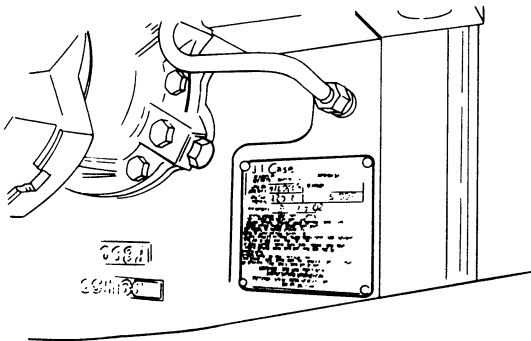

TRANSMISSION SERIAL NUMBER PLATE

DIESEL ENGINE SPECIFICATIONS

General

Type	Eight Cylinder, Four Stroke Cycle, Turbocharged, Valve in Cylinder Head
Firing Order	1-5-4-2-6-3-7-8
Bore	5 Inches (127 mm)
Stroke	5.51 Inches (145 mm)
Piston Displacement	866 Cubic Inches (14 191 cm ³)
Compression Ratio	15.5 to 1
Cylinder Sleeves	Wet Type, Can be Removed
Governor Engine Speed Without Load	2300 to 2400 RPM
Rated Engine Speed	2100 RPM
Engine Idle Speed	750 RPM
Rocker Arm-to-Valve Clearance (Exhaust)	0.031 Inch (0.80 mm)
(Intake)	0.018 Inch (0.45 mm)

IMPORTANT: *Rocker Arm-to-Valve clearance adjustment must be made when the engine is not running.*

Piston and Rod

Rings Per Piston	3
Compression Rings Per Piston	2
Oil Rings Per Piston	1
Type Piston Pin	Full Float
Type Bearings	Replacement Bearings Available, Steel Back with Lead-Bronze liners.

Main Bearings

Number of Bearings	5
Type of Bearings	Replacement Bearings Available, Steel Back with Lead-Bronze Liners.

Engine Lubrication System

Oil Pressure	65 to 87 PSI (448 to 600 kPa)(4.5 to 6.0 bar) with Engine Warm and Operating at Rated Speed.
Type System	Pressure and Spray
Oil Pump	Gear Type
Oil Cleaning	Oil Cleaned Continuously by Separation in Centrifugal Type Oil Cleaner.
Oil Capacity	27 U.S. Quarts (25.5 litres)
Oil Cooler	Engine Oil Water Cooling
Turbocharger Oil Filter	Full Flow Turn On Type
Pistons	Gallery Cooled

Fuel System

Fuel Injection Pump	Robert Bosch, Multiple Plunger
Pump Timing	18 Degrees (BTC) Before Top Center.
Fuel Injectors	Robert Bosch, 21 mm.
Fuel Transport Pump	Plunger Type, a Part of the Fuel Injection Pump
Governor	Variable Speed, Part of the Fuel Injection Pump
Primary Fuel Filter (Two Per Tractor)	Full Flow, Turn on Type
Secondary Fuel Filter (Two Per Tractor)	Full Flow, Turn on Type
Water Trap and Drain For Fuel Tanks	Location is on the side at the Bottom of Each Fuel Tank
Fuel Tank Capacity	150 U.S. Gallons (568 litres) Each Tank, 300 U.S. Gallons (1136 Litres) Total
Fuel Level Gauge	LCD Bar Indicator, Location is on Instrument Cluster
Hand Primer Pump	Location is on the Injector Pump
Fuel Strainer	Location is on Front RH side of Engine
Electric Transfer Pump	Location is on RH Fuel Tank
Electric Primer Switch	Location is on Fuel Filter Bracket

GENERAL TRACTOR SPECIFICATIONS

Air Intake System

Type Dry Type Air Induction System, Two Stage with Service Monitor, Strata Tube.

Cooling System

Capacity 88 U.S. Quarts (83.3 litres)
 Type Pressure System, Thermostat Controlled, Bypass Centrifugal Type Pump
 Radiator Heavy Duty Fin and Tube Type
 Thermostats (2) Start to Open at Approximately 167°F (75 °C), Fully Open at 202°F (94°C)
 Pressure Cap 10 PSI (69 kPa)(6.9 bar) No Vent
 Coolant Level Water Level Service Monitor on Instrument Cluster
 Coolant Temperature LCD Bar Indicator on Instrument Cluster

Electrical System

Type of System 12 volt, Negative Ground
 Batteries Two 12 Volt Batteries Connected in Parallel, AABM Group Size 30H, Rated in 1.255 to 1.265 Specific Gravity. Discharge Rate 300 Amperes at 0°F.
 Alternator 12 Volt, 105 Ampere Output, Negative Ground
 Voltage Regulator 12 Volt, Solid State, Inside Component of Alternator
 Starting Motor 12 Volt with Solenoid Switch
 Head Lamps (2) 12 Volt, 40/60 Watt Sealed Beam High-Low
 Front Flood Lamps (4 Max.) 12 Volt, 50 Watt, Halogen Sealed Beam
 Rear Flood Lamps (6 Max.) 12 Volt, 50 Watt, Halogen Sealed Beam
 Flasher Lamps with Direction Turn Signals (2) 12 Volt, Amber Lens
 Tail Lamps (2) 12 Volt, Red Lens
 Electrical System Circuit Breakers
 Primary Circuit 12 Volt, Three 50 Ampere Circuit Breakers Connected in Parallel, 150 Ampere Rating, 112.5 Ampere Minimum Continuous Capacity.
 Auxiliary Circuit 12 Volt, Four 50 Ampere Circuit Breakers

Electrical System

Bulb and Lamp Replacement:

Instrument Cluster Lamps	No. 73
Dome Lamp Bulb	No. 93
Console Lamp Bulb	No. 194
Flasher Lamp Bulbs	No. 1156
Head Lamps	No. 4652
Front and Rear Flood Lamps	No. A48265
Tail Lamp Bulbs	No. 168

Fuse Replacement:

Instrumentation	3.0 Ampere
Shutdown Solenoid	25 Ampere
Tail Lamp	15 Ampere
Lamp Switch Feed	25 Ampere
Accessories	3.0 Ampere
Switch Controls	10 Ampere
Head Lamp Low Beam	15 Ampere
Head Lamp High Beam	15 Ampere
Front Flood Lamps	25 Ampere
Radio and Night Lamp	10 Ampere
Ignition Switch	15 Ampere
Flasher and Dome Lamp	15 Ampere
Rear Flood Lamps	25 Ampere
Wiper	7.5 Ampere
Blower	15 Ampere
Cigarette Lighter	15 Ampere
Transmission/Steering Controller	7.5 Ampere
Hitch Controller (If Equipped)	5.0 Ampere
Fuel Pump and Accessory Power Line	7.5 Ampere
Cluster	5.0 Ampere

Tractor Brakes

Type	Single Disc, Dual Caliper, Hydraulic Actuated, Self-Adjusting.
Fluid Type	SAE J1703 (DOT 3)

Parking Brake

Type	Cable Actuated by over center Type Handle Adjustable from Operators Seat.
------------	--

Power Shift Transmission

Type	Full Range Power Shift, Electrically Controlled, Hydraulically Actuated Clutches with a Modulated Inching Clutch
Speed Selection	12 Speeds Forward, 2 Speeds Reverse
Shift Control	Single Hand Lever on Instrument Panel Electrically Activates Micro-Processor
Oil Cooler	Transmission
Oil Type	Case Powergard PTF
Oil Refill Capacity (With PTO)	*63 U.S. Quarts (59.6 litres)
(Without PTO)	*59 U.S. Quarts (55.8 litres)

*Includes 8 Quarts (7.6 litres) For Filter Change.

Hydrostatic Front Power Steering

Oil Supply	Hydraulic Pump, 20 gpm (75.7 litres/min) at 2100 RPM at 2000 PSI (13 790 kPa)(138 bar).
Relief Valve Pressure	2500 PSI (17 237 kPa)(172 bar)
Front Steering Cylinders	Two Cylinders with two way action
Steering Pump	Hydrostatic Type, Actuated by the steering wheel

Rear Power Steering

Oil Supply	Hydraulic Pump, 20 gpm (75.7 litres/min) at 2100 RPM at 2000 PSI (13 790 kPa)
Relief Valve Pressure	2500 PSI (17 237 kPa) (172 bar)
Rear Steering Cylinders	Two Cylinders with Two Way Action
Controls	Selective Steering with Automatic rear Steering with all Wheels Controlled by steering wheel or rear wheels Controlled by a hydraulic-electric servo system with three position selection switch and a toggle switch on operator console.

Axle Differential and Planetaries

Front and Rear	Spiral Bevel with Planetary Reduction in hub.
Planetary Oil Capacity	13.5 Quarts (12.8 litres) Each Planetary
Differential Oil Capacity - Front	17 Quarts (16 litres)
Differential Oil Capacity - Rear	22.5 Quarts (21.3 litres)

Remote Hydraulic System

Pump	Axial Piston Pump, Pressure and Flow Compensated
Type Remote Valve	Closed Center, Two to Four Sections, Hand Lever Control, Variable Flow Control for Each Section.
Pump Capacity at 2100 RPM	35 GPM (132.5 litres/min) at 2000 PSI (13 790 kPa)(137.9 bar).
Max System Pressure	2650 PSI (18 271 kPa)(182.7 bar)
Couplings	ASAE S366 Standard (Will Also Fit ISO Male Couplers), Fast Removal, Break Away Type
Hydraulic Charge Pump	35 GPM (132.5 litres/min) at 2100 RPM and 100 PSI (240 kPa)(2.4 bar).
Charge Circuit Relief Valve Pressure	35 PSI (241 kPa)(2.41 bar)
Oil Type	Case TCH
Oil Capacity	105 Quarts (99.4 litres)

Power Takeoff

Type Clutch	Hydraulic Actuated
Rotation	Clockwise
Spline Size	20 Splines, 1-3/4 inch (44.5 mm) Diameter
Engine Speed 2100 RPM	1000 RPM Shaft Speed

Drawbar

Standard or Yoke Type	Full Swing, Roller Mount, Takes a 2 inch (50.8 mm) Diameter Pin
-----------------------------	--

APPROXIMATE TRACTOR SPEEDS IN MPH AND KM/H AT 2100 RPM 12 Speed Power Shift Transmission

NOTE: This tractor is made to work constantly at the rated horsepower when the tractor speed is 5 MPH (8 km/h) and faster.

SPEED RANGE	TIRE SIZE									
	30.5 X 32		24.5 X 32		23.1 X 34		20.8 X 38		20.8 X 42	
	MPH	KM/H	MPH	KM/H	MPH	KM/H	MPH	KM/H	MPH	KM/H
1	2.5	4.0	2.5	4.0	2.5	4.0	2.6	4.2	2.7	4.3
2	3.0	4.8	3.0	4.8	3.0	4.8	3.1	5.0	3.3	5.3
3	3.6	5.8	3.6	5.8	3.5	5.6	3.7	6.0	3.9	6.3
4	4.3	6.9	4.3	6.9	4.3	6.9	4.4	7.1	4.7	7.6
5	5.2	8.4	5.1	8.2	5.1	8.2	5.3	8.5	5.6	9.0
6	6.1	9.8	6.1	9.8	6.1	9.8	6.3	10.1	6.7	10.8
7	7.2	11.6	7.2	11.6	7.1	11.4	7.4	11.9	7.9	12.7
8	8.6	13.8	8.6	13.8	8.6	13.8	8.9	14.3	9.4	15.1
9	10.2	16.4	10.1	16.3	10.1	16.3	10.5	16.9	11.1	17.9
10	12.3	19.8	12.2	19.6	12.1	19.5	12.6	20.3	13.4	21.6
11	14.8	23.8	14.7	23.6	14.6	23.5	15.2	24.5	16.1	25.9
12	17.5	28.2	17.4	28.0	17.3	27.8	17.9	28.8	19.1	30.7
REVERSE 1	3.2	5.1	3.2	5.1	3.1	5.0	3.3	5.3	3.5	5.6
REVERSE 2	5.4	8.7	5.4	8.7	5.4	8.7	5.6	9.0	5.9	9.5



CAUTION: Radial ply tires are much more flexible than bias ply tires. At higher speeds, the sideward flexing of radial tires can cause steering control difficulty. This problem is more severe with: (1) heavy loads carried on the three point hitch; and (2) single wheel installations as compared to dual wheel installations.

During transport, keep speed slow enough to maintain steering control.

APPROXIMATE MEASUREMENTS

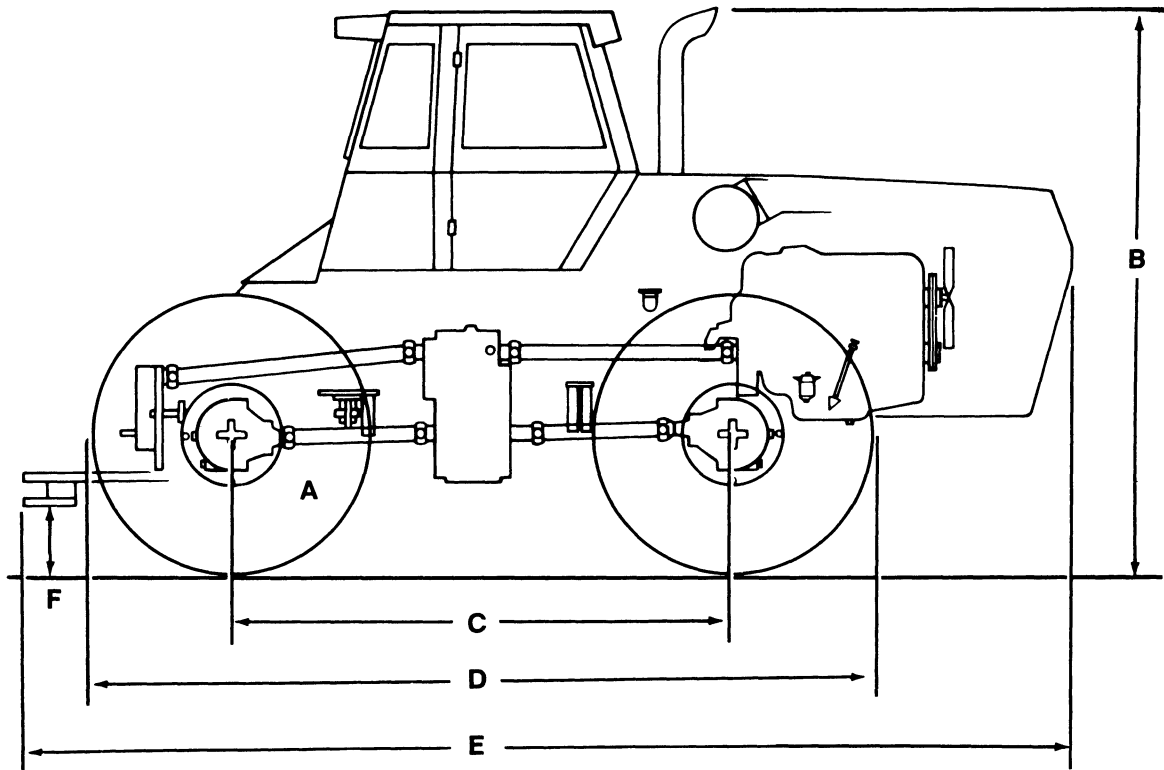

A	TIRE 23.1-34 RI	C	124.8 Inches (3 170 mm)	E	261.8 Inches (6 650 mm)
B	138.5 Inches (3 518 mm)	D	195.9 Inches (4 976 mm)	F	14.5 Inches (368.3 mm)

Over All Width 120 Inches (3 048 mm)
 Turning Radius (Minimum) With 91 Inch (2 312 mm) Wheel Tread 212.2 Inches (5 390 mm)
 Rear Axle Oscillation (15 Degrees from Level) 30 Degrees Total

APPROXIMATE TRANSPORT WEIGHT

Approximate Tractor Weight Front 15,900 lbs (7 212 kg)
 With 23.1-34 Tires, PTO and Full Fuel Rear 10,600 lbs (4 808 kg)
 Total 26,500 lbs (12 020 kg)

IMPORTANT: *The total tractor weight with ballast and weights must never be more than 40,000 lbs (18 150 kg).*

OPERATORS CAB

THIS CASE OPERATORS CAB HAS ROLL OVER PROTECTION AS GIVEN IN ASAE STANDARDS S336.1 and S383, SAE STANDARDS J168a and J1194 AND OSHA REGULATIONS 1928.51 and 1928.53.

Section

2202

ENGINE TUNE-UP

866 Cubic Inch Diesel Engines

Written In *Clear
And
Simple
English*

Adjusting Rocker Arm To Valve Clearance

STEP 1

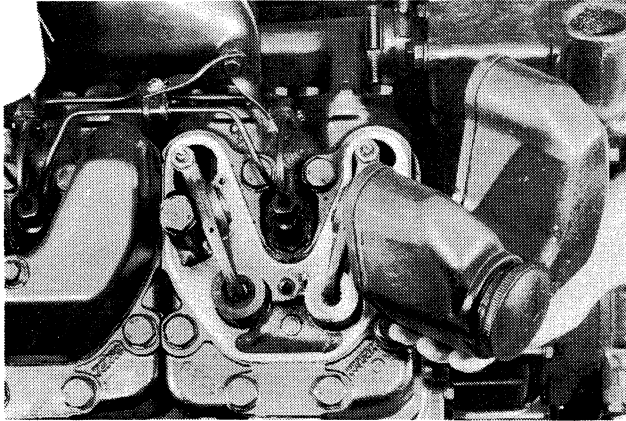

Remove the valve covers from the cylinder heads on both sides of the engine.

STEP 2

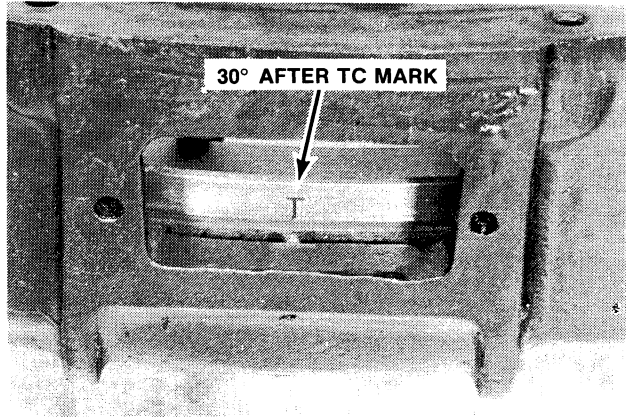
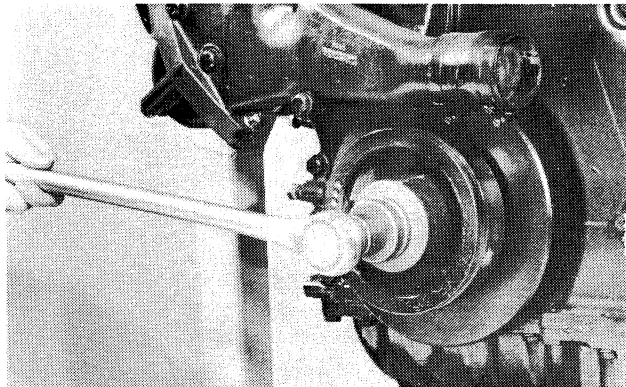

Turn the engine over clockwise until the 30° after TC mark on the flywheel aligns with the timing pointer.

STEP 3

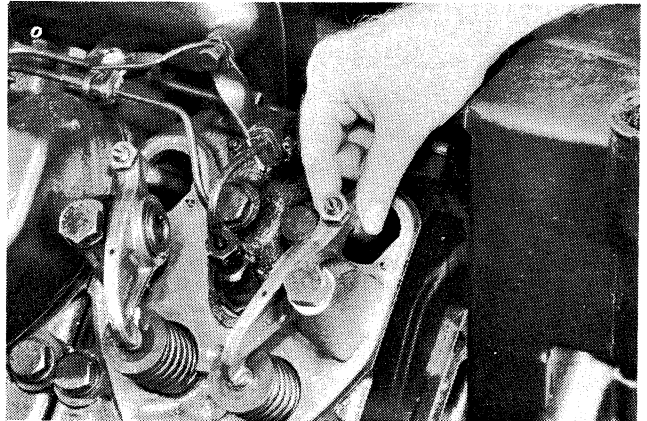

Check the push rods on the No. 1 cylinder for looseness. If the push rods are tight, turn the engine over one revolution.

STEP 4

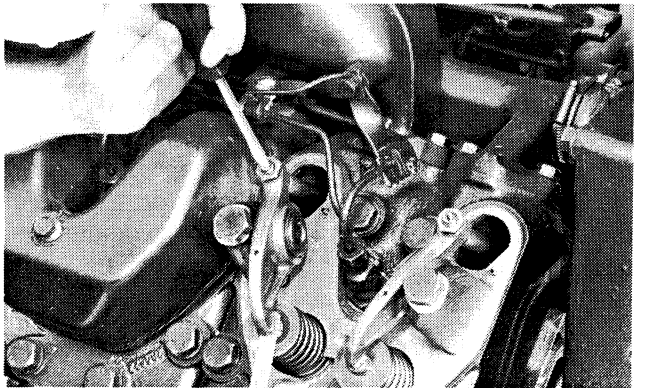

Check and adjust the intake and exhaust valves as shown by the arrows below.

Valve clearance - Intake Valves 0.018 inch (0.45 mm) Exhaust Valves 0.031 inch (0.80 mm)

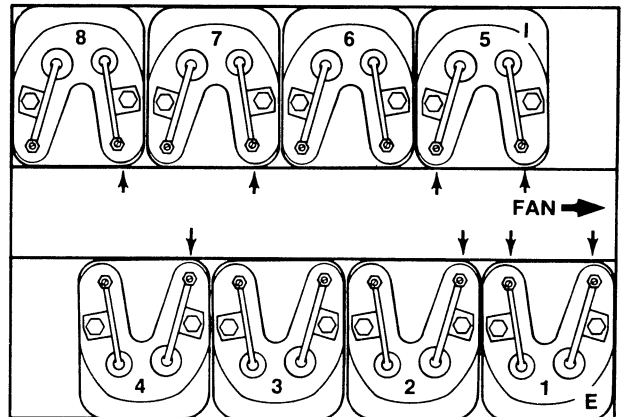

NUMBER ONE CYLINDER 30° AFTER TC COMBUSTION STROKE

STEP 5

Turn the engine over clockwise, one complete revolution and align the 30° after TC mark on the flywheel with the timing pointer.

Check and adjust the intake and exhaust valves as shown by the arrows below.

Valve clearance - Intake Valves 0.018 inch (0.45 mm) Exhaust Valves 0.031 inch (0.80 mm)

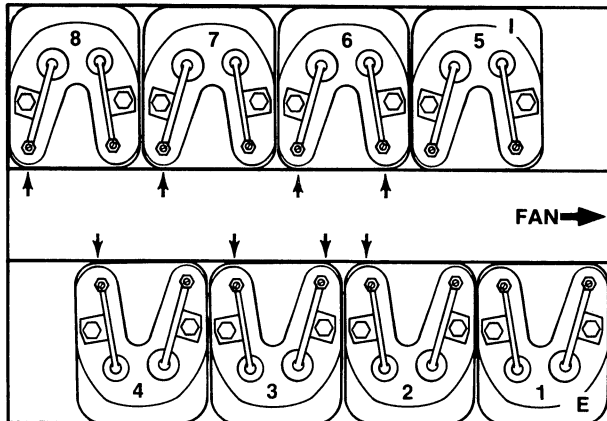

NUMBER ONE CYLINDER 30° AFTER TC
INTAKE STROKE

IMPORTANT: Valve clearance adjustments must be made when the engine is not running and the engine has to cool down a minimum of 1/2 hour after shutoff. Tighten the lock nuts on the valve clearance adjusting screws to an approximate torque of 30 lb ft (40 Nm)(4.0 kgm).

Checking Fuel Injector Nozzles

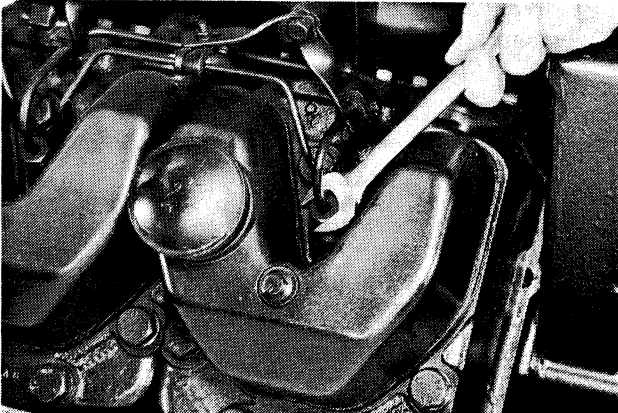
STEP 7

Disconnect the fuel supply and return lines from the injectors.

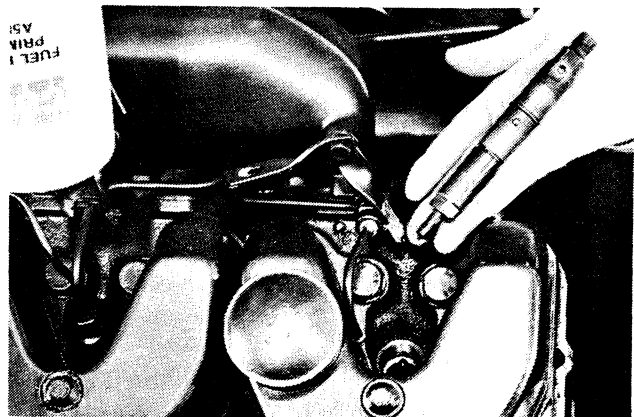
STEP 8

Remove and test each fuel injector. See Section 3213 in this Service Manual for removal and testing.

NOTE: Make a compression test on each cylinder before installing the injectors.

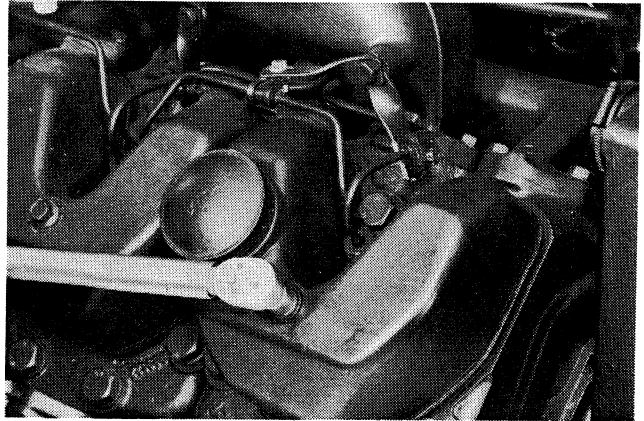
STEP 6

Install the valve cover for each cylinder head on the engine. Tighten the valve cover bolts to a torque of 124 lb in (14 Nm)(1.4 kgm).

Checking Engine Compression

STEP 9

There are two methods of checking the compression pressure. The two methods are the crank method and the engine running method. The engine must be at operating temperature for either method used.

1. CRANK METHOD - Remove all of the fuel injectors.
2. RUNNING METHOD - Disconnect the fuel supply and return lines from the Number One injector. Send the fuel from the lines back to the fuel tank or into a clean container. Repeat for each cylinder.



CAUTION Before cranking engine, make sure all operating controls are in neutral, brakes are set and wheels are securely blocked.

STEP 10

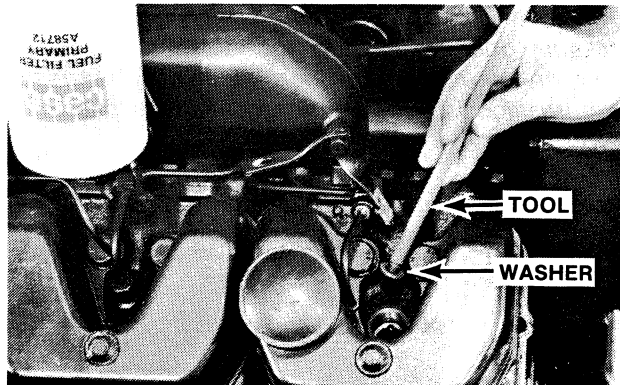

Use the injector washer extractor to remove the washer from the bottom of the injector bore. See the Special Tools To Be Made page.

STEP 11

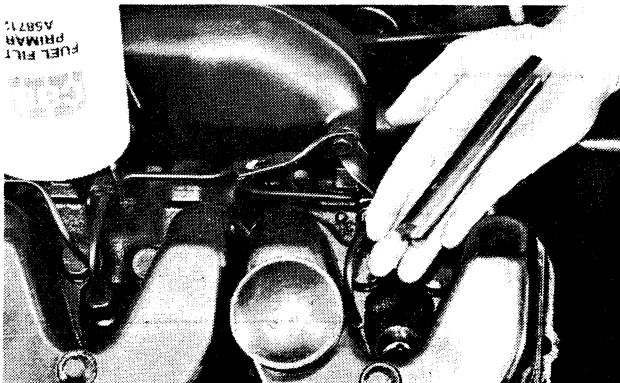

Use an injection bore carbon reamer to clean the injector bores in the cylinder heads. See the Special Tools page.

STEP 12

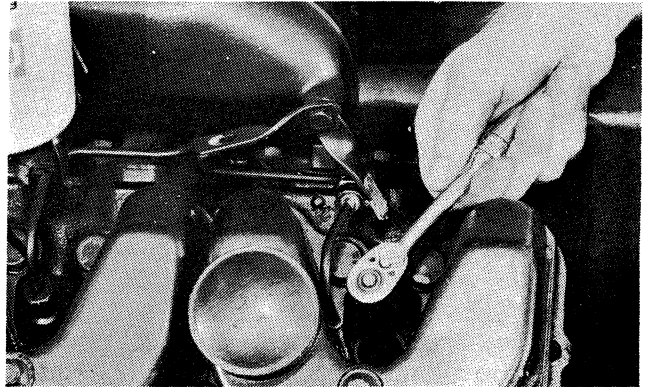

Always turn the tool clockwise. Turning the tool counterclockwise will damage the tool. After using the tool, clean the injector bores with compressed air.

STEP 13

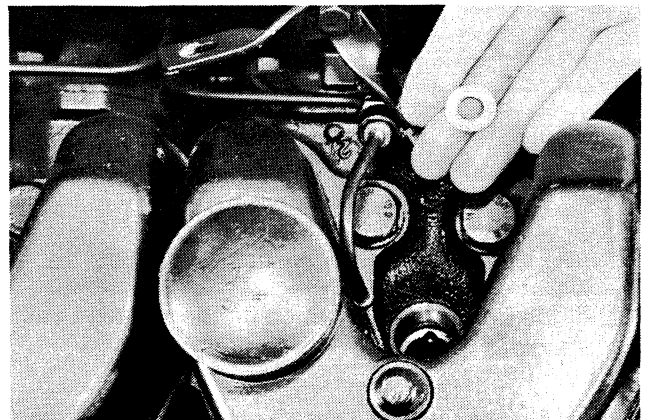

Install a new injector washer in the bore of the cylinder head.

STEP 14

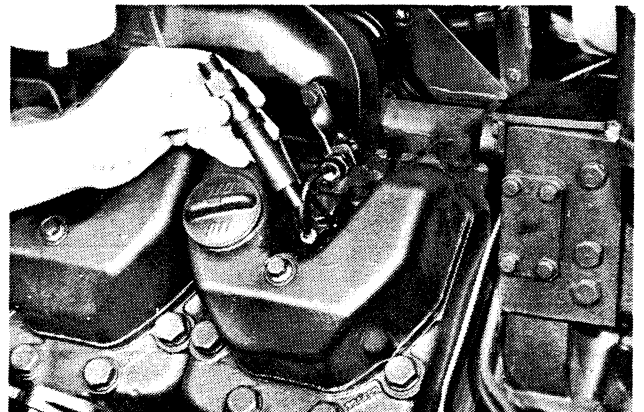

Install the compression gauge adapter in the cylinder head bore.

STEP 15

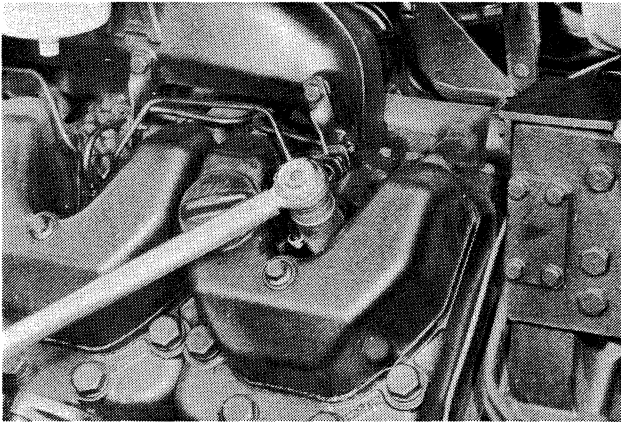

Tighten the compression gauge adapter in the injector bore to a torque of 52 lb ft (70 Nm)(7.0 kgm).

STEP 16

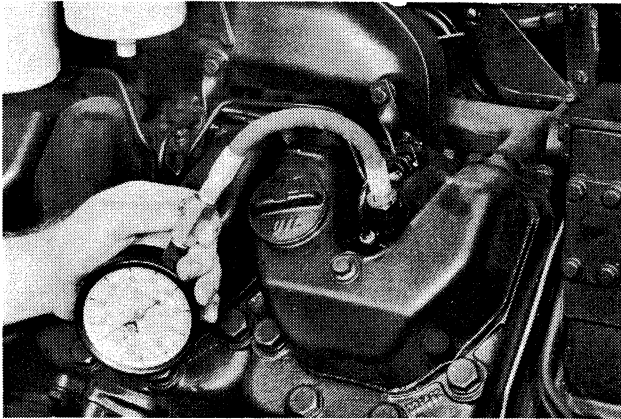

Install the compression gauge on the adapter. See the Special Tools page.

STEP 17

NOTE: Take several compression readings on each cylinder using the bottom on the compression gauge to decrease gauge pressure. See the chart below for correct compression pressure.

When checking the compression, using the crank method, start at the Number one cylinder and continue with the remainder of the cylinders in order (Number 2, 3, 4, etc.). Then check again the Number one cylinder after finishing the last cylinder, since compression can change because of a weak battery.

It is very important that all cylinder pressures be approximately the same. See the chart for permitted compression pressure differences.

More than normal compression is an indication of carbon deposits. Below normal compression is an indication of a valve that leaks or too much ring clearance.

NOTE: To make an easy test when the compression is below normal on one or more cylinders, put about 1/4 fl oz (7 ml) of clean engine oil in the cylinder and check the compression again. If the pressure goes up to near normal, then the compression loss is past the rings. Very little change in compression is an indication of leakage past the valves.

Remove the compression gauge, gauge adapter and injector washer from the cylinder head.

	ENGINE SPEED	NORMAL COMPRESSION PRESSURE	PERMITTED CHANGE BETWEEN CYLINDERS
CRANK METHOD	APPROXIMATELY 200 RPM UNTIL COMPRESSION GAUGE BECOMES CONSTANT	400 PSI * (2 758 kPa)(27.58 bar)	25 PSI (172 kPa)(1.72 bar)
RUNNING METHOD	800 RPM	480 PSI * (3 310 kPa)(33.10 bar)	20 PSI (138 kPa)(1.38 bar)

***NOTE:** A 4% reduction in PSI must be permitted for every 1000 ft (305 m) above sea level.

STEP 18

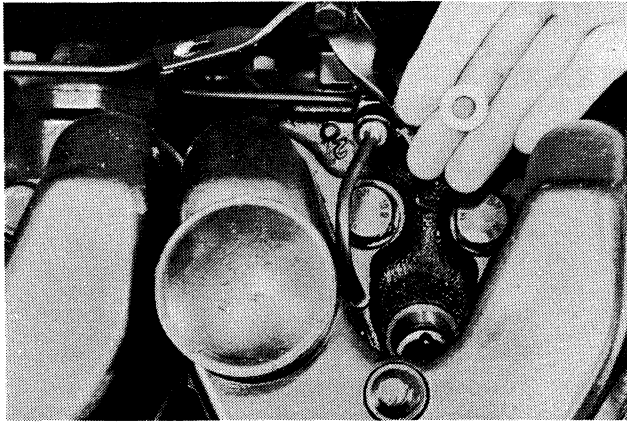

Install a new injector washer in each cylinder head bore.

STEP 19

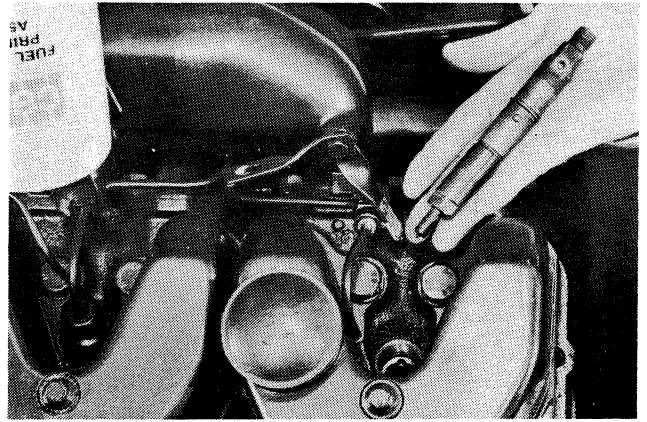

Install the fuel injectors. See Section 3213 in this Service Manual for installation.

Cleaning And Servicing The Air Intake System

STEP 20

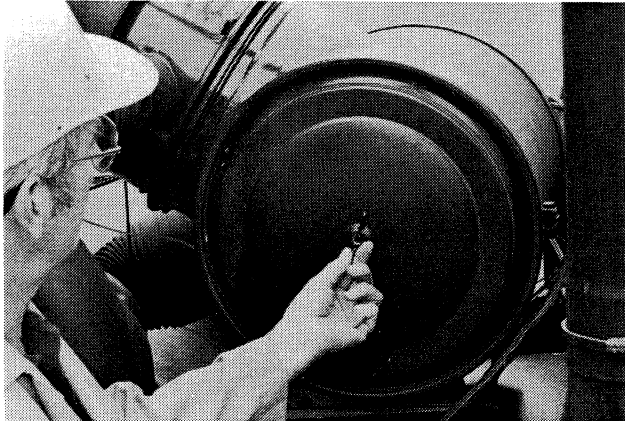

See Section 2275 in this Service Manual for cleaning and servicing the air intake system.

Timing The Fuel Injection Pump

STEP 22

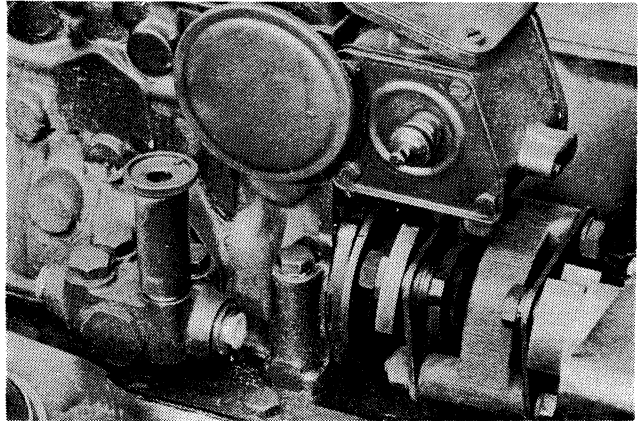

See Section 3212 in this Service Manual for checking and adjusting the timing of the fuel pump.

Servicing The Fuel Filters

STEP 21

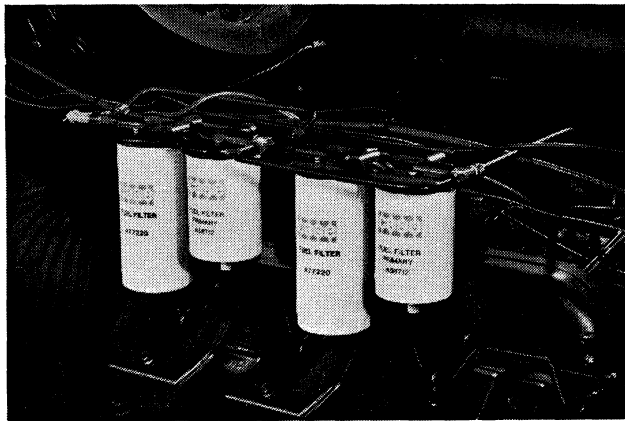

See Section 3210 in this Service Manual for servicing the fuel filters.

Checking Fuel Injection Pump Governed Speed

STEP 23

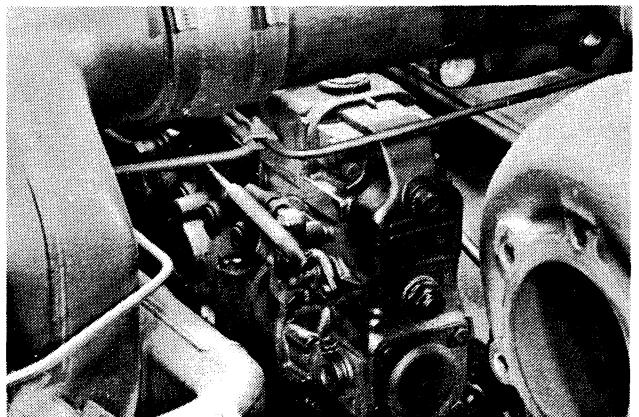

See Section 3212 in this Service Manual for checking the low idle governed speed of the fuel injection pump.

Adjusting Fan And Compressor Belts

STEP 24

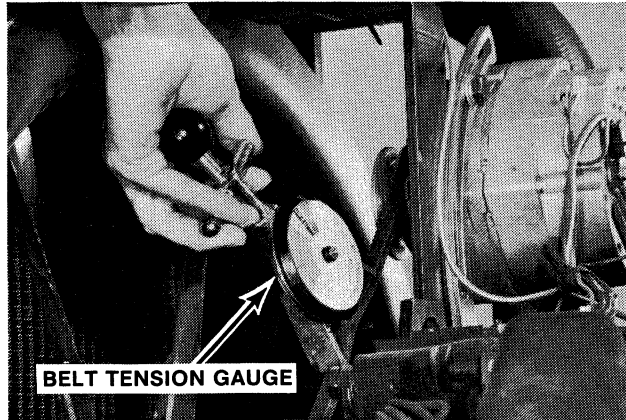

Use a belt tension gauge to measure the fan belt for the correct tension. Belt tension must be 80 lb (356 N).

STEP 25

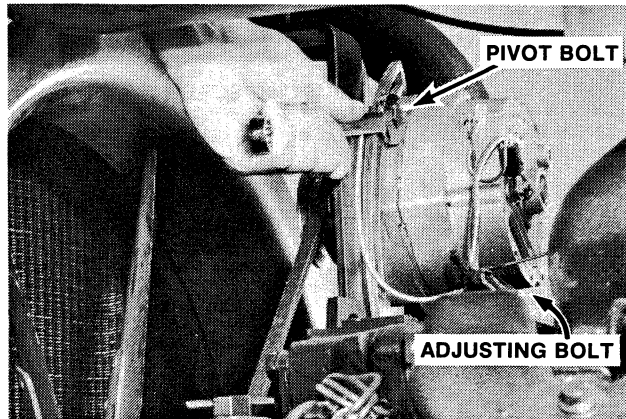

To adjust the belt, loosen the adjusting and pivot bolts. Pull the alternator out from the engine until the correct tension is reached. Pull only on the front casting of the alternator. Tighten the adjusting and pivot bolts.

STEP 26

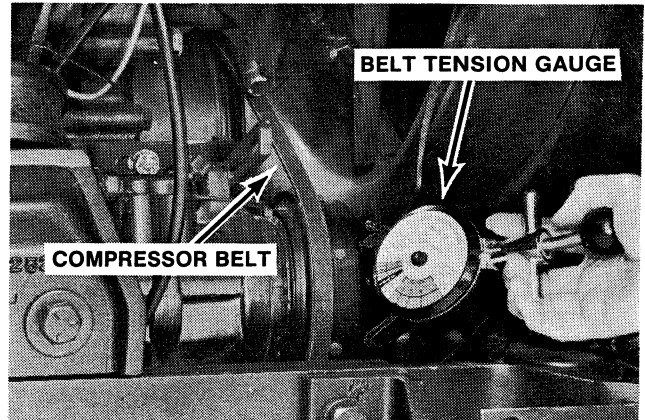

Use a belt tension gauge to measure the compressor belt for the correct tension. Belt tension must be 80 lb (356 N).

NOTE: See Section 9235 in this Service Manual for tension and alignment adjustments.

Checking Valve Timing

NOTE: This procedure can also be used to check for the correct assembly of the camshaft to the crankshaft gear teeth without removing the front timing gear cover.

STEP 27

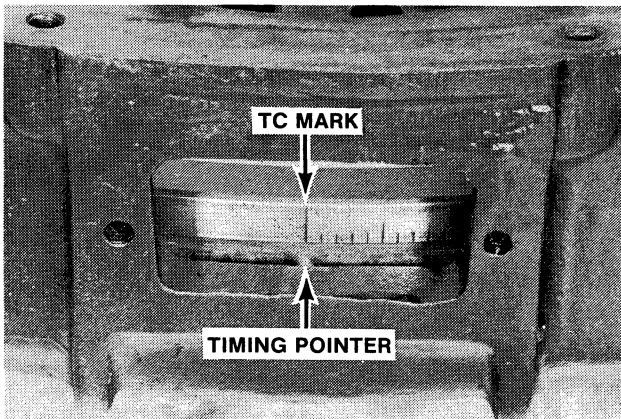
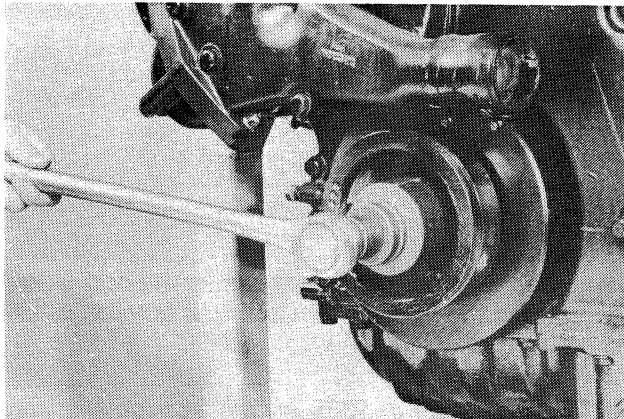

Turn the engine over clockwise until the 0° or TC mark on the flywheel aligns with the timing pointer.

STEP 28

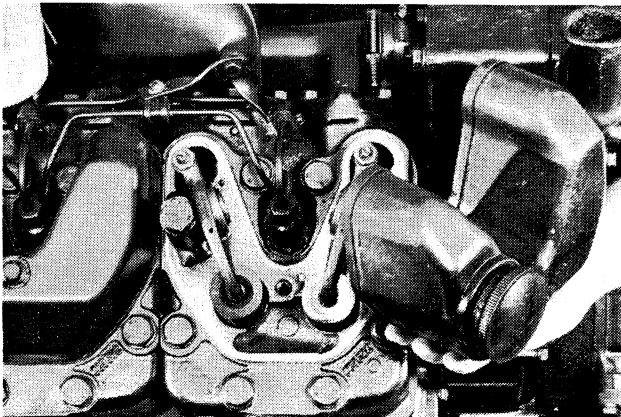

Remove the valve cover for the No. 1 cylinder head on the RH front side of the engine.

STEP 29

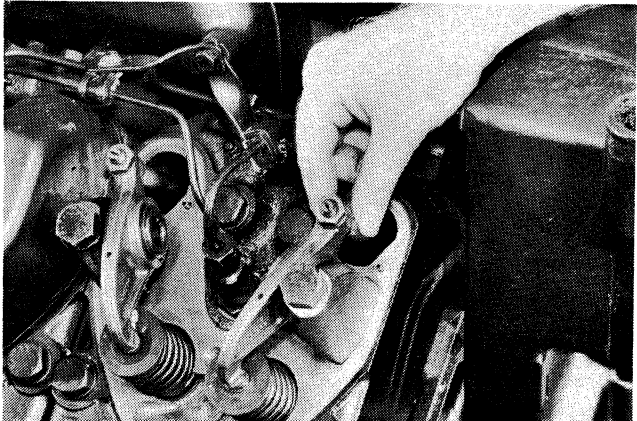

Check the No. 1 cylinder intake and exhaust valve push rods, the push rods must be loose. If the push rods are tight, turn the engine over one complete revolution.

STEP 30

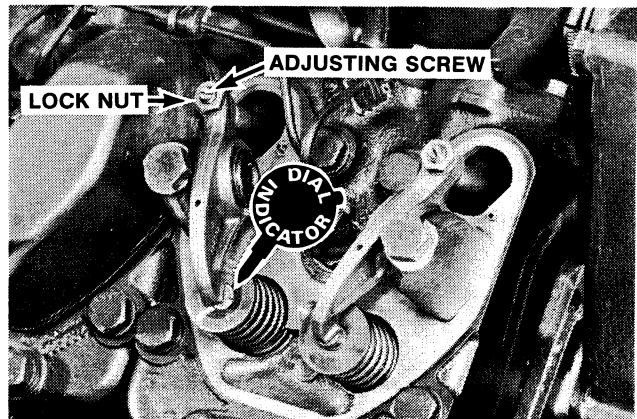

Put a dial indicator on the No. 1 cylinder intake valve spring guide and set the dial indicator at zero. Loosen the lock nut on the rocker arm adjusting screw. Turn the adjusting screw to remove all valve clearance and to open the valve 0.1 mm. Tighten the lock nut. Reset the dial indicator to zero.

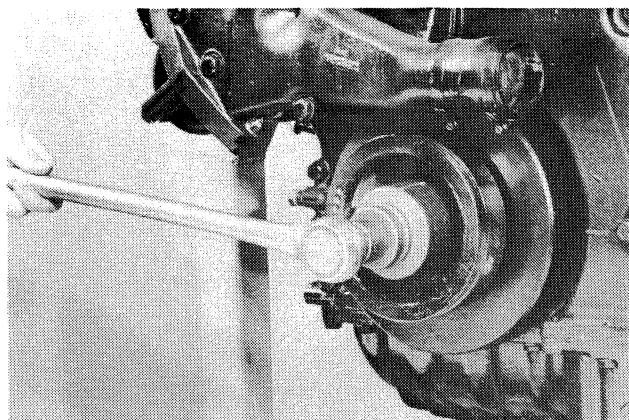
STEP 31

Turn the engine over clockwise, one complete revolution. The dial indicator must show a reading of 0.083 to 0.126 inch (2.1 to 3.2 mm) for the correct valve timing.

NOTE: If the 0.083 to 0.126 inch (2.1 to 3.2 mm) reading is not reached, the complete gear train assembly must be checked. See Section 2225 in this Service Manual to remove the timing gear cover and align the timing marks on the gears.

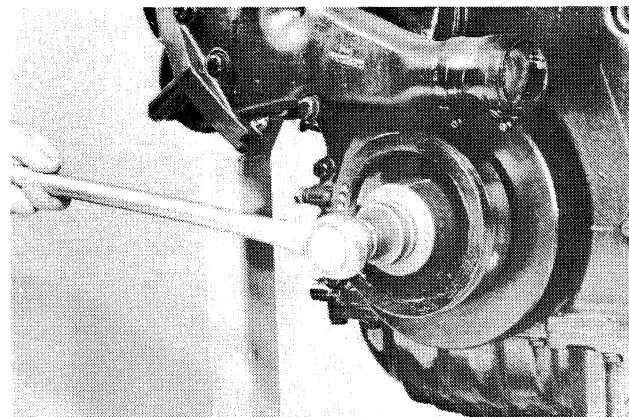
STEP 32

Turn the engine over clockwise one complete revolution until the No. 1 cylinder is in the compression stroke.

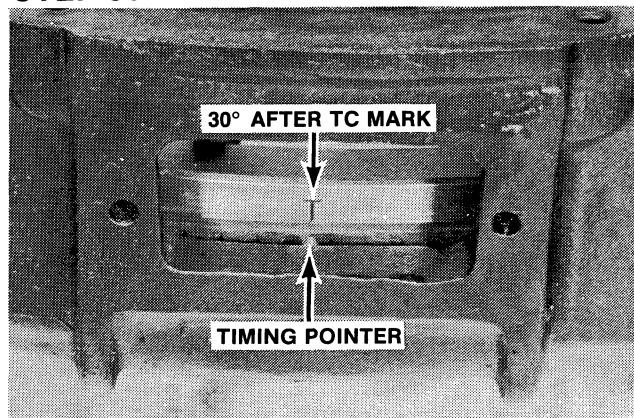
STEP 33

Continue to turn the engine clockwise, to align the 30° after TC mark on the flywheel with the timing pointer.

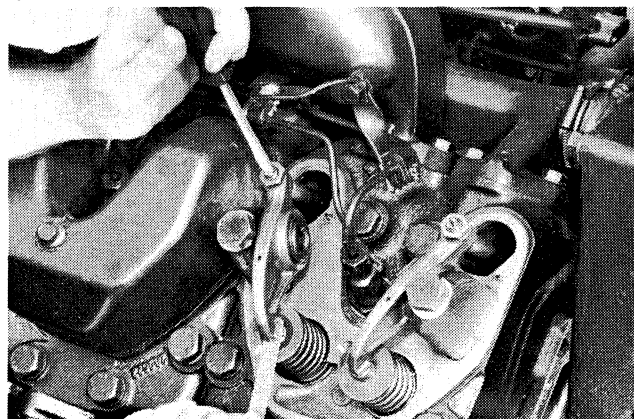
STEP 34

Adjust the valve clearance for the No. 1 cylinder intake valve to a clearance of 0.018 inch (0.45 mm). Tighten the lock nut on the adjusting screw to an approximate torque of 30 lb ft (40 Nm)(4.0 kgm).

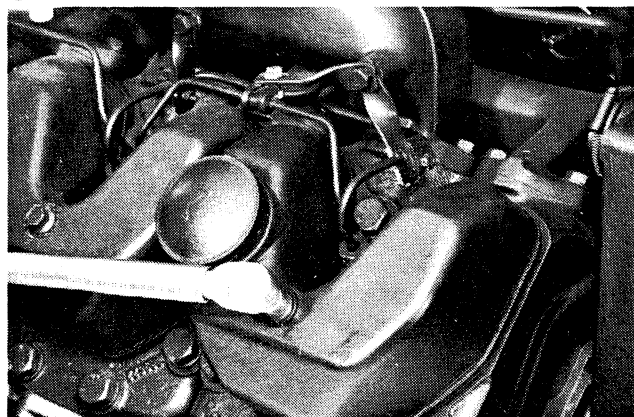
STEP 35

Install the valve cover on the cylinder head. Tighten the valve cover bolt to a torque of 124 lb in (14 Nm)(1.4 kgm).



Suggest:

If the above button click is invalid.

Please download this document

first, and then click the above link

to download the complete manual.

Thank you so much for reading

STEP 36

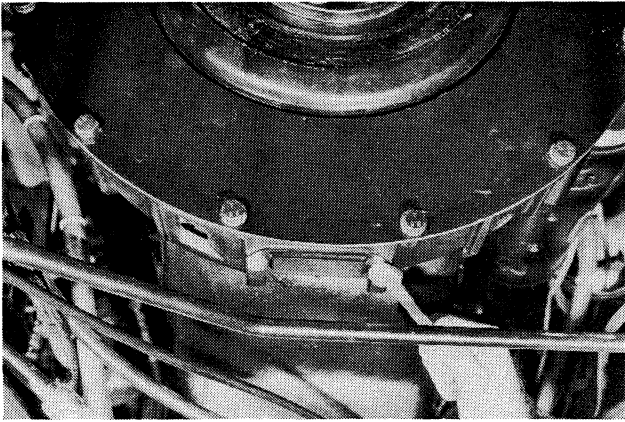

Install the cover over the timing hole in the bottom of the flywheel housing.

STEP 37

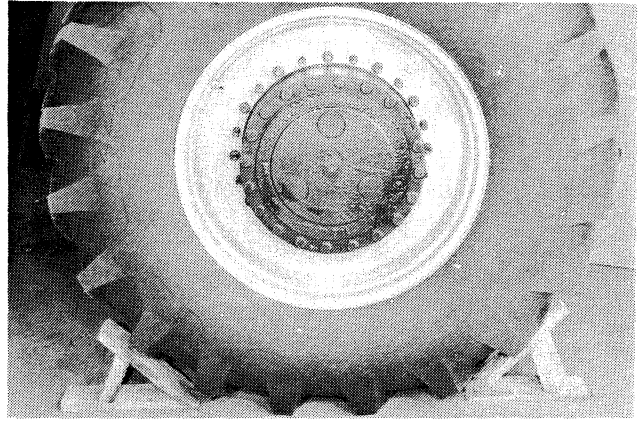

Remove the blocks from in front of and behind the tractor tires.

<https://www.ebooklibonline.com>

Hello dear friend!

Thank you very much for reading.

Enter the link into your browser.

The full manual is available for immediate download.

<https://www.ebooklibonline.com>