

3200 and 4200 Series Tractors

Service Manual Don 7-69134

Table of Contents

	Section	Pub. No.
1 GENERAL		
Safety Rules, General Information and Torque Specifications.....	1001*	8-86530
General Specifications and Torques	1002	7-39231
2 ENGINE		
Engine Removal	2001	7-69170
Cylinder Head.....	2415	7-69360
Cylinder Block.....	2425	7-69370
Lubrication System.....	2445	7-69330
Cooling System	2455	7-69280
3 FUEL SYSTEM		
Fuel System and Filters.....	3410	7-69340
Fuel Injection Pump.....	3412	7-69350
Fuel Injectors	3413	7-69380
4 ELECTRICAL		
Electrical Troubleshooting and Schematics.....	4001*	7-69001
Battery Servicing and Testing.....	4004	7-73210
5 STEERING		
Steering Hand Pump	5001	7-39240
2WD Steering Cylinder (For Tractors prior to PIN JJE0906096).....	5002	7-39250
2WD Steering Cylinder (For Tractors from PIN JJE0906096).....	5002	7-69440
Front Axle - 2WD Tractors.....	5003	7-36270
6 TRANSMISSION		
Transmission Cross Sectional Drawings.....	6000	7-69400
Engine Clutch and Flywheel (Rockford 12 inch and Laycock 11 inch).....	6001	7-39850
Separating the Tractor (between Engine and Speedbox)	6002	7-39860
Range Transmission Removal	6003	7-39871
Speed Transmission Removal.....	6004	7-39881
Speed Transmission Servicing.....	6005	7-39891
Powershift Transmission	6006	7-39900
Forward and Reverse Transmission.....	6007	7-39910
Creep Transmission	6008	7-39920
Range Transmission (For Tractors equipped with MFD).....	6009	7-39931
Range Transmission (For 2WD Tractors).....	6010	7-39941
MFD Transfer Gearbox, Drive Shaft and Parking Brake	6011	7-39951
Rear Axles	6012	7-39960
Differential	6013	7-39970
Steering Support (For Cab Tractors)	6014	7-69010
Steering Support (For Non-Cab Tractors)	6015	7-39090
PTO	6016	7-39100
MFD Axle.....	6021	7-39121

* Found in Schematic Sets Only

CASE CORPORATION
700 State Street
Racine, WI 53404 U.S.A.

CASE CANADA CORPORATION
450 Sherman Avenue
Hamilton, ON L8N 4C4 CANADA

Don 7-69114

© 1999 Case Corporation
Printed in U.S.A.
March 1995 (Revised May 1999)

Reprinted

7 BRAKES

Parking Brake (For 2WD Tractors).....	7001	7-39980
Rear Brakes (For Tractors prior to PIN JJE0908037)	7002	7-39990
Rear Brakes (For Tractors from PIN JJE0908037)	7002	7-69450
Brake Master Cylinder.....	7003	7-39130

8 HYDRAULICS

Hydraulic Troubleshooting and Schematic.....	8001*	7-39730
Hydraulic Hitch Adjustments	8005	7-39140
Multi Control Valve and Hydraulic Pump.....	8010	7-39150
Unloading and Flow Control Valve.....	8015	7-39160
Remote Valves	8025	7-39180
Hydraulic Housing Servicing	8035	7-39190
Hydraulic Housing Removal.....	8040	7-69260
Differential Lock Cylinder and Solenoid Valve	8060	7-39220

9 CHASSIS AND MOUNTED EQUIPMENT

Pedal, Lever and Switch Adjustments.....	9001*	7-39742
Air Conditioner Troubleshooting for Systems with HFC-134a Refrigerant (Visual and Operating)	9002	7-69031
Air Conditioner System Gauges and Testing for Systems with HFC-134a Refrigerant	9003	7-69041
Air Conditioner System Service for Systems with HFC-134a Refrigerant	9004	7-39001
Air Conditioner System Component Servicing for Systems with HFC-134a Refrigerant	9005	7-39010
XL Cab Removal	9006	7-39040
Low Profile Cab Removal.....	9007	N/A
Seat Platform and Fenders	9008	7-39060
XL Cab Servicing	9009	7-39070
Hood and Panels.....	9011	7-69270

*** Found in Schematic Sets Only**

7-69260

Section

1001

SAFETY, GENERAL INFORMATION AND TORQUE SPECIFICATIONS

<https://www.ebooklibonline.com>

Hello dear friend!

Thank you very much for reading.

Enter the link into your browser.

The full manual is available for immediate download.

<https://www.ebooklibonline.com>

GENERAL INFORMATION

CLEANING

Clean all metal parts except bearings, in mineral spirits or by steam cleaning. Do not use caustic soda for steam cleaning. After cleaning dry, and put oil on all parts. Clean oil passages with compressed air. Clean bearings in kerosene, dry the bearings completely and put oil on the bearings.

INSPECTION

Check all parts when the parts are disassembled. Replace all parts that have wear or damage. Small scoring or grooves can be removed with a hone or crocus cloth. Complete visual inspection for indications of wear, pitting and the replacement of parts necessary will prevent early failures.

BEARINGS

Check bearings for easy action. If bearings have a loose fit or rough action replace the bearing. Wash bearings with a good solvent or kerosene and permit to air dry. **DO NOT DRY BEARINGS WITH COMPRESSED AIR.**

NEEDLE BEARINGS

Before you press needle bearings in a bore always remove any metal protrusions in the bore or edge of the bore. Before you press bearings into position put petroleum jelly on the inside and outside diameter of the bearings.

GEARS

Check all gears for wear and damage. Replace gears that have wear or damage.

OIL SEALS, O-RINGS AND GASKETS

Always install new oil seals, o-rings and gaskets. Put petroleum jelly on seals and o-rings.

SHAFTS

Check all shafts that have wear or damage. Check the bearing and oil seal surfaces of the shafts for damage.

SERVICE PARTS

Always install genuine Case service parts, when ordering refer to the Parts Catalog for the correct part number of the genuine Case replacement items. Failures due to the use of other than genuine Case replacement parts are not covered by warranty.

LUBRICATION

Only use the oils and lubricants specified in the Operator's or Service Manual. Failures due to the use of non specified oils and lubricants are not covered by warranty.

STANDARD TORQUE DATA FOR NUTS AND BOLTS

Where no special torque data is specified, the following torque figures should be applied. Threads should be lubricated with engine oil or chassis grease.

TORQUE SPECIFICATIONS \pm 10%									
SIZE	GRADE 8.8			GRADE 10.9			GRADE 12.9		
	lb-ft	Nm	kg/m	lb-ft	Nm	kg/m	lb-ft	Nm	kg/m
5 mm	4	5.5	0.56	5.5	7.5	0.76	6.6	9	0.92
6 mm	6.6	9	0.92	9.2	12.5	1.27	11	15	1.53
8 mm	16.5	22.5	2.3	23	31.5	3.2	26.5	36	3.67
10 mm	32	44	4.5	45	62	6.3	55	75	7.65
12 mm	57	77.5	7.9	81	110	11.2	95	130	13.2
14 mm	88	120	12.2	125	170	17.3	155	210	21.4
16 mm	140	190	19.4	195	265	27	236	320	32.6
18 mm	192	260	26.5	269	365	37.2	320	435	44.3
20 mm	273	370	37.7	383	520	53	457	620	63.2
22 mm	369	500	51	516	700	71.4	619	840	85.6
24 mm	471	640	65.2	665	900	92	796	1080	110
27 mm	702	950	97	996	1350	137.7	1195	1620	165.2
30 mm	955	1300	132.5	1328	1800	183.6	1593	2160	220.3

TORQUE DATA FOR HYDRAULIC FITTINGS

FITTINGS, CONNECTIONS AND PLUGS

Diameter x Pitch	Newton / Metres	Pounds / Feet	Kilogram / Metres
10 mm x 1	20	14.5	2
12 mm x 1.5	35	26	3.6
14 mm x 1.5	45	33.2	4.6
16 mm x 1.5	60	44	6.1
18 mm x 1.5	70	51	7.1
22 mm x 1.5	100	73	10.2
27 mm x 2	200	147	20.4
33 mm x 2	280	207	28.6
42 mm x 2	380	281	38.8

NUTS FOR TUBES AND HOSES

Diameter x Pitch	Newton / Metres	Pounds / Feet	Kilogram / Metres
16 mm x 1.5	20	14.5	2
18 mm x 1.5	35	26	3.6
20 mm x 1.45	45	33.2	4.6
24 mm x 1.5	60	44	6.1

FLANGES

Diameter x Pitch	Newton / Metres	Pounds / Feet	Kilogram / Metres
8 mm x 1.5	28	21	2.9
10 mm x 1.5	55	41	5.6
12 mm x 1.75	90	67	9.2
14 mm x 2	145	107	14.8
16 mm x 2	230	170	23.5

Section

1002

GENERAL SPECIFICATIONS AND TORQUES

1002

CASE CORPORATION
700 State Street
Racine, Wi 53404 U.S.A.

CASE CANADA CORPORATION
3350 South Service Road
Burlington, ONL7N 3M6 CANADA

Don 7-39231

© 1995 Case Corporation
Printed in U.S.A.
March 1995

TABLE OF CONTENTS

GENERAL SPECIFICATIONS

Capacities	2
Engine Specifications	3
Fuel Specifications	8
Steering Specifications	9
Transmission Specifications	9
Brake Specifications	10
Hydraulic Specifications	11
Air Conditioner Specifications	13
 SPECIAL TORQUES	 14

GENERAL SPECIFICATIONS

Capacities

Coolant Capacity		
3 Cylinder Engines	11.4 litres	3.0 U.S. gal
4 Cylinder Engines	13.7 litres	3.6 U.S. gal
Engine Oil Capacity		
D-155, D-179 Engine	Without filter change 7.0 litres	1.8 U.S. gal
	With filter change 7.5 litres	2.0 U.S. gal
D-206 Engine	Without filter change 9.0 litres	2.4 U.S. gal
	With filter change 9.5 litres	2.5 U.S. gal
D-239, D-246, D-268, DT-268 Engine	Without filter change 9.3 litres	2.5 U.S. gal
	With filter change 9.8 litres	2.6 U.S. gal
Transmission/Hydraulic System Capacity		
2WD	34 litres	9.0 U.S. gal
MFD	36.5 litres	9.6 U.S. gal
MFD Axle		
Differential	5.0 litres	1.3 U.S. gal
Planetaries	0.6 litres	0.2 U.S. gal
Fuel Tank		
Tractor with Cab	112 litres	29.6 U.S. gal
Tractor without Cab	77 litres	20.3 U.S. gal
Front PTO	0.65 litres	0.2 U.S. gal

Engine Specifications

CYLINDER HEAD

Cylinder Head Maximum Warpage	0.12 mm	0.0047 inch
Cylinder Head Thickness		
New	98.81 to 99.31 mm	3.8902 to 3.9098 inch
Minimum After Machining	98.54 mm	3.8795 inch

NOTE: *The maximum amount of material that can be machined from the cylinder head face is 0.77 mm (0.030 inch).*

Inlet Valve Stem Diameter	9.935 to 9.945 mm	0.3912 to 0.3915 inch
Exhaust Valve Stem Diameter	9.995 to 9.965 mm	0.3920 to 0.3924 inch
Maximum Stem Clearance in Guide Before Reconditioning	0.15 mm	0.006 inch
Valve Clearance (Engine Warm) Inlet and Exhaust	0.30 mm	0.012 inch
Valve Seat Angle		45°
Distance of Cylinder Head Face to Valve Face		
Inlet	1.00 to 1.40 mm	0.04 to 0.05 inch
Exhaust	1.20 to 1.60 mm	0.047 to 0.06 inch
Valve Guides		
Outside Diameter	16.060 to 16.078 mm	0.6323 to 0.6330 inch
Inside Diameter	9.865 to 9.901 mm	0.3883 to 0.3893 inch
Inside Diameter (Reamed)	10.00 to 10.02 mm	0.3940 to 0.3945 inch
Distance from Top of Valve Guide to the		
Seat in Cylinder for Valve Rotator	28.0 mm	1.102 inch
Valve Seat Insert Thickness	8.75 mm	0.344 inch
Valve Seat Outside Diameter		
Standard	42.07 to 42.09 mm	1.656 to 1.657 inch
0.006 inch (0.15 mm) Oversize	42.22 to 42.24 mm	1.662 to 1.663 inch
0.016 inch (0.40 mm) Oversize	42.47 to 42.49 mm	1.672 to 1.673 inch
Minimum Valve Seat Contact Width	1.50 mm	0.059 inch
Cylinder Head Counterbore Diameter for Valve Seat Insert		
Standard	42.000 to 42.020 mm	1.653 to 1.654 inch
0.006 inch (0.15 mm) Oversize	42.150 to 42.170 mm	1.659 to 1.660 inch
0.016 inch (0.40 mm) Oversize	42.400 to 42.420 mm	1.669 to 1.670 inch
Counterbore Depth from Cylinder Head Face	12.24 to 12.29 mm	0.482 to 0.484 inch
Valve Springs		
Free Length	54.00 +/- 1.50 mm	2.125 +/- 0.059 inch
Rocker Shaft Outside Diameter	21.56 to 21.59 mm	0.848 to 0.850 inch
Rocker Arm Bushing Diameter	21.62 to 21.64 mm	0.851 to 0.852 inch
Rocker Shaft Spring		
Free Length	21.671 to 21.63 mm	0.850 to 0.851 inch
Free Length	37.70 mm	1.484 inch
Push Rods Effective Length		
D-155, D-206	176.50 to 177.00 mm	6.949 to 6.968 inch
D-179, D-239, D-246	211.00 to 211.50 mm	8.307 to 8.326 inch
D-268, DT-268	216.50 to 217.00 mm	8.524 to 8.543 inch

PISTONS

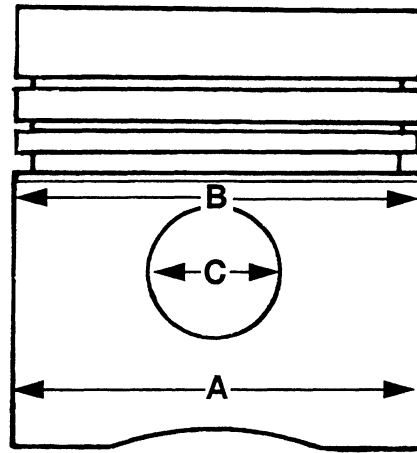

2425P1

Piston Clearance in Cylinder Liner measured 90° degrees to Piston Pin Hole
 Diameter A measured at a Height of 4.0 mm (0.157 inch) 0.09 to 0.13 mm
 Diameter B measured at a Height of 50.0 mm (1.968 inch) 0.15 to 0.20 mm

0.0035 to 0.0050 inch
 0.0059 to 0.0079 inch

Diameter of Piston Pin Hole C

D-155, D-179, D-206, D-239, D-246, D-268 35.997 to 36.002 mm
 DT-268 38.00 mm (+ 0.002 - 0.003)

1.4172 to 1.4174 inch
 1.4960 inch(+ 0.00007 - 0.0001)

Piston Ring Gap

Compression Rings 0.35 to 0.55 mm
 Oil Control Ring 0.25 to 0.40 mm

0.014 to 0.022 inch
 0.010 to 0.016 inch

Piston Pin Diameter

D-155, D-179, D-206, D-239, D-246, D-268 35.987 to 35.991 mm
 DT-268 37.987 to 37.991 mm

1.4168 to 1.4170 inch
 1.4955 to 1.4957 inch

Protrusion of Pistons

D-155, D-206 Engines (with a 111.1 mm Stroke) 0.32 to 0.70 mm
 D-179, D-239 Engines (with a 128.52 mm Stroke) 0.36 to 0.74 mm
 D-268, DT-268 Engines (with a 139.77 mm Stroke) 0.36 to 0.74 mm

0.0126 to 0.027 inch
 0.0141 to 0.029 inch
 0.0141 to 0.029 inch

CONNECTING RODS

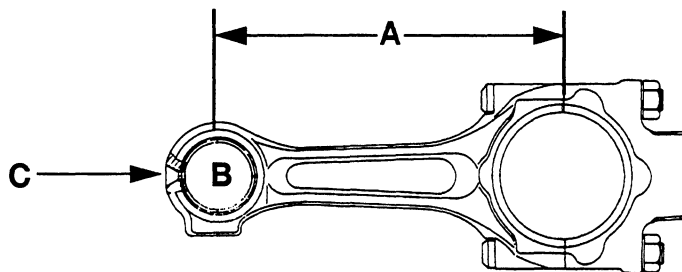

Dimension A

D-155, D-206 187.96 to 188.01 mm
 D-179, D-239, D-246, D-268, DT-268 213.84 to 213.89 mm

7.400 to 7.402 inch
 8.419 to 8.421 inch

Dimension B

D-155, D-179, D-206, D-239, D-246, D-268 36.012 to 36.022 mm
 DT-268 38.026 to 38.036 mm

1.4178 to 1.4182 inch
 1.4970 to 1.4974 inch

Dimension C 4.0 mm

0.16 inch

Connecting Rod to Crankshaft Side Clearance 0.16 to 0.25 mm

0.006 to 0.010 inch

CYLINDER LINERS

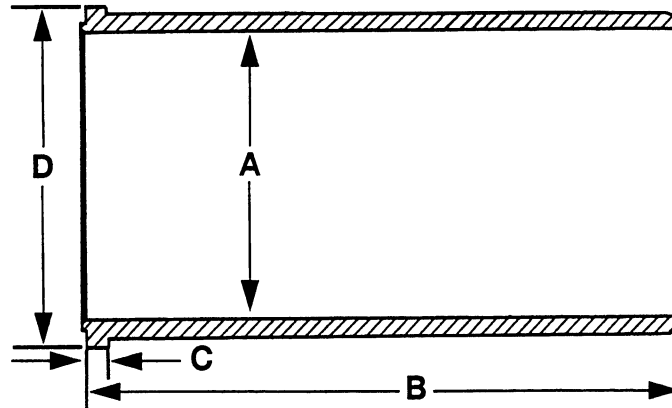

Dimension A

D-155, D-179, D-206, D-239	98.425 to 98.449 mm	3.8750 to 3.8759 inch
D-246, D-268, DT-268	100.00 to 100.24 mm	3.9370 to 3.9379 inch

Dimension B

D-155, D-206	200 mm	7.874 inch
D-179, D-239, D-246, D-268, DT-268	215 mm	8.464 inch

Dimension C	7.700 to 7.715 mm	0.3031 to 0.3037 inch
-------------------	-------------------	-----------------------

Dimension D	119 mm	4.685 inch
-------------------	--------	------------

Cylinder Liner Protrusion	0.08 to 0.12 mm	0.0031 to 0.0047 inch
---------------------------------	-----------------	-----------------------

Maximum Warpage of Surface	0.04 mm	0.0016 inch
----------------------------------	---------	-------------

O-Ring Groove Diameter

(New) Golden Tracers	118.32 to 118.58 mm	4.658 to 4.668 inch
(Old) Red Tracers	118.54 to 118.80 mm	4.667 to 4.677 inch

BALANCER (4 Cylinder Engines only)

Backlash Balancer Drive Gear to Crankshaft Gear

D-206, D-239, D-246	0.25 to 0.40 mm	0.010 to 0.016 inch
D-268, DT-268	0.23 to 0.50 mm	0.009 to 0.020 inch

Backlash Balancer Gear	0.18 to 0.23 mm	0.007 to 0.009 inch
------------------------------	-----------------	---------------------

CYLINDER BLOCK

Cylinder Block Surface Maximum Warpage	0.12 mm	0.0047 inch
--	---------	-------------

Cylinder Block Surface Height from Centerline of Crankshaft

D-155, D-206	309.842 to 309.908 mm	12.198 to 12.201 inch
--------------------	-----------------------	-----------------------

D-179, D-239, D-246	344.386 to 344.462 mm	13.558 to 13.561 inch
---------------------------	-----------------------	-----------------------

D-268, DT-268	353.386 to 353.462 mm	13.912 to 13.915 inch
---------------------	-----------------------	-----------------------

CRANKSHAFT

Crankshaft Journals and Crankpins

Maximum Out of Round per 25mm (1 inch)	0.004 mm	0.00015 inch
--	----------	--------------

Maximum Taper per 25 mm (1 inch)	0.004 mm	0.00015 inch
--	----------	--------------

Crankshaft Rear Sealing Flange

Permitted Run-out	0.050 mm	0.002 inch
-------------------------	----------	------------

Permitted Out of True	0.020 mm	0.00078 inch
-----------------------------	----------	--------------

Crankshaft Main Bearing Clearance (New Inserts)	0.070 to 0.14 mm	0.00275 to 0.00551 inch
---	------------------	-------------------------

Crankshaft End Float	0.15 to 0.23 mm	0.006 to 0.009 inch
----------------------------	-----------------	---------------------

Connecting Rod Bearing Clearance (New Inserts)	0.06 to 0.12 mm	0.0023 to 0.0047 inch
--	-----------------	-----------------------

Crankshaft Balancer Ring Gear to Drive Weight Gear Backlash

D-206, D-239, D-246	0.25 to 0.40 mm	0.010 to 0.016 inch
---------------------------	-----------------	---------------------

D-268, DT-268	0.23 to 0.50 mm	0.009 to 0.020 inch
---------------------	-----------------	---------------------

Section 2001

2001

ENGINE REMOVAL

CASE CORPORATION
700 State Street
Racine, Wi 53404 U.S.A.

CASE CANADA CORPORATION
3350 South Service Road
Burlington, ONL7N 3M6 CANADA

Don 7-69170

© 1994 Case Corporation
Printed in U.S.A.
December 1994

TABLE OF CONTENTS

ENGINE

Removal and Installation (all models)	2
Engine Removal (Tractors with Cab)	3
Engine Removal (Tractors without Cab)	4

ENGINE

Removal and Installation (all models)

STEP 1

Park the machine on hard level ground, apply the parking brake and stop the engine. Put blocks in front of and behind the rear wheels.

STEP 2

Remove the Hood and Side Panels, refer to Section 9011.

STEP 3

Disconnect the battery, negative (-) terminal first.

NOTE: For Installation, connect the positive (+) terminal first.

NOTE: For Tractors without Cab, remove the battery.

STEP 4

Remove the radiator, refer to Section 2455.

STEP 5

Strip away the Air Conditioning Components (if equipped), refer to Section 9005.

STEP 6

If the tractor is equipped with MFD, remove the MFD Drive Shaft, refer to Section 6011.

STEP 7

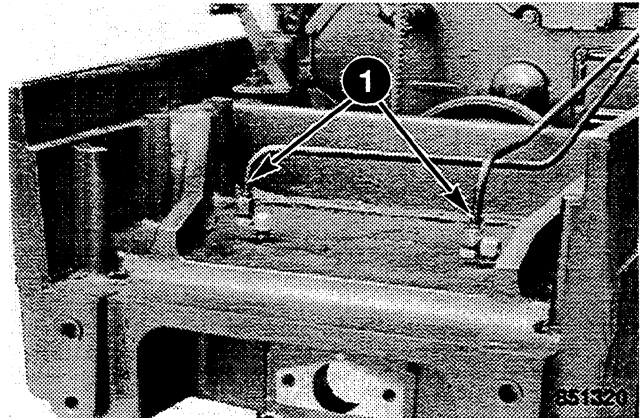

Disconnect and cap the hydraulic steering tubes (1).

STEP 8

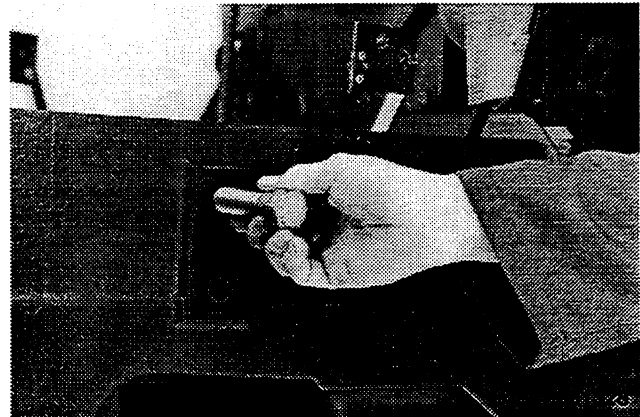

Install two 5/8 x 2 1/2 inch UNC bolts into each side of the front bolster.

STEP 9

Install wooden wedges between the front axle and front bolster.

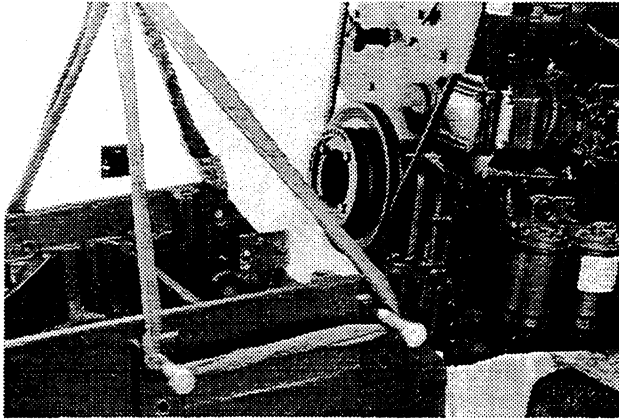
STEP 10

Attach suitable lifting equipment to the front bolster. Support the front of the engine using suitable stands. Remove the front bolster retaining bolts.

STEP 11

Raise the front of the engine to allow clearance for the front pulley and carefully move the front bolster and front axle from the engine.

NOTE: Move the front bolster and front axle away from the engine, carefully support the complete assembly on suitable stands.

Engine Removal (Tractors with Cab)

NOTE: For Tractors without Cab, refer to Step 21.

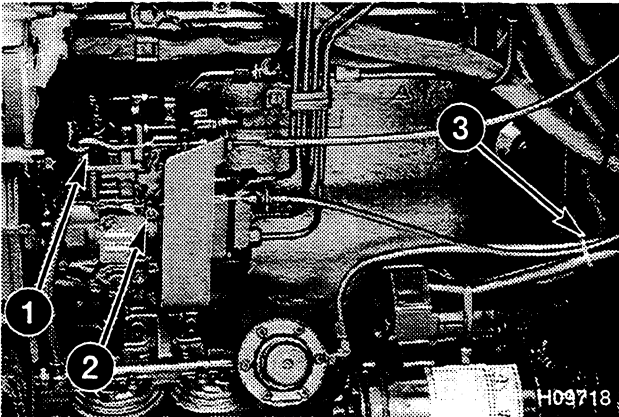
STEP 12

Disconnect the engine stop control cable (1) and the throttle control cable (2) from the fuel pump. Remove the tie strap (3) from the engine stop control cable and battery cable.

NOTE: For Installation, refer to Section 9001 for cable adjustment.

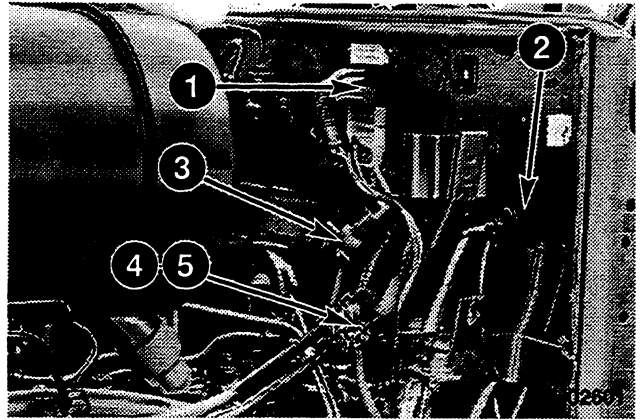
STEP 13

Disconnect the engine harness (1) and the steering support ground cable (2) from the steering support. Disconnect the circuit breaker (3) from the cab harness. Put identification marks on the hydraulic steering hoses (4) and (5). Disconnect and cap the hoses and tubes.

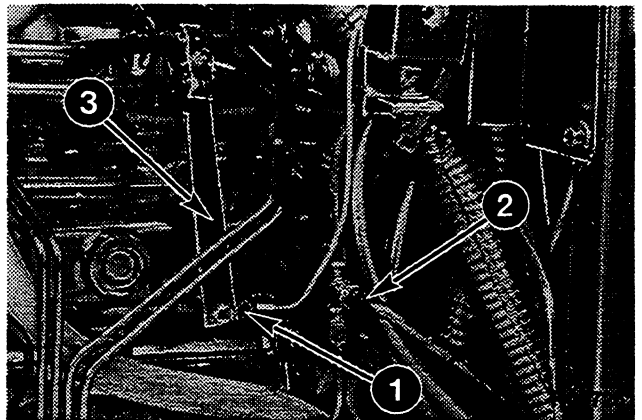
STEP 14

Disconnect the cab harness ground cable (1) and the fuel return tube (2). Disconnect the bracket (3) from the inlet manifold and remove the hydraulic steering tubes.

STEP 15

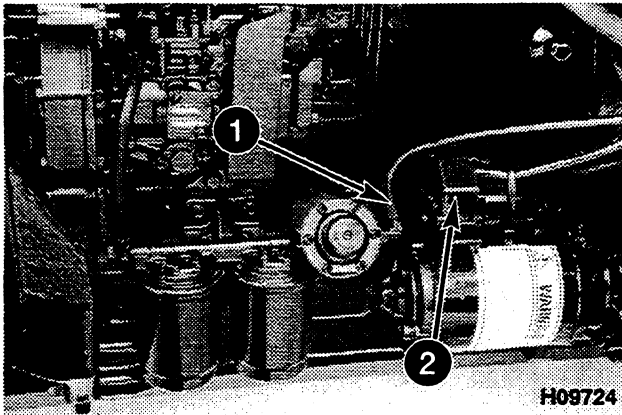

Disconnect and cap the fuel supply tube (1). Remove the cover (2) and disconnect the wiring connections from the starter motor.

NOTE: For Tractors with 3 cylinder engines, the fuel supply tube is located on the RH side of the engine.

STEP 16

Disconnect the engine heater hoses (both sides).

STEP 17

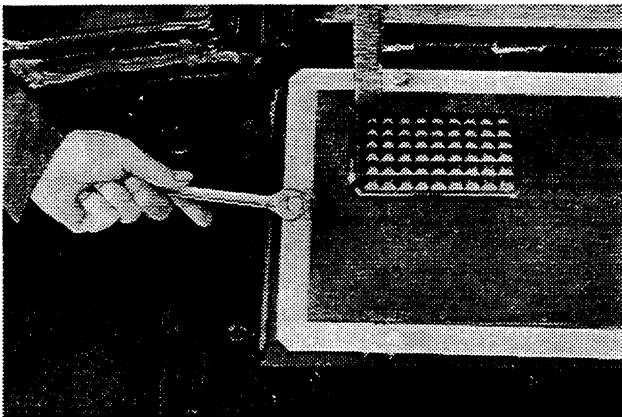

Remove the cab floor mat and the floor inspection plate.

STEP 18

Install a suitable lifting eye into the rear engine mounting hole.

STEP 19

Attach suitable lifting equipment to the engine. Support the front of the Speed Transmission using suitable stands. Remove the clutch housing bolts.

STEP 20

Make sure all parts are disconnected and remove the engine assembly.

NOTE: Before connecting the Engine and Speed Transmission, lubricate the splines of the friction plate and the pressure plate with **MOLYKOTE D321R** or equivalent.

NOTE: For Installation, follow the same procedure in reverse order.

Engine Removal (Tractors without Cab)

STEP 21

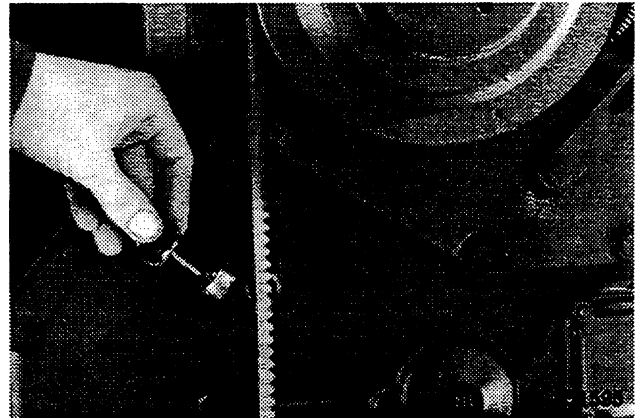

Disconnect the tachometer cable from the engine timing cover.

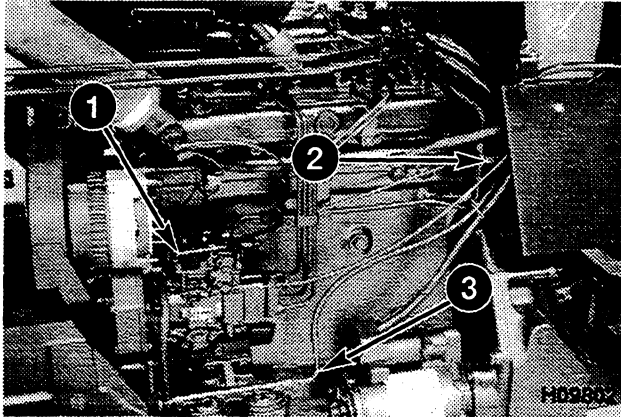
STEP 22

Disconnect the engine stop control cable (1), fuel return tube (2) and fuel supply tube (3).

NOTE: For Tractors with 3 cylinder engines, the fuel supply tube (3) is located on the RH side of the engine.

NOTE: For Installation, install the engine stop control cable (1), refer to Section 9001 for cable adjustment.

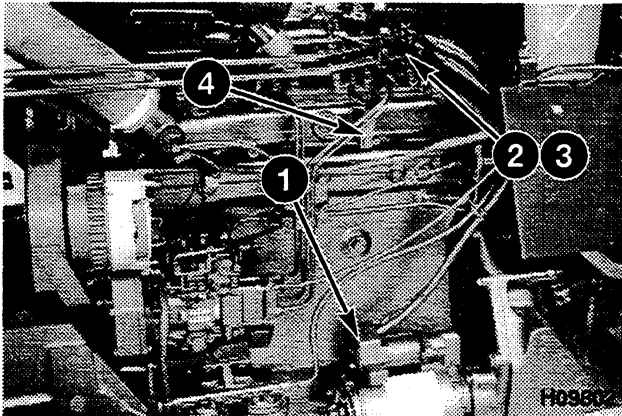
STEP 23

Remove the cover (1) and disconnect the electrical wiring from the starter motor. Put identification marks on the hydraulic steering hoses (2) and (3). Disconnect and cap the hoses and tubes. Disconnect the bracket (4) from the inlet manifold and remove the hydraulic steering tubes.

STEP 24

Label and disconnect the wiring harness connections from the horn and engine components. Move the harness clear of the engine.

STEP 25

Remove the down swept exhaust, (if equipped).

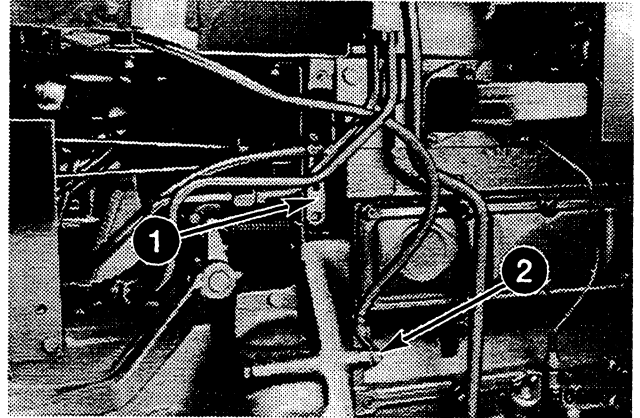
STEP 26

Remove the split pin and disconnect the throttle linkage (1). Disconnect the ground cable (2).

STEP 27

Attach suitable lifting equipment to the engine. Support the front of the Speed Transmission using suitable stands. Remove the clutch housing bolts.

STEP 28

Make sure all parts are disconnected and remove the engine assembly.

NOTE: Before connecting the Engine and Speed Transmission, lubricate the splines of the friction plate and the pressure plate with MOLYKOTE D321R or equivalent.

NOTE: For Installation, follow the same procedure in reverse order.

CYLINDER HEAD

Removal and Installation

NOTE: The Removal and Installation procedure is the same for both 3 and 4 cylinder engines unless otherwise stated.

NOTE: Some of the following Steps show the engine removed from the machine. This is for photographic purposes only.

STEP 1

Park the machine on hard, level ground, apply the parking brake and stop the engine. Put blocks in front of and behind the rear wheels.

STEP 2

Disconnect the battery, negative (-) terminal first.

NOTE: For Installation, connect the positive (+) terminal first.

STEP 3

Remove the Hood and Side Panels, refer to Section 9011.

STEP 4

Put a suitable container under the engine. Remove the plug from the cylinder block and drain the coolant.



Hot coolant can spray out when the radiator filler cap or drain plugs are removed. First allow the system to cool then turn the filler cap to the first notch and wait until the pressure is released.

NOTE: For Installation, fill the radiator with coolant to the correct level, start the engine and run at half throttle for 10 minutes. Stop the engine. Check for and repair any leaks. Check the coolant level in the radiator and add coolant if necessary.



Never operate the engine in a closed building. Proper ventilation is required under all circumstances.

STEP 5

Remove the air filter assembly and disconnect the thermostart from the inlet manifold.

NOTE: For tractors with ether start, remove the ether start system.

STEP 6

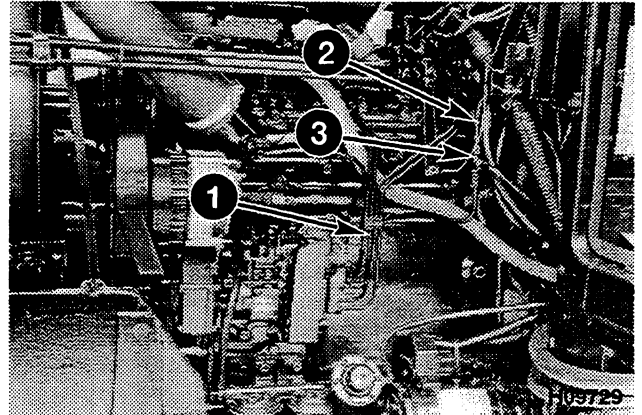

Disconnect, cap and remove the high pressure tubes (1) from the injection pump and injectors. Disconnect and cap the injector spill line (2) at the tee fitting (3).

NOTE: For Installation, tighten the high pressure tubes (1) to a torque of 50 to 70 Nm (36 to 51 lb ft).

STEP 7

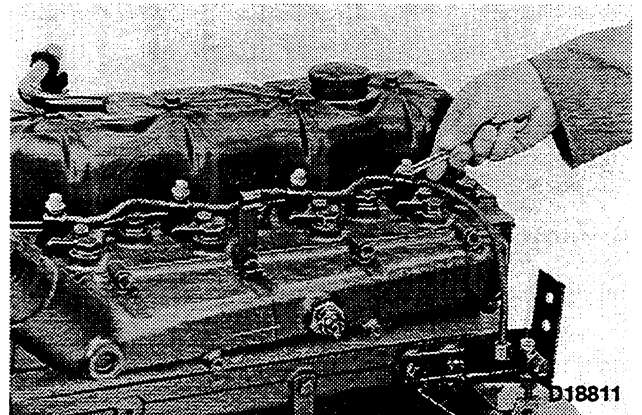

Disconnect the spill return fitting from the side of the injectors. Remove and discard the copper washers from both sides of the fitting.

NOTE: For Installation, install new copper washers on both sides of the fitting. Install the fitting and tighten to a torque of 2 to 8 Nm (1.5 to 6 lb ft).

STEP 8

For tractors without cab, disconnect the tachometer cable from the engine timing cover.

STEP 9

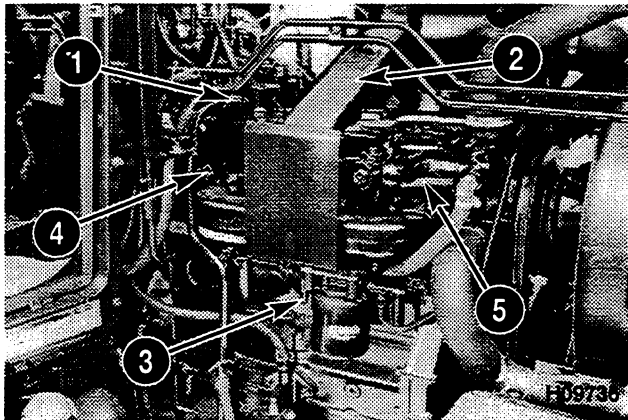

Disconnect the breather (1) from the rocker cover. Remove the exhaust elbow (2). Remove the rear tube (3) from the coolant filter conditioner and remove the filter bracket. Remove the brake tube support bracket (4), loosen the clips on the coolant hose (5) at the water manifold.

STEP 10

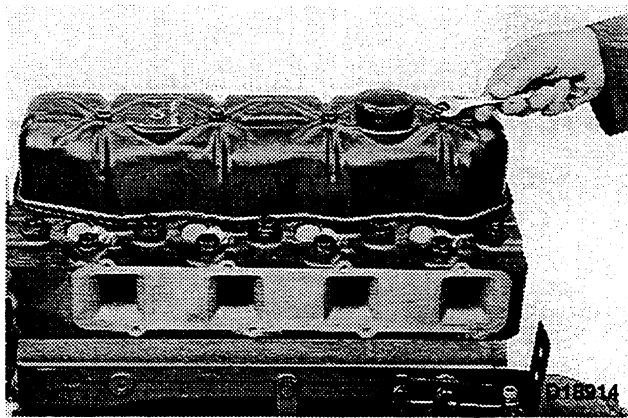

Remove the rocker cover and discard the gasket.

NOTE: For Installation, install a new rocker cover gasket and rubber sealing washers on the rocker cover retaining bolts. Tighten the bolts to a torque of 20 to 27 Nm (15 to 20 lb ft).

STEP 11

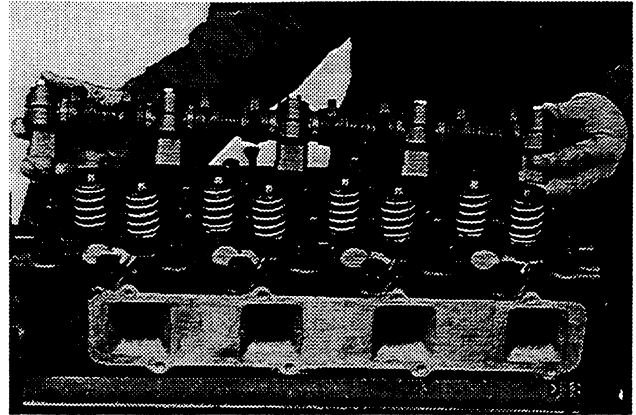

Remove the rocker shaft assembly from the cylinder head and remove the push rods.

NOTE: For Installation, make sure the punch mark on the end of the rocker shaft is aligned with the slot in the front rocker arm support bracket (refer to Step 50), make sure the push rods locate into the ends of the rocker arm adjusting screws. Tighten the rocker shaft retaining bolts to a torque of 60 to 70 Nm (44 to 51 lb ft). If the bolts cannot be located into the cylinder head, loosen the clamping bolts on the rocker shaft support brackets. Tighten the clamping bolts after installing the rocker shaft retaining bolts.

NOTE: For Installation, adjust the inlet and exhaust valve clearances to 0.30 mm (0.012 inch) in the sequences shown below.

4 CYLINDER ENGINE

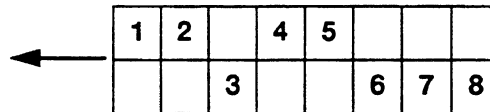

Put number 1 piston at T.D.C on the compression stroke and adjust valves 1, 2, 4 and 5.

Put number 4 piston at T.D.C on the compression stroke and adjust valves 3, 6, 7 and 8.

3 CYLINDER ENGINE

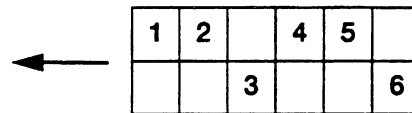

Put number 1 piston at T.D.C on the compression stroke and adjust valves 1, 2, 4 and 5..

Put number 1 piston at T.D.C on the exhaust stroke and adjust valves 3 and 6.

STEP 12

Remove the cylinder head retaining bolts.

NOTE: For Installation, the cylinder head bolts are two different lengths. The 127 mm (5 inch) bolts are positioned along the outer rows and the 146 mm (5.75 inch) bolts are positioned along the inner rows. Tighten the cylinder head bolts in three stages in the sequence shown:

4 CYLINDER ENGINE

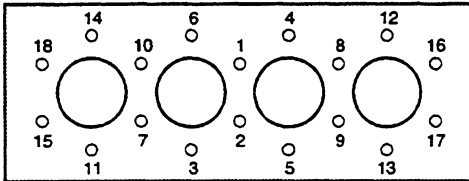

3 CYLINDER ENGINE

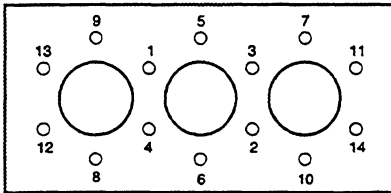

- 1st Stage 50 Nm (37 lb ft)
- 2nd Stage 100 Nm (74 lb ft)
- 3rd Stage 150 Nm (110 lb ft)

STEP 13

Install suitable lifting equipment and remove the cylinder head, put the cylinder head assembly onto a clean work bench. Remove and discard the cylinder head gasket.

NOTE: For Installation, install the cylinder head gasket, make sure the cylinder head locates on the two dowels in the cylinder block.

STEP 14

Use compressed air to remove dirt and dust from the cylinder bores and bolt holes. Make sure the cylinder block and head surfaces are clean and free of old gasket material.

NOTE: For Installation, follow the same procedure in reverse order.

Disassembly and Assembly

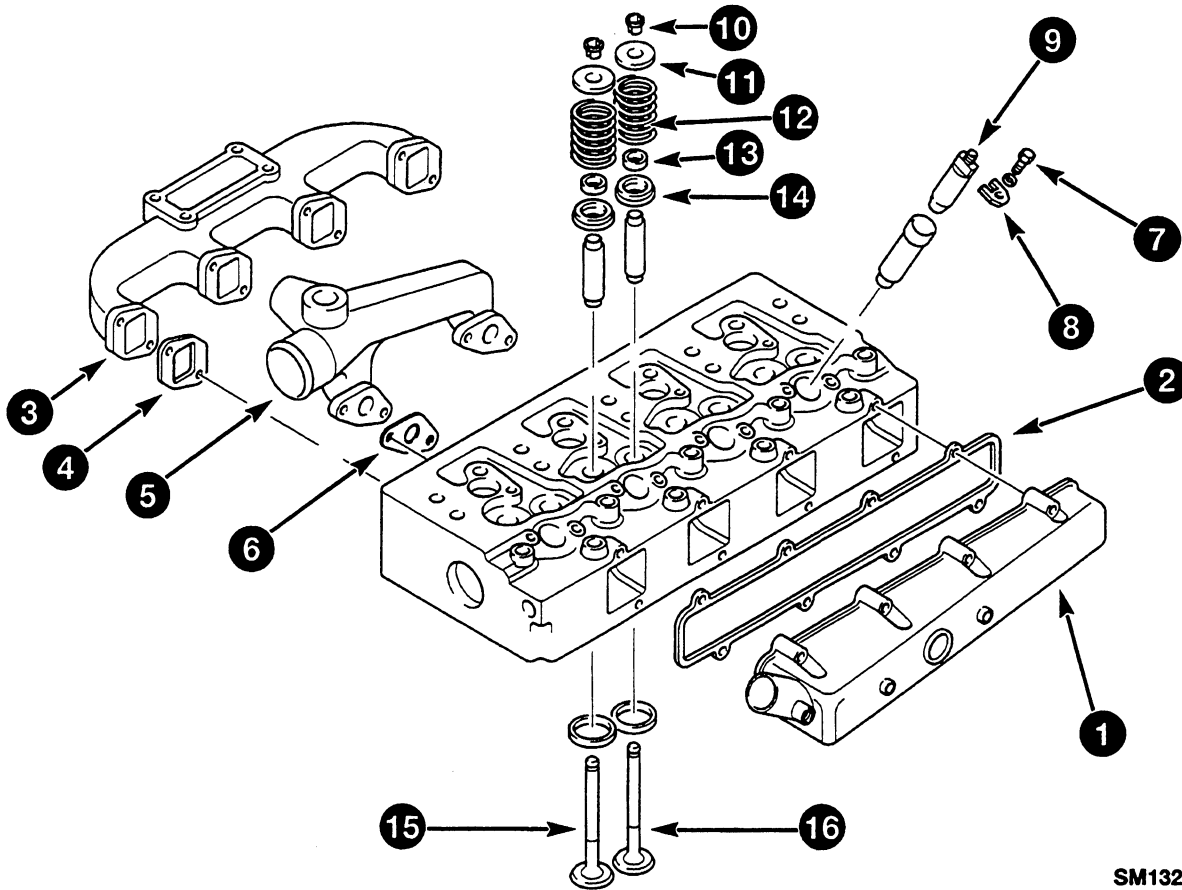

SM1329

NOTE: Items are numbered in order of Disassembly, Assembly is in reverse order of Disassembly.

- 1. MANIFOLD INLET
- 2. GASKET
- 3. MANIFOLD EXHAUST
- 4. GASKET
- 5. MANIFOLD COOLANT
- 6. GASKET
- 7. BOLT
- 8. RETAINER

- 9. INJECTOR
- 10. COLLET
- 11. VALVE SPRING RETAINER
- 12. VALVE SPRING
- 13. VALVE STEM SEAL
- 14. VALVE SPRING SEAT
- 15. VALVE EXHAUST
- 16. VALVE INLET

STEP 15

Remove the inlet manifold (1) and discard the gasket (2).

NOTE: For Installation, apply sealant B17555 and install a new gasket (2). Install the inlet manifold bolts and tighten to a torque of 35 to 40 Nm (25 to 29 lb ft).

STEP 16

Remove the exhaust manifold (3) and discard the gasket (4).

NOTE: For Installation, install a new gasket (3). Install the exhaust manifold nuts and tighten to a torque of 35 to 40 Nm (25 to 29 lb ft).

STEP 17

Remove the coolant manifold (5) and discard the gasket (6).

NOTE: For Installation, apply sealant B17555 and install a new gasket (6).

STEP 18

Remove the bolt (7) and retainer (8). Remove the injector (9). Repeat the procedure to remove the remaining injectors.

NOTE: For Installation, install a new o-ring onto the injector (9).

STEP 19

Mark the heads of the valves for easy assembly. Install the valve spring compressor and compress the valve spring (12).

STEP 20

Remove the two collets (10) from the valve spring retainer (11), remove the valve spring retainer (11). Remove the valve spring (12).

STEP 21

Remove and discard the valve stem seal (13). Remove the valve spring seat (14).

NOTE: For Installation, install a new valve stem seal (13), push the seal down the stem until it locates in the groove of the valve guide.

STEP 22

Remove the valve (15) and (16) from the cylinder head. Repeat the procedure to remove the remaining valves. The following valve removal sequence is from the front of the engine:

4 CYLINDER ENGINE

1 2 3 4 5 6 7 8
 exhaust, inlet, exhaust, inlet, exhaust, inlet, exhaust, inlet.

3 CYLINDER ENGINE

1 2 3 4 5 6
 exhaust, inlet, exhaust, inlet, exhaust, inlet.

NOTE: For Installation, lubricate the valve stems with clean engine oil and install the valves into the cylinder head.

Inspection

STEP 23

Clean the cylinder head in cleaning solvent and remove all traces of carbon and old gasket materials.

STEP 24

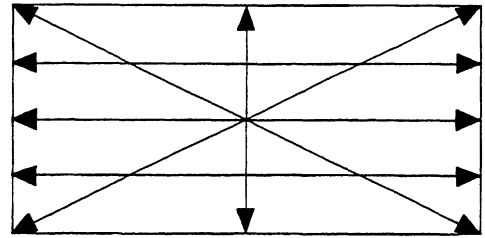

2415CH

Check the cylinder head surface for warpage using a straight edge and feeler gauge in the positions shown.

IMPORTANT: If the warpage is more than 0.12 mm (0.047 inch) the cylinder head must be machined or replaced. Refer to Specifications on Page 3.

STEP 25

Measure the height of the cylinder head. Replace the cylinder head if the height is less than 98.54 mm (3.8795 inch).

NOTE: The maximum amount of material that can be machined from the cylinder head is 0.77 mm (0.030 inch).

STEP 26

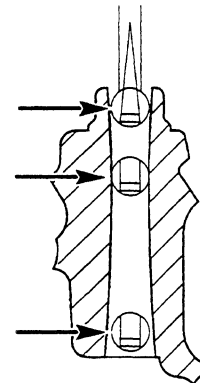

SM1351

Measure the wear in the valve guide bore with a bore gauge. Measure the wear in three positions as shown. If the bore of the valve guide is more than 10.17 mm (0.400 inch) the valve guide must be replaced, refer to Page 10.

STEP 27

Measure the free length of the valve springs. If the free length is less than 54 mm (2.125 inch) replace the spring.

VALVE GUIDES

Removal and Installation

STEP 28

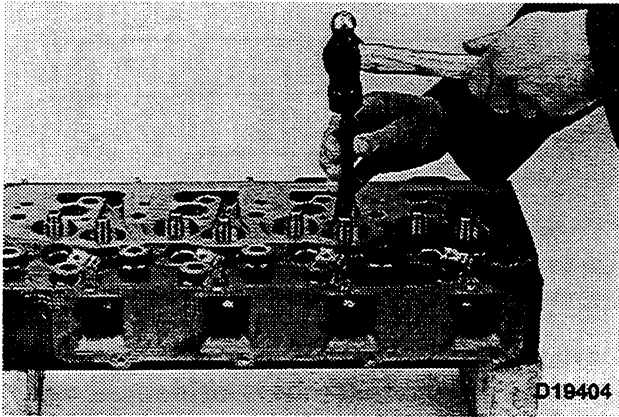

Use a bushing driver to remove the guide from the cylinder head.

STEP 29

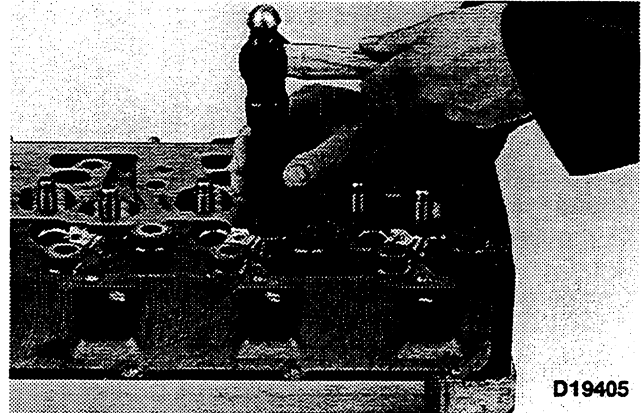

Install the new valve guide with the special tool 3055699R1 until the special tool contacts the cylinder head.

STEP 30

Install the valve guide reamer, 04-478-1, and ream the bores of the guides to a size of 10.00 to 10.02 mm (0.3940 to 0.03945 inch).

INLET AND EXHAUST VALVE

Inspection

STEP 31

Use a wire brush to clean the valves, care must be taken not to damage the valve stems.

STEP 32

Check the valves for the following conditions and replace if necessary.

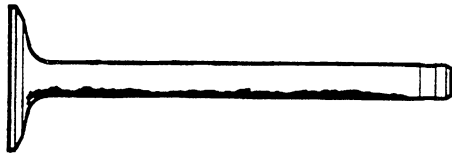

Worn Valve Stems

This condition can be caused by:

1. Restriction in oil supply to the rocker shaft.
2. Excessive cylinder head temperatures.
3. Operating the engine under extreme load conditions.

STEP 33



2415B

Heavy Carbon and Varnish Deposits

This condition can be caused by:

1. Worn valve guides and seats.
2. Worn valve stem oil seals.
3. Worn pistons and rings.
4. Engine not reaching operating temperature.

STEP 34



2415C

Rust or Pitting on Valve Stems

This condition can be caused by:

1. Using poor grade lubricants and fuel.
2. Failing to use an inhibitor to protect the engine during long storage periods.

STEP 35

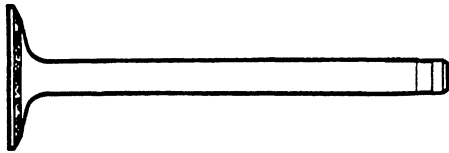

2415D

Rust or Pitting on Valve Face

This condition can be caused by using poor grade fuel and lubricants.

STEP 36

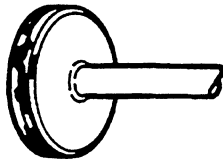

2415E

Deep Burns to Valve Face

This condition can be caused by:

1. Running at excessive loads and temperatures.
2. Grinding the valve face seat too narrow.

STEP 37



2415F

Worn Collet Grooves and Stem Tips

Replace the valve if either of the above conditions are present.

NOTE: Also check the condition of the valve spring retainer and collets. Replace if necessary.

STEP 38

The following is normal for both inlet and exhaust valves.

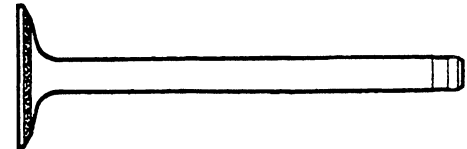

2415G

Very fine pitting to the valve and seat faces. If this condition is present it will not be necessary to reface the valves or seats.

Measure the stems on the inlet and exhaust valves. Replace the valves if the measurements are not within the specifications.

STEP 39

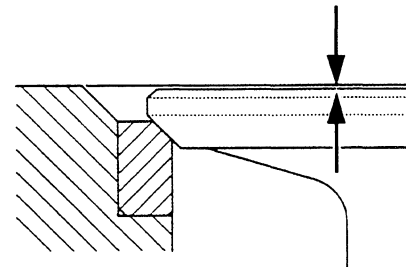

SM1332

Measure the clearance from the face of the valve to the face of the cylinder head. The clearance must be :

- Inlet valve 1.0 to 1.4 mm (0.04 to 0.05 inch)
- Exhaust valve 1.2 to 1.6 mm (0.047 to 0.06 inch)

NOTE: If the measurement is more than specified replace the valve and/or seat. If the measurement is less than specified grind the valve seat.



Suggest:

If the above button click is invalid.

Please download this document

first, and then click the above link

to download the complete manual.

Thank you so much for reading

EXHAUST VALVE SEAT

Installation

NOTE: If new valve seat inserts are required it is recommended that you have a qualified engine shop machine the cylinder head to the following Specifications.

NOTE: Replacement valve seat inserts are available for exhaust valves only, oversize in 0.15 mm (0.006 inch) and 0.40 mm (0.015 inch).

STEP 40

Machine the Cylinder Head to the following Specifications for Valve Seat Inserts:

Cylinder Head Counterbore Diameter for Valve Seat Insert.

0.15 mm (0.006 inch) Oversize Insert	42.150 to 42.170 mm (1.659 to 1.660 inch)
0.40 mm (0.016 inch) Oversize Insert	42.400 to 42.420 mm (1.669 to 1.670 inch)

Counterbore Depth from Cylinder Head Face

12.24 to 12.29 mm (0.482 to 0.484 inch)

Valve Seat Outside Diameter

0.15 mm (0.006 inch) Oversize Insert	42.22 to 42.24 mm (1.662 to 1.663 inch)
0.40 mm (0.016 inch) Oversize Insert	42.47 to 42.49 mm (1.672 to 1.673 inch)

STEP 41

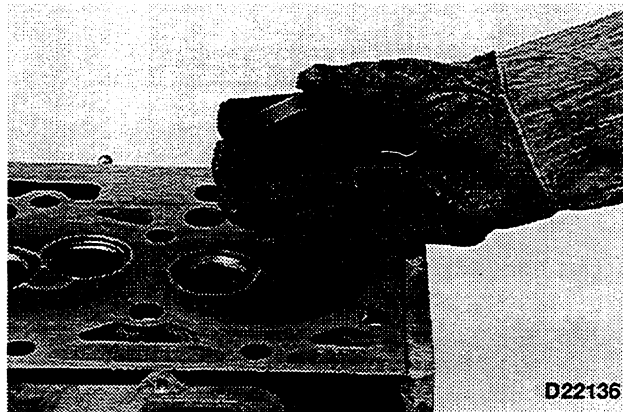

D22136

Put the valve seat inserts in dry ice until the temperature falls to - 60°C (- 76°F). Install the valve seat insert into the cylinder head. Make sure the valve insert is fully seated in the cylinder head by using a bushing driver.



Always wear protective gloves or mittens when handling frozen parts.

VALVE SEAT

Refacing

STEP 42

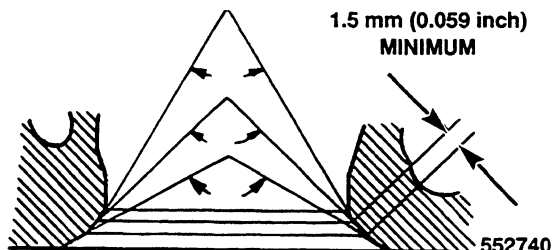

Use a valve seat cutting tool and make light cuts until the valve seat is within specifications. If the width of the valve seat is too wide, reduce the width with a 60° or 30° cutting tool. Apply engineers' blue to the valve and check for correct seat contact.

NOTE: Minimum valve seat contact width is 1.50 mm (0.059 inch).

STEP 43

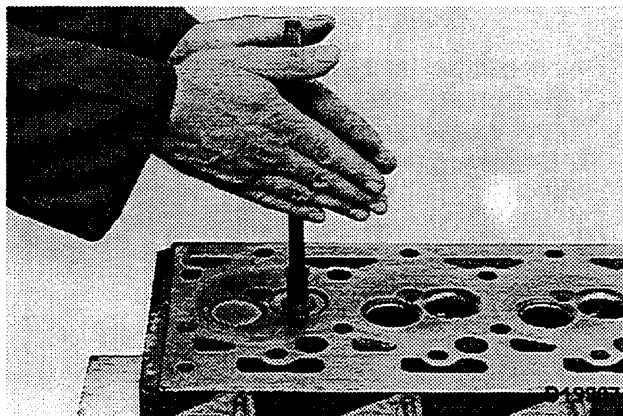

When the valve and seat contact are correct grind the valves and seats with grinding compound.

<https://www.ebooklibonline.com>

Hello dear friend!

Thank you very much for reading.

Enter the link into your browser.

The full manual is available for immediate download.

<https://www.ebooklibonline.com>