

1. Trim along dashed line.
2. Slide into pocket on Binder Spine.

TYPE 1-4

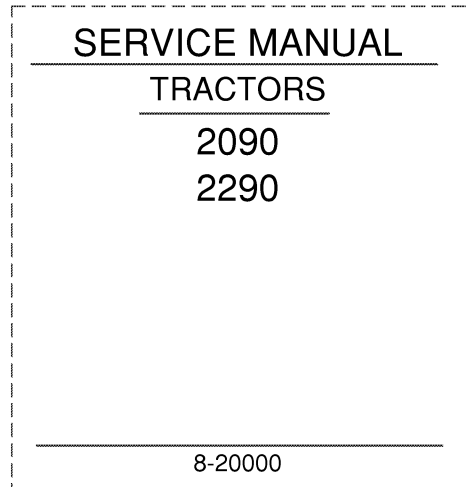

1. Trim along dashed line.
2. Slide into pocket on Binder Spine.

TYPE 1-4

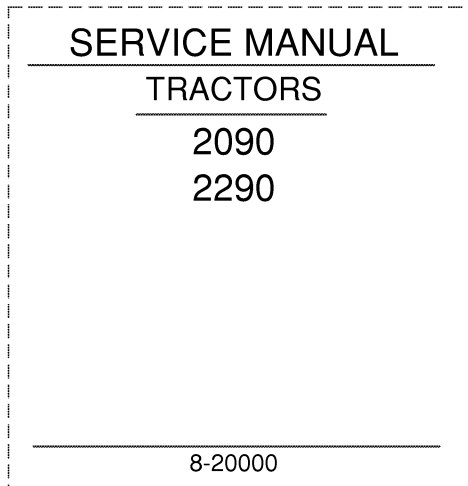

1. Trim along dashed line.
2. Slide into pocket on Binder Spine.

TYPE 1-4

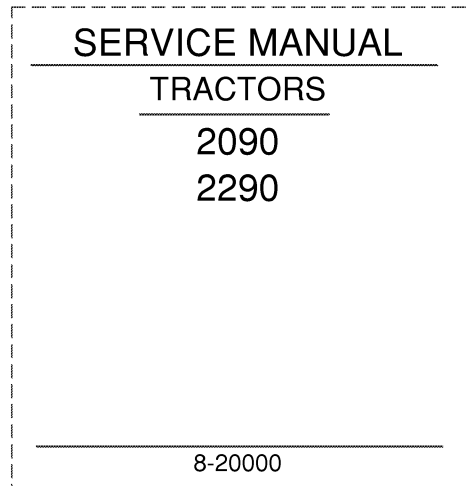

1. Trim along dashed line.
2. Slide into pocket on Binder Spine.

TYPE 1-4

# TABLE OF CONTENTS

## 2090 AND 2290 TRACTORS

SERIES	SECTION	DESCRIPTION	FORM NUMBER
10	<b>GENERAL</b>		
	1210	General Specifications - 2090 Tractors .....	8-20020
	1211	General Specifications - 2290 Tractors .....	8-20030
	1212	Lubrication - 2090 Tractors .....	8-20760
	1213	Lubrication - 2290 Tractors .....	8-20770
	1320	Engine Specifications 504BDT Engine .....	8-20040
	1420	Engine Specifications 504BD Engine .....	8-20050
	1230	Fuel System Specifications .....	8-20062
	1250	Steering Specifications .....	8-20070
	1260	Power Train Specifications .....	8-20080
	1270	Brake System Specifications .....	8-20090
	1280	Hydraulic System Specifications .....	8-20100
20	<b>ENGINES</b>		
	2201	Trouble Shooting - Engine .....	8-20111
	2202	Engine Tune-Up .....	8-20120
	2210	Tractor Split (Between Engine and Torque Tube) .....	8-20130
	2215	Cylinder Head, Valve Train and Camshaft .....	8-20140
	2225	Cylinder Block, Sleeves, Pistons and Rods .....	8-20150
	2235	Crankshaft, Main Bearing, Flywheel and Oil Seals .....	8-20160
	2245	Lubrication System - Oil Pump, Oil Pan and Heat Exchanger .....	8-20910
	2255	Cooling System .....	8-20180
	2265	Turbocharger - T04B .....	8-20190
	2565	Turbocharger Failure Analysis .....	9-78235
	2275	Air Induction System - 2290 Tractors .....	8-20210
	2375	Air Cleaner System - 2090 Tractors .....	8-20170
	2290	Reconditioning Engine Cylinder Block .....	8-21170
30	<b>FUEL SYSTEM</b>		
	3210	Fuel System and Filters .....	8-20220
	3212	Robert Bosch Fuel Injection Pumps .....	8-20230
	3213	American Bosch Fuel Injectors .....	8-20240
40	<b>ELECTRICAL</b>		
	4201	Electrical System Troubleshooting .....	8-22580
	4210	Tractor Electrical Wiring Diagram (Prior to P.I.N. 8841101) .....	8-20261
	4210	Tractor Electrical Wiring Diagram (P.I.N. 8841101 and After) .....	8-22640
	4220	Cab Electrical Wiring Diagram (Prior to Cab SN12008153) .....	8-20270
	4220	Cab Electrical Wiring Diagram (Cab SN12008153 and After) .....	8-22650
	4230	Starting Motors - Delco-Remy .....	8-21420
	4230	Starting Motors - Nippondenso .....	8-25980
	4235	Battery Servicing and Testing .....	8-20291
	4240	Delco-Remy Alternator System .....	8-21430
	4280	Neutral Start Switch Adjustment and Correct Starting Procedure Using Booster Batteries .....	8-20310
50	<b>STEERING</b>		
	5205	Testing Tractor Steering System .....	8-20330
	5210	Steering Column, Pump and Valve .....	8-20341
	5220	Steering Cylinder .....	8-20351
	5230	Front Steering Axle and Lines .....	8-20361

Reprinted

SERIES	SECTION	DESCRIPTION	FORM NUMBER	
60	<b>POWER TRAIN</b>			
	6201	Trouble Shooting - RPS-34 Power Shift Transmission and PTO .....	8-20370	
	6205	Testing RPS-34 Power Shift Transmission and PTO .....	8-20380	
	6225	Hydraulic Pump Drive .....	8-24820	
	6245	Hydraulic PTO - 540 and 1000 RPM .....	8-20411	
	6345	Hydraulic PTO - 1000 RPM .....	8-21291	
	6250	Rear Axles and Planetaries .....	8-20420	
	6255	Differential and Differential Lock .....	8-20430	
	<b>Mechanical Shift Tractors</b>			
	6310	Tractor Split (Between Torque Tube and Transmission) .....	8-20390	
	6320	Master Hydraulic Clutch .....	8-20440	
	6330	Hi-Lo and Reverse Range .....	8-20451	
	6335	Master Clutch Valve and Linkage .....	8-20460	
	6340	Four Speed Transmission .....	8-20470	
	<b>Power Shift Tractors</b>			
	6420	Torque Limiter Clutch .....	8-20481	
	6430	RPS-34 Power Shift .....	8-20490	
	6435	RPS-34 Control Valve and Linkage .....	8-20500	
	6440	Four Speed Transmission .....	8-20510	
	70	<b>BRAKES</b>		
		7210	Power Assist Unit and Pedals .....	8-20520
7215		Park Lock System .....	8-20531	
	7220	Brake Cylinders .....	8-20540	
80	<b>HYDRAULIC</b>			
	8202	Trouble Shooting - Hitch System .....	8-20560	
	8205	Testing Tractor Hydraulic System .....	8-20571	
	8210	Hydraulic Oil Filters .....	8-20581	
	8220	Hydraulic Charging Pump .....	8-20591	
	8225	Hydraulic Pump .....	8-20601	
	8250	Remote Hydraulic Valves .....	8-20610	
	8255	Flow Divider and PTO Control Valve .....	8-20620	
	8280	Hitch System .....	8-20631	
	8290	Break-Away Couplings and Portable Cylinders .....	8-20640	
	90	<b>ACCESSORIES</b>		
9205		Trouble Shooting - Air Conditioning System .....	8-20650	
9215		Gauging and Testing Air Conditioning System .....	8-20660	
9225		Compressor Isolation, Removal, Installation and Evacuation - Discharging, Evacuation and Charging the Air Conditioning System .....	8-20670	
9235		Servicing Air Conditioner Components .....	8-20680	
9245		Servicing the Cab Blower .....	8-20690	
9250		Operators Seat Adjustments .....	8-20700	
9260		Removal of Tilting Hood, Grill and Side Panels .....	8-20710	
9360		Removal of Sliding Hood, Grille and Side Panels .....	8-20720	
100		<b>HOW IT WORKS</b>		
	18201	Tractor Hydraulics System Oil Flows .....	8-21330	
	18225	Case CON TROL Hydraulics .....	8-21350	

**<https://www.ebooklibonline.com>**

Hello dear friend!

Thank you very much for reading.

Enter the link into your browser.

The full manual is available for immediate download.

**<https://www.ebooklibonline.com>**

# Section 1210

## GENERAL SPECIFICATIONS

### 2090 Tractors

Written In *Clear  
And  
Simple  
English*

## SERIAL NUMBERS

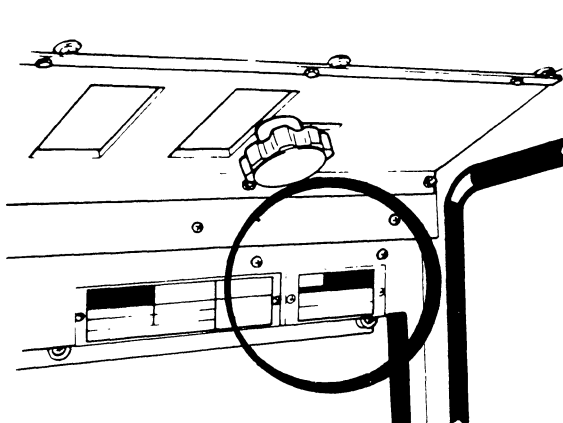

**MODEL AND PRODUCT IDENTIFICATION  
NUMBER PLATE**

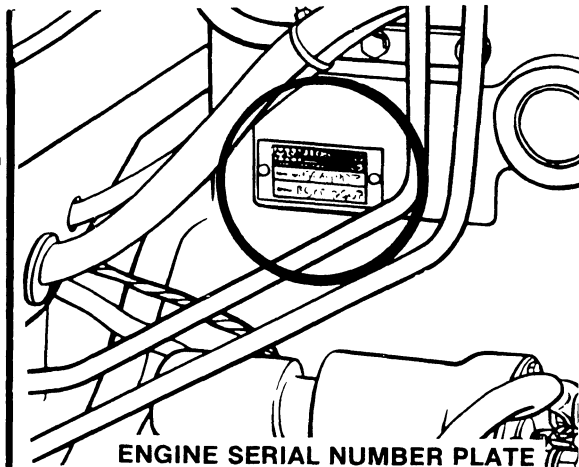

**ENGINE SERIAL NUMBER PLATE**

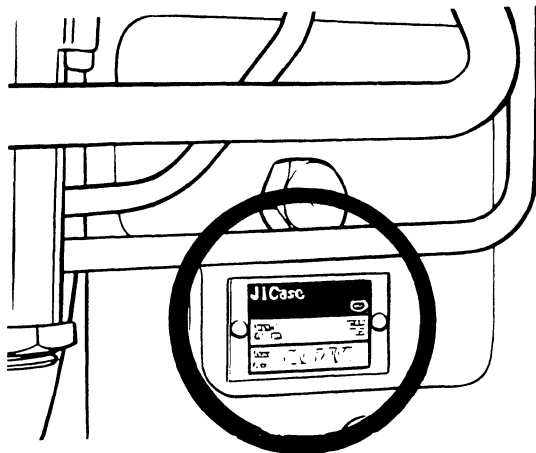

**TRANSMISSION SERIAL NUMBER PLATE**

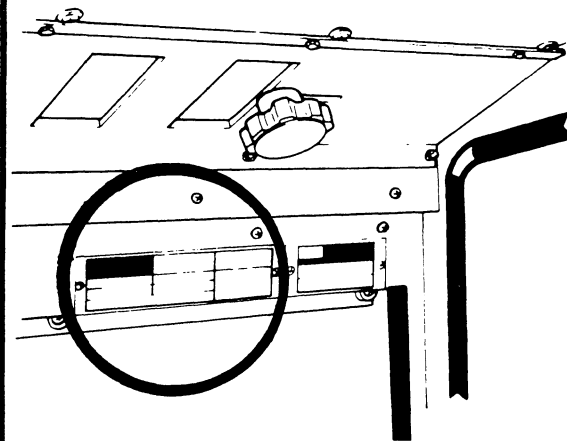

**CAB SERIAL NUMBER PLATE**

## DIESEL ENGINE SPECIFICATIONS

### General

Type .....	Six Cylinder, Four Stroke Cycle, Natural Aspirated, Valve in Cylinder Head
Firing Order .....	1-5-3-6-2-4
Bore .....	4-5/8 Inches (117.5 mm)
Stroke .....	5 Inches (127 mm)
Piston Displacement .....	504 Cubic Inches (8 259 cm <sup>3</sup> )
Compression Ratio .....	16.0 to 1
Cylinder Sleeves .....	Wet Type, Can be Removed
Governor Engine Speed Without Load .....	2280 to 2320 RPM
Rated Engine Speed .....	2100 RPM
Engine Idle Speed .....	725 to 775 RPM
Rocker Arm-to-Valve Clearance (Exhaust) .....	0.025 inch (0.635 mm)
(Intake) .....	0.015 inch (0.381 mm)

**IMPORTANT:** *Rocker Arm-to-valve clearance adjustments must be made when the engine is not running.*

### Piston and Rod

Rings Per Piston .....	3
Compression Rings Per Piston .....	2
Oil Rings Per Piston .....	1
Type Piston Pin .....	Full Float
Type Bearings .....	Replacement Bearings Available, Steel Back with Aluminum or Copper and Lead Liners.

### Main Bearings

Quantity of Bearings .....	7
Type of Bearings .....	Replacement Bearings Available. Steel Back with Aluminum or Copper and Lead Liners.

## Engine Lubrication System

Oil Pressure .....	45 to 60 PSI (310 to 414 kPa)(3.1 to 4.14 bar) with Engine Warm and Operating at Rated Speed.
Type System .....	Pressure and Spray
Oil Pump .....	Gear Type
Oil Filter .....	Full Flow, Turn on Type, By-pass Valve in Filter Base.
Oil Capacity .....	With Filter, 19 U.S. Qts. (17.8 litres) Without Filter, 18 U.S. Qts. (17.0 litres)

## Fuel System

Fuel Injection Pump .....	Robert Bosch, Type PES
Pump Timing .....	27 Degrees (BTDC) Before Top Dead Center. <b>IMPORTANT:</b> <i>Do not increase past 27 degrees BTDC at any time. The given 27 Degrees Gives Minimum Emissions in Tractor Operation.</i>
Fuel Injectors .....	American Bosch, 17mm
Fuel Transport Pump .....	Plunger Type, a Part of the Fuel Injection Pump.
Governor .....	Variable Speed, Parts of Fuel Injection Pump
First Stage Fuel Filter .....	Full Flow, Turn on Type
Second Stage Fuel Filter .....	Full Flow, Turn on Type
Water Trap and Drain for Fuel Tank .....	Location is in Bottom of Fuel Tank
Fuel Tank Capacity .....	65 U.S. Gallons (246 litres)
Fuel Level Gauge .....	Electric, Location is on Instrument Cluster.
Hand Primer Pump .....	Location is on Top of Fuel Transport Pump
Primary Fuel Filter .....	Location is at Bottom of Fuel Transport Pump



## Electrical System

### Bulb and Lamp Replacement:

Instrument Cluster Warning Bulbs .....	No. 168
Instrument Cluster Illumination Bulbs .....	No. 194
Dome Light Bulb .....	No. 93
Console Light Bulb .....	No. 194
Flasher Light Bulbs .....	No. 1156
Headlight Lamps .....	No. 4652
Front and Rear Flood Lights .....	No. H7606
Tail Light Bulbs .....	No. 168

### Fuse and Circuit Breaker Replacement:

Headlight High Beam .....	20 Ampere
Headlight Low Beam .....	15 Ampere
Tail Light .....	15 Ampere
Instrument Panel Lights .....	5.0 Ampere
Key Switch .....	15 Ampere
Front Flood Lights (Optional) .....	15 Ampere
Rear Flood Lights (Optional) .....	20 Ampere
Front and Rear Flood Lights (Relay-Optional) .....	30 Ampere
Console Light .....	1.0 Ampere
Dome Light .....	1.0 Ampere
Cigarette Lighter .....	15 Ampere
Blower .....	15 Ampere
Wipers .....	6.0 Ampere

## Tractor Brakes

Type ..... Hydraulic, Power Assistance, Self-Adjusting,  
Several Plate Wet Type Differential Brakes.

## Power Shift Transmission

Type ..... Three Speed, Power Shift, Compound Planetary with Hydraulically Actuated  
Clutches and a Four Speed Gear Section.

Gear Selection ..... 12 Speeds Forward and Three Speeds Reverse

Shift Control ..... Hydraulic Power Shift Controlled by a Mechanical  
Shifter actuated by levers on the console.

Oil Cooler ..... Transmission, Hydraulic, Steering and Brake Oil

## Mechanical Transmission (If Equipped)

Type ..... Two Speed Range Gear with a Four Speed Gear Section

Gear Selection ..... Eight Speeds Forward and Four Speeds Reverse

Shift Control ..... Mechanical Shifter Actuated by levers on the console

## Park Lock System

Parking Lock ..... Actuated by Gear Shift Lever

## Differential Lock

Type ..... Hydraulically Actuated by Foot Pedal

## Hydrostatic Power Steering

Type ..... Gear Pump Part of Hydraulic Pump

Pump Capacity at 2100 Engine RPM ..... 8 GPM (30.3 l/min)

Steering Pump ..... Hydrostatic Type, Actuated by the Steering Wheel

Steering Cylinder ..... Double Action Cylinder

## Hitch System

Type of Sensing ..... Lower Link

Type Control ..... Hand Lever

Type Valve ..... Three Position - Lift, Hold and Lower

Type Draft Arms ..... Rigid, Swing Type with Manual Float Adjuster

Type Hitch ..... Three Point, Category II

Conversion Hitch Coupler (Available) ..... Category II to III

## Remote Hydraulic System

Pump ..... Axial Piston Pump, Pressure and Flow Compensated.

Type Remote Valve ..... Closed Center, One to Four Sections, Hand Lever Control,  
Variable Flow Control for Each Section.

Pump Capacity at 2100 Engine RPM ..... 24 to 26 GPM (90.9 to 98.4 l/min)

Max System Pressure ..... 2250 PSI (15 503 kPa) (155.03 bar)

Couplings ..... ASAE R366 Standard, Fast Removal, Break Away Type

## Power Takeoff

Type Clutch ..... Hydraulic Actuated

Rotation ..... Clockwise

Spline Size ..... 1000 RPM, 21 Splines, 1-3/8 Inch (34.9 mm) Diameter

Spline Size Two Size Conversion Optional ..... 540 RPM, 6 Splines, 1-3/8 Inch (34.9 mm) diameter, 1000 RPM,  
21 Splines, 1-3/8 Inch (34.9 mm) Diameter

Engine Speed 2100 RPM ..... 540 or 1000 RPM Shaft Speed

## Drawbar

Standard or Yoke Type ..... Slide type, Takes a 1-1/4 Inch (31.75 mm) Diameter Pin.

## LOW ENGINE OIL PRESSURE (Continued)

### INTERNAL PROBLEMS (Continued)

#### 14. Piston Ring Installation Not Correct Or Broken Rings.

The following errors are made when installing rings:

- A. the wrong size rings are used.
- B. the wrong side of the ring is facing up.
- C. the butt ends of the expander in the three piece oil control ring go over each other or the expander is cut to shorten the expander.

Read the instructions carefully before installing the piston rings. Damage to the rings can cause scoring of the pistons and sleeves and can cause the engine to use oil.

#### 15. Damage To The Turbocharger Seal.

A leakage past the seal or a failure in the turbocharger will let the lubrication oil go in to the intake manifold and be burned in the engine. Check the compressor and the turbine wheel for signs of lubrication oil.

# INSTALLATION INSTRUCTIONS FOR M20614 TEFLON VALVE SEAL KIT

## Special Tools Required

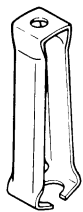

M20624 SEAL INSTALLATION TOOL



M20617 VALVE GUIDE CUTTING TOOL

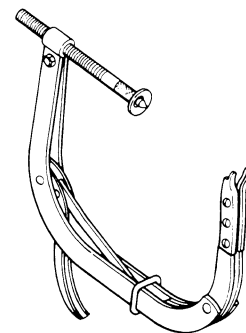

VALVE SPRING COMPRESSOR

### STEP 1

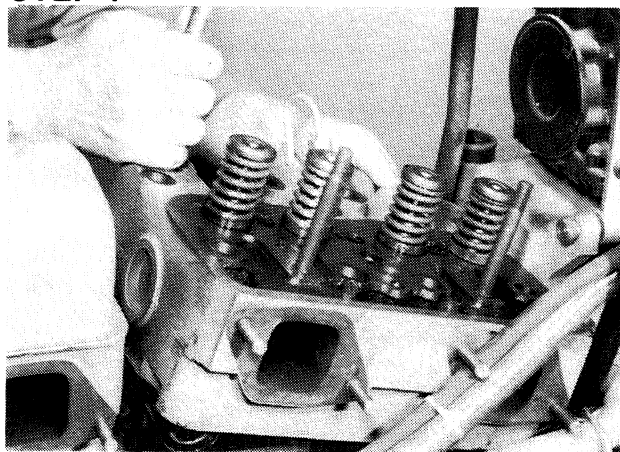

Remove the cylinder heads. See Section 2215 of the Service Manual for removal of the cylinder heads.

### STEP 2

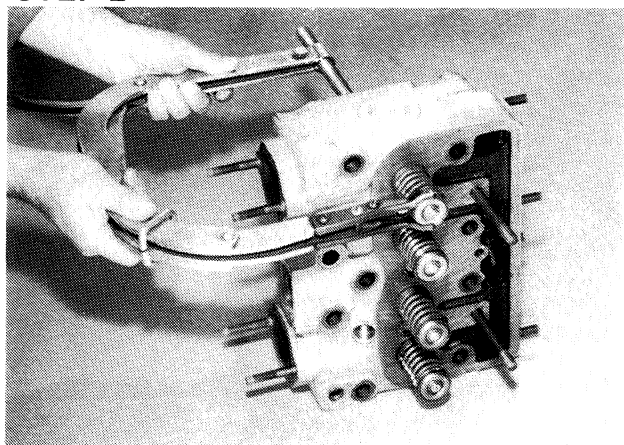

Use a valve spring compressor to push down the valve springs.

**IMPORTANT:** Make a mark on the valves, rotators, spring retainers and keepers. This will make sure that the parts are installed in the original location.

### STEP 3

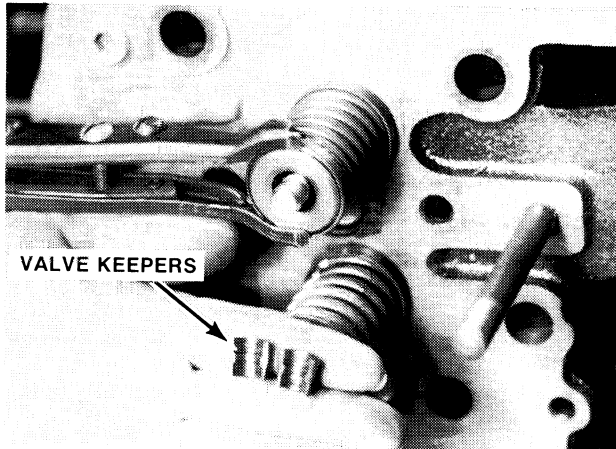

Push down the valve springs and remove the valve keepers.

### STEP 4

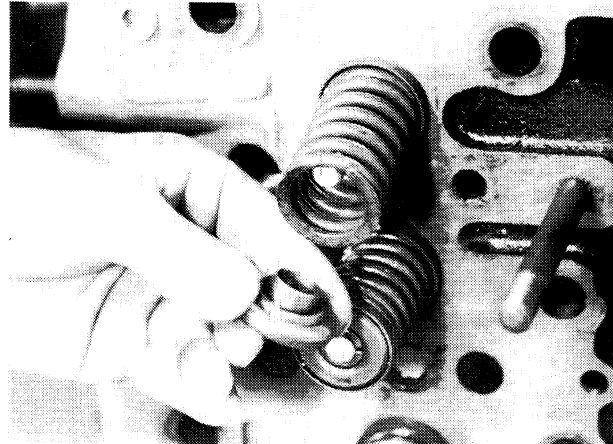

Remove the valve rotators or the valve spring retainers.

**STEP 5**

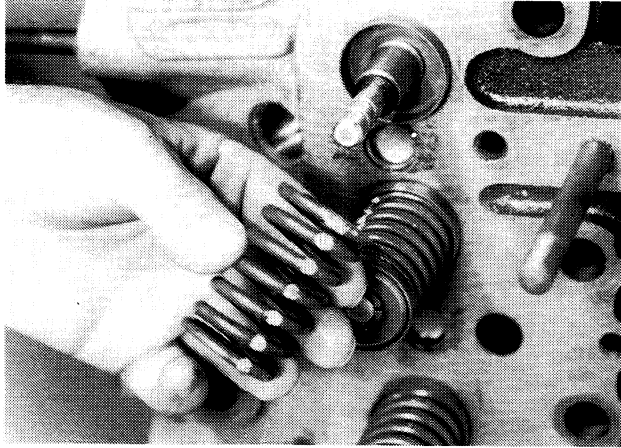

Remove the valve springs.

**STEP 8**

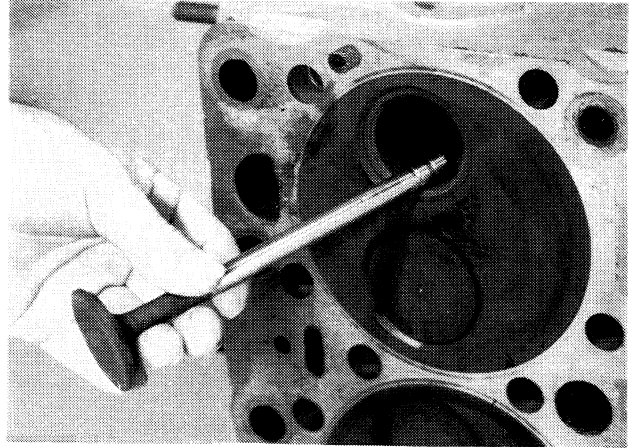

Remove the valves.

**STEP 6**

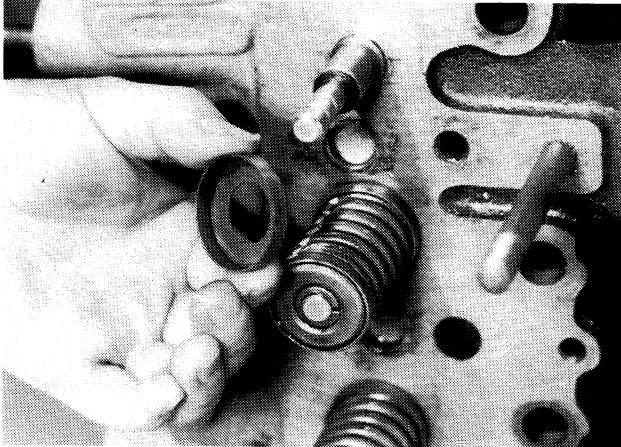

Remove the spring seats.

**STEP 9**

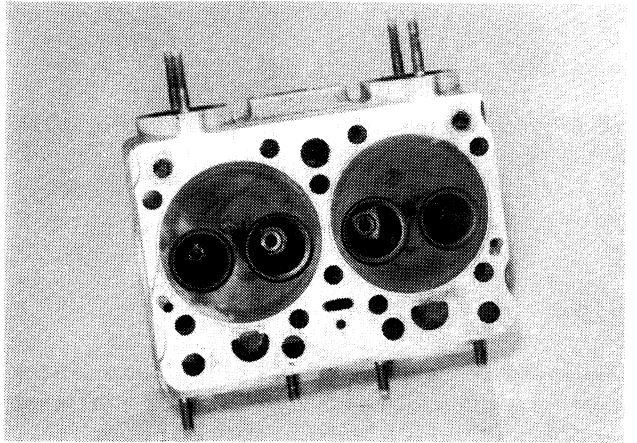

Clean the cylinder head completely, removing all the carbon and other deposits. Check for cracks and for any sign of damage, existing in the area of the fire ring contact.

**STEP 7**

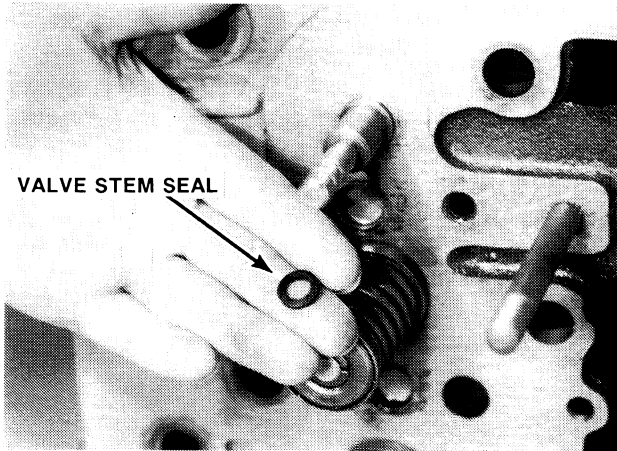

Remove the valve stem seals.

**STEP 10**



Clean the valves with a fine wire brush that is power driven. Remove all carbon and varnish deposits. Do not scratch the valve stems.

### STEP 11

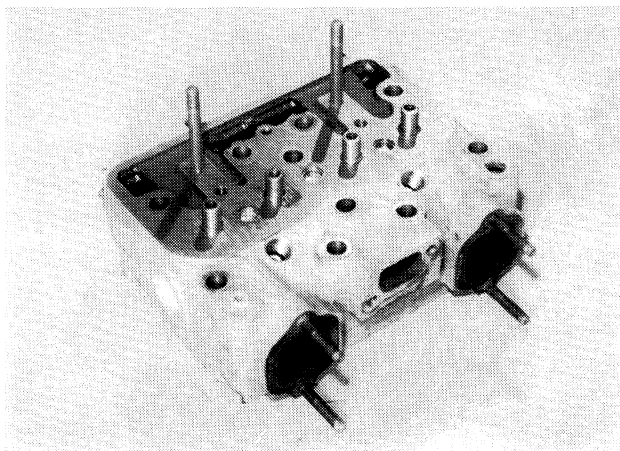
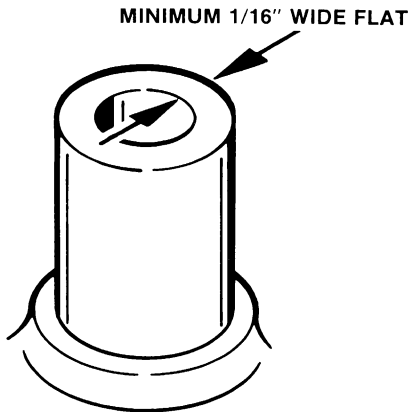

Check the top surface of the valve guide. There must be a minimum of a 1/16" (0.0625 mm) wide flat around the complete top surface.

### STEP 12

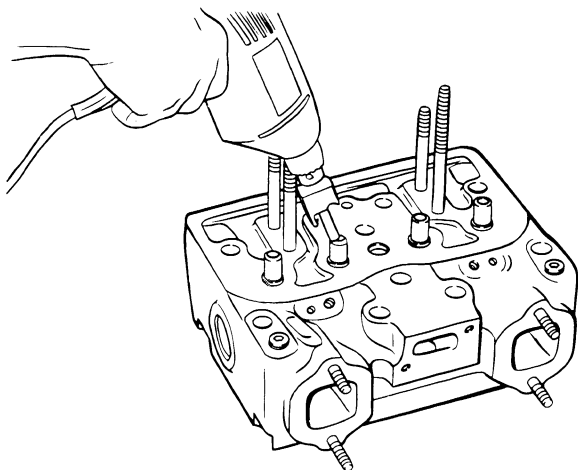

Use the M20617 tool in an electric drill to give the necessary flat area on the valve guide.

**IMPORTANT:** Do not go over 450 RPM when drilling.

### STEP 13

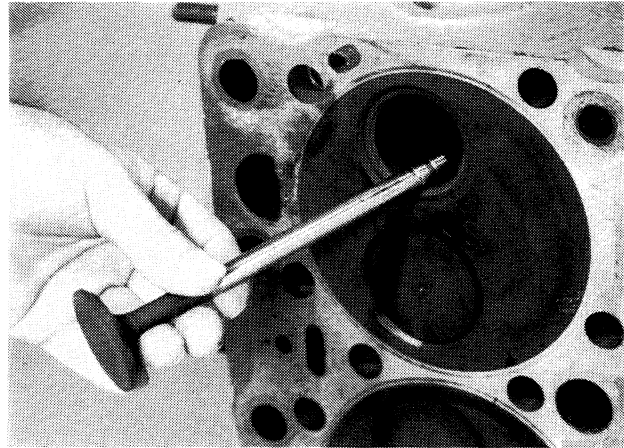

Put clean engine oil on the valves before installing the valves in the cylinder head.

### STEP 14

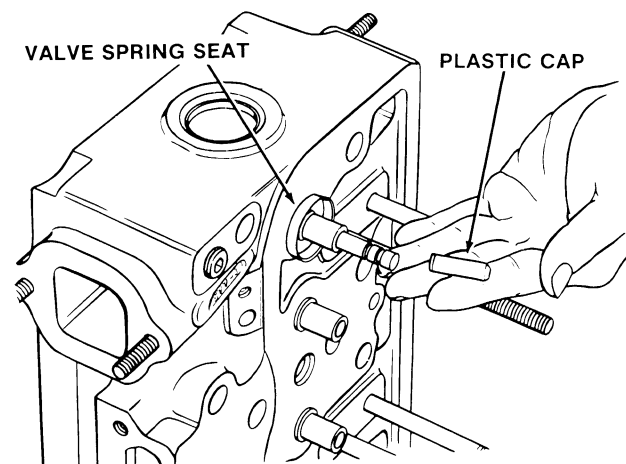

Install the spring seats. Put the plastic installation cap on the end of the valve stem. The plastic cap prevents the sharp edges on the valve stem grooves from cutting the valve seal.

**NOTE:** One M20614 kit is required for one cylinder head.

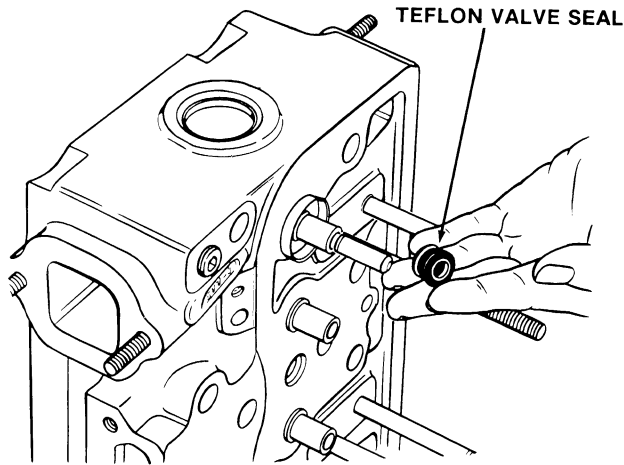
**STEP 15**

Put the valve seal over the plastic cap. Hold your thumb against the white seal insert to keep the insert from coming out. Push the valve seal down so that the seal jacket is against the top of the valve guide. Remove the installation cap. Keep the cap since the cap will be used again.

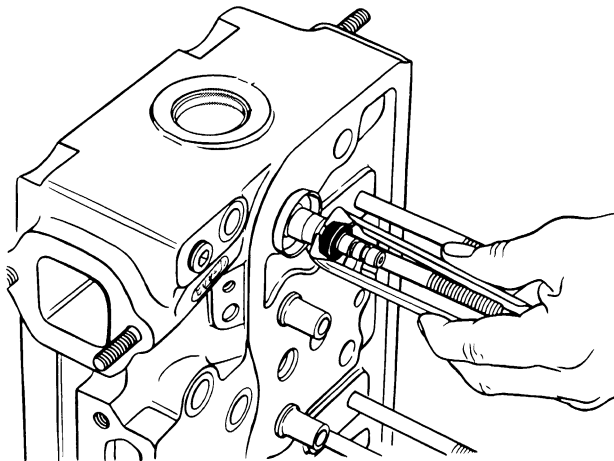
**STEP 16**

Use the M20624 tool and push the seal down over the valve guide until the seal is level with the top of the guide.

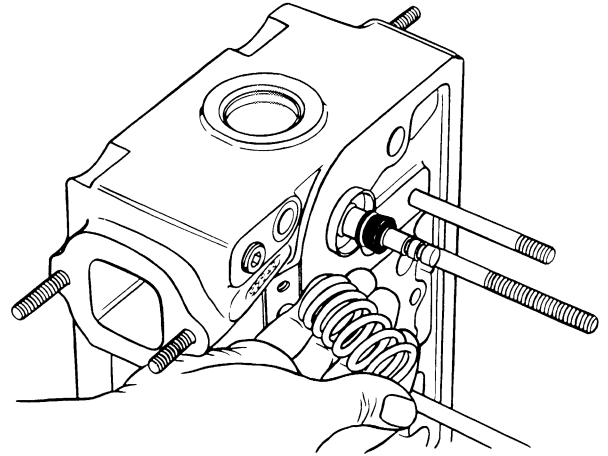
**STEP 17**

Install the valve spring. Either end of the valve spring can be installed in the valve spring seat because both ends of the spring are closed.

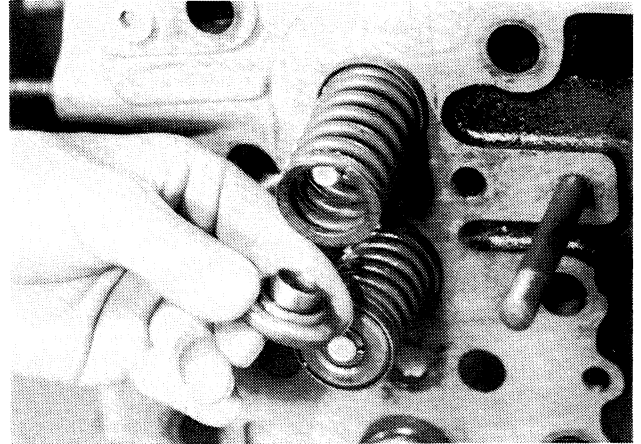
**STEP 18**

Install the valve rotators or the valve spring retainers (flat side up).

**IMPORTANT:** *Install the valve rotators or the valve spring retainers with the original valves because these parts are worn as counterparts of each other.*

**STEP 19**

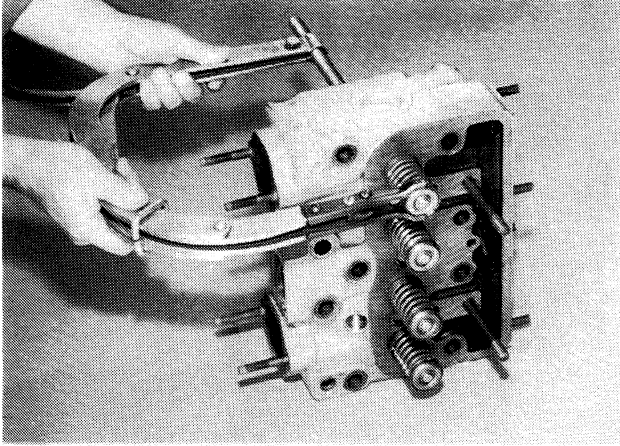

Push down the valve springs with a spring compressor.

**STEP 22**

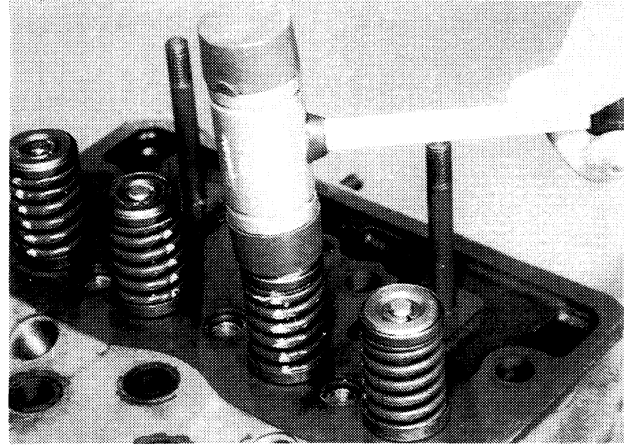

Remove the spring compressor. Hit the end of the valve stems with a soft hammer to seat the valve keepers.

**STEP 20**

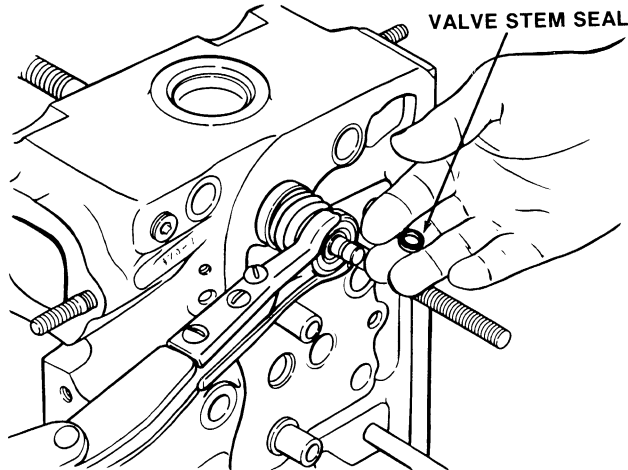

Install a new valve seal in the lower valve stem groove.

**STEP 23**

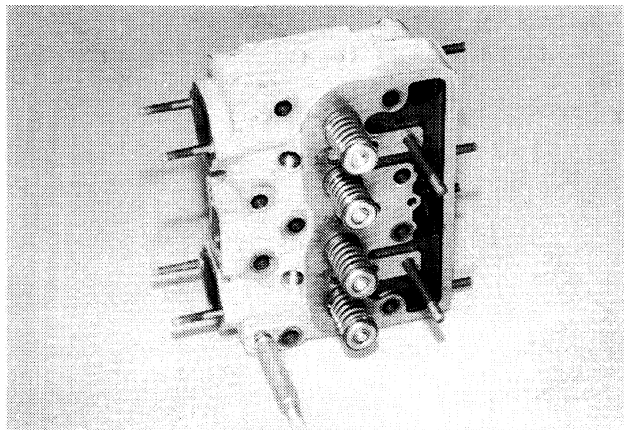

Install teflon seals on all the intake and exhaust valves.

**STEP 21**

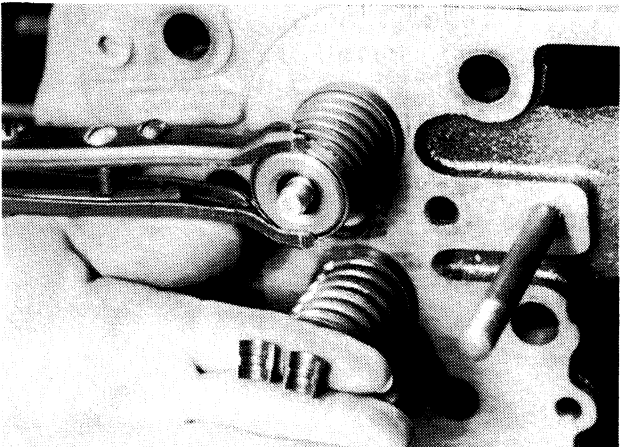

Install the valve keepers in the upper valve stem groove.

**STEP 24**

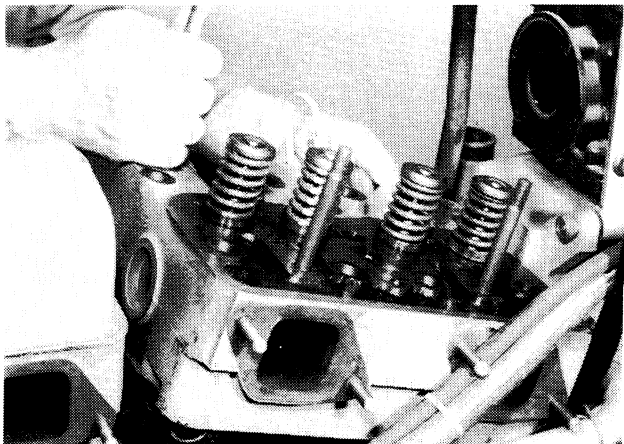

Install the cylinder heads. See Section 2215 of the Service Manual for installation of the cylinder heads.

## ENGINE TUNE-UP PROCEDURE

### Checking The Crankshaft Damper Pulley (If Equipped)

#### STEP 1

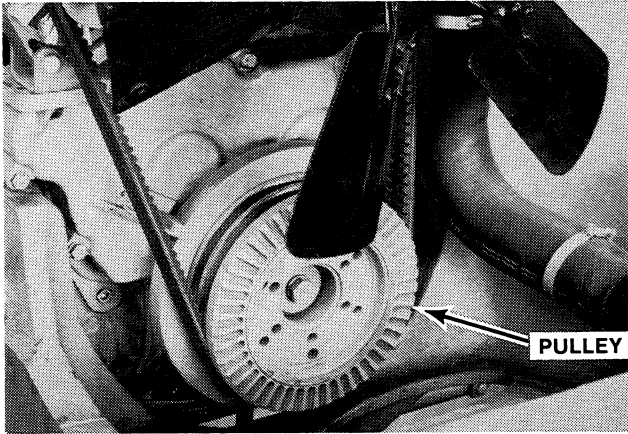

The recommendation for the change interval for the crankshaft damper pulley is 2000 hours maximum. At any time over 1500 hours change the pulley at any engine overhaul or tune-up.

Every 500 hours and during the engine tune-up, visually check the rubber element for areas where the rubber is coming off or cracked. Check the alignment of the marks between the inner and outer units. If the marks move, the damper pulley must be replaced. Go to Step 2 for pulley removal.

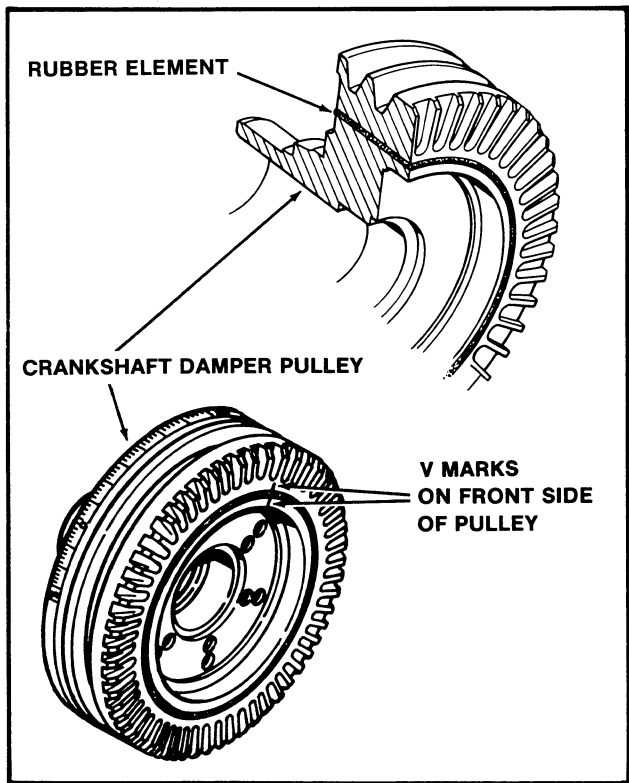

#### STEP 2

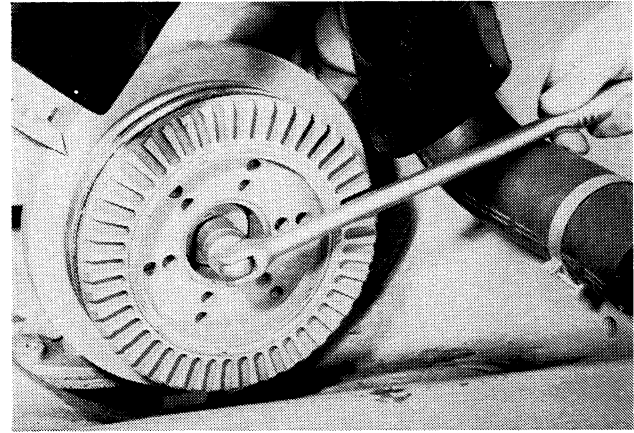

Loosen the pulley to crankshaft bolt.

**NOTE:** See Section 9260 or 9360 of the Service Manual for hood removal and Section 2255 for radiator and alternator belts removal.

#### STEP 3

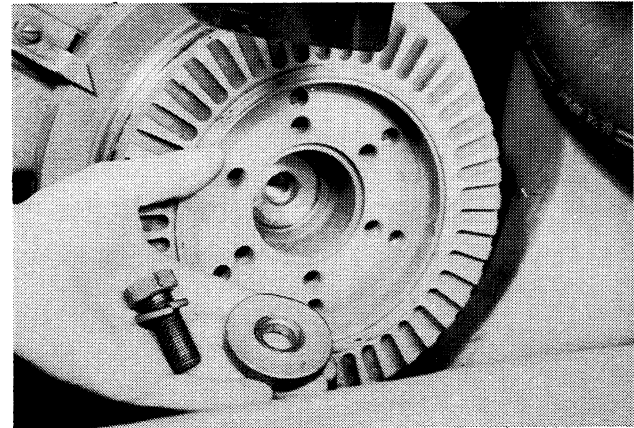

Remove the bolt, lockwasher and the retainer washer.

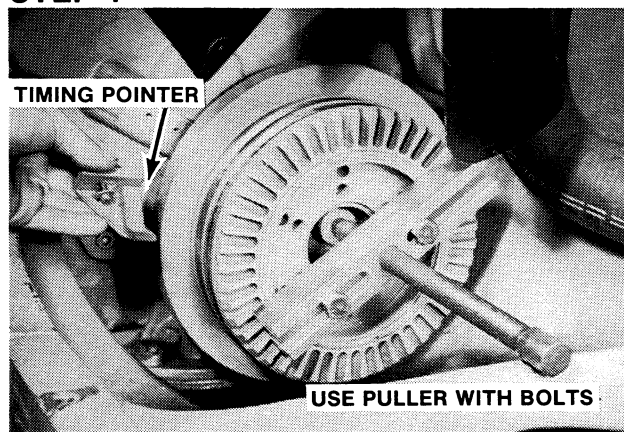
**STEP 4**

Remove the timing pointer.

**IMPORTANT:** Use a puller with bolts to remove the pulley. Do not pull or hit the pulley or the viscous damper. Serious damage to the pulley, damper and the rubber sleeve in the pulley can result.

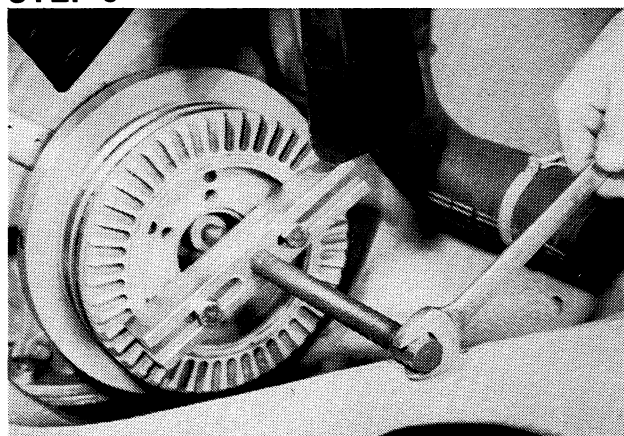
**STEP 5**

Remove the pulley.

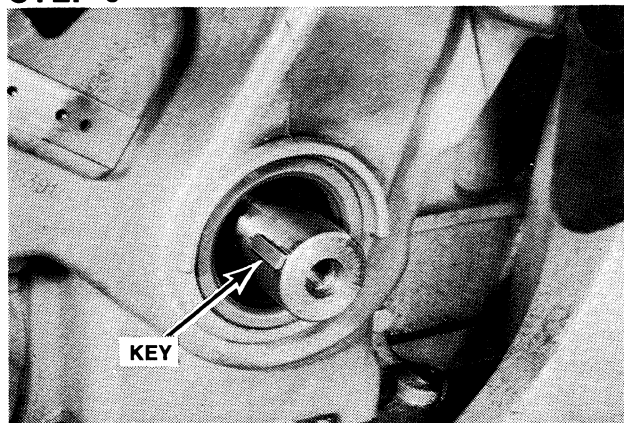
**STEP 6**

Do not lose the pulley retaining key.

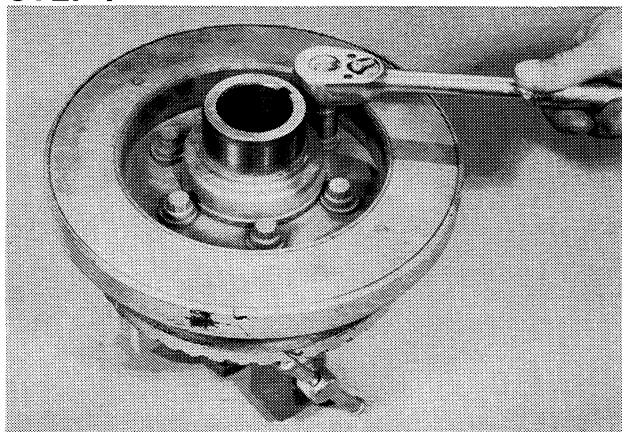
**STEP 7**

Leave the puller on the pulley and put the puller in a vise. Loosen the bolts that hold the damper (if equipped) to the pulley.

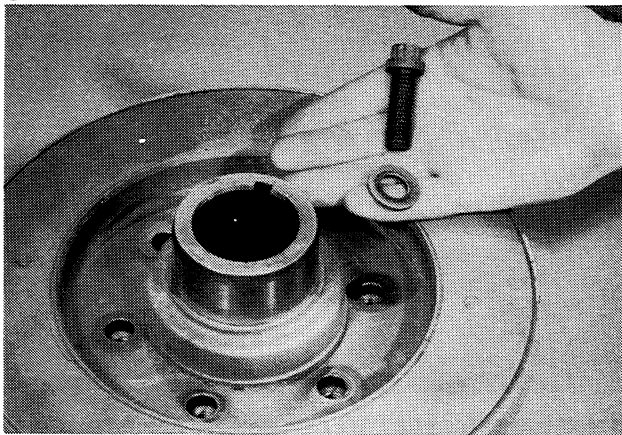
**STEP 8**

Remove the bolts and the washers.

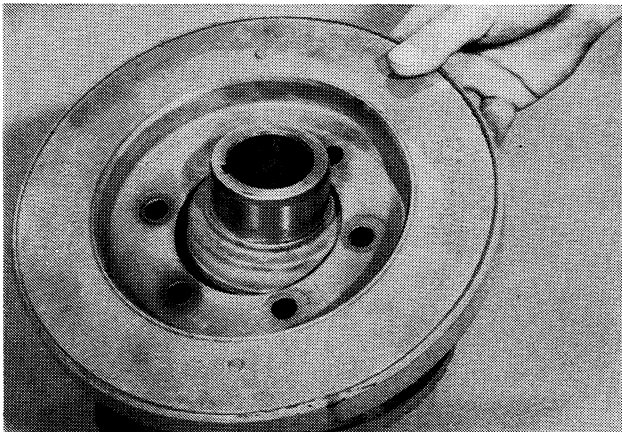
**STEP 9**

Remove the damper.

**STEP 10**

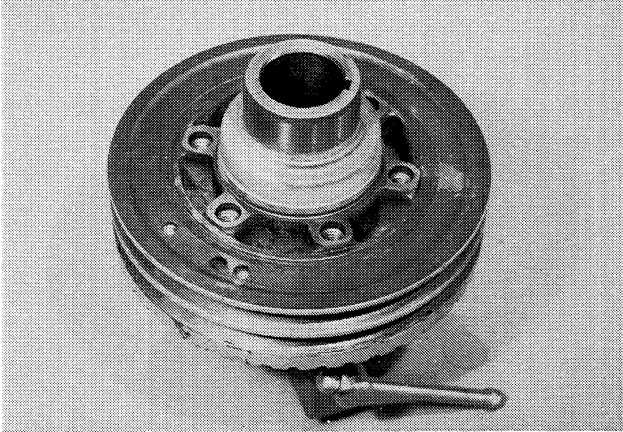

Fasten the puller to the front side of a new pulley and put the puller in a vise.

**STEP 13**

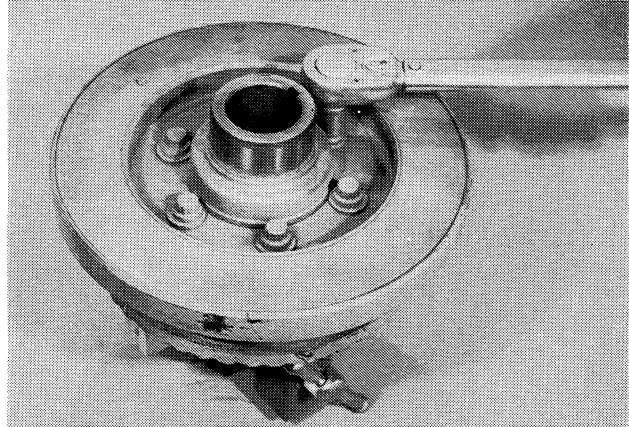

Tighten the bolts to a torque of 110 to 132 ft. lbs. (149 to 179 Nm)(14.9 to 17.9 kgm). Remove the puller.

**STEP 11**

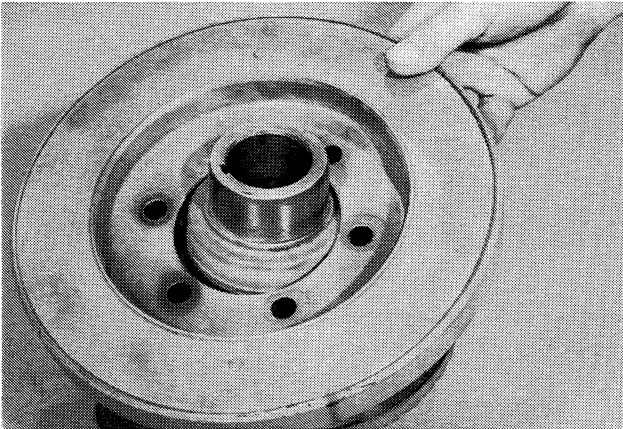

Install the damper to the pulley. The flat side of the damper is against the pulley.

**STEP 14**

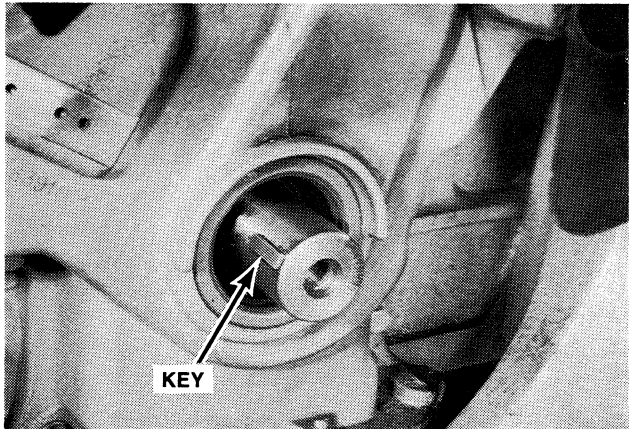

Replace the key if the key shows damage.

**STEP 12**

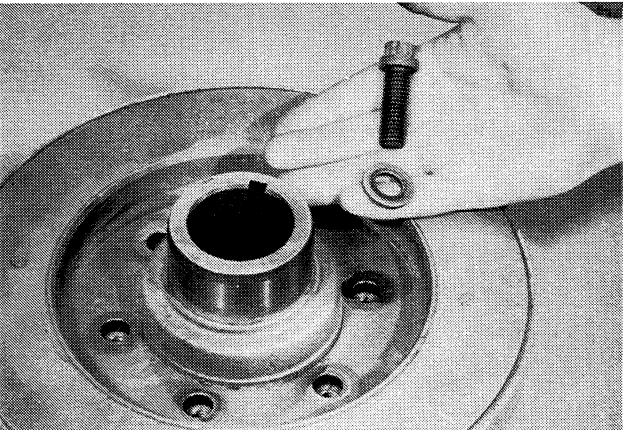

Install the bolts and new hardened washers.

**STEP 15**

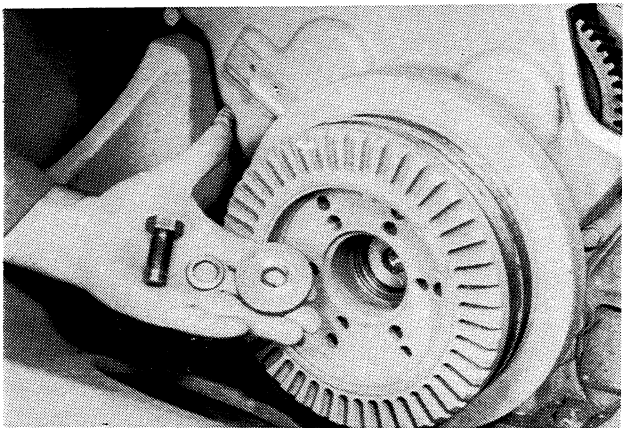

Install the pulley to the crankshaft. Install the bolt, lockwasher and retaining washer.

**NOTE:** The hub side of the pulley must be put against the engine. Align the crankshaft key with the slot in the pulley.

**STEP 16**

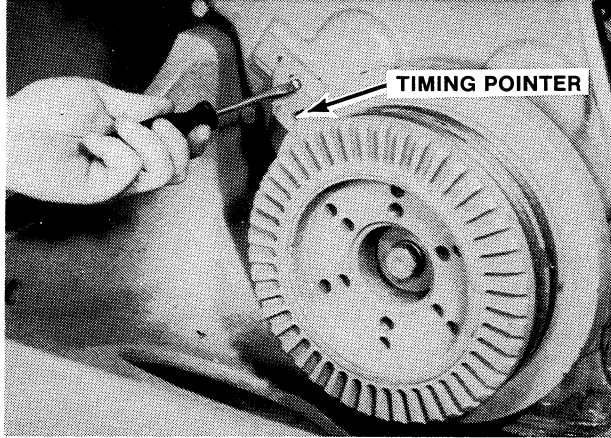

Install the timing pointer.

**STEP 17**

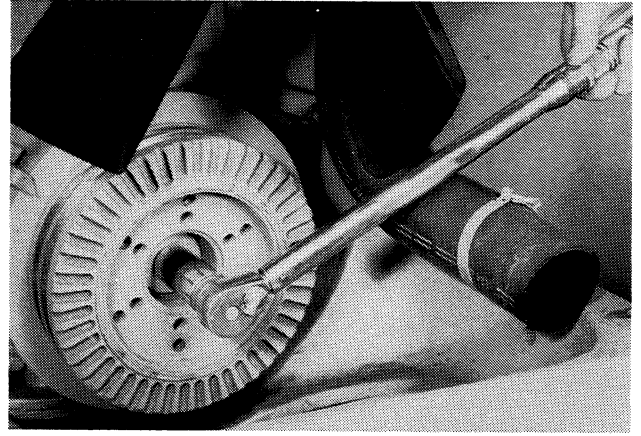

Tighten the bolt to a torque of 100 to 110 ft. lbs. (136 to 149 Nm)(13.6 to 14.9 kgm).

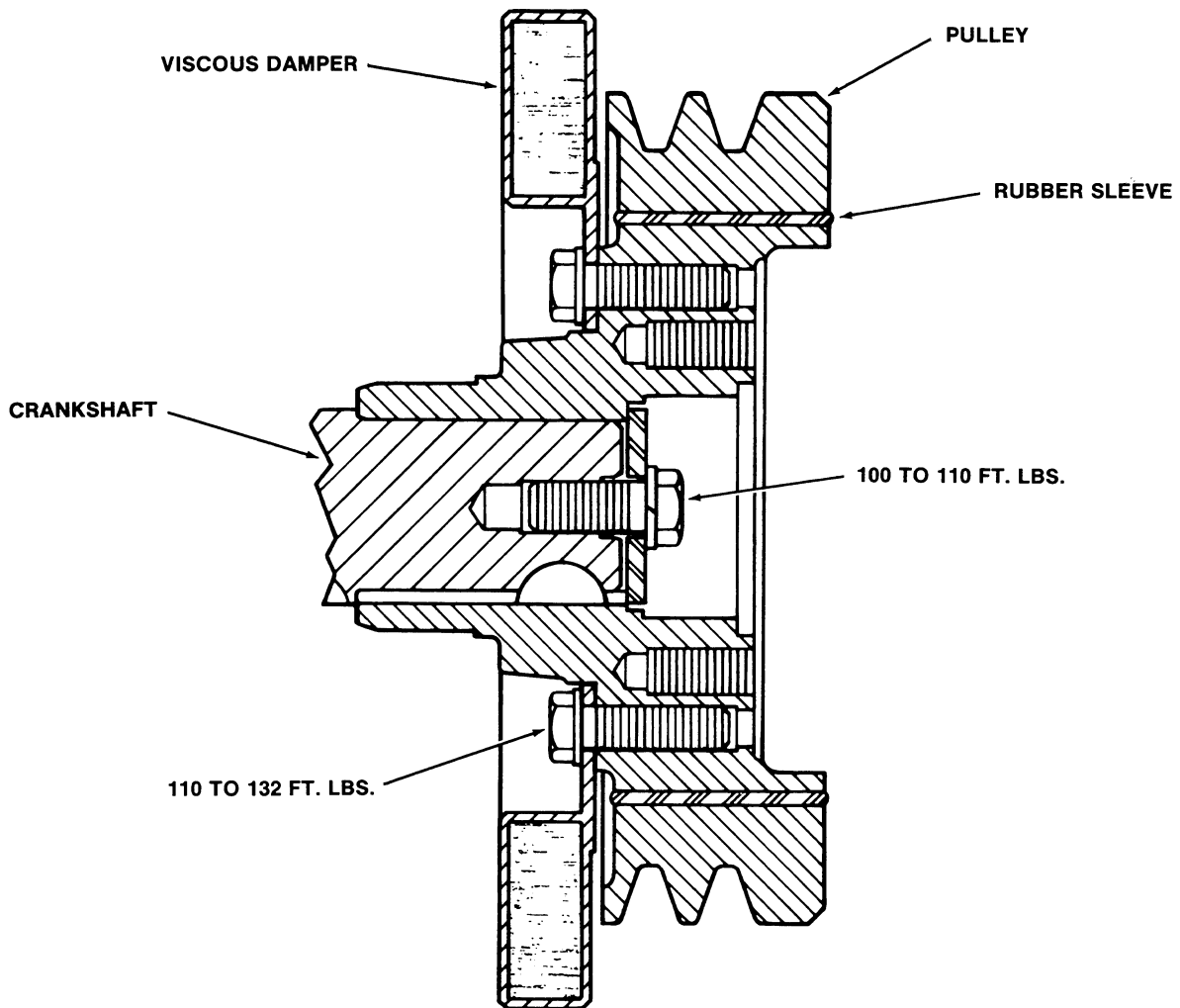

## Checking Top Dead Center

**IMPORTANT:** Before checking top dead center, check the alignment marks on the pulley, see Step 1.

### STEP 18

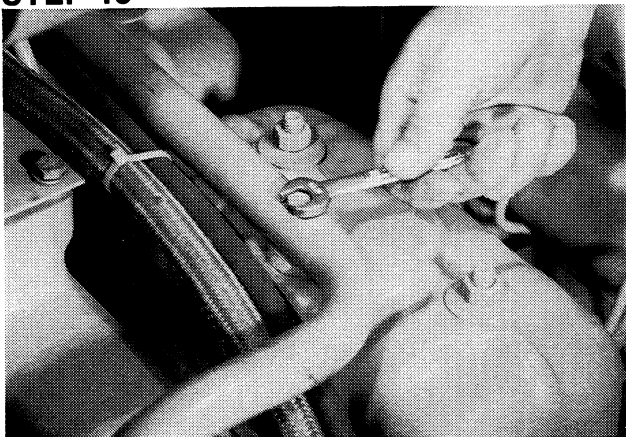

Remove the breather tube.

### STEP 19

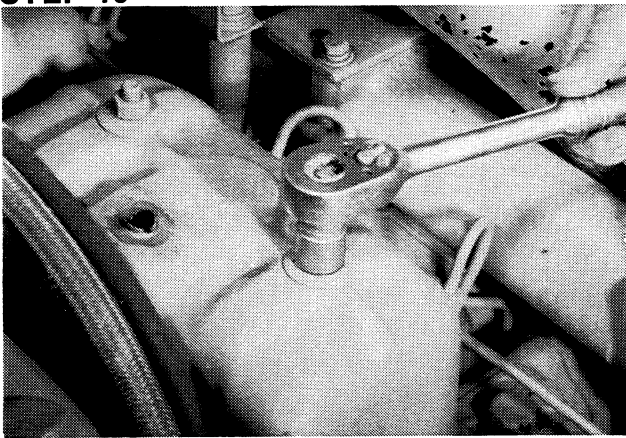

Remove the nuts, washers and rubber gaskets from the front valve cover.

### STEP 20

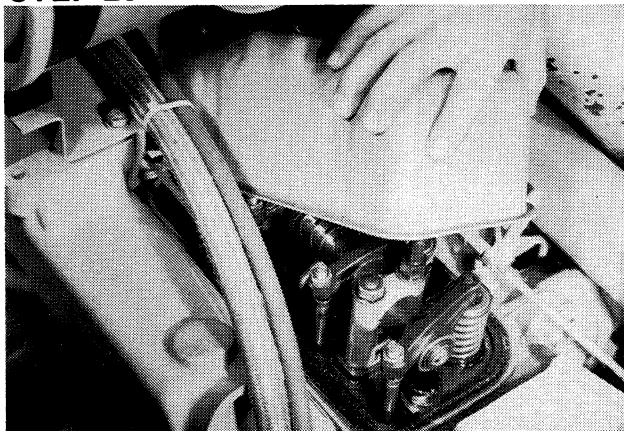

Remove the front valve cover.

### STEP 21

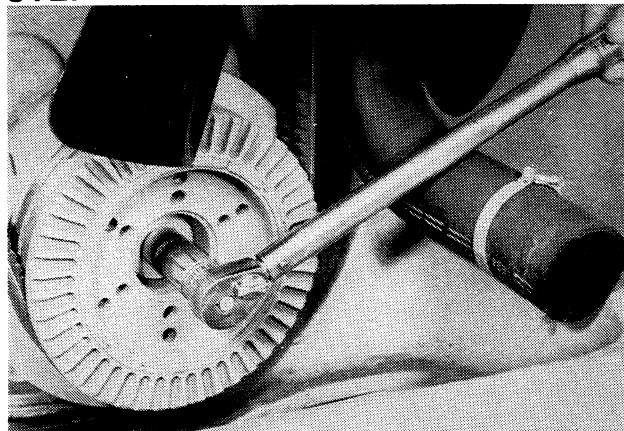

Turn the engine over until the Top Dead Center mark on the crankshaft pulley is aligned with the timing pointer.

**STEP 22**

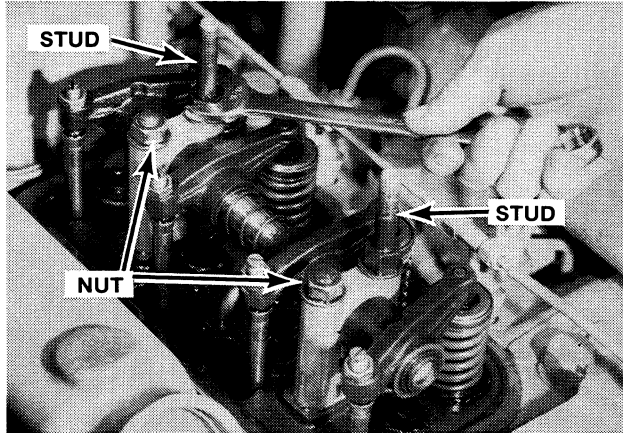

Remove the rocker arm retaining studs, nuts and washers.

**STEP 23**

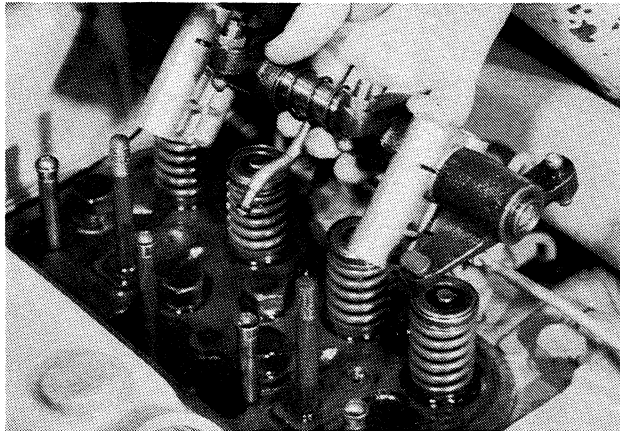

Remove the rocker arm assembly.

**STEP 24**

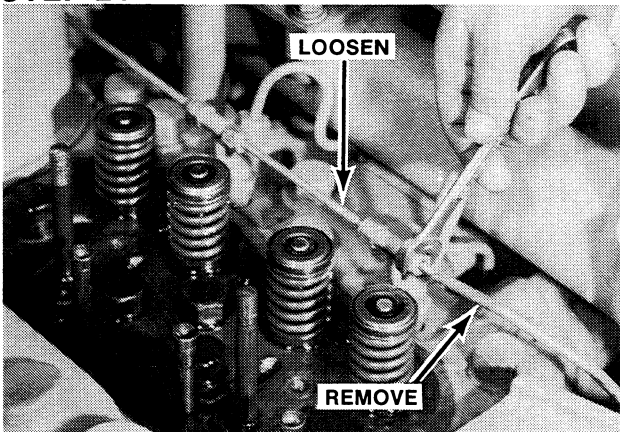

Remove the leak off line from the Number One fuel injection nozzle to the fuel pump. Loosen the leak off line between the Number One and the Number Two fuel injection nozzles.

**NOTE:** Removal of fuel lines will prevent damage to the lines when removing the exhaust valve spring.

**STEP 25**

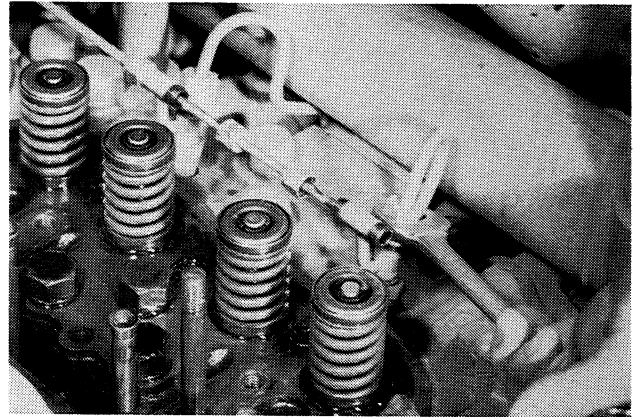

Loosen the Number One nozzle fuel line.

**STEP 26**

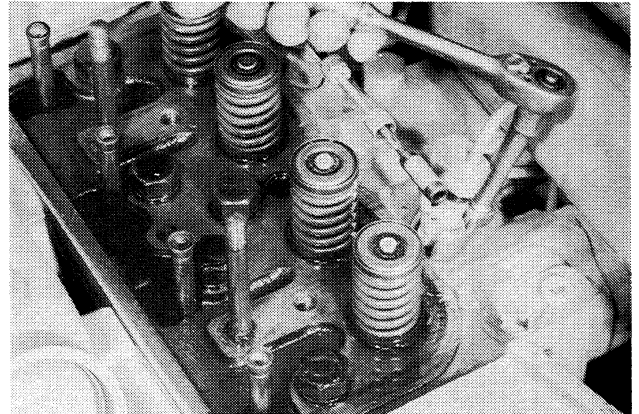

Loosen the retaining nut of the Number One nozzle using a 7/8" crowfoot wrench (Snap-On Tool Part Number AN-8508-14, flared nut type or AN-8506-8, open end type) with an extension and ratchet wrench.

**STEP 27**

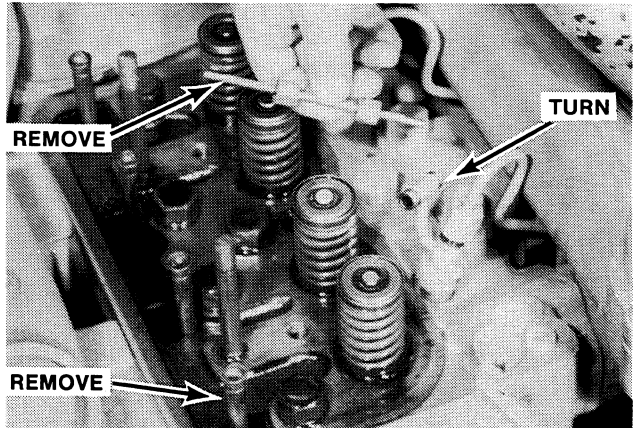

Remove the leak off line and turn the fuel injector nozzle towards the rear of the engine. Remove the Number One cylinder exhaust push rod.

**STEP 28**

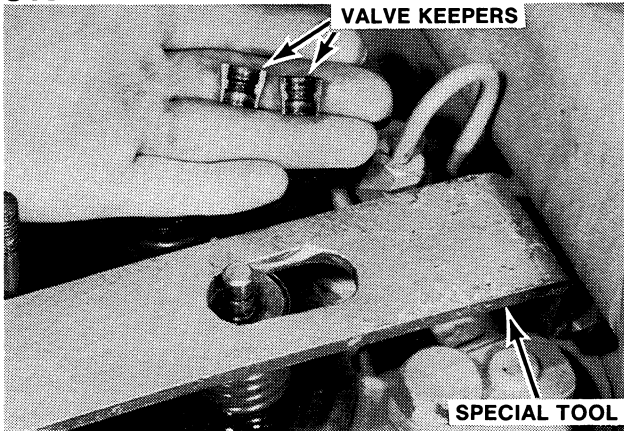

Push down the exhaust valve spring on the Number One cylinder, using a special tool and remove the valve keepers. See Page 3 for making this tool.

**STEP 29**

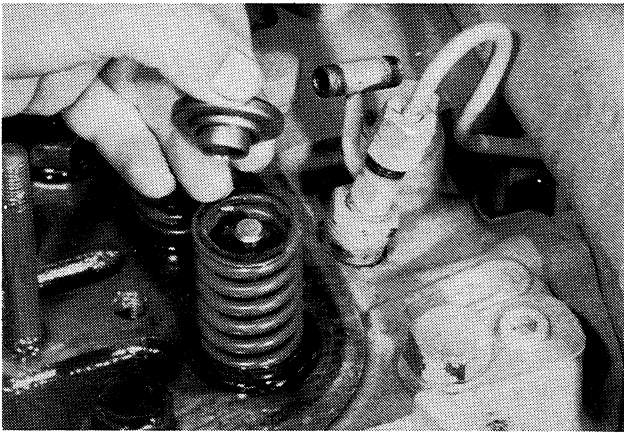

Remove the exhaust valve rotator.

**STEP 30**

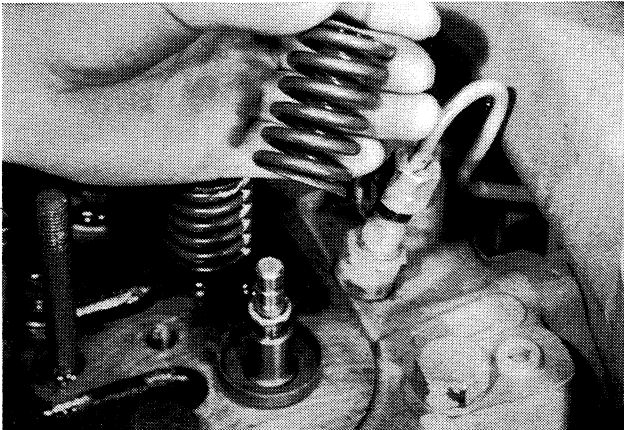

Remove the exhaust valve spring.

**STEP 31**

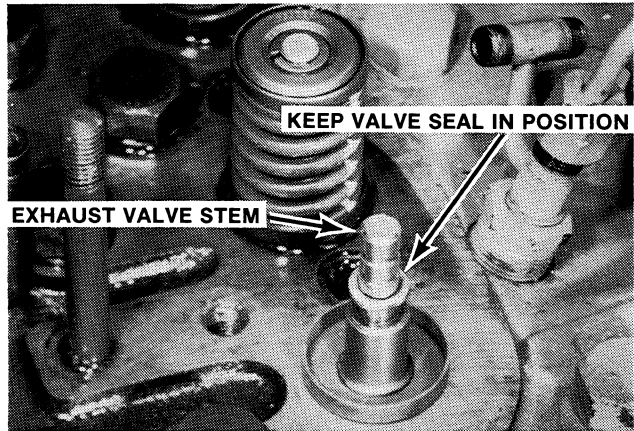

Keep the valve seal in position to prevent the valve from falling through the valve guide if the piston is moved too far. Install a dial indicator on the end of the valve stem with the valve setting on top of the piston.

**STEP 32**

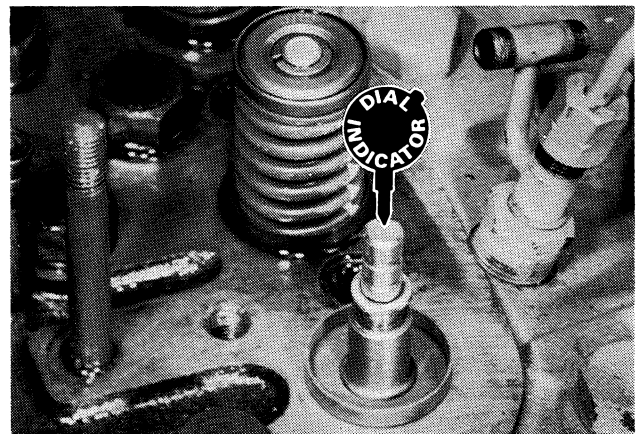
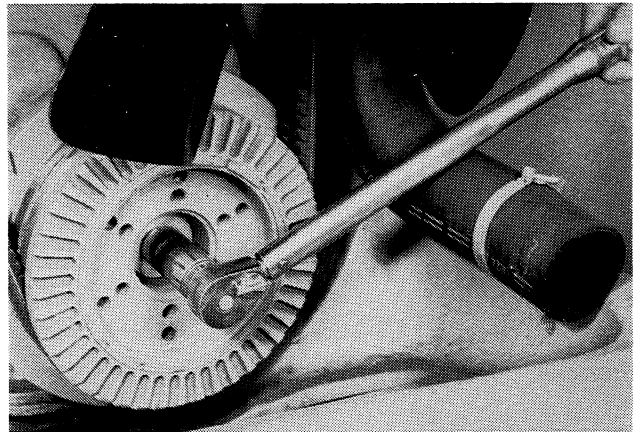

Turn the engine over clockwise until the dial indicator hand stops moving. Reset the indicator to zero.



**Suggest:**

**If the above button click is invalid.**

**Please download this document**

**first, and then click the above link**

**to download the complete manual.**

**Thank you so much for reading**

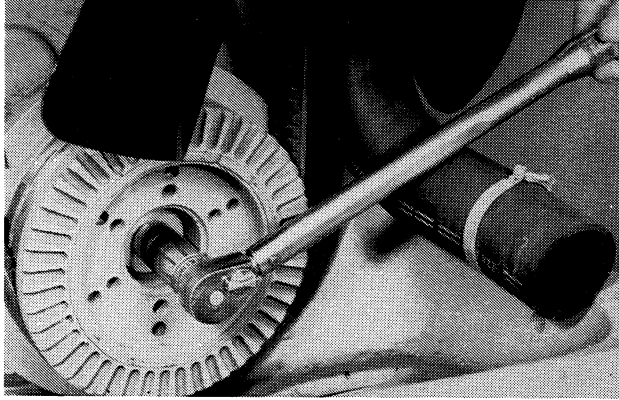
**STEP 33**

Turn the engine over clockwise, approximately 5 degrees until 0.010" (0.254 mm) shows on the dial. Put a mark on the crankshaft pulley in line with the timing pointer.

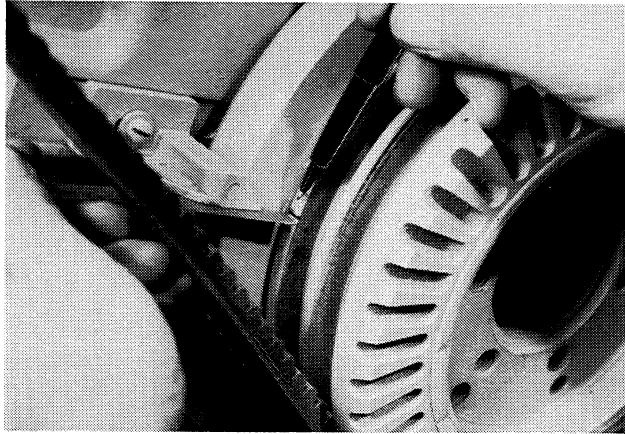

Turn the engine over counterclockwise past the zero mark on the indicator until 0.010" (0.254 mm) shows on the dial. Again, put a mark on the crankshaft pulley.

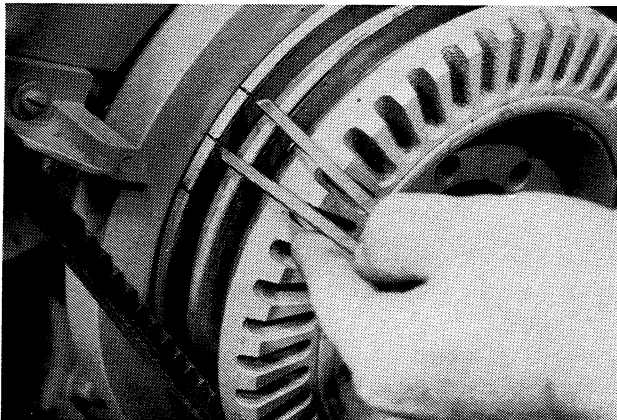
**STEP 34**

Half the distance between the two marks on the crankshaft pulley will be the Top Dead Center mark. If the marks are not the same as the original marks on the pulley, check the damper pulley for alignment marks as in Step 1.

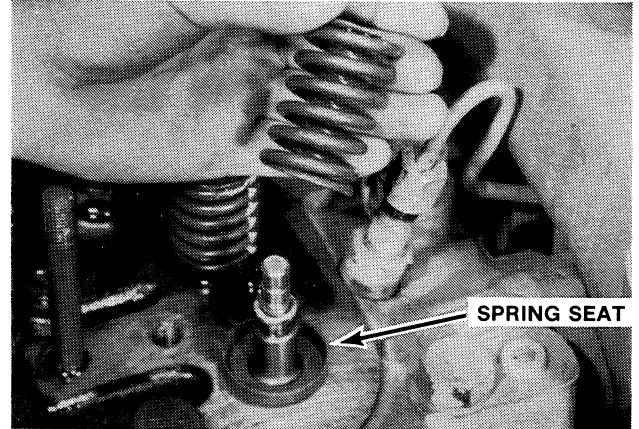
**STEP 35**

Turn the engine over to TDC and install the valve spring in the spring seat.

**NOTE:** Install either end of the spring against the spring seat because both ends of the spring are closed.

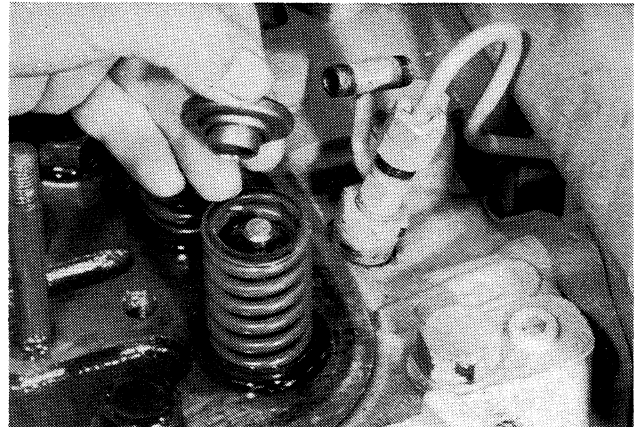
**STEP 36**

Install the valve rotator (flat side up).

**<https://www.ebooklibonline.com>**

Hello dear friend!

Thank you very much for reading.

Enter the link into your browser.

The full manual is available for immediate download.

**<https://www.ebooklibonline.com>**