

CX330 and CX350 Crawler Excavators

Table of Contents

DIVISION/SECTION	SECTION N°	REFERENCE N°
1 GENERAL INFORMATION		
Safety, general information and standard torque data	1001	7-27690GB
General specifications and special torque setting	1002	9-36450GB
2 ENGINE		
Removal and installation of the engine	2000	9-43540GB
Radiator and oil-cooler	2001	9-43480GB
Engine specifications	*	
Disassembly and assembly of the engine	*	
3 FUEL SYSTEM		
Fuel tank	3001	9-43470GB
Fuel engine system	*	
4 ELECTRICAL SYSTEM		
Electrical system, electrical and electronic troubleshooting	4001	9-40950GB
Inspection and maintenance of batteries and connecting a booster battery ...	4002	9-43460GB
Main and engine electronic control boxes	4003	9-43450GB
5 UNDERCARRIAGE		
Removal and installation of tracks	5001	9-42910GB
Rollers	5003	9-42920GB
Sprocket	5004	9-36890GB
Idler wheel and tension shock absorber	5005	9-43000GB
6 DRIVE TRAIN		
Drive motor and final drive transmission removal and installation	6001	9-43140GB
Swing reduction gear, removal and installation	6003	9-43210GB
Swing reduction gear, disassembly and assembly	6004	9-43220GB
Travel reduction gear assembly and disassembly	6005	9-43150GB
7 UNDERCARRIAGE HYDRAULICS		
8 UPPERSTRUCTURE HYDRAULICS		
Depressurising and decontaminating the hydraulic system, use of the vacuum pump and bleeding the components	8000	9-43500GB
Specifications, troubleshooting, checks and hydraulic pressure settings	8001	9-36260GB
Hydraulic reservoir removal and installation	8002	9-43230GB
Main and pilot pumps, removal and installation	8003	9-43530GB
Main hydraulic control valve, removal and installation	8004	9-43260GB
Attachment cylinders, removal and installation	8005	9-43250GB
Hydraulic swivel, removal and installation	8006	9-43390GB
Pilot blocs, removal and installation	8007	9-43400GB
Swing motor, removal and installation	8008	9-43200GB
Main hydraulic pump, disassembly and assembly	8010	9-43240GB
.....	8010	9-43330GB
Main hydraulic control valve, disassembly and assembly	8011	9-43550GB
Attachment cylinders, disassembly and assembly	8012	9-43320GB
Hand control levers, disassembly and assembly	8013	9-43340GB
Foot control levers, disassembly and assembly	8014	7-28300GB
Six-solenoid valves, disassembly and assembly	8015	9-43360GB
Caution valve, disassembly and assembly	8016	7-27942GB
Safety valve	8017	9-43380GB
Hydraulic swivel, disassembly and assembly	8018	9-43190GB
Swing motor, disassembly and assembly	8019	9-43440GB
Hydraulic functions	8020	9-42740GB
Travel hydraulic motor, disassembly and assembly	8021	9-43160GB

DIVISION/SECTION	SECTION N°	REFERENCE N°
9 UPPERSTRUCTURE		
Upperstructure, turntable and counterweight.....	9002	9-43410GB
Boom, dipper and bucket.....	9003	9-43420GB
Seat and seat belt.....	9004	9-40460GB
Cab and cab equipment.....	9005	9-43430GB
Air conditioning troubleshooting.....	9006	██████████
Air conditioning unit disassembly and assembly.....	9007	██████████
Air conditioning servicing.....	9008	██████████
Air conditioning components.....	9009	██████████
Large format hydraulic and electrical schematics.....	Pocket	7-29440GB

* *Consult the Engine Service Manual*

██████████ *Sections to be distributed at a later date*

NOTE: CASE Company reserves the right to make changes in the specification and design of the machine without prior notice and without incurring any obligation to modify units previously sold.

The description of the models shown in this manual has been made in accordance with the technical specifications known as of the date of design of this document.

Section

1001

**SAFETY, GENERAL INFORMATION
AND STANDARD TORQUE DATA**

TABLE OF CONTENTS

GENERAL INFORMATION	3
SAFETY	4
STANDARD TORQUE DATA FOR CAP SCREWS AND NUTS.....	6

<https://www.ebooklibonline.com>

Hello dear friend!

Thank you very much for reading.

Enter the link into your browser.

The full manual is available for immediate download.

<https://www.ebooklibonline.com>

GENERAL INFORMATION

Cleaning

Clean all metal parts except bearings, in a suitable cleaning solvent or by steam cleaning. Do not use caustic soda for steam cleaning. After cleaning, dry and put oil on all parts. Clean oil passages with compressed air. Clean bearings in a suitable cleaning solvent. Dry the bearings completely and put oil on the bearings.

Inspection

Check all parts when the parts are disassembled. Replace all parts that have wear or damage. Small scoring or grooves can be removed with a hone or crocus cloth. Complete a visual inspection for indications of wear, pitting and their replacement of parts necessary to prevent early failures.

Bearings

Check bearings for easy action. If bearings have a loose fit or rough action, replace the bearing. Wash bearings with a suitable cleaning solvent and permit to air dry. **DO NOT DRY BEARINGS WITH COMPRESSED AIR.**

Needle Bearings

Before you press needle bearings in a bore always remove any metal protrusions in the bore or edge of the bore. Before you press bearings into position, put petroleum jelly on the inside and outside diameter of the bearings.

Gears

Check all gears for wear and damage. Replace gears that have wear or damage.

Oil Seals, O-rings and Gaskets

Always install new oil seals, O-rings and gaskets. Put petroleum jelly on seals and O-rings.

Shafts

Check all shafts that have wear or damage. Check the bearing and oil seal surfaces of the shafts for damage.

Service Parts

Always install genuine Case service parts. When ordering refer to the Parts Catalog for the correct part number of the genuine Case replacement items. Failures due to the use of other than genuine Case replacement parts are not covered by warranty.

Lubrication

Only use the oils and lubricants specified in the Operator's or Service Manuals. Failures due to the use of non-specified oils and lubricants are not covered by warranty.

SAFETY



This symbol means ATTENTION! BECOME ALERT! YOUR SAFETY IS INVOLVED. The message that follows the symbol contains important information about safety. Carefully read the message. Make sure you fully understand the causes of possible injury or death.

To prevent injury always follow the Warning, Caution and Danger notes in this section and throughout the manual.

Place a "Do not operate" tag on the starter switch key before carrying out any service or repair work on the machine.



WARNING: *Read the operator's manual to familiarize yourself with the correct control functions.*



WARNING: *Operate the machine and equipment controls from the seat position only. Any other method could result in serious injury.*



WARNING: *This is a one man machine, no riders allowed.*



WARNING: *Before starting engine, study Operator's Manual safety messages. Read all safety signs on machine. Clear the area of other persons. Learn and practice safe use of controls before operating.*

It is your responsibility to understand and follow manufacturers instructions on machine operation, service and to observe pertinent laws and regulations. Operator's and Service Manuals may be obtained from your Case dealer.



WARNING: *If you wear clothing that is too loose or do not use the correct safety equipment for your job, you can be injured. Always wear clothing that will not catch on objects. Extra safety equipment that can be required includes hard hat, safety shoes, ear protection, eye or face protection, heavy gloves and reflector clothing.*



WARNING: *When working in the area of the fan belt with the engine running, avoid loose clothing if possible, and use extreme caution.*



WARNING: *When doing checks and tests on the equipment hydraulics, follow the procedures as they are written. DO NOT change the procedure.*



WARNING: *When putting the hydraulic cylinders on this machine through the necessary cycles to check operation or to remove air from a circuit, make sure all people are out of the way.*



WARNING: Use insulated gloves or mittens when working with hot parts.



WARNING: Lower all attachments to the ground or use stands to safely support the attachments before you do any maintenance or service.



WARNING: Pin sized and smaller streams of hydraulic oil under pressure can penetrate the skin and result in serious infection. If hydraulic oil under pressure does penetrate the skin, seek medical treatment immediately. Maintain all hoses and tubes in good condition. Make sure all connections are tight. Make a replacement of any tube or hose that is damaged or thought to be damaged. DO NOT use your hand to check for leaks, use a piece of cardboard or wood.



WARNING: When removing hardened pins such as a pivot pin, or a hardened shaft, use a soft head (brass or bronze) hammer or use a driver made from brass or bronze and a steel head hammer.



WARNING: When using a hammer to remove and install pivot pins or separate parts using compressed air or using a grinder, wear eye protection that completely encloses the eyes (approved goggles or other approved eye protectors).



WARNING: Use suitable floor (service) jacks or chain hoist to raise wheels or tracks off the floor. Always block machine in place with suitable safety stands.



WARNING: When servicing or repairing the machine, keep the shop floor and operator's compartment and steps free of oil, water, grease, tools, etc. Use an oil absorbing material and/or shop cloths as required. Use safe practices at all times.



WARNING: Some components of this machine are very heavy. Use suitable lifting equipment or additional help as instructed in this Service Manual.



WARNING: Engine exhaust fumes can cause death. If it is necessary to start the engine in a closed place, remove the exhaust fumes from the area with an exhaust pipe extension. Open the doors and get outside air into the area.



WARNING: When the battery electrolyte is frozen, the battery can explode if (1), you try to charge the battery, or (2), you try to jump start and run the engine. To prevent the battery electrolyte from freezing, try to keep the battery at full charge. If you do not follow these instructions, you or others in the area can be injured.

STANDARD TORQUE DATA FOR CAP SCREWS AND NUTS

Tightening of Cap Screws and Nuts

Tighten alternately so that tightening torque can be applied evenly. The numbers in the figure below indicate the order of tightening.

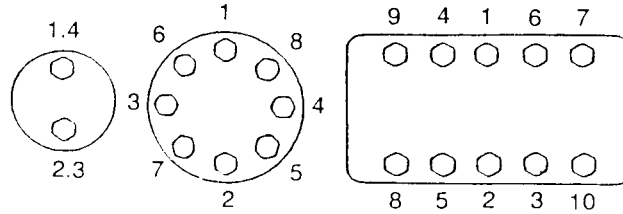

JS00481A

Cap screws which have had Loctite used (white residue remains after removal) should be cleaned with light oil or suitable cleaning solvent and dried. Apply 2-3 drops of Lo ctite to the thread portion of the c ap screw and then tighten.

Torque Table

Tighten cap screws and nuts according to the table below if there are no other special instructions.

Cap Screw Name Size (Size)		M6	M8	M10	M12	M14	M16	M18	M20	
Cap Screw	Spanner	[mm]	10	13	17	19	22	24	27	30
		[in.]	0.39	0.51	0.67	0.75	0.87	0.95	1.06	1.18
	Tightening torque	[Nm]	6.9	19.6	39.2	58.8	98.1	157.2	196.0	274.0
		[lb-ft]	5.1	14.5	29.0	43.4	72.5	116.0	144.6	202.4
Socket Head Cap Screw	Spanner	[mm]	5	6	8	10	12	14	14	17
		[in.]	0.20	0.24	0.32	0.39	0.47	0.55	0.55	0.67
	Tightening torque	[Nm]	8.8	21.6	42.1	78.4	117.6	176.4	245.0	343.0
		[lb-ft]	6.5	15.9	31.1	57.8	86.8	130.1	180.8	253.1

Section 1002

1002

SPECIFICATIONS AND SPECIAL TORQUE SETTINGS

TABLE OF CONTENTS

TYPE, SERIAL NUMBER AND YEAR OF MANUFACTURE OF THE MACHINE	3
Machine	3
Engine	3
Serial numbers of the components	3
INGREDIENTS	4
Hydraulic fluid	4
Transmission assembly oil	4
Greases	4
Engine oil	5
Viscosity of oils/Operating range of oils	5
Fuel	6
Antifreeze/anticorrosive	6
Environment	6
Plastic and resin parts	6
SPECIFICATIONS.....	7
Engine	7
Capacities	7
Electrical system	7
Hydraulic system	8
Cylinder	8
Control valve	9
Swing	9
Travel	9
Undercarriage	9
Attachment.....	10
Weight of components	10
DIMENSIONS AND WEAR LIMIT OF THE TRACK ASSEMBLY	11
Sprocket	11
Idler wheel.....	12
Upper roller	13
Lower roller	14
Track	15
DIMENSIONS AND WEAR LIMITS OF ATTACHMENT LINKAGES	16
Boom foot/Frame	16
Boom cylinder foot/Frame	17
Boom cylinder head/Boom	17
Dipper cylinder foot/Boom	18
Boom/Dipper	18
Dipper cylinder head/Dipper.....	18
Bucket cylinder foot/Dipper	19
Connecting rod/Dipper	19
Compensator/Bucket.....	19
Connecting rod/Compensator/Bucket cylinder head.....	20
Dipper/Bucket.....	20
SPECIAL TORQUE SETTINGS.....	21
MACHINE OVERALL DIMENSIONS.....	24



WARNING: *This symbol is used in this manual to indicate important safety messages. Whenever you see this symbol, carefully read the message which follows. Your safety depends on it.*

TYPE, SERIAL NUMBER AND YEAR OF MANUFACTURE OF THE MACHINE

For all part orders, request for information or assistance, always specify the type and the serial number of the machine to your CASE dealer.

Fill in the following lines with the required information: Type, serial number, year of manufacture of the machine and the serial numbers of the hydraulic and mechanical components.

Machine

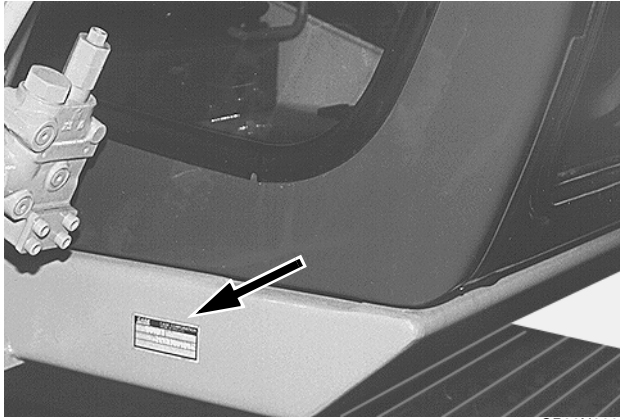

CP98N006

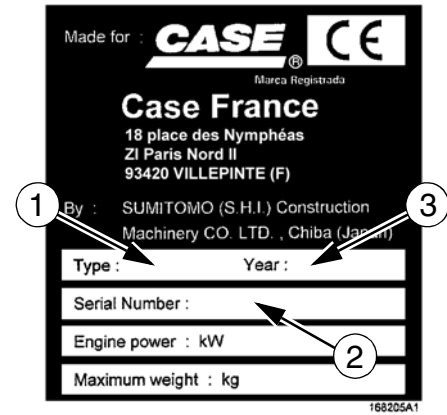

168205A1

CS01J532

- (1) Type
- (2) Serial number
- (3) Year of manufacture

Engine

Make and type

Serial number

Serial numbers of the components

Hydraulic pump.....

Swing reduction gear.....

Travel reduction gears

Travel control valve

Attachment control valve

Swing control valve.....

INGREDIENTS

The ingredients must correspond to specific characteristics for every usage.



WARNING: *You must respect the operating conditions for the different ingredients.*

Hydraulic fluid

The CASE hydraulic fluid is specially adapted for high pressure and CASE's hydraulic circuit. The type of fluid to be used depends on the ambient temperature.

Temperate climates

-20°C to +40°C

Fluid type: ISO VG 46

CASE reference: POHYDR

Hot climates

0°C to +60°C

Fluid type: ISO VG 100

CASE reference: POHYPC

Cold climates

-40°C to +20°C

Fluid type: ISO VG 22

CASE reference: POHYPF

Temperate climate biodegradable fluid:

This yellow-coloured fluid is miscible with standard fluid. When introducing this fluid, it is recommended to drain the hydraulic system completely.

Fluid type: ISO VG 46

CASE reference: CASYNTH 46

These different grades of fluids must comply with the CASE specification.

Transmission assembly oil

Extreme pressure oil used for transmission assemblies in housing.

Extreme pressure oil TYPE API GL5 GRADE 80W90 and ISO VG 150

Greases

The type of grease to be used depends on the ambient temperature.

Hot and temperate climates

-20°C to +60°C

Extreme pressure EP NLGI grade 2 grease with molybdenum disulfide.

Cold climates

-40°C to +20°C

Extreme pressure EP NLGI grade 0 grease.

Engine oil

The CASE No. 1 engine oil is recommended for your engine. This oil ensures proper lubrication of your engine for all operating conditions.

If you are unable to procure the CASE No. 1 Multiperformance or Performance engine oil, use the corresponding oil from the API/CG/CF category.

NOTE: Do not put any performance additives or any other additives in the engine housing. The oil changing intervals are indicated in this manual based on tests carried out on CASE lubricants.



RD97F136



RD97F100

Viscosity of oils/Operating range of oils

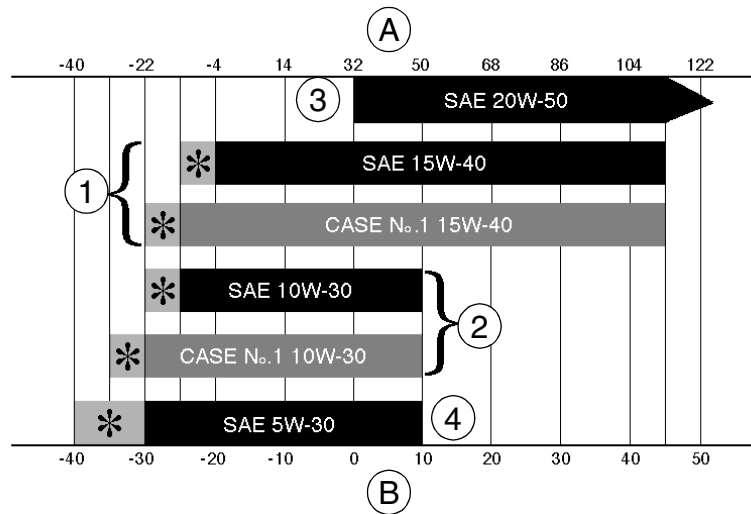

(A) FAHRENHEIT TEMPERATURE

(B) CELSIUS TEMPERATURE

(1) ALL SEASONS

(*) SHOWS THAT IT IS NECESSARY TO USE AN OIL HEATER OR THERMAL COOLER.

(2) WINTER

(3) TROPICAL

(4) ARCTIC

CS98M561

Fuel

The fuel to be used must comply with the D975 norm of the American Society for Testing and Materials (ASTM).

Use type No. 2 fuel, use of other fuels can cause a loss of engine power and excessive fuel consumption.

In cold weather, it is provisionally accepted that a mixture of No. 1 and No. 2 fuels be used. Contact your fuel supplier.

If the temperature drops below the freezing point of the fuel (point where paraffin appears), paraffin crystals in the fuel will cause loss of engine power or starting trouble.

IMPORTANT: *In cold weather, fill up the reservoir with fuel after each workday, in order to avoid the formation of condensation.*

Storing fuel

Prolonged storage of fuel promotes the accumulation of foreign bodies or condensed moisture in the storage tank. Many engine failures are caused by the presence of water in fuel.

The storage tank must be placed outside and the fuel should be maintained at as low a temperature as possible. Drain the condensed moisture at regular intervals.

Antifreeze/anticorrosive

Use the antifreeze in all seasons to protect the coolant system from corrosion and to avoid any risk of freezing.

In environments with a temperature greater than -36°C , use a 50% mixture of antifreeze in an ethylene glycol base.

In environments with a temperature less than -36°C , it is recommended that you use a 40% water and 60% antifreeze mixture.

Environment

Before carrying out any maintenance operation on this machine and before throwing away the liquids or lubricants used, always think of the environment. Never throw oil or liquids on the ground and never put them in leaking containers.

Consult your local centre for ecological recycling for information on the appropriate method for disposing off these substances.

Plastic and resin parts

When cleaning plastic parts, on the console, the instrument panel, the indicator and gauges etc., do not use petrol, paraffin, paint solvents, etc. Use only water, soap and a soft cloth.

The use of petrol, paraffin, paint solvents etc., causes discoloration, cracks or deformation of these parts.

SPECIFICATIONS

CX330

CX350

Engine

Make Isuzu Isuzu

Model 6HK1XQB

Type: Four stroke, water cooled with overhead valves, direct injection in-line cylinder (electronic control) with turbo-charger.

Number of cylinders 6

Bore and stroke 115 x 125 mm

Displacement 7790 cc

Operating conditions

Idle 900 rpm

Max speed 2000 rpm

Power ECC 1289 185.45 kW (248.6 HP)

Max torque 962.3 Nm at 1600 rpm

Capacities

Engine oil capacity 33 litres

Engine cooling circuit 42 litres

Capacity of only the radiator 21 litres

Fuel reservoir 580 litres

Hydraulic fluid reservoir capacity 175 litres

Total hydraulic circuit capacity 350 litres

Capacity of only the oil-cooler 16.5 litres

Travel reduction gear housing capacity 11 litres

Swing drive housing capacity 6 litres

Idler pulley capacity 250 cc

Upper roller capacity 245 to 250 cc

Lower roller capacity 280 cc

NOTE: *These capacities are given only for information purposes. To check the fluid levels, always use the oil gauge, visual gauges or the filler cap.*

Electrical system

Type of system 24 volts earth negative

Alternator amperage 50 amperes

Battery

Number of batteries required 2

Voltage of each battery 12 volts

Capacity 140 Ah

Reserve 160 min

Cold startability at -17° 800 A

Load for load control 400 A

Starter

Voltage 24 volts

Power 5 kW

Voltage regulator built-in, without adjustment

Hydraulic system

Main hydraulic pump

Variable flow double pump, with axial pistons.

Maximum flow.....	2 x 284 l/min
Displacement.....	2 x 140 cc

Hydraulic pilot pump

Fixed flow pump

Max flow	26.4 l/min
Displacement.....	13 cc

Pressure setting

Pilot circuit relief	39 ± 1 bar
Main circuit relief (standard)	343 ± 3 bar
Main circuit relief (Power-up)	373 ± 5 bar
Secondary relief (Boom raising, dipper and bucket).....	392 ± 5 bar
Secondary relief (boom lower).....	274 ± 5 bar
Secondary relief (swing)	294 ± 4 bar
Secondary relief (travel)	380 ± 5 bar
Safety valve (boom and dipper).....	392 ± 5 bar

Cylinder

Boom cylinder

Cylinder bore	145 mm
Rod diameter	100 mm
Stroke	1495 mm

Dipper cylinder

Cylinder bore	170 mm
Rod diameter	120 mm
Stroke	1748 mm

Bucket cylinder

Cylinder bore	150 mm
Rod diameter	105 mm
Stroke	1210 mm

Cylinder leakage - attachment lowering (without load)

Boom cylinders (rods retracted)	3 mm/5 min
Dipper cylinder (rod extended)	5 mm/5 min
Dipper cylinder (rod extended)	7 mm/5 min
Total (at the end of the attachment).....	200 mm/5 min

Cylinder speed (in S mode)

Boom raised (bucket open and on the ground)	4.6 ± 0.5 sec.
Boom lowered (bucket open).....	3.7 ± 0.5 sec.
Dipper extended	3.7 ± 0.5 sec.
Dipper retracted.....	4.8 ± 0.5 sec.
Bucket open.....	3.0 ± 0.5 sec.
Bucket closed	5.4 ± 0.5 sec.

Control valve

Five-element control valve for dipper, boom acceleration, swing, option and right travel.

Four-element control valve for dipper, bucket, boom acceleration and left travel.

Load holding relief valve for boom and dipper.

CX330

CX350

Swing

Fixed flow engine with axial pistons.

Automatic disk brakes.

Upperstructure frame swing speed.....	9.6 rpm
Displacement.....	180 cc
Work flow.....	284 l/min
Reduction ratio.....	27.143
Brake torque.....	≥ 927.1 Nm
Minimum brake release pressure.....	29 bar
Permissible motor leak.....	16 l/min

Travel

Two-speed motor with axial pistons.

Automatic disk brakes.

Low speed.....	3.2 kph
High speed.....	5.5 kph
Gradeability.....	70% (35°)
Tractive effort.....	27 400 daN
Displacement.....	290.7/170.1 cc
Work flow.....	284.2 l/min
Reduction ratio.....	40.4675
Braking torque (reduction gear excluded).....	≥ 902 Nm
Number of sprocket turns (10 turns)	
Mode "S", high speed.....	16.6 ± 0.6 sec.
Mode "S", low speed.....	27.8 ± 0.6 sec.
Permissible deviation in travel over a distance of 20 m	
Mode "H", full speed.....	1 m
Permissible motor leak.....	14 l/min

Undercarriage

Monobloc frame with fabricated elements.

Lubricated rollers and idler wheels.

Grease track tension.

Weight load on track

with 600 mm track pads.....	0.64 bar	0.67 bar
with 700 mm track pads.....	0.55 bar	0.58 bar
with 800 mm track pads.....	0.49 bar	0.52 bar
with 900 mm track pads.....	0.44 bar	
Track tension.....		340 to 360 mm

Attachment

Digging force		24 840 daN	
Break-out force			
2.20 m dipper.....		24 600 daN	
2.60 m dipper.....		21 100 daN	
2.65 m dipper.....	-		21 100 daN
3.20 m dipper.....	17 800 daN		
3.25 m dipper.....	-		17 800 daN
4.00 m dipper.....	15 260 daN		

Weight of components

Engine		650 kg	
Hydraulic pump.....		130 kg	
Attachment control valve		192 kg	
Swing motor and reduction gear assembly		407 kg	
Travel motor and reduction gear assembly		380 kg	
Boom cylinder.....		287 kg	
Dipper cylinder.....		515 kg	
Bucket cylinder		280 kg	
Counterweight	6400 kg		7400 kg
Cab		254 kg	
Turntable.....		590 kg	
Complete upperstructure	13 860kg		14 850 kg
Hydraulic swivel		54 kg	
Complete chassis	12 200 kg		12 400 kg
Machine without attachment.....	26 640 kg		27 840 kg
Attachment	7050 kg		7860 kg
Complete boom	3370 kg		3660 kg
Complete dipper	2110 kg		2300 kg
Radiator and oil-cooler assembly		160 kg	
Fuel reservoir.....		235 kg	
Hydraulic reservoir.....		202 kg	
Idler wheel		154 kg	
Upper roller.....		44 kg	
Lower roller.....		60 kg	
Tension damper		497 kg	
600 mm track.....		2217 kg	
700 mm track.....		2417 kg	
800 mm track.....		2682 kg	
900 mm track.....		2817 kg	

DIMENSIONS AND WEAR LIMIT OF THE TRACK ASSEMBLY

Sprocket Dimensions

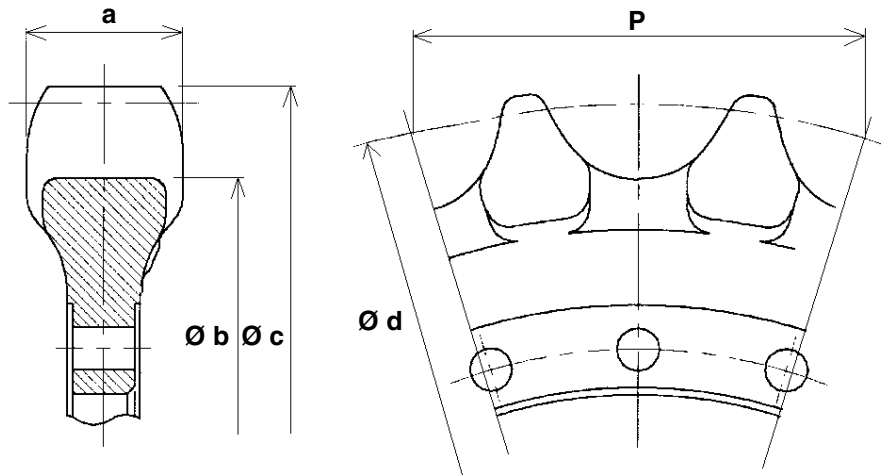

CS01B512

Mark		Dimension (mm)
a	Standard	83
	Limit	73
Ø b	Standard	660.7
	Limit	649.2
Ø c	Standard	748
	Limit	738
Ø d	Standard	732.5
	Limit	---
P	Standard	215.9
	Limit	---

Gauge

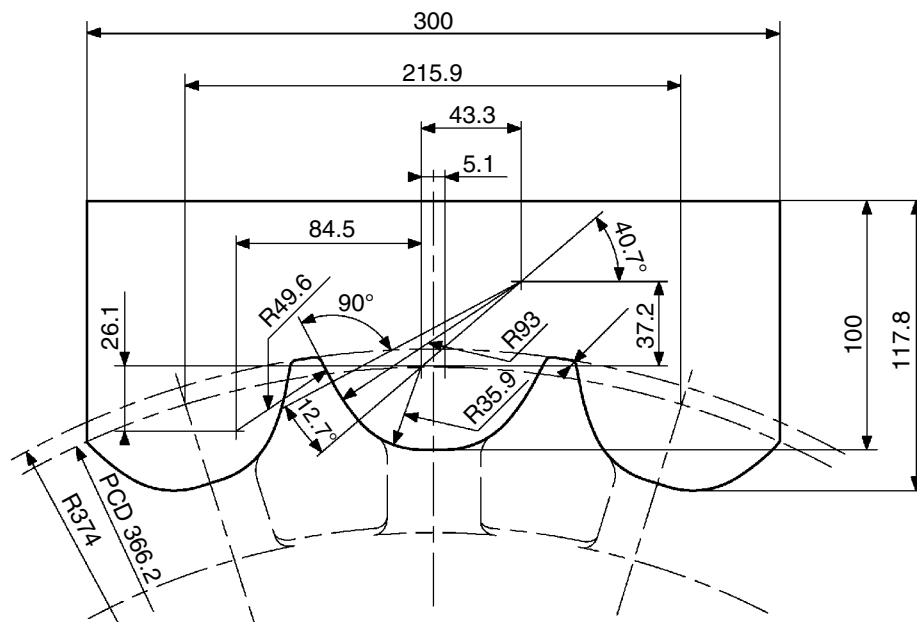

Idler wheel

Dimensions

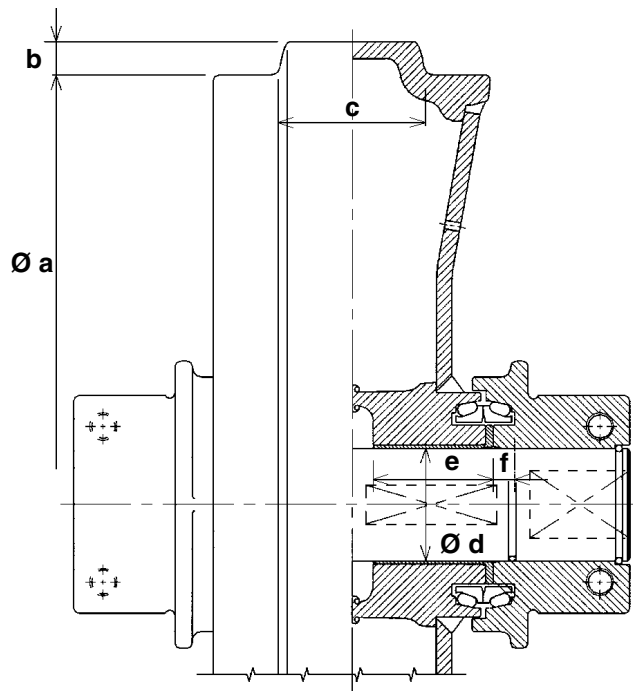

Mark		Dimension (mm)
Ø a	Standard	560
	Limit	550
b	Standard	22.5
	Limit	---
c	Standard	102
	Limit	92
Ø d (shaft)	Standard	85
	Limit	84
Ø d (bushing)	Standard	85
	Limit	86
e	Standard	82
	Limit	81
f	Standard	19
	Limit	18.6

CS01B514

Gauge

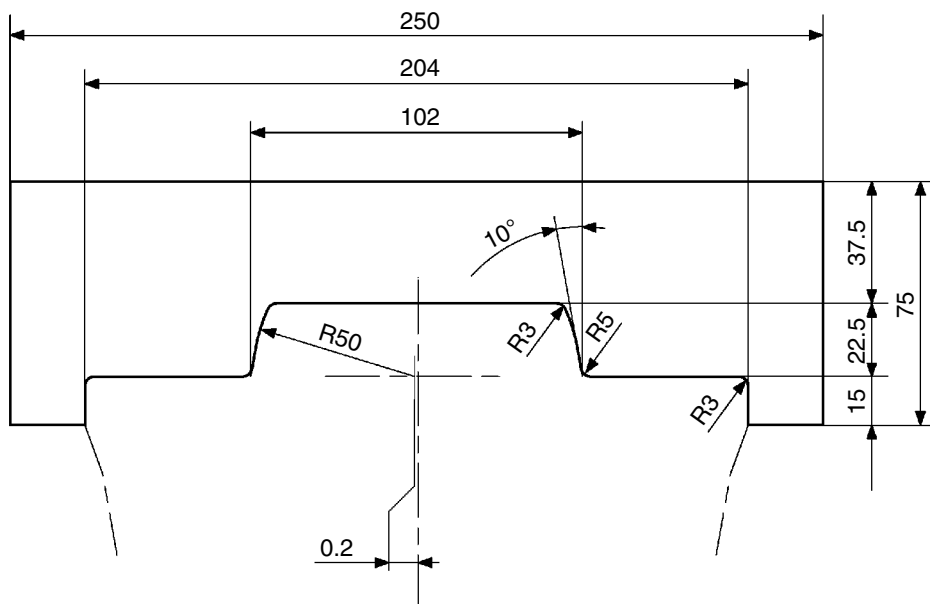

CI01N502

Upper roller

Dimensions

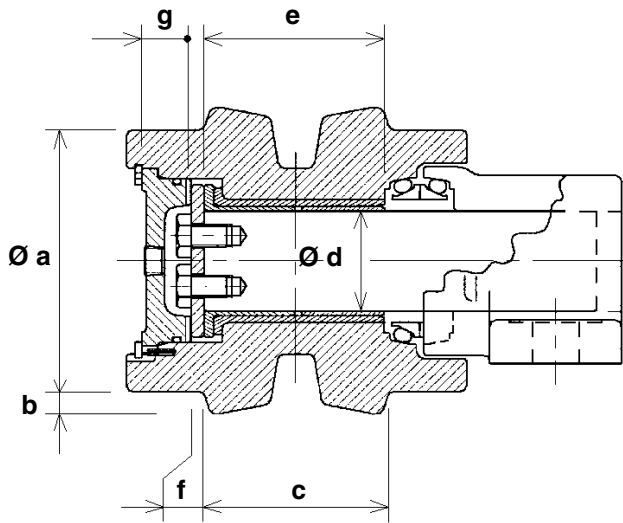

Mark		Dimension (mm)
$\varnothing a$	Standard	150
	Limit	140
b	Standard	15
	Limit	---
c	Standard	104
	Limit	---
$\varnothing d$ (shaft)	Standard	65
	Limit	64
$\varnothing d$ (bushing)	Standard	65
	Limit	66
e	Standard	69
	Limit	68
f	Standard	9
	Limit	8.5
g	Standard	30
	Limit	---

CS01B516

Gauge

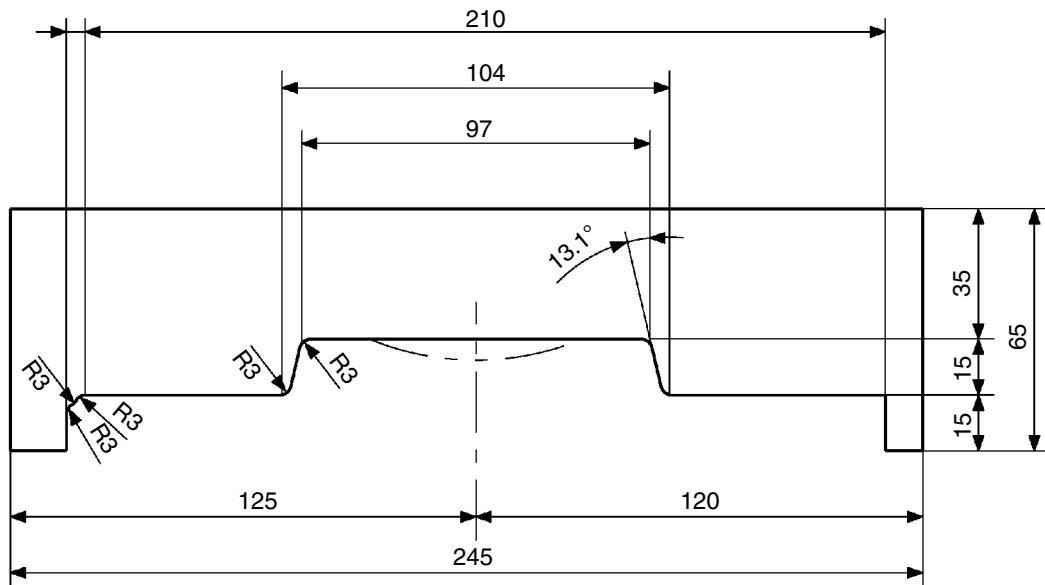

CI01N503

Lower roller

Dimensions

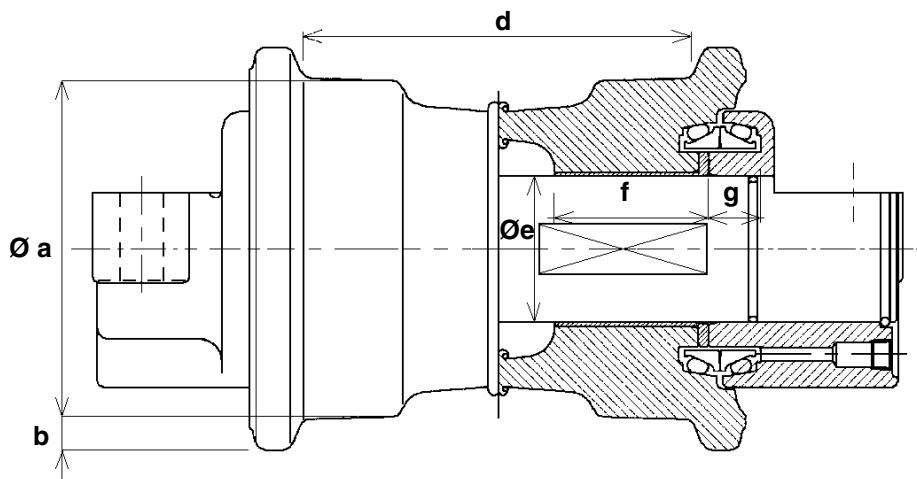

CS01B518

Mark		Dimension (mm)	Mark		Dimension (mm)
Ø a	Standard	180	Ø e (ring)	Standard	75
	Limit	170		Limit	76
b	Standard	25	f	Standard	82
	Limit	20		Limit	81
d	Standard	216	g	Standard	17.5
	Limit	224		Limit	17
Ø e (shaft)	Standard	75			
	Limit	74			

Gauge

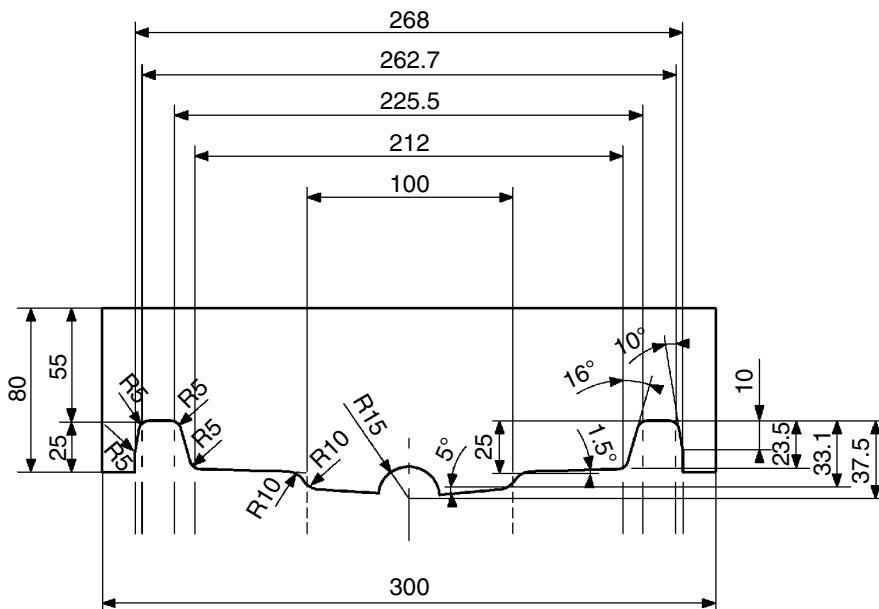

CI01N504

Track

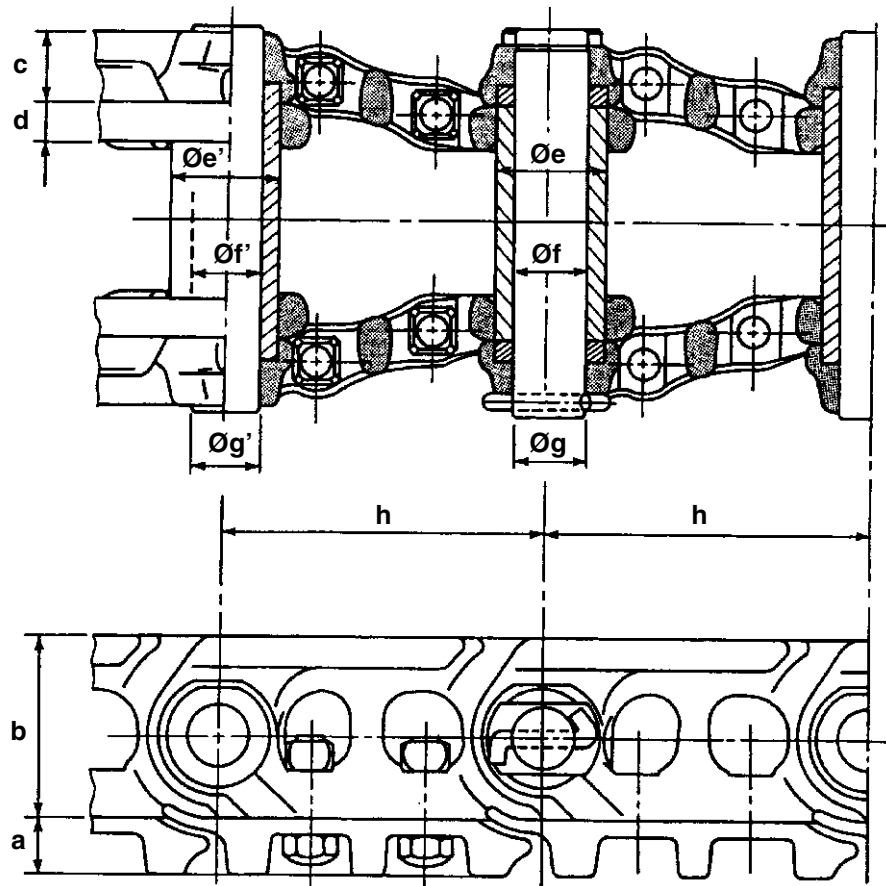

CS01B520

Mark		Dimension (mm)	Mark		Dimension (mm)
a	Standard	49	Ø e (ring)	Standard	71.35
	Limit	34		Limit	67
b	Standard	129	Ø f (ring)	Standard	47.9
	Limit	124		Limit	50.4
c	Standard	43	Ø g (shaft)	Standard	47
	Limit	41		Limit	45
d	Standard	28.4	h	Standard	215.9
	Limit	27		Limit	---
			Ø e' (bushing)	Standard	71.35
				Limit	67
			Ø f' (bushing)	Standard	48.4
				Limit	50.8
			Ø g' (shaft)	Standard	47.6
				Limit	45

DIMENSIONS AND WEAR LIMITS OF ATTACHMENT LINKAGES

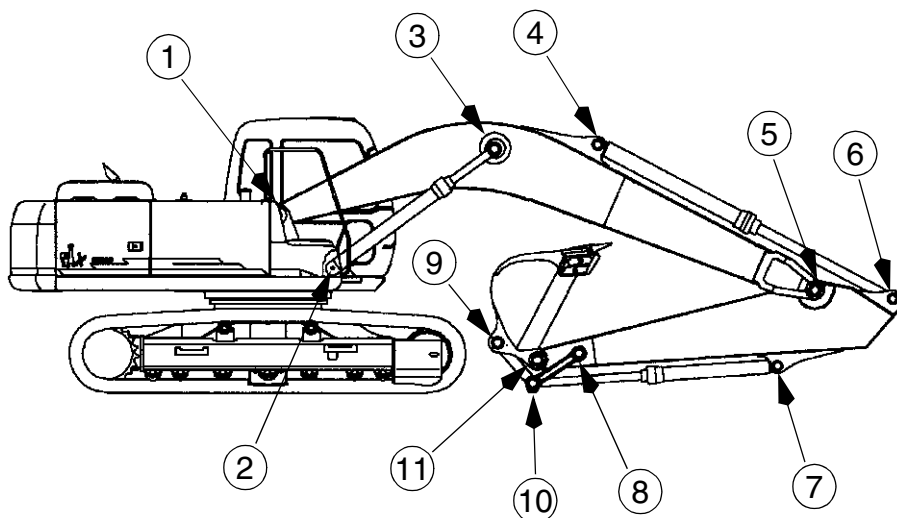

CS01B521

1. Boom foot/Frame

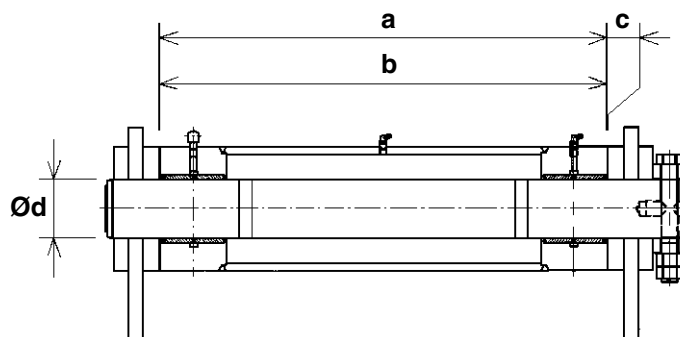

CS01B522

Mark		Dimension (mm)
a	Standard	860
	Limit	868
b	Standard	859
	Limit	857
c (a - b)	Standard	1.5 to 4
	Limit	Shims
Ø d (shaft)	Standard	110
	Limit	109
Ø d (bushing)	Standard	110
	Limit	111.5

2. Boom cylinder foot/Frame

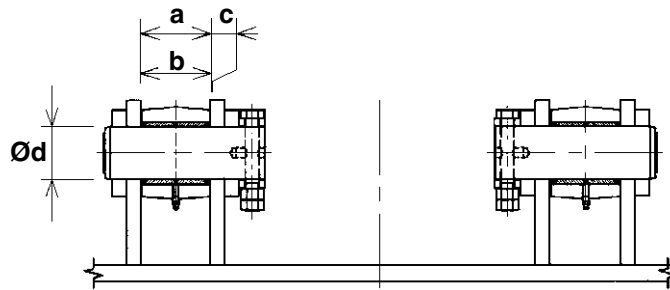

CS01B523

Mark		Dimension (mm)
a	Standard	131
	Limit	137
b	Standard	130
	Limit	127
c (play)	Standard	1 to 3.5
	Limit	Shims
Ø d (shaft)	Standard	90
	Limit	89
Ø d (bushing)	Standard	90
	Limit	91.5

3. Boom cylinder head/Boom

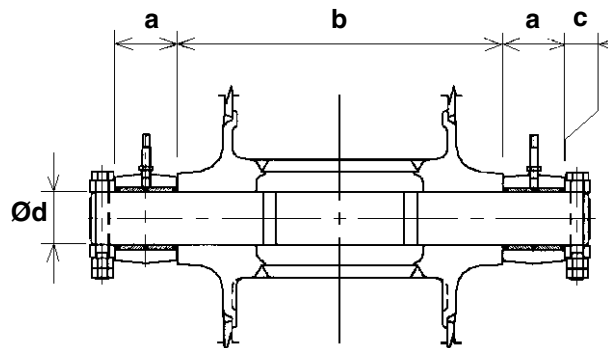

CS01B524

Mark		Dimension (mm)
a	Standard	123
	Limit	120
b	Standard	669
	Limit	665
c (play)	Standard	1.5 to 3
	Limit	Shims
Ø d (shaft)	Standard	110
	Limit	109
Ø d (bushing)	Standard	110
	Limit	111.5

4. Dipper cylinder foot/Boom

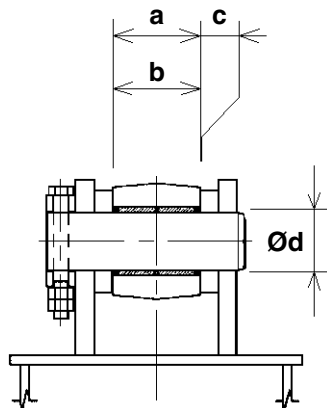

CS01B525

Mark		Dimension (mm)
a	Standard	146
	Limit	152
b	Standard	145
	Limit	143
c (a - b)	Standard	1 to 3.5
	Limit	Shims
Ø d (shaft)	Standard	100
	Limit	99
Ø d (bushing)	Standard	100
	Limit	101.5

5. Boom/Dipper

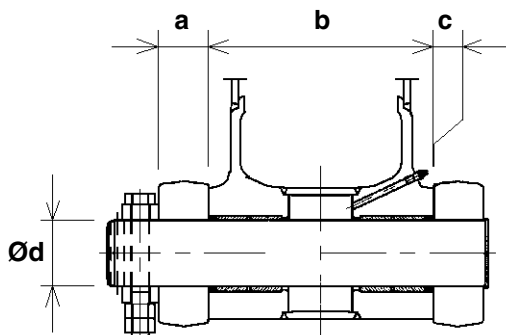

CS01B526

Mark		Dimension (mm)
a	Standard	89
	Limit	87
b (boom)	Standard	392
	Limit	395
b (dipper)	Standard	391.5
	Limit	389
c (play)	Standard	0.5 to 2
	Limit	Shims
Ø d (shaft)	Standard	115
	Limit	114
Ø d (dipper)	Standard	115
	Limit	116.5
Ø d (boom)	Standard	115
	Limit	116.5

6. Dipper cylinder head/Dipper

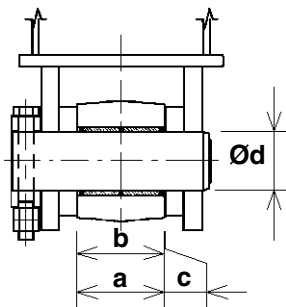

CS01B527

Mark		Dimension (mm)
a	Standard	146
	Limit	151
b	Standard	145
	Limit	143
c (a - b)	Standard	0.5 to 3
	Limit	Shims
Ø d (shaft)	Standard	100
	Limit	99
Ø d (bushing)	Standard	100
	Limit	101.5



Suggest:

If the above button click is invalid.

Please download this document

first, and then click the above link

to download the complete manual.

Thank you so much for reading

7. Bucket cylinder foot/Dipper

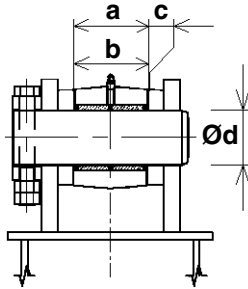

CS01B528

Mark		Dimension (mm)
a	Standard	146
	Limit	152
b	Standard	145
	Limit	143
c (a - b)	Standard	1 to 3.5
	Limit	Shims
Ø d (shaft)	Standard	95
	Limit	94
Ø d (bushing)	Standard	95
	Limit	96.5

8. Connecting rod/Dipper

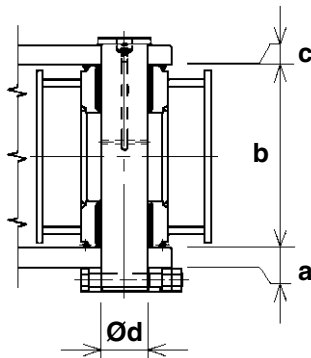

CS01B529

Mark		Dimension (mm)
a	Standard	50
	Limit	47
b	Standard	375
	Limit	371
c (play)	Standard	1 to 2
	Limit	Shims
Ø d (shaft)	Standard	85
	Limit	84
Ø d (bushing)	Standard	85
	Limit	86.5

9. Compensator/Bucket

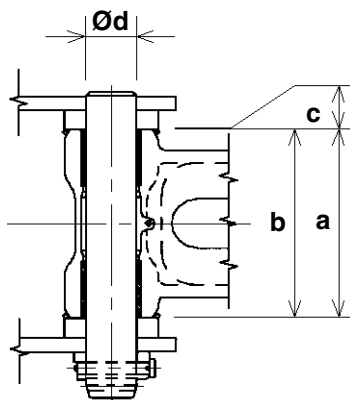

CS01B530

Mark		Dimension (mm)
a	Standard	50
	Limit	47
b	Standard	375
	Limit	371
c (play)	Standard	1 to 2
	Limit	Shims
Ø d (shaft)	Standard	85
	Limit	84
Ø d (bushing)	Standard	85
	Limit	86.5

<https://www.ebooklibonline.com>

Hello dear friend!

Thank you very much for reading.

Enter the link into your browser.

The full manual is available for immediate download.

<https://www.ebooklibonline.com>