

**CX26B  
CX30B  
Series 2**  
Mini Excavator

**SERVICE MANUAL**

Part number 84563194B

English

April 2014

Copyright © 2014 CNH Industrial Italia S.p.A. All Rights Reserved.

**CASE**  
CONSTRUCTION

# Contents

---

## INTRODUCTION

Engine.....	10
[10.001] Engine and crankcase .....	10.1
[10.102] Pan and covers .....	10.2
[10.106] Valve drive and gears .....	10.3
[10.101] Cylinder heads .....	10.4
[10.105] Connecting rods and pistons.....	10.5
[10.103] Crankshaft and flywheel.....	10.6
[10.216] Fuel tanks .....	10.7
[10.218] Fuel injection system.....	10.8
[10.202] Air cleaners and lines .....	10.9
[10.250] Turbocharger and lines.....	10.10
[10.254] Intake and exhaust manifolds and muffler .....	10.11
[10.400] Engine cooling system .....	10.12
[10.304] Engine lubrication system.....	10.13
Hydraulic systems.....	35
[35.000] Hydraulic systems.....	35.1
[35.300] Reservoir, cooler, and filters.....	35.2
[35.106] Variable displacement pump .....	35.3
[35.359] Main control valve.....	35.4
[35.355] Hydraulic hand control .....	35.5
[35.356] Hydraulic foot control.....	35.6
[35.352] Hydraulic swing system .....	35.7
[35.353] Hydraulic travel system .....	35.8
[35.354] Hydraulic central joint .....	35.9
[35.736] Boom hydraulic system .....	35.10
[35.737] Dipper hydraulic system.....	35.11

[35.738] Excavator and backhoe bucket hydraulic system .....	35.12
[35.739] Swing arm hydraulic system .....	35.13
[35.741] Dozer blade cylinders .....	35.14
<b>Frames and ballasting .....</b>	<b>39</b>
[39.101] Upper frame .....	39.1
[39.103] Swing ring assembly .....	39.2
[39.140] Ballasts and supports .....	39.3
<b>Tracks and track suspension .....</b>	<b>48</b>
[48.130] Track frame and driving wheels .....	48.1
[48.100] Tracks .....	48.2
[48.134] Track tension units .....	48.3
[48.138] Track rollers .....	48.4
<b>Electrical systems .....</b>	<b>55</b>
[55.000] Electrical system .....	55.1
[55.100] Harnesses and connectors .....	55.2
[55.015] Engine control system .....	55.3
[55.201] Engine starting system .....	55.4
[55.301] Alternator .....	55.5
[55.302] Battery .....	55.6
[55.011] Fuel tank system .....	55.7
[55.013] Engine oil system .....	55.8
[55.404] External lighting .....	55.9
[55.510] Cab or platform harnesses and connectors .....	55.10
<b>Booms, dippers, and buckets .....</b>	<b>84</b>
[84.114] Boom pivoting support .....	84.1
[84.910] Boom .....	84.2
[84.912] Dipper arm .....	84.3
[84.100] Bucket .....	84.4

**<https://www.ebooklibonline.com>**

Hello dear friend!

Thank you very much for reading.

Enter the link into your browser.

The full manual is available for immediate download.

**<https://www.ebooklibonline.com>**

Dozer blade and arm.....	86
[86.110] Dozer blade .....	86.1
Platform, cab, bodywork, and decals.....	90
[90.150] Cab.....	90.1
[90.110] Operator platform less cab .....	90.2
[90.114] Operator protections .....	90.3
[90.105] Machine shields and guards .....	90.4
[90.116] Fenders and guards.....	90.5



## INTRODUCTION

---

## **Foreword - Important notice regarding equipment servicing**

All repair and maintenance work listed in this manual must be carried out only by qualified dealership personnel, strictly complying with the instructions given, and using, whenever possible, the special tools.

Anyone who performs repair and maintenance operations without complying with the procedures provided herein shall be responsible for any subsequent damages.

The manufacturer and all the organizations of its distribution chain, including - without limitation - national, regional, or local dealers, reject any responsibility for damages caused by parts and/or components not approved by the manufacturer, including those used for the servicing or repair of the product manufactured or marketed by the manufacturer. In any case, no warranty is given or attributed on the product manufactured or marketed by the manufacturer in case of damages caused by parts and/or components not approved by the manufacturer.

The information in this manual is up-to-date at the date of the publication. It is the policy of the manufacturer for continuous improvement. Some information could not be updated due to modifications of a technical or commercial type, or changes to the laws and regulations of different countries.

In case of questions, refer to your CASE CONSTRUCTION Sales and Service Networks.

## Safety rules

### Personal safety





This is the safety alert symbol. It is used to alert you to potential personal injury hazards. Obey all safety messages that follow this symbol to avoid possible death or injury.

Throughout this manual you will find the signal words DANGER, WARNING, and CAUTION followed by special instructions. These precautions are intended for the personal safety of you and those working with you.

Read and understand all the safety messages in this manual before you operate or service the machine.

 DANGER indicates a hazardous situation that, if not avoided, will result in death or serious injury.

 WARNING indicates a hazardous situation that, if not avoided, could result in death or serious injury.

 CAUTION indicates a hazardous situation that, if not avoided, could result in minor or moderate injury.

**FAILURE TO FOLLOW DANGER, WARNING, AND CAUTION MESSAGES COULD RESULT IN DEATH OR SERIOUS INJURY.**

### Machine safety

**NOTICE:** Notice indicates a situation that, if not avoided, could result in machine or property damage.

Throughout this manual you will find the signal word Notice followed by special instructions to prevent machine or property damage. The word Notice is used to address practices not related to personal safety.

### Information

**NOTE:** Note indicates additional information that clarifies steps, procedures, or other information in this manual.

Throughout this manual you will find the word Note followed by additional information about a step, procedure, or other information in the manual. The word Note is not intended to address personal safety or property damage.

---

## Personal safety

**NOTICE:** The proper and safe lubrication and maintenance for this machine, recommended by Manufacturer, are outlined in the OPERATOR'S MANUAL for the machine.

Improper performance of lubrication or maintenance procedures are dangerous and could result in injury or death. Read and understand the MANUAL before performing any lubrication or maintenance.

The serviceman or mechanic may be unfamiliar with many of the systems on this machine. This makes a careful use of the systems very important when performing maintenance operations. Sound knowledge of the system and or components is important before the removal or disassembly of any component.

Because of the size of some of the machine components, the serviceman or mechanic should check the weights noted in this manual. Use proper lifting procedures when removing any components. Weight of components table is shown in this section.

The following is a list of basic precautions that must always be observed.

1. Read and understand all Warning plates and decals on the machine before Operating, Maintaining or Repairing this machine.
2. Always wear protective glasses and protective shoes when working around machines. In particular, wear protective glasses when using hammers, punches or drifts on any part of the machine or attachments. Use welders gloves, hood/goggles, apron and the protective clothing appropriate to the welding job being performed. Do not wear loose fitting or torn clothing. Remove all rings from fingers, loose jewellery, confine long hair and loose clothing before working on this machinery.
3. Disconnect the battery and hang a "Maintenance in Progress" tag in the operator's seat. Remove starter key.
4. If possible, make all repairs with the machine parked on a level and firm surface. Block the machine so it does not roll while working on or under the machine. Hang a "Maintenance in Progress" tag in the operator's seat.
5. Do not work on any machine that is supported only by lift, jacks or a hoist. Always use blocks or stops for the jack before carrying out any disassembly operation.

**NOTICE:** Do not operate this machine unless you have read and understood all instructions contained in this manual. Improper machine operation is dangerous and could result in injury or death.

6. Relieve all pressure in air, oil or water systems before any lines, fittings or related items are disconnected or removed. Always make sure all raised components are blocked correctly and be alert for possible pressure when disconnecting any device from a system under pressure.
7. Lower the bucket, dozer or other attachments to the ground before performing any work on the machine. If this cannot be done, make sure the bucket, blade or other attachment is blocked correctly to prevent it from dropping unexpectedly.
8. Use steps and grab handles when mounting or dismounting a machine. Remove any debris or mud from steps, walkways or work platforms before using them. Always face the machine when using steps, ladders and walkways. When it is not possible to use the designed access system, provide ladders, scaffolds, or work, platforms to perform safe repair operations.
9. To avoid back injury, use a hoist when lifting components which weigh 20 kg (44.09 lb) or more. Make sure all chains, hooks, slings, etc., are in good condition and are the correct capacity. Be sure hooks are positioned correctly. Lifting eyes are not to be side loaded during a lifting operation.
10. To avoid burns, be alert for hot parts and surfaces immediately after stopping the machine such as hot fluids in lines, tubes and compartment covers.
11. Be careful when removing cover plates. Gradually back off the last two capscrews or nuts located at opposite ends of the cover or device and carefully pry the cover loose to relieve any spring or other pressure, before removing the last two capscrews or nuts completely.
12. Be careful when removing filler caps, breathers and plugs on the machine. Hold a rag over the cap or plug to prevent being sprayed or splashed by liquids under pressure. Danger is even greater if the machine has just been stopped, as liquids might be boiling hot.
13. Always use the proper tools that are in good condition and that are suited for the job at hand. Be sure you understand how to use them before performing any service work.
14. Reinstall all clamps with the same spare part number. Do not use clamps of inferior quality if replacement is necessary.

## INTRODUCTION

---

15. Repairs which require welding should be performed only with the benefit of the appropriate reference information and by personnel adequately trained and skilled in welding procedures. Determine the type of metal being welded and select the correct welding procedure and electrodes, rods or wires to provide a metal weld strength at least equivalent to that of the parent metal. Make sure to disconnect the battery before any welding operation is performed.
16. Do not damage wiring during removal operations. Reinstall the wiring so it is not damaged nor will be damaged in operation of the machine by contacting sharp corners, or by rubbing against some object or hot surface. Do not connect wiring to a line containing fluid.
17. Be sure all protective devices, including guards and shields, are properly installed and functioning correctly before starting a repair. If a guard or shield must be removed to perform the repair work, use extra caution and replace the guard or shield after repair is complete.
18. Performing maintenance and repair operations while the bucket is lifted is dangerous, because there is the possibility of a device falling. Do not fail to lower such device and place the bucket to the ground before starting the operation.
19. Loose or dirty fuel, lubrication and hydraulic systems, pipes and hoses may cause fires. Do not bend or strike high-pressure lines, do not install bent or damaged lines. Inspect lines, tubes and hoses carefully. Do not check for leaks with your hands. Very small (pinhole) leaks can result in a high velocity oil jet that will be invisible close to the hose.  
This oil can penetrate the skin and cause personal injury. Use card-board or paper to locate pinhole leaks.
20. Tighten connections to the correct torque. Make sure that all protections against burns, the clamps and the operator's protective devices are correctly installed in order to prevent excessive heat, vibrations or rubbing against other parts during operation. Shields that protect against oil spray onto hot exhaust components in event of a line, tube or seal failure must be installed correctly.
21. Do not operate a machine if any rotating part is damaged or contacts any other part during operation. Any high speed rotating component that has been damaged or altered should be checked for balance before reusing.
22. Be careful when servicing or separating the tracks. Chips can fly when removing or installing a track pin. Wear safety glasses and long sleeve protective clothing. Tracks can unroll very quickly when separated. Keep away from front and rear of machine. The machine can move unexpectedly when both tracks (crawlers) are disengaged from the sprockets. Block the machine to prevent it from moving.

## Part identification

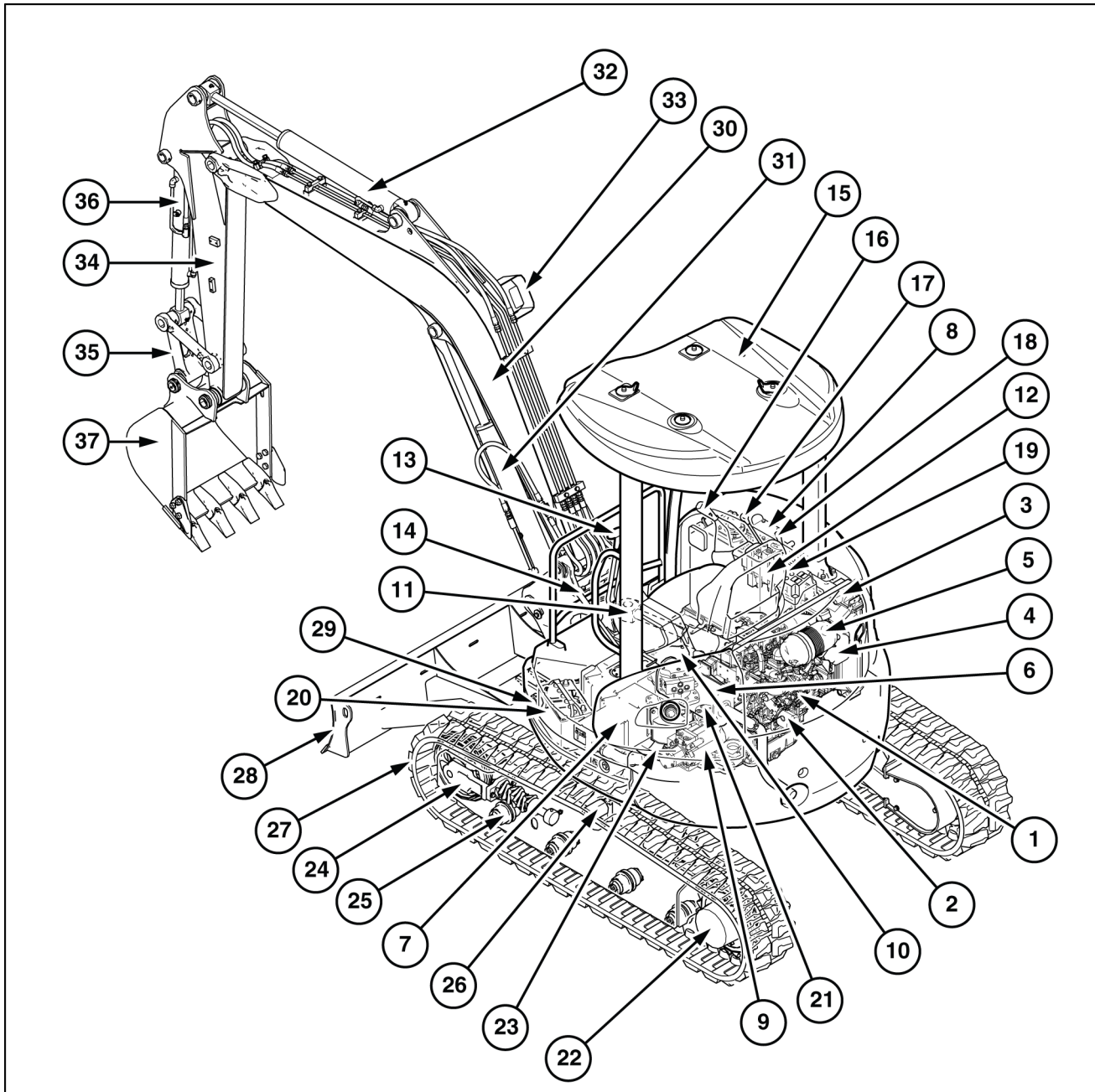

TUL112EXN6006GB 1

- |                       |                         |                     |
|-----------------------|-------------------------|---------------------|
| 1. Engine             | 14. Safety lever        | 27. Rubber crawler  |
| 2. Oil filter         | 15. Canopy              | 28. Dozer           |
| 3. Radiator           | 16. Operating lever     | 29. Dozer cylinder  |
| 4. Reservoir tank     | 17. Dozer control lever | 30. Boom            |
| 5. Air cleaner        | 18. Throttle lever      | 31. Boom cylinder   |
| 6. Muffler            | 19. Gauge cluster       | 32. Arm cylinder    |
| 7. Fuel tank          | 20. Battery             | 33. Light           |
| 8. Hydraulic oil tank | 21. Swivel joint        | 34. Arm             |
| 9. Hydraulic pumps    | 22. Travel motor        | 35. Link            |
| 10. Slewing motor     | 23. Slewing ring        | 36. Bucket cylinder |
| 11. Swing cylinder    | 24. Idler adjuster      | 37. Bucket          |
| 12. Control valve     | 25. Lower roller        |                     |
| 13. Travel lever      | 26. Upper roller        |                     |



# **SERVICE MANUAL**

**Engine**

**CX26B  
CX30B**

## Engine - External view

1. Filler port (engine oil)
2. Turbocharger
3. Air intake port (from air cleaner, optional)
4. Lifting eye
5. Coolant pump
6. Fan
7. Crankshaft V-pulley
8. V-belt
9. Filler port (engine oil)
10. Drain plug (engine oil)
11. Engine oil cooler (4TNV98T, 4TNV106 and 4TNV106T)
12. Engine oil filter
13. Dipstick (engine oil)
14. Fuel injection pump
15. Governor lever
16. Fuel filter
17. Fuel cock
18. Fuel filter mounting
19. Lifting eye
20. Engine name plate
21. Rocker arm cover
22. Flywheel
23. Starter motor
24. Exhaust manifold
25. Generator

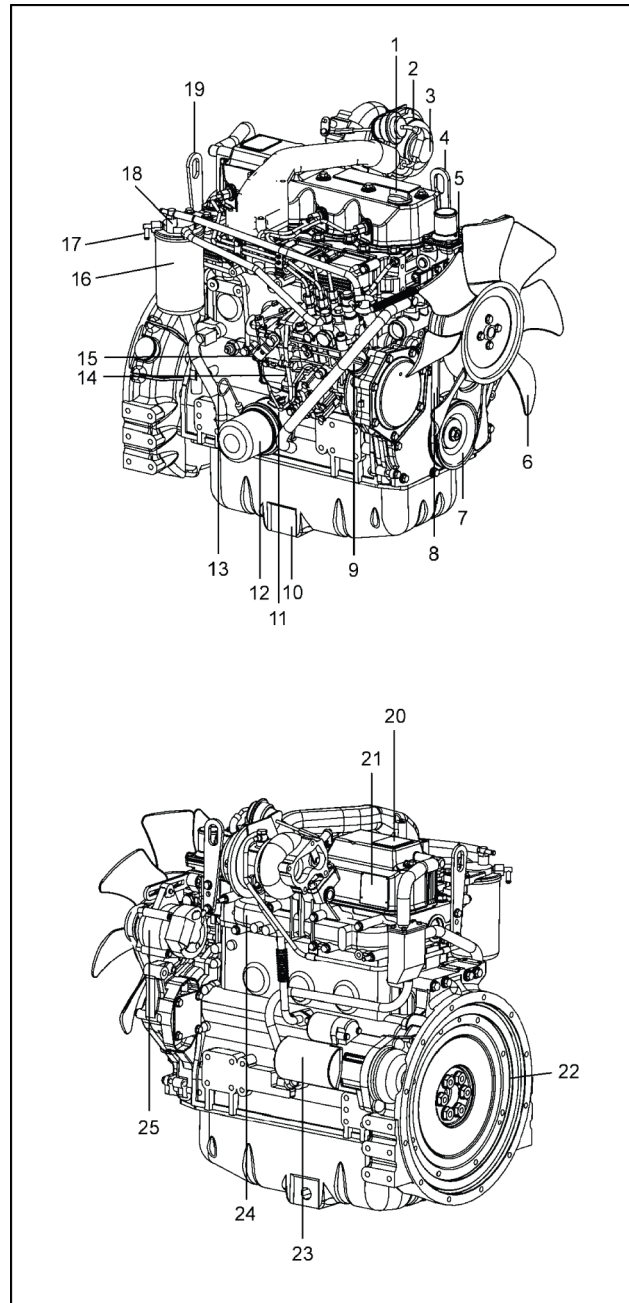

TUL112EXN4782CA 1

**NOTE:** This illustration shows the 4TNV98T engine (with turbocharger).

The drain plug (engine oil) location depends on the engine installed on the machine unit to be on the fuel injection pump side (above illustration) or starter motor side.

## Engine - Static description

### 1. Emission reduction

New fuel injection pressure

- Mono plunger
- Higher injection pressure
- Injection timing, speed timer, load timer, cold start timer control

### 2. Noise reduction

Higher stiffness cylinder block

Higher stiffness gear-case

### 3. Emission reduction

Injection nozzle

- Low suck volume
- Multi injection holes

### 4. Emission reduction

Cylinder head

- Optimal nozzle angle
- Optimal swirl ratio
- Optional valve timing

### 5. Emission reduction

Piston

- New combustion chamber

### Noise reduction

New lube oil pan

- Change rotor shape for low pulsation
- Driven by crankshaft directly

### 6. Emission reduction

Cylinder head

- 4 valve/cylinder (intake-2, exhaust-2)
- Optimal installation of the injection nozzle vertical installation and location of the centre of cylinder
- Optimal valve timing

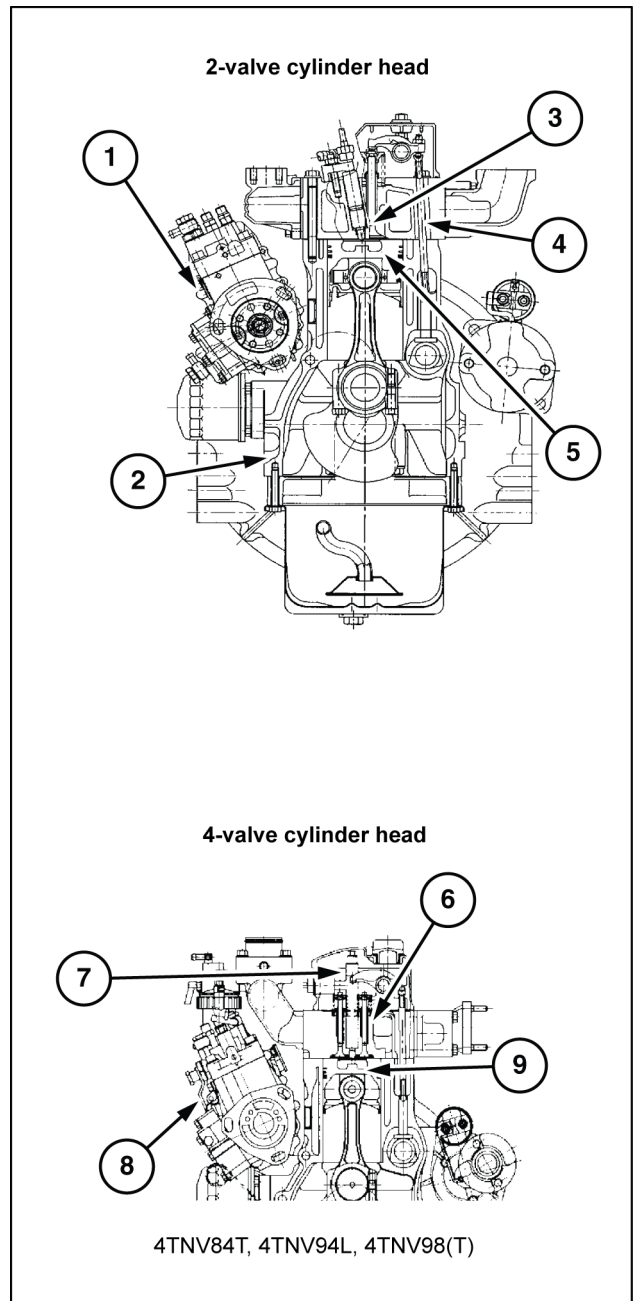

TUL112EXN4783CB 1

## **7. Emission reduction**

New fuel injection nozzle

- Low suck volume
- Multi injection holes

## **8. Emission reduction**

New fuel injection pump

- Mono plunger
- Higher injection pressure
- Mechanical control of injection timing, speed timer, load timer, cold start timer

## **9. Emission reduction**

Piston

- New combustion chamber

## **Noise reduction (only applied for 4TNV84T)**

New lube oil pan

- Change rotor shape for low pulsation
- Driven by crankshaft directly

## Engine - Service instruction

### Periodic maintenance schedule

The engine periodic inspection timing is hard to determine as it varies with the application, load status, qualities of the fuel and lubricating oils used and handling status. General rules are described here.

- : User-maintenance
- : Parts replacement
- : Shop-inspection

Classification	Piece	Daily	Maintenance period				
			Every 50 h	Every 250 h or 3 months	Every 500 h or 6 months	Inspection every 1000 h or one year	Every 2000 h or two years
Whole	Visual check around the machine	○					
Fuel system	Fuel tank level check and fuel supply	○					
	Fuel tank drain		○				
	Water separator (Option) draining	○					
	Fuel system bleeding		○				
	Water separator cleaning			○			
	Fuel filter element replacement					■	
Lubricating oil system	Lube oil level check and replenishment	○					
	Lube oil replacement						
	Lube oil filter replacement		■ 1st time	■ 2nd time and thereafter			
Coolant pump	Coolant level check and replenishment	○					
	Radiator fin cleaning			○			
	V-belt tension check		○ 1st time	○ 2nd time and thereafter			
	Coolant change					■	
	Coolant/water path flushing and maintenance						●
Rubber hose	Fuel pipe and coolant pipe inspection and maintenance	○					●
Injection governor	Inspection and adjustment of governor lever and accelerator	○		○			

Engine - Engine and crankcase

Classification	Piece	Daily	Maintenance period				
			Every 50 h	Every 250 h or 3 months	Every 500 h or 6 months	Inspection every 1000 h or one year	Every 2000 h or two years
Air intake system	Air cleaner cleaning and element replacement			○	■		
	Diaphragm assy inspection					● (2 years)	
	Turbocharger blower cleaning*					●*	
Electrical system	Warning lamp and instruments function check	○					
	Battery electrolyte level check and battery recharging		○				
Cylinder head	Intake/exhaust valve head clearance adjustment					●	
	Intake/exhaust valve seat lapping						●
Fuel injection pump and nozzle	Fuel injection nozzle pressure inspection					●*	
	Fuel injection timing adjustment Fuel injection pump inspection and adjustment						●*

\*EPA allows servicing the emission related parts every  
**1500 - 3000 h**

---

## Engine - Inspect - Daily Inspection

Be sure to check the following points before starting an engine every day:

No.	Inspection item
1.	Visual check around the machine
2.	Fuel tank level check and fuel supply
3.	Lube oil level check and replenishment
4.	Coolant level check and replenishment
5.	Fuel pipe and coolant pipe inspection and maintenance
6.	Inspection and adjustment of governor lever and accelerator
7.	Warning lamp and instruments function check
8.	Water separator draining

### Visual check around the machine

If any problem is found, do not use before the engine repairs have been completed.

- Oil leak from the lubrication system
- Fuel leak from the fuel system
- Coolant leak from the water cooling system
- Damaged parts
- Loosened or lost screws
- Fuel, radiator rubber hoses, cracked V-belt, loosened clamp

### Fuel tank level check and fuel supply

Check the remaining fuel oil level in the fuel tank and refuel the recommended fuel if necessary.

## Lube oil level check and replenishment

### (a) Checking oil level

Check the lubricating oil level with the dipstick **(A)**, after adjusting the position of the machine so that the engine is horizontal. Insert the dipstick fully and check the oil level. The oil shall not be contaminated heavily and have appropriate viscosity.

No coolant water or diesel fuel shall be mixed.

When lube oil is supplied after the engine has been running, check the lube oil level after about **10 min** after the engine shutdown so that the lube oil has filled the oil pan.

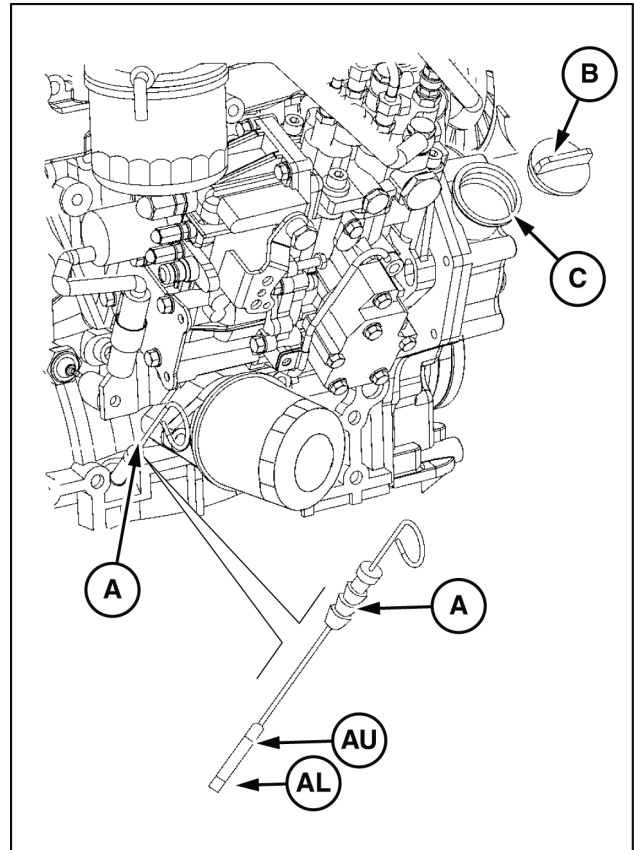

TULI12EXN4788BB 1

The level shall be between the upper **(AU)** and lower **(AL)** limit lines on the dipstick **(A)**.

Model	Total volume	Effective volume
3TNV82A	5.5 l (1.45 US gal)	1.9 l (0.50 US gal)
3TNV84(T) 88	6.7 l (1.77 US gal)	2.8 l (0.74 US gal)
4TNV84(T) 88	7.4 l (1.95 US gal)	3.4 l (0.90 US gal)
4TNV94L98(T)	10.5 l (2.77 US gal)	4.5 l (1.19 US gal)
4TNV106(T) (CL class)	14.0 l (3.70 US gal)	9.0 l (2.38 US gal)
4TNV106(T) (VM class)	14.0 l (3.70 US gal)	7.5 l (1.98 US gal)

Lube oil capacity may differ from the above volume depending on an engine installed on a machine unit.

### (b) Replenishing oil pan with lube oil

If the remaining engine oil level is low, remove the filler port cap **(B)** and fill the oil pan with the specified engine oil to the specified level through the filler port **(C)**.

**NOTE:** The oil should not be overfilled to exceed the upper limit line. Otherwise a naturally-aspirated engine may intake lube oil in the combustion chamber during the operation, then white smoke, oil hummer or urgent rotation may occur, because the blow-by gas is reduced in the suction air flow. In case of turbocharged engine oil may jet out from the breather or the engine may become faulty.

## Coolant check

Daily inspection of coolant water should be done only by coolant recovery tank.

**NOTICE:** Never open the radiator filler cap (R) while the engine and radiator are still hot. Steam and hot water will spurt out and seriously burn you. Wait until the radiator is cooled down after the engine has stopped, wrap the filler cap with a rag piece and turn the cap slowly to gently release the pressure inside the radiator. Securely tighten the filler port plug (R) after checking the radiator. Steam can spurt out during engine running, if tightening loose.

### (a) Checking coolant water volume

Check the coolant level in the expansion tank (C). If the water level is close to the LOW mark, open the coolant expansion tank plug (H) and replenish the tank with soft clean water up to the FULL mark.

The level shall be between the upper and lower limit lines on the dipstick.

### (b) Replenishing radiator with water

If the coolant recovery tank water level is lower than the LOW mark, open the radiator cap (R) and check the coolant water level in the radiator.

Replenish the radiator with coolant, if the level is low.

- Check the coolant level while the engine is cool. Checking when the engine is hot is dangerous. And the water volume is expanded due to the heat.
- Daily coolant level check and replenishing shall be done only from the expansion tank. Usually do not open the radiator cap to check or replenish.

T. Tighten

L. Loosen

**NOTICE:** If the coolant water runs short quickly or when the radiator runs short of water with the coolant expansion tank level unchanged, water may be leaking or the air tightness may be lost. Increase in the coolant expansion tank water level during operation is not abnormal. The increased water in the coolant expansion tank returns to the radiator when the engine is cooled down. If the water level is normal in the coolant expansion tank but low in the radiator, check loosened clamping of the rubber hose between the radiator and coolant recovery tank or tear in the hose.

Engine: The radiator shall be filled up.

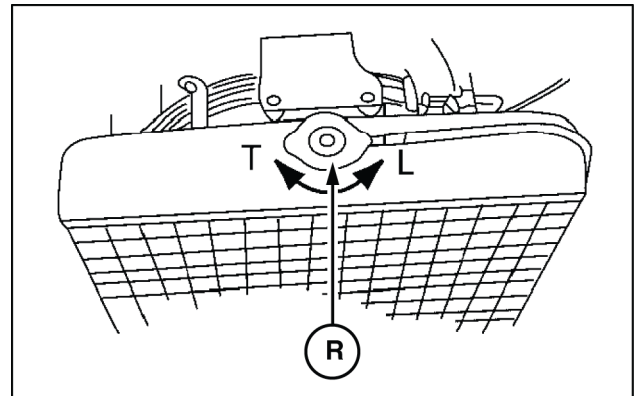

TULI12EXN4789AB 2

Model	Coolant water volume in an engine
3TNV82A	1.8 l (0.48 US gal)
3TNV84(T) 3TNV88	2.0 l (0.53 US gal)
4TNV84(T) 4TNV88	2.7 l (0.71 US gal)
4TNV94L 4TNV98(T)	4.2 l (1.11 US gal)
4TNV106(T)	6.0 l (1.59 US gal)

Engine coolant water capacity may differ from the above volume depending on an engine installed on a machine unit.

## Fuel pipe and coolant pipe inspection and maintenance

Check the rubber hoses for fuel and coolant water pipes cracked.

If the cracked hose is found, replace it with new one.

Check the loosened clamp.

If found, tighten it.

## Inspection and adjustment of governor lever and accelerator

Make sure the accelerator of the machine unit can be operated smoothly before starting the engine. If it feels heavy to manipulate, lubricate the accelerator cable joints and pivots. Adjust the accelerator cable if there is a dislocation or excessive play between the accelerator and the governor lever. Refer to **Engine - Inspect – Every 250 hours or 3 months (10.001)** .

## Warning lamp and instruments function check

Before and after starting the engine, check to see that the alarm function normally. Failure of alarm cannot warn the lack of the engine oil or the coolant water. Make it a rule to check the alarm operation before and after starting engine every day. Refer to each manual for machine units in details.

## Water separator draining

Drain off the water separator (**W**) whenever there is a lot of drain collected in the water separator at the bottom of the cup (**C**) even if the time for periodic inspection has not elapsed yet. The cup of the water separator (**C**) is made of semi-transparent material and, in the cup itself, the red colored floating ring (**FR**) which rises on the surface of the drain is installed to visualize the amount of drain. A level sensor connected to a warning device on the gauge cluster is provided as optional device.

Drain off the water separator in the following manner:

1. Prepare a waste oil container collecting waste oil.
2. Close the fuel cock (**FC**).
3. Loosen the drain cock (**DC**) at the bottom of the water separator, and drain off any water collected inside.
4. Tighten the drain cock (**DC**) manually.
5. Air bleeding from fuel system.

**NOTE:** If no drain drips when the drain cock is opened, loosen the air bleeding bolt (**A**) on the top of the water separator by turning counterclockwise 2 - 3 times using screwdriver. (This may occur in case of the water separator position is higher than the fuel oil level in the fuel tank). After draining, be sure to tighten the air bleeding bolt (**A**).

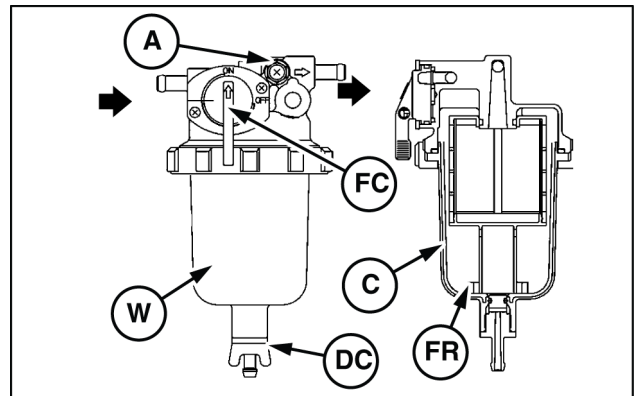

TULI12EXN4795AB 3

## Inspection after initial 50 h operation

Be sure to check the following points after initial **50 h** operation, thereafter every **250 h** or 3 months operation.

No.	Inspection item
1.	Lube oil and filter replacement
2.	V-belt tension check

### 1. Lubricating oil change and filter replacement (1<sup>st</sup> time)

**NOTICE:** When an engine is still hot, be careful with a splash of engine oil which may cause burns. Replace engine oil after the engine oil becomes warm.

It is most effective to drain the engine oil while the engine is still warm.

In early period of use, the engine oil gets dirty rapidly because of the initial wear of internal parts. Replace the engine oil earlier. Lube oil filter should also be replaced when the engine oil is replaced. The procedure of lube oil and lube oil filter replacement is as follows:

#### A. Drain engine oil

- Prepare a waste oil container collecting waste oil.
- Remove the oil filler cap to drain easily while draining the lube oil.
- Loosen the drain plug (DP) using a wrench (customer procured) to drain the lube oil.
- Securely tighten the drain plug after draining the lube oil.
- DP. Drain plug. The location depends on the engine installed on the machine unit.

**NOTE:** Use a socket wrench or a closed wrench when removing or tightening a drain plug. Do not use a spanner because there is the possibility that the spanner slips and you get hurt.

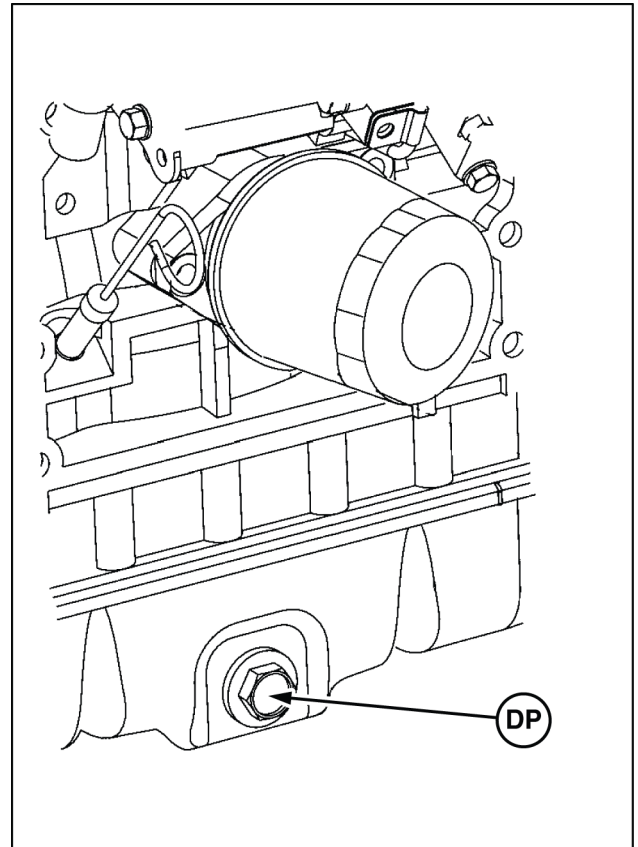

TULI12EXN4790BB 4

B. Replacing oil filter

- Turn the lube oil filter (**E**) counterclockwise using a filter wrench (customer procured) to remove it.
- Clean the mounting face of the oil filter.
- Moisten the new oil filter gasket with the engine oil and install the new engine oil filter manually turning it clockwise until it comes into contact with the mounting surface, and tighten it further to 3/4 of a turn with the filter wrench.

Tightening torque: **20 - 24 N·m (15 - 18 lb ft)**

C. Oil filling and inspection

- Fill with new engine oil until it reaches the specified level.

**NOTICE:** Do not overfill the oil pan (**O**) with engine oil. Be sure to keep the specified level between upper and lower limit on the dipstick (**D**).

T. Tighten

L. Loosen

- Warm up the engine by running for **5 min** while checking any oil leakage.
- Stop the engine after warming up and leave it stopping for about **10 min** to recheck the engine oil level with dipstick and replenish the engine oil. If any oil is spilled, wipe it away with a clean cloth.

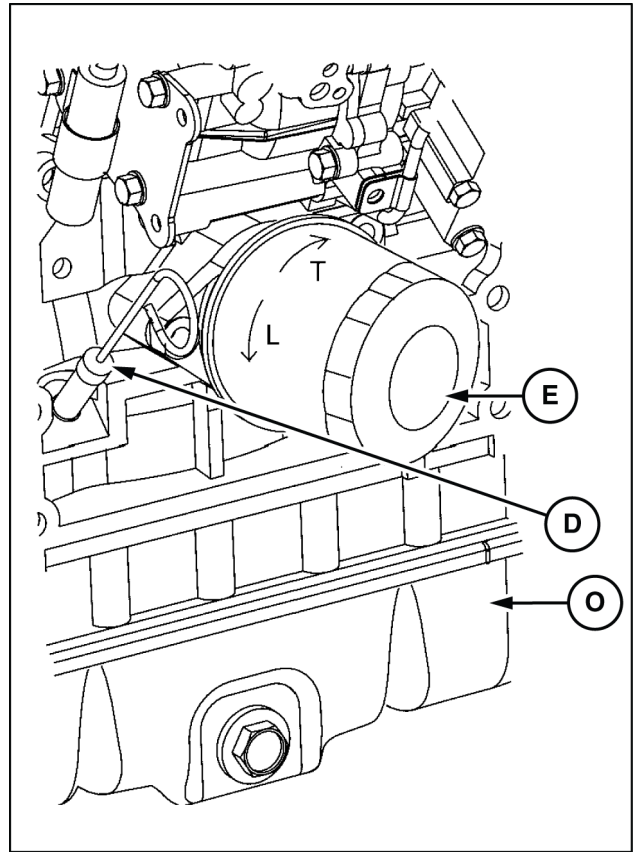

TULI12EXN4791BB 5

2. V-belt tension check

When there is not enough tension in the V-belt (**V**), the V-belt will slip making it impossible for the alternator (**A**) to generate power and cooling water pump and cooling fan (**R**) will not work causing the engine to overheat. Check and adjust the V-belt tension (deflection) in the following manner:

**NOTE:** Be especially careful not to splash engine oil on the V-belt, because it will cause slipping, stretching and aging of the belt.

1. Press the V-belt with your thumb [approximately **98 N (22 lb)**] in the middle of the V-belt span to check the tension (deflection).

Available positions to check and adjust the V-belt tension (deflection) are at the A, B or C direction as shown in the Fig. 6.

You may choose a position whichever you can easily carry out the check and adjustment on the machine unit.

- “New V-belt” refers to a V-belt which has been used less than **5 min** on a running engine.
- “Used V-belt” refers to a V-belt which has been used on a running engine for **5 min** or more. The specified deflection to be measured at each position should be as follows:

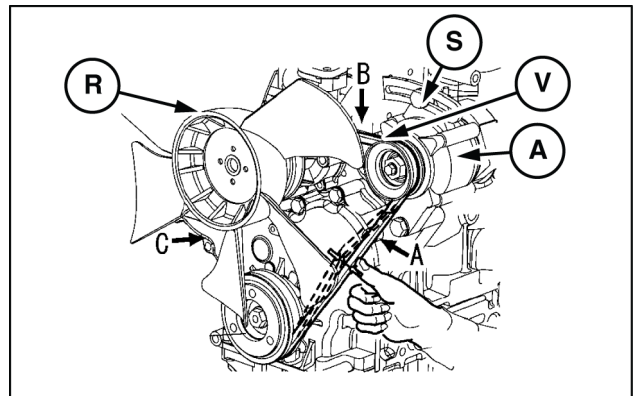

TULI12EXN4792AB 6

Direction	A	B	C
For used V-belt	10 - 14 mm (0.39 - 0.55 in)	7 - 10 mm (0.28 - 0.39 in)	9 - 13 mm (0.35 - 0.51 in)
For new V-belt	8 - 12 mm (0.31 - 0.47 in)	5 - 8 mm (0.20 - 0.31 in)	7 - 11 mm (0.28 - 0.43 in)

2. If necessary, adjust the V-belt tension (deflection). To adjust the V-belt tension, loosen the setscrew (**S**) and move the alternator (**A**) to tighten the V-belt. (Adjust the V-belt tension inserting a bar (**AV**)). After replacing with a new V-belt and adjusting it, run the engine for **5 min** and readjust the deflection to the value in the table above.
3. After replacing with a new V-belt and adjusting it, run the engine for **5 min** and readjust the deflection to the value in the table above.
4. Visually check the V-belt for cracks, oiliness or wear. If any, replace the V-belt with new one.

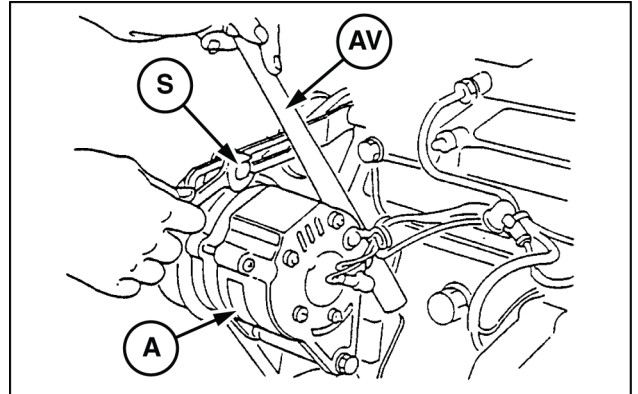

TULI12EXN4793AB 7



**Suggest:**

**If the above button click is invalid.**

**Please download this document**

**first, and then click the above link**

**to download the complete manual.**

**Thank you so much for reading**

## Engine - Inspect – Every 50 hours

Be sure to check the following points before starting an engine every day.

No.	Inspection item
1.	Fuel tank drain
2.	Fuel system bleeding
3.	Battery electrolyte level check and battery recharging

### Fuel tank drain

1. Prepare a waste oil container collecting waste oil.
2. Remove the drain plug (**D**) of the fuel tank (**F**) to drain (water, dust, etc.) from the fuel tank bottom.
3. Drain until fuel with no water and dust flow out. Then tighten the drain plug firmly.

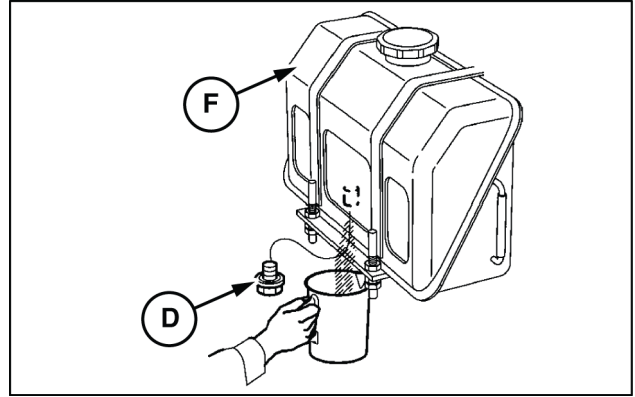

TULI12EXN4794AB 1

### Fuel system bleeding

Bleed the fuel system according to the following procedures. When there is air in the fuel system, the fuel injection pump (**FI**) will not be able to operate.

1. Check the fuel oil level in the fuel tank. Refuel if insufficient.
2. Open the cock (**FC**) of the water separator (**W**).
3. Loosen the air bleeding bolt (**A**) on the water separator by turning counterclockwise 2 -3 times using a screwdriver or a spanner.
4. When the fuel coming out is clear and not mixed with any bubble, tighten the air bleeding bolt (**A**).
5. Feed fuel with the fuel priming pump (**FP**) or electro-magnetic fuel feed pump.

- In case the engine uses the electro-magnetic fuel feed pump.  
Turn the starter switch to the "ON" position and hold it in the position for **10 - 15 s** to operate the fuel feed pump.

- In case the engine uses the electro-magnetic fuel feed pump (**FP**).  
The priming pump is on the top of the fuel filter mounting. Move the priming pump up and down to feed fuel until feel your hand slightly heavy.

- Water separator (**W**)  
(Installed on the pipe line)
- Fuel filter (**FF**)  
(Mounting with fuel priming pump) (option)

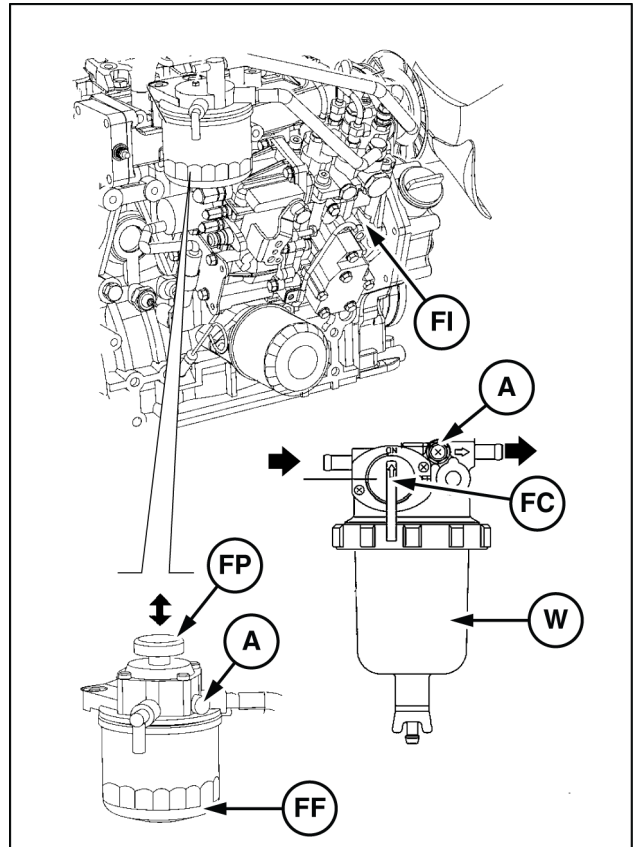

TULI12EXN4796BB 2

**<https://www.ebooklibonline.com>**

Hello dear friend!

Thank you very much for reading.

Enter the link into your browser.

The full manual is available for immediate download.

**<https://www.ebooklibonline.com>**