

# 9060B Excavator Service Manual No. 7-65272

## Table of Contents

Description	Section No.	Form No.
<b>General</b>		
	<b>Tab 1</b>	
Loctite Product Chart		8-98900
Safety, General Information and Torque Specifications	1001	7-62010
Specifications	1002	7-65330
<b>Engines</b>		
	<b>Tab 2</b>	
Engine - Mitsubishi	2000	7-65380
Engine - Cummins	2000	7-51980
Radiator, Oil Cooler and Cooling System Reservoir - Mitsubishi Engine	2001	7-65390
Radiator, Oil Cooler and Cooling System Reservoir - Cummins Engine	2001	7-51990
<b>Fuel System</b>		
	<b>Tab 3</b>	
Fuel Tank, Filters and Lines - Mitsubishi Engine	3001	7-65450
Fuel Tank, Filters and Lines - Cummins Engine	3001	7-52000
<b>Electrical</b>		
	<b>Tab 4</b>	
Electrical Specifications and Troubleshooting	4001	7-65310
Electrical Schematic Foldout	In Rear Pocket	7-15330
Battery Testing, Maintenance and Booster Battery Connections	4002	7-64500
Controller	4003	7-62070
<b>Tracks</b>		
	<b>Tab 5</b>	
Tracks, Rollers and Idlers	5002	7-65340
<b>Power Train</b>		
	<b>Tab 6</b>	
Drive Motor and Final Drive Transmission	6002	7-65370
Swing Motor and Swing Reduction Gear	6003	7-65460
<b>Hydraulics</b>		
	<b>Tab 8</b>	
Cleaning the Hydraulic System	8000	7-64510
Hydraulic Specifications, Troubleshooting and Pressure Checks	8001	7-65321
Hydraulic Schematic Foldout	In Rear Pocket	7-15330
Main Hydraulic Pump	8002	7-63660
Main Hydraulic Control Valve	8003	7-65360
Cylinders	8004	7-65480

Reprinted

**CASE CORPORATION**  
700 STATE STREET  
RACINE, WI 53404 U.S.A.

**CASE CANADA CORPORATION**  
450 SHERMAN AVENUE  
HAMILTON, ON L8N 4C4

Bur 7-52711

Copyright © 1999 Case Corporation  
Printed in U.S.A.  
Issued April 1999

# 9060B Excavator Service Manual No. 7-65272

## Table of Contents

Description	Section No.	Form No.
Hand Control Valves, Foot Left and Right Travel Control Valves, Shuttle Valve and Accumulator	8005	7-64520
Eight Spool Solenoid Valve, Swing Lock and Swing Brake Solenoid Valve	8006	7-64530
Cushion Control Valve	8007	7-64540
Auxiliary Hydraulics	8008	7-62180
Hydraulic Reservoir Pressurization System	8009	7-64710
Oil Cooler and Fan Drive Motor Hydraulic Pump - Cummins Engine	8010	7-51970
Hydraulic Pilot Filter, Hydraulic Inline Filter and Bypass Oil Filter	8011	7-65490
Hydraulic Swivel	8013	7-65500
<b>Mounted Equipment</b>	<b>Tab 9</b>	
Upper Structure Counterweight	9002	7-64720
Boom, Arm and Bucket	9003	7-64730
Operators Seat, Operators Seat Bracket and Seat Belts	9004	7-62260
Cab and Cab Equipment	9005	7-62270
Air Conditioner Troubleshooting and System Checks	9006	7-62280
Air Conditioner Components Removal and Installation	9008	7-62300
Air Conditioner Components	9009	7-62310

# Section 1001

## SAFETY, GENERAL INFORMATION AND TORQUE SPECIFICATIONS

**<https://www.ebooklibonline.com>**

Hello dear friend!

Thank you very much for reading.

Enter the link into your browser.

The full manual is available for immediate download.

**<https://www.ebooklibonline.com>**

# SAFETY

 *This symbol means ATTENTION! BECOME ALERT! YOUR SAFETY IS INVOLVED. The message that follows the symbol contains important information about safety. Carefully read the message. Make sure you fully understand the causes of possible injury or death.* SB001

To prevent injury always follow the Warning, Caution and Danger notes in this section and throughout the manual.

Put the warning tag shown below on the key for the keyswitch when servicing or repairing the machine. One warning tag is supplied with each machine. Additional tags Part Number 331-4614 are available from your service parts supplier.

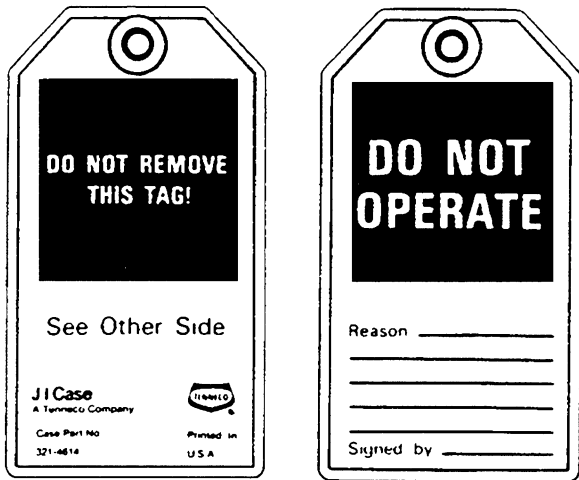



1001-01

 **WARNING:** Read the operator's manual to familiarize yourself with the correct control functions. 46-27

 **WARNING:** Operate the machine and equipment controls from the seat position only. Any other method could result in serious injury. 48-55

 **WARNING:** This is a one man machine, no riders allowed. 35-8

 **WARNING:** Before starting engine, study Operator's Manual safety messages. Read all safety signs on machine. Clear the area of other persons. Learn and practice safe use of controls before operating. It is your responsibility to understand and follow manufacturers instructions on machine operation, service and to observe pertinent laws and regulations. Operator's and Service Manuals may be obtained from your Case dealer. SA055

 **WARNING:** If you wear clothing that is too loose or do not use the correct safety equipment for your job, you can be injured. Always wear clothing that will not catch on objects. Extra safety equipment that can be required includes hard hat, safety shoes, ear protection, eye or face protection, heavy gloves and reflector clothing. 45-3A

 **WARNING:** When working in the area of the fan belt with the engine running, avoid loose clothing if possible, and use extreme caution. 35-4

 **WARNING:** When doing checks and tests on the equipment hydraulics, follow the procedures as they are written. DO NOT change the procedure. 47-44

 **WARNING:** When putting the hydraulic cylinders on this machine through the necessary cycles to check operation or to remove air from a circuit, make sure all people are out of the way. 47-45



**WARNING:** Use insulated gloves or mittens when working with hot parts. 47-41A



**CAUTION:** Lower all attachments to the ground or use stands to safely support the attachments before you do any maintenance or service. 49-11



**CAUTION:** Pin sized and smaller streams of hydraulic oil under pressure can penetrate the skin and result in serious infection. If hydraulic oil under pressure does penetrate the skin, seek medical treatment immediately. Maintain all hoses and tubes in good condition. Make sure all connections are tight. Make a replacement of any tube or hose that is damaged or thought to be damaged. **DO NOT** use your hand to check for leaks, use a piece of cardboard or wood. 40-6A



**CAUTION:** When removing hardened pins such as a pivot pin, or a hardened shaft, use a soft head (brass or bronze) hammer or use a driver made from brass or bronze and a steel head hammer. 46-17



**CAUTION:** When using a hammer to remove and install pivot pins or separate parts using compressed air or using a grinder, wear eye protection that completely encloses the eyes (approved goggles or other approved eye protectors). 46-13



**CAUTION:** Use suitable floor (service) jacks or chain hoist to raise wheels or tracks off the floor. Always block machine in place with suitable safety stands. 40-7A



**CAUTION:** When servicing or repairing the machine, keep the shop floor and operator's compartment and steps free of oil, water, grease, tools, etc. Use an oil absorbing material and/or shop cloths as required. Use safe practices at all times. 40-8



**CAUTION:** Some components of this machine are very heavy. Use suitable lifting equipment or additional help as instructed in this Service Manual. 40-10



**DANGER:** Engine exhaust fumes can cause death. If it is necessary to start the engine in a closed place, remove the exhaust fumes from the area with an exhaust pipe extension. Open the doors and get outside air into the area. 48-56



**WARNING:** When the battery electrolyte is frozen, the battery can explode if (1), you try to charge the battery, or (2), you try to jump start and run the engine. To prevent the battery electrolyte from freezing, try to keep the battery at full charge. If you do not follow these instructions, you or others in the area can be injured. SA033

## GENERAL INFORMATION

### CLEANING

Clean all metal parts except bearings, in a suitable cleaning solvent or by steam cleaning. Do not use caustic soda for steam cleaning. After cleaning, dry and put oil on all parts. Clean oil passages with compressed air. Clean bearings in a suitable cleaning solvent, dry the bearings completely and put oil on the bearings.

### INSPECTION

Check all parts when the parts are disassembled. Replace all parts that have wear or damage. Small scoring or grooves can be removed with a hone or crocus cloth. Complete a visual inspection for indications of wear, pitting and the replacement of parts necessary to prevent early failures.

### BEARINGS

Check bearings for easy action. If bearings have a loose fit or rough action replace the bearing. Wash bearings with a suitable cleaning solvent and permit to air dry. **DO NOT DRY BEARINGS WITH COMPRESSED AIR.**

### NEEDLE BEARINGS

Before you press needle bearings in a bore always remove any metal protrusions in the bore or edge of the bore. Before you press bearings into position put petroleum jelly on the inside and outside diameter of the bearings.

### GEARS

Check all gears for wear and damage. Replace gears that have wear or damage.

### OIL SEALS, O-RINGS AND GASKETS

Always install new oil seals, O-rings and gaskets. Put petroleum jelly on seals and O-rings.

### SHAFTS

Check all shafts that have wear or damage. Check the bearing and oil seal surfaces of the shafts for damage.

### SERVICE PARTS

Always install genuine Case service parts. When ordering refer to the Parts Catalog for the correct part number of the genuine Case replacement items. Failures due to the use of other than genuine Case replacement parts are not covered by warranty.

### LUBRICATION

Only use the oils and lubricants specified in the Operator's or Service Manuals. Failures due to the use of non-specified oils and lubricants are not covered by warranty.

# Section 2000

2000

## ENGINE

# ENGINE

## Removal

**NOTE:** Make sure engine is cool before starting removal procedures.

### STEP 1

Remove the hydraulic pump (see Section 8002).

### STEP 2

Remove the radiator, oil cooler, and the cooling system reservoir (see Section 2001).

### STEP 3

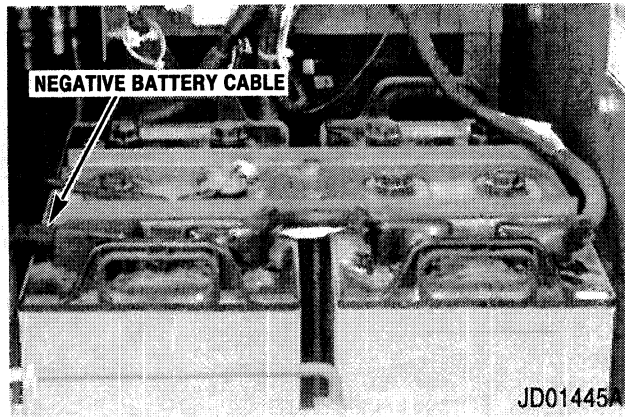

Open the left side access doors. Disconnect the negative battery cable from the battery.

### STEP 4

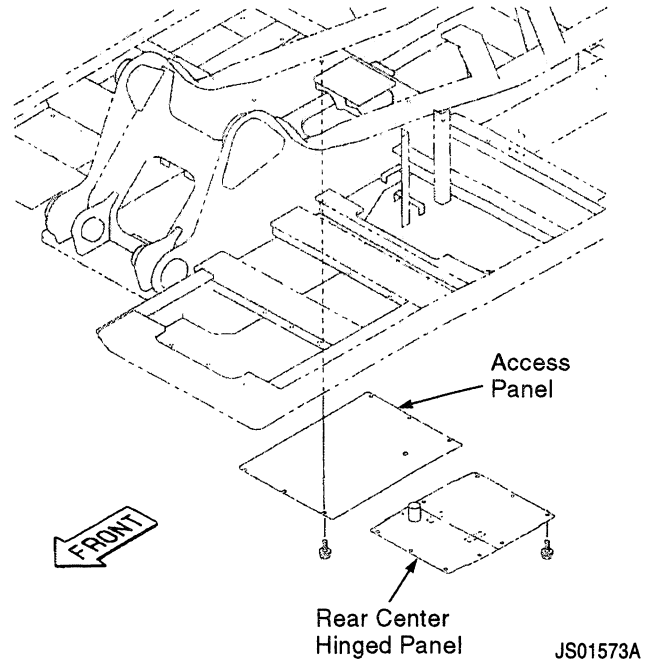

Remove the bottom right rear access panel. Remove the five cap screws securing the rear center hinged panel below the engine. Swing the panel down for access to the engine two left mounts.

### STEP 5

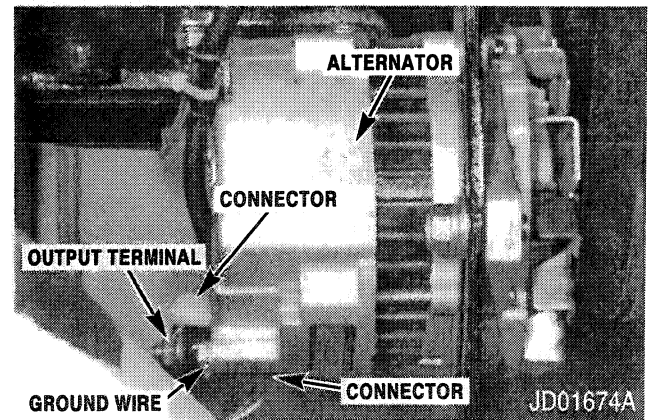

Tag and disconnect the two wiring harness connectors and the ground wire from the alternator. Tag and disconnect the wiring harness wire connected to the alternator output terminal.

### STEP 6

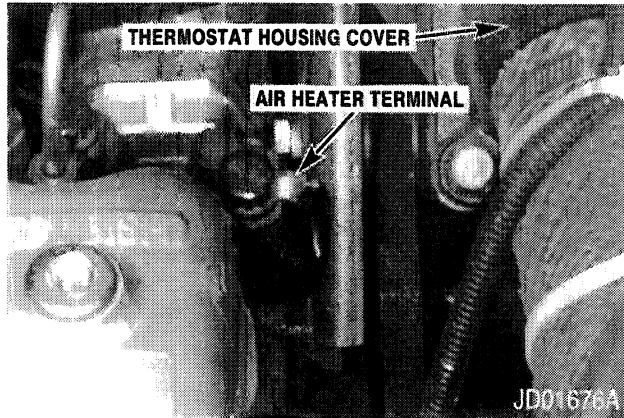

Tag and disconnect the wiring harness wire from the air heater terminal.

### STEP 7

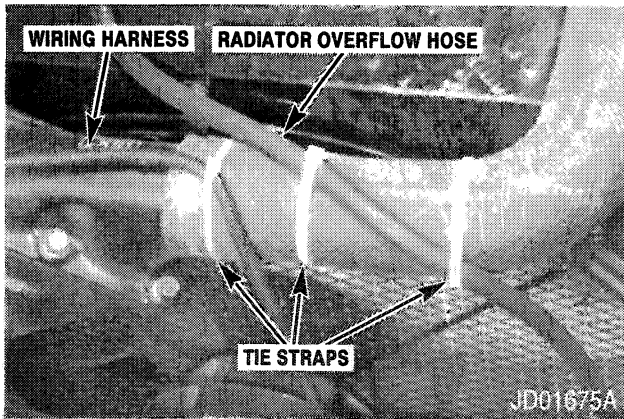

Cut, remove, and discard the three tie straps holding the wiring harness and the radiator overflow hose to the radiator hose.

### STEP 8

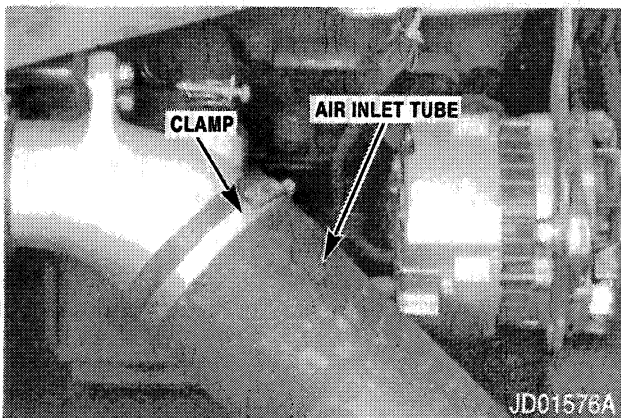

Loosen the clamp securing the air inlet tube to the turbocharger. Disconnect the air inlet tube.

### STEP 9

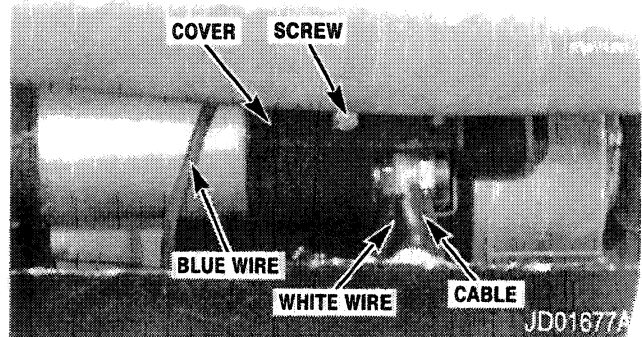

Remove the screw, flat washer, and lock washer and remove the cover. Tag and disconnect the wiring harness blue wire from the starter assembly terminal. Tag and disconnect the wiring harness white wire and the cable from the starter assembly.

### STEP 10

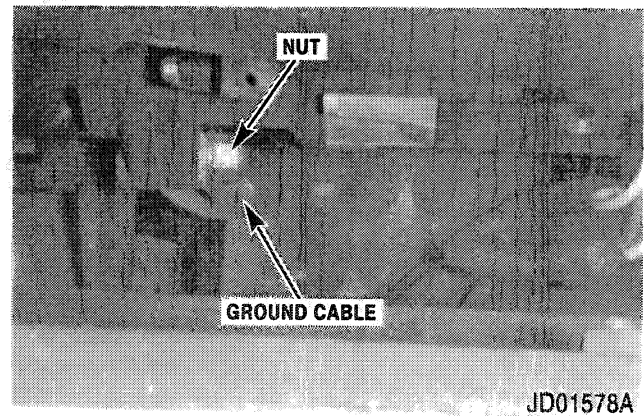

Remove the nut and lock washer. Disconnect the ground cable from the engine.

**STEP 11**

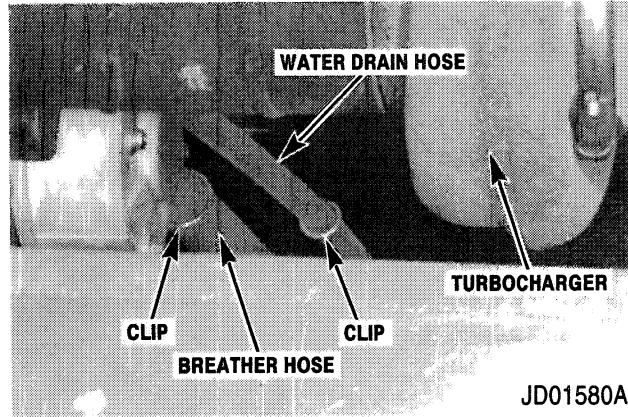
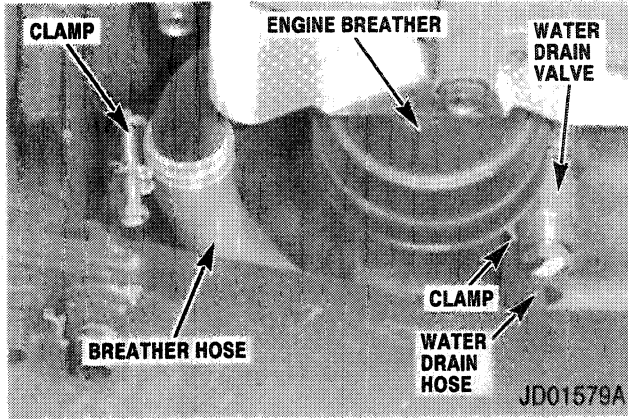

Loosen the clamp securing the breather hose and disconnect the breather hose. Using pliers, remove the clamp from the water drain hose connected to the water drain valve. Disconnect the water drain hose. Pull the hoses from the clips installed on the engine.

**STEP 12**

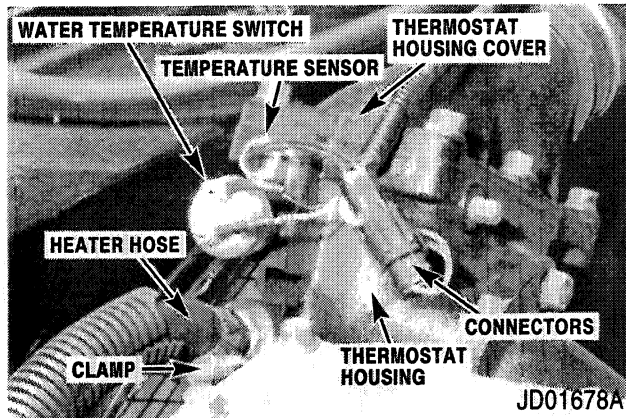

Disconnect the temperature sensor connector from the wiring harness connector. Tag and disconnect the wiring harness two wires from the water temperature switch. Loosen the clamp and disconnect the heater hose from the fitting installed in the thermostat housing.

**STEP 13**

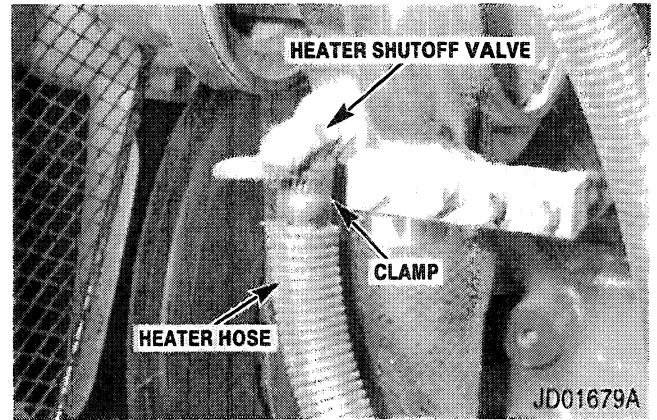

Loosen the clamp securing the heater hose to the heater shutoff valve. Disconnect the hose from the heater shutoff valve.

**STEP 14**

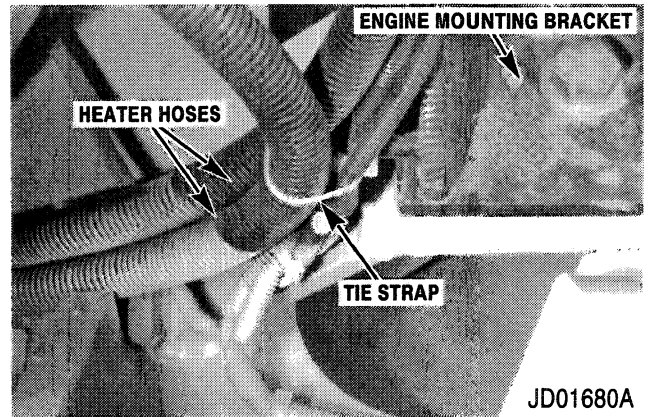

Cut, remove, and discard the tie strap holding the two heater hoses and the wiring harness to the engine mounting bracket.

**STEP 15**

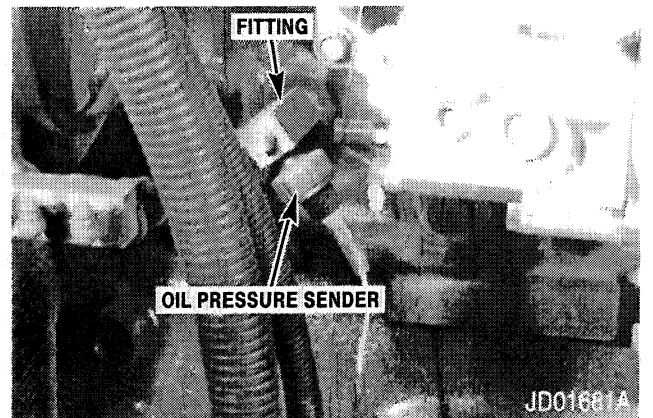

Tag and disconnect the wiring harness wire connected to the oil pressure sender.

**STEP 16**

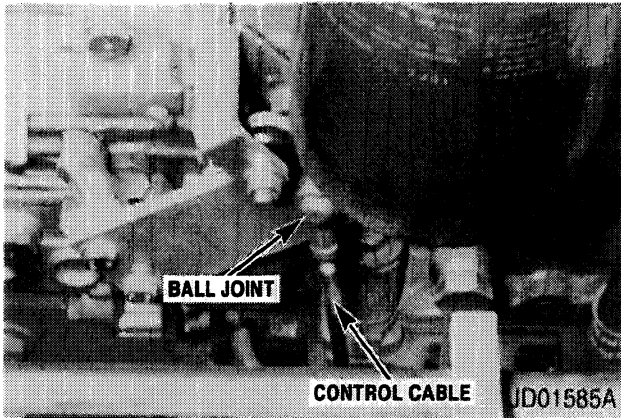

Remove the nut and lock washer securing the control cable ball joint to the fuel injection pump throttle bracket. Disconnect the ball joint.

**STEP 17**

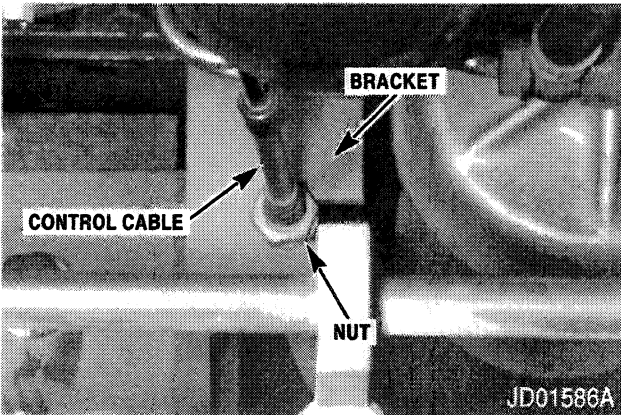

Loosen the two nuts securing the control cable to the bracket. Remove the control cable from the bracket.

**STEP 18**

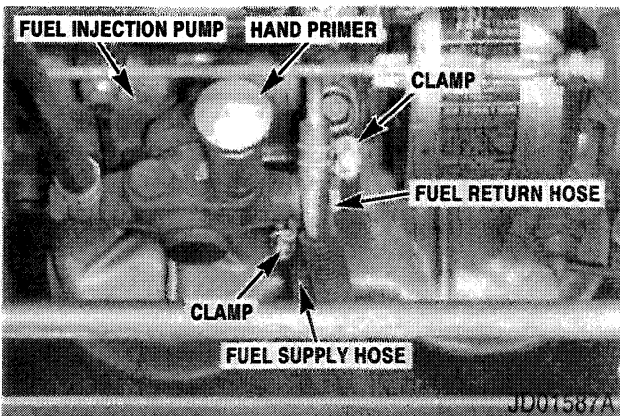

Tag the fuel supply hose and the fuel return hose. Loosen the two clamps and disconnect the hoses.

**STEP 19**

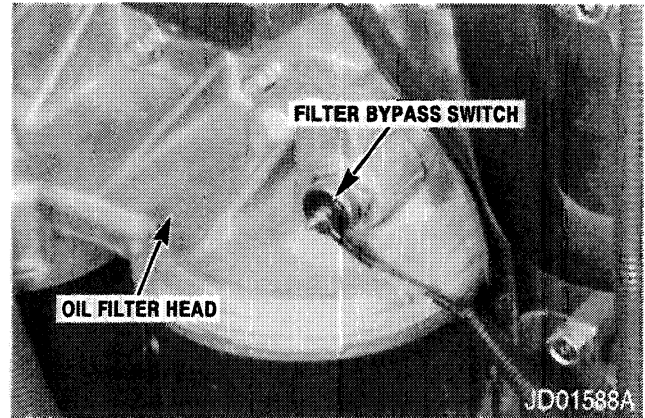

Tag and disconnect the wiring harness wire connected to the filter bypass switch.

**STEP 20**

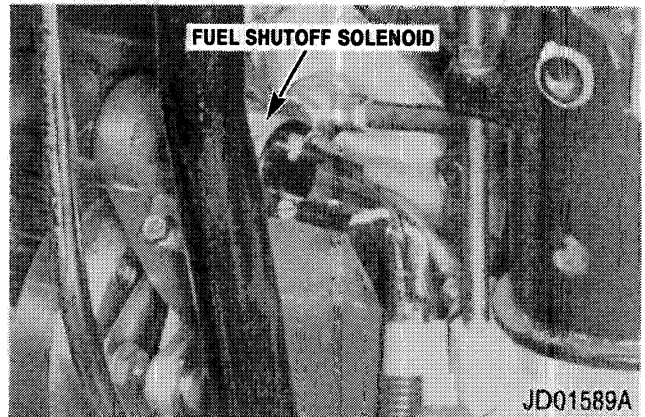

Tag and disconnect the wiring harness two wires connected to the fuel shutoff solenoid.

**STEP 21**

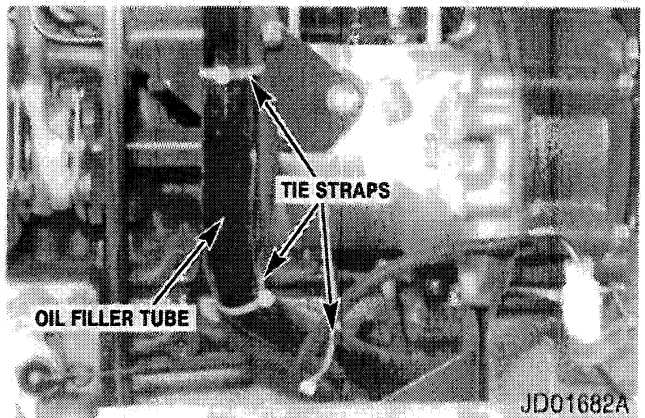

Cut, remove, and discard the three tie straps securing the wiring harness to the oil filler tube.

**STEP 22**

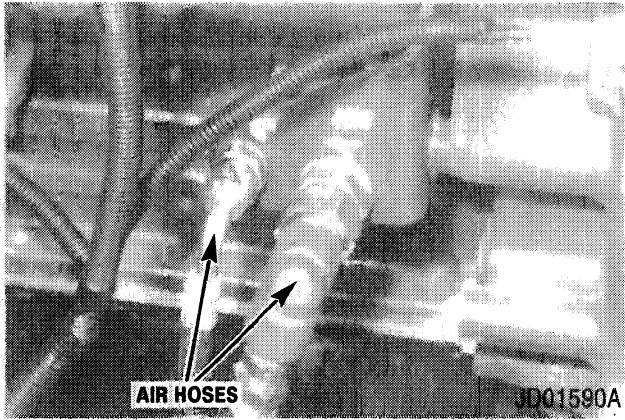

Tag and disconnect the two air hoses.

**STEP 23**

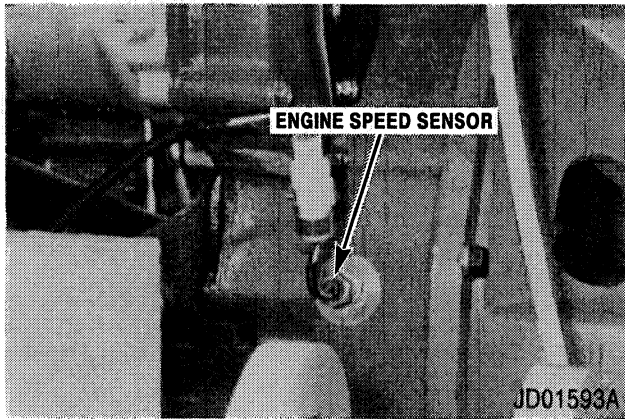

Disconnect the wiring harness connector from the engine speed sensor.

**STEP 24**

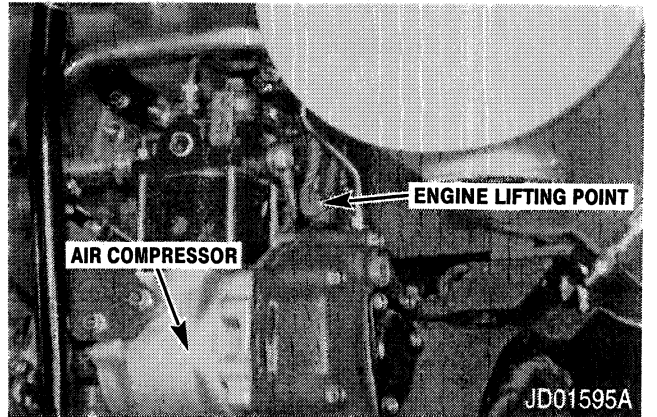
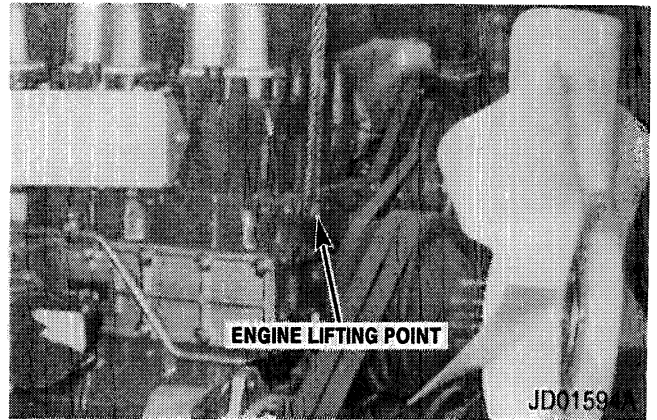

Connect suitable lifting equipment to the engine at the two lifting points. The weight of the engine is 2249 pounds (1020 kg).

### STEP 25

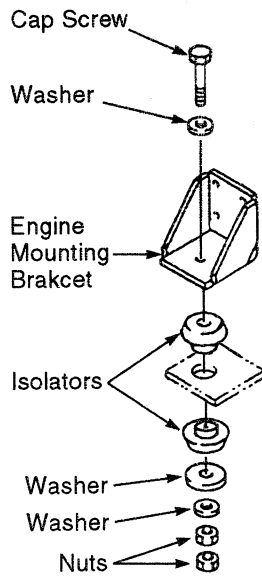
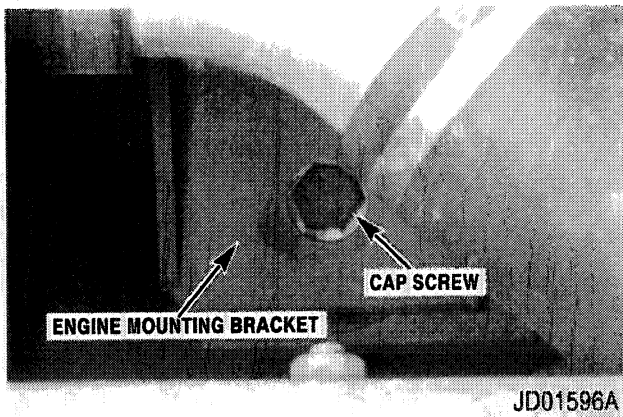

JS01597A

Remove the two nuts, three washers, rubber isolator, and cap screw. Repeat this step for the remaining three engine mounts.

### STEP 26

**NOTE:** When raising the engine from the machine check and make sure all wires and hoses have been disconnected and will not interfere with the removal of the engine.

Raise the engine from the mounts. Move the engine rearward and away from the machine.

### STEP 27

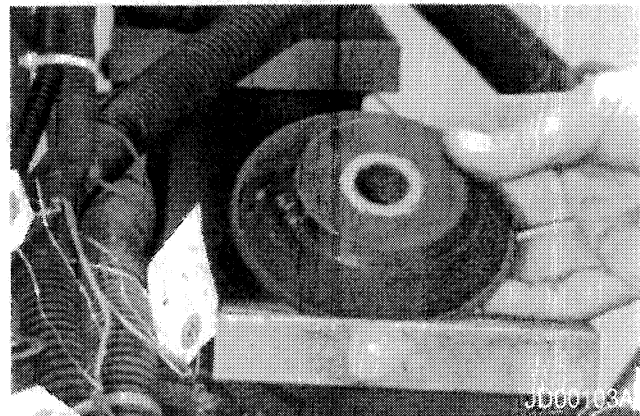
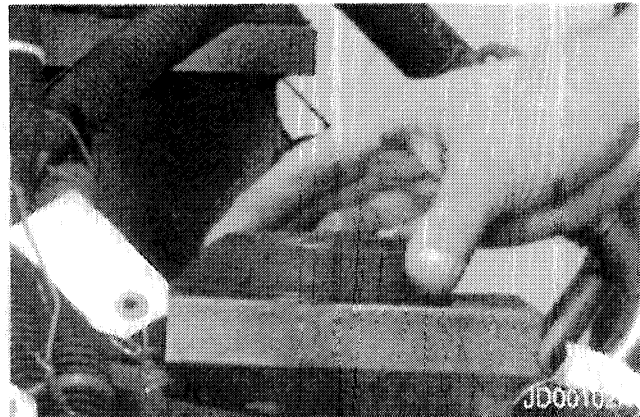

Remove the rubber engine isolators from the four engine mounts.

# Installation

## STEP 1

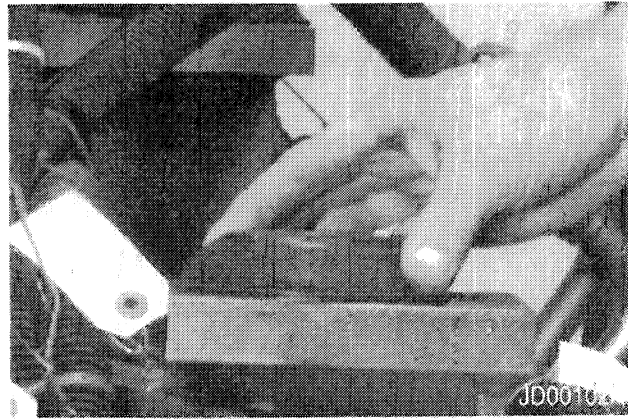
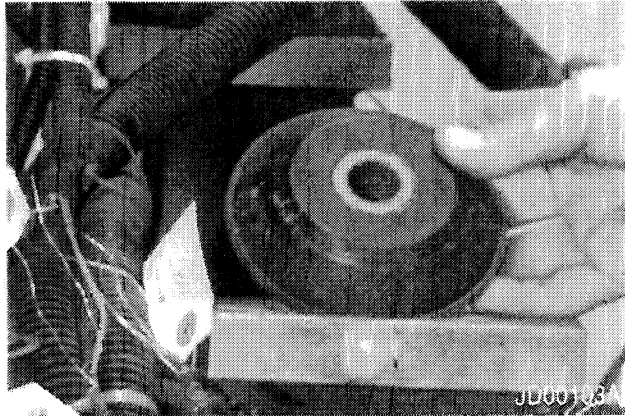

Inspect the rubber engine isolators for cracks, deterioration, or damage. Replace the isolators if cracked, deteriorated, or damaged. Install the rubber engine isolators on the four engine mounts.

## STEP 2

Connect suitable lifting equipment to the engine. The weight of the engine is 2249 pounds (1020 kg). Move the engine into position and lower onto the engine mounts.

## STEP 3

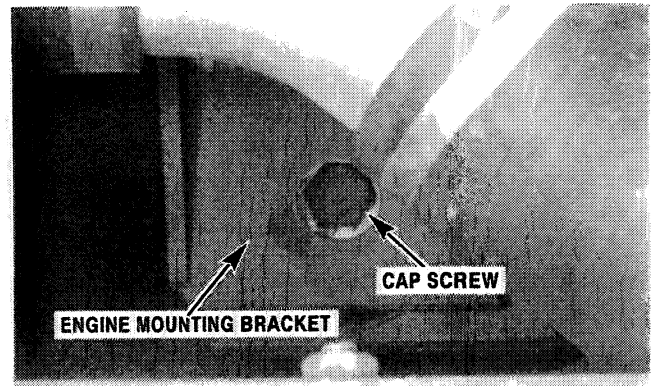

JD01596A

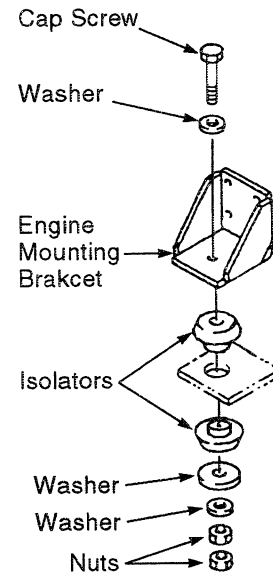

JS01597A

Apply Loctite 262 to the threads of the cap screw. Install the rubber isolator, cap screw, three washers, and one nut. Tighten the cap screw to 215 to 245 lb-ft (290 to 335 Nm). Install the second nut and tighten securely against the first nut. Repeat this step for the remaining three engine mounts.

## STEP 4

Disconnect the lifting equipment from the engine lifting points.

### STEP 5

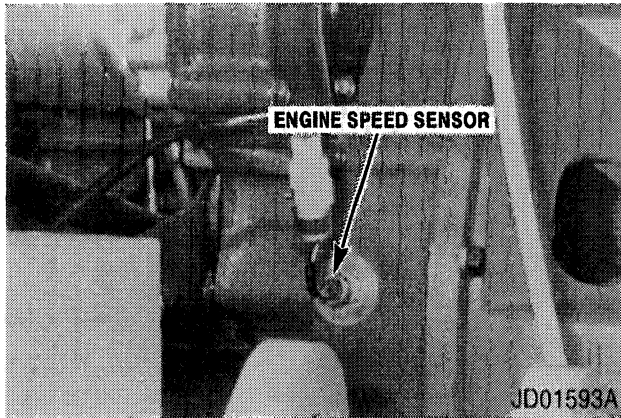

Connect the wiring harness connector to the engine speed sensor.

### STEP 8

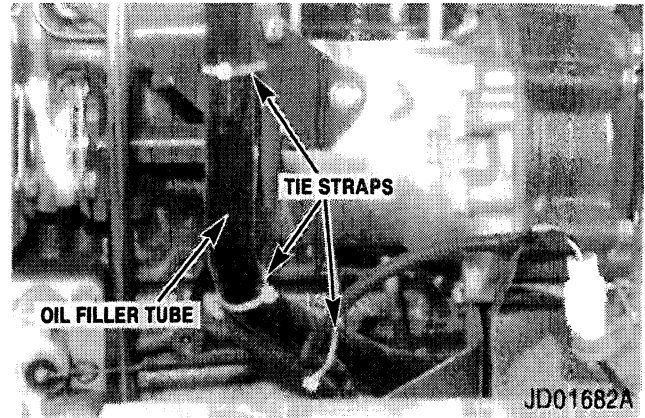

Install three new tie straps to secure the wiring harness to the oil filler tube.

### STEP 6

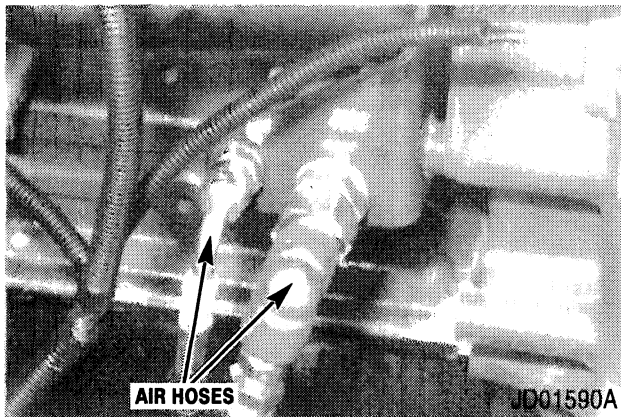

Connect the two air hoses following the tags installed during removal. Remove and discard the tags.

### STEP 9

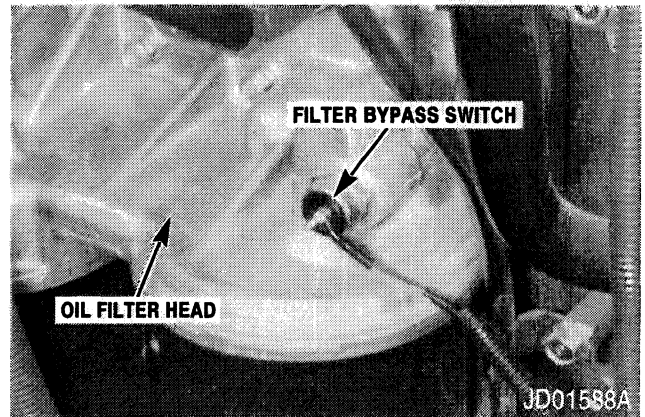

Connect the wiring harness wire to the filter bypass switch following the tag installed during removal. Remove and discard the tag.

### STEP 7

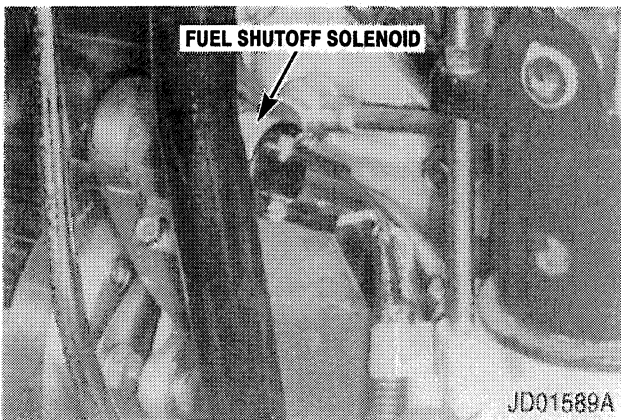

Connect the wiring harness two wires to the fuel shutoff solenoid following the tags installed during removal. Remove and discard the tags.

**STEP 10**

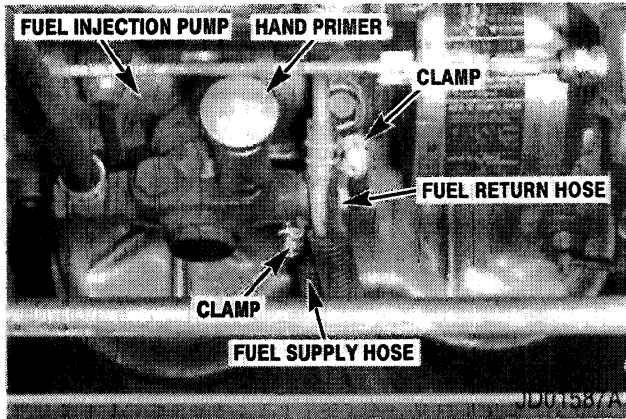

Install a clamp on the fuel return hose and the fuel supply hose. Connect the fuel return hose and the fuel supply hose to the fittings following the tags installed during removal. Position the clamps on the hoses and tighten the clamps to secure the hoses. Remove and discard the tags.

**STEP 11**

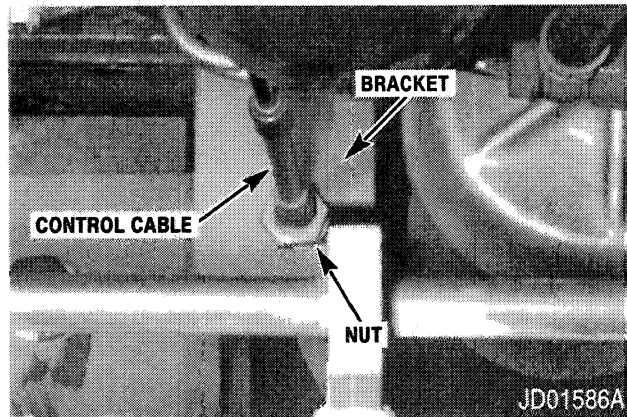

Install the control cable on the bracket and tighten the two nuts to secure the control cable.

**STEP 12**

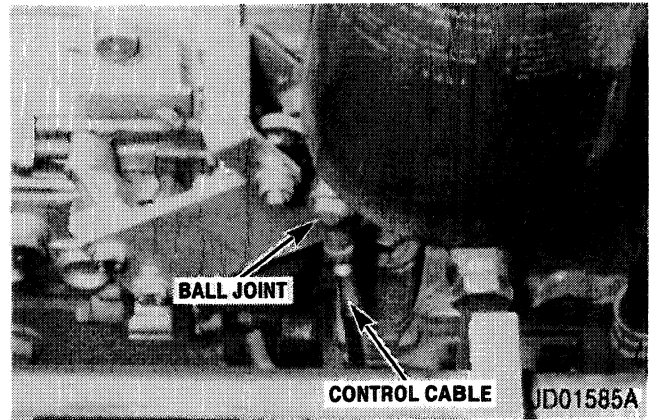

Connect the control cable ball joint to the fuel injection pump throttle bracket. Install the lock washer and nut to secure the ball joint.

**STEP 13**

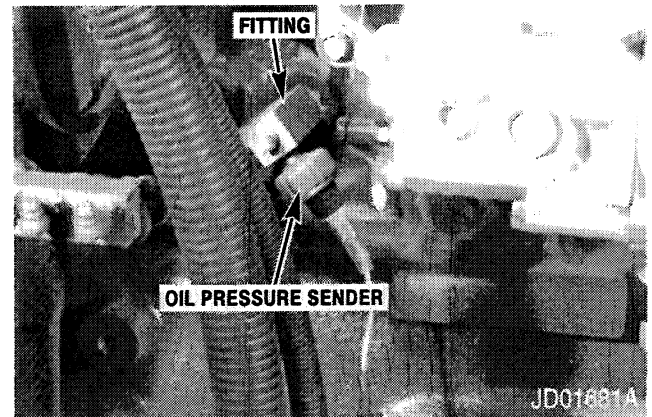

Connect the wiring harness wire to the oil pressure sender following the tag installed during removal. Remove and discard the tag.

**STEP 14**

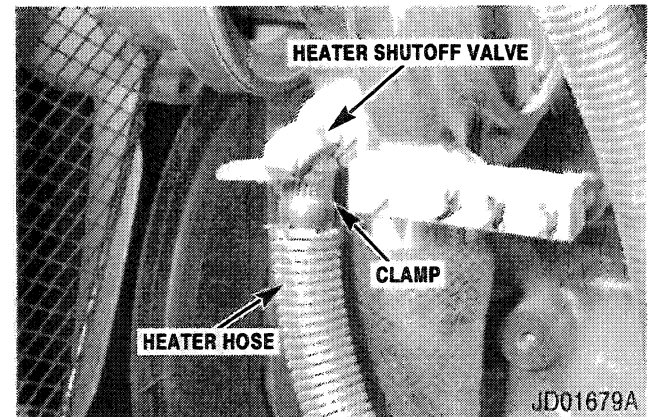

Install the clamp on the heater hose. Connect the hose to the heater shutoff valve and tighten the clamp to secure the hose.

**STEP 15**

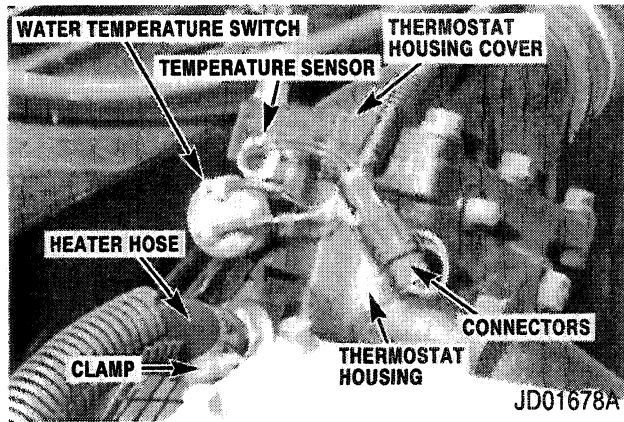

Install the clamp on the heater hose. Connect the heater hose to the fitting installed in the thermostat housing. Tighten the clamp to secure the heater hose. Connect the wiring harness two wires to the water temperature switch following the tags installed during removal. Connect the temperature sensor connector to the wiring harness connector.

**STEP 16**

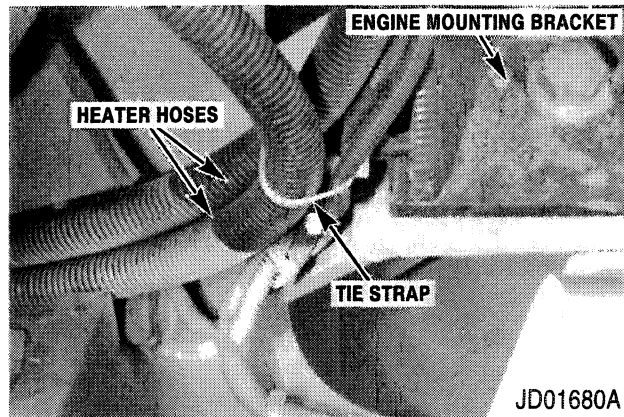

Install a new tie strap to secure two heater hoses and the wiring harness to the engine mounting bracket.

**STEP 17**

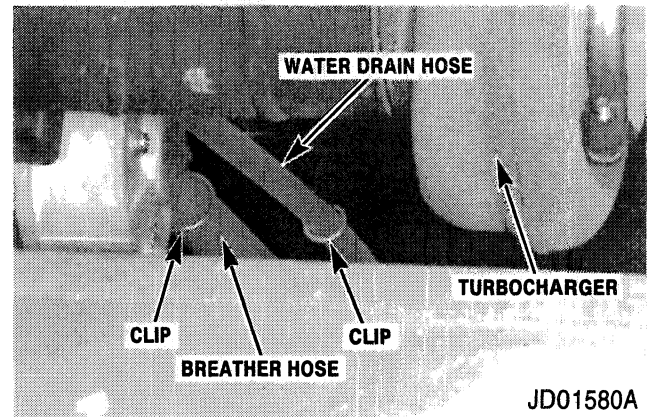
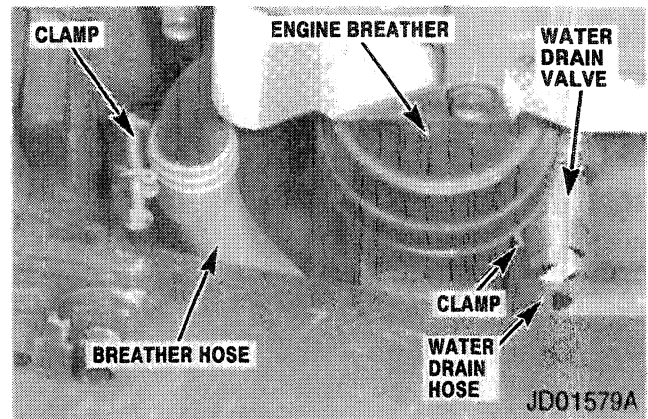

Route the water drain hose and the breather hose through the clips installed in the engine. Using pliers, install the clamp on the water drain hose and connect the water drain hose to the water drain valve. Install the clamp on the breather hose. Connect the breather hose and tighten the clamp.

**STEP 18**

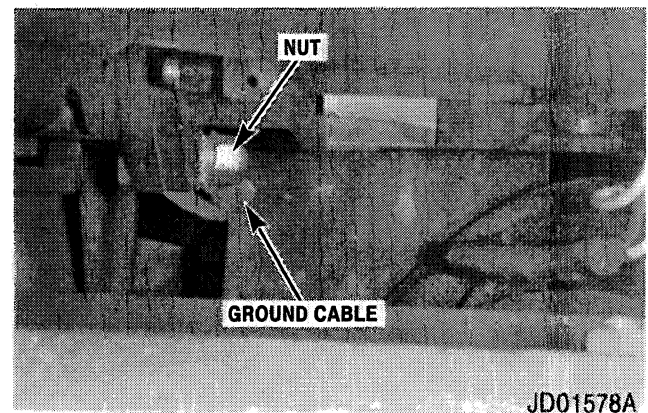

Connect the ground cable to the engine flywheel housing and install the lock washer and nut.

**STEP 19**

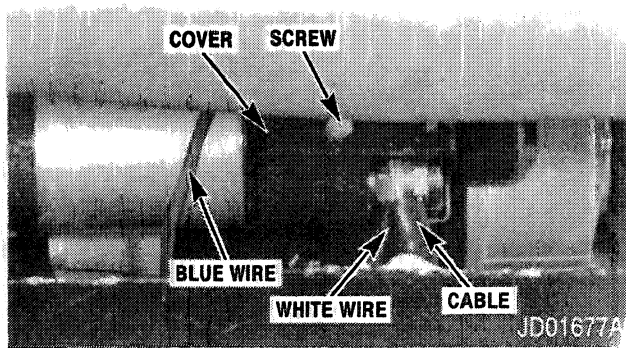

Connect the wiring harness white wire and the cable to the large terminal of the starter assembly following the tags installed during removal. Connect the wiring harness blue wire to the starter assembly following the tag installed during removal. Install the cover on the starter assembly and secure using the flat washer, lock washer, and screw. Remove the tags from the wiring harness wires and cable and discard the tags.

**STEP 20**

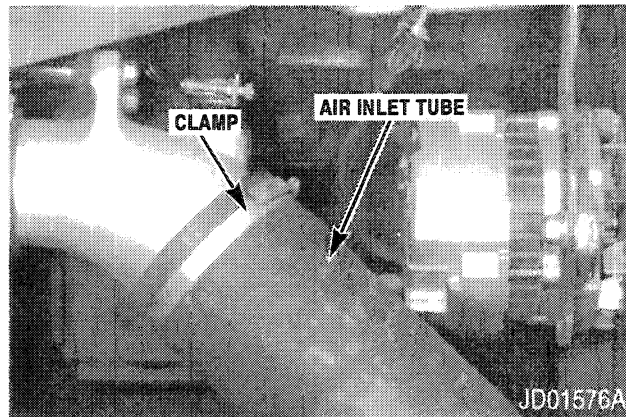

Connect the air inlet tube to the turbocharger. Tighten the clamp to secure the tube.

**STEP 21**

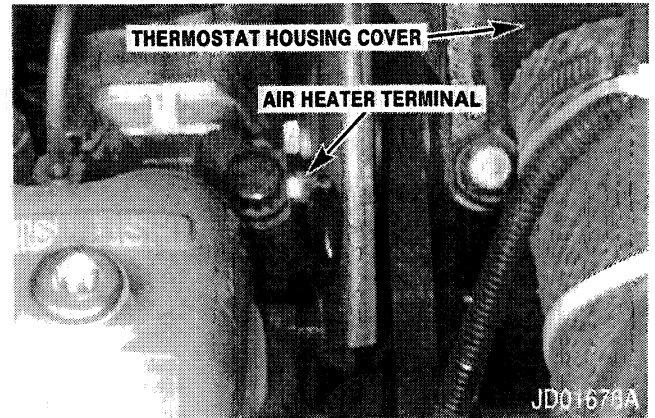

Connect the wiring harness wire to the air heater terminal following the tag installed during removal. Remove and discard the tag.

**STEP 22**

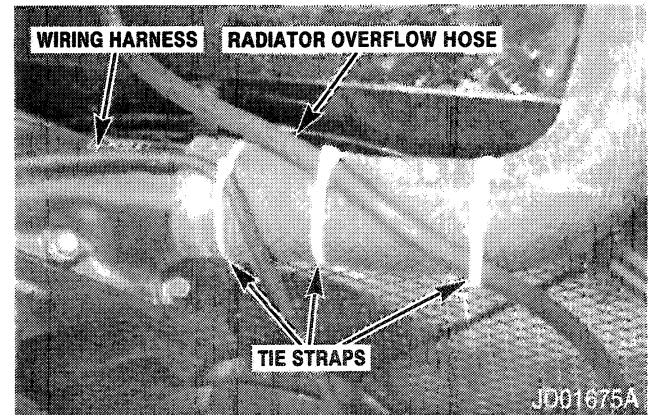

Install three new tie straps to secure the wiring harness and the radiator overflow hose to the radiator hose.

**STEP 23**

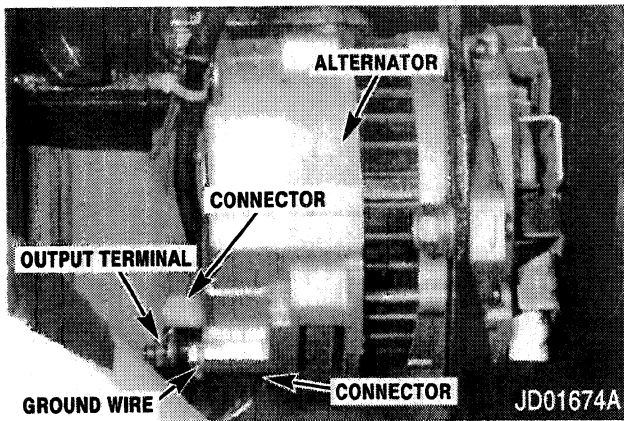

Connect the wiring harness wire to the alternator output terminal following the tag installed during removal. Connect the wiring harness ground wire and the two connectors to the alternator following the tags installed during removal. Remove and discard the tags.

**STEP 24**

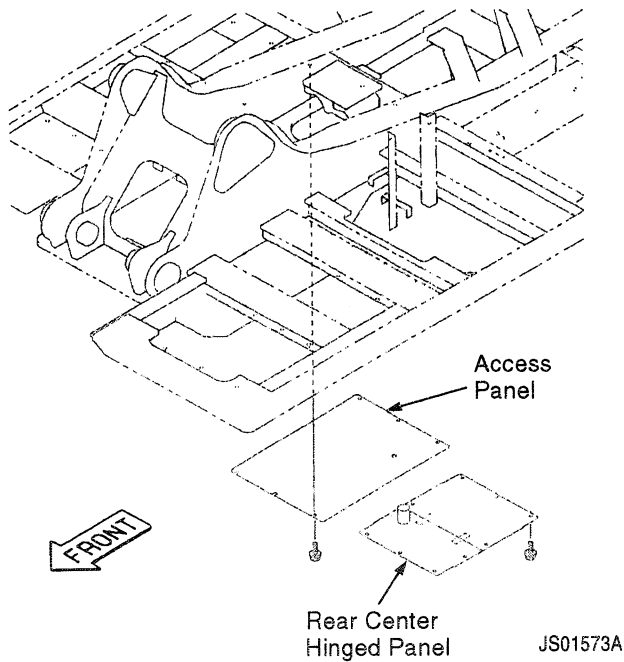

Swing the rear center hinged panel below the engine up. Secure the hinged panel using five cap screws. Install the bottom right rear access panel.

**STEP 25**

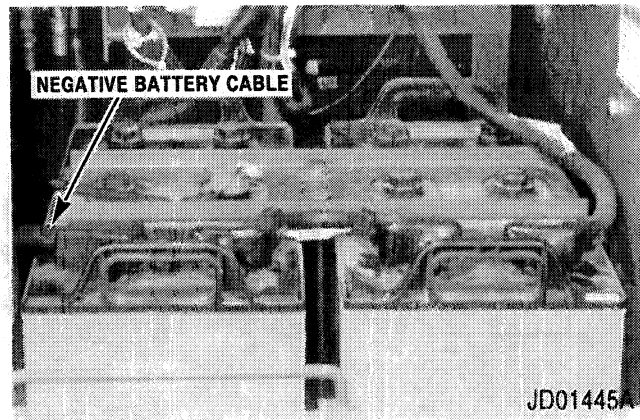

Connect the negative battery cable to the battery.

**STEP 26**

Install the radiator, oil cooler, and the cooling system reservoir. Service the radiator coolant. (See Section 2001.)

**STEP 27**

Install the hydraulic pump. (See Section 8002.)

# ENGINE

## Removal

**NOTE:** Make sure engine is cool before starting removal procedures.

### STEP 1

Remove the hydraulic pump (see Section 8002).

### STEP 2

Remove the radiator and the cooling system reservoir (see Section 2001).

### STEP 3

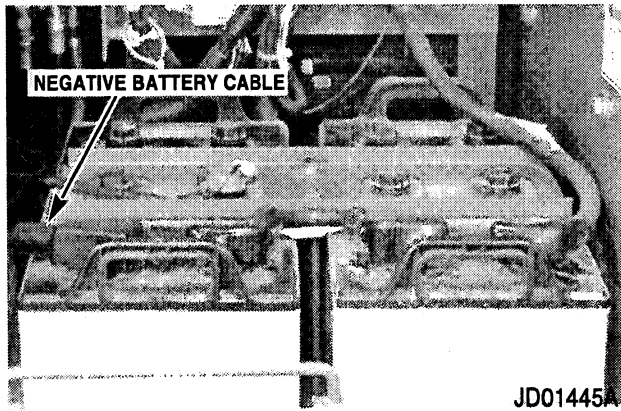

JD01445A

Open the left side access doors. Disconnect the negative battery cable from the battery.

### STEP 4

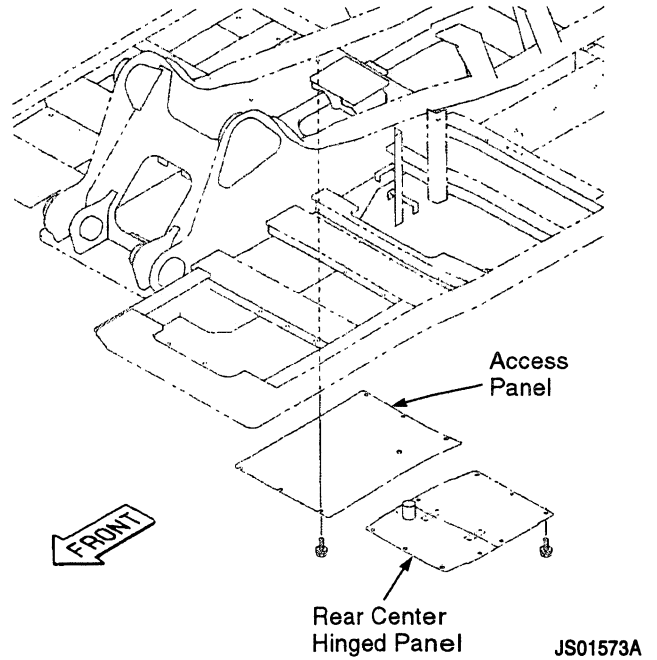

Remove the bottom right rear access panel. Remove the five cap screws securing the rear center hinged panel below the engine. Swing the panel down for access to the engine two left mounts.

### STEP 5

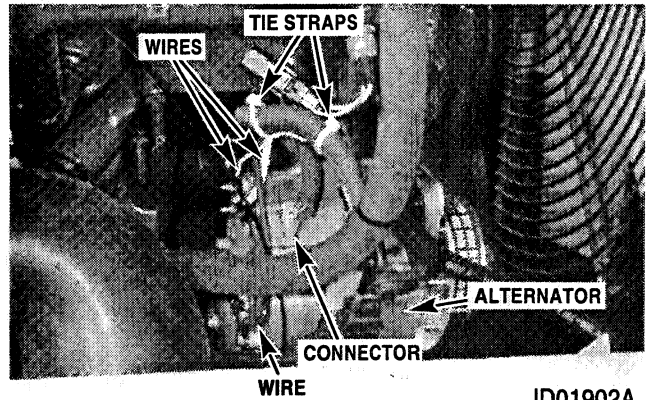

Tag and disconnect the wiring harness three wires and the connector from the alternator. Cut, remove and discard the two tie straps.

### STEP 6

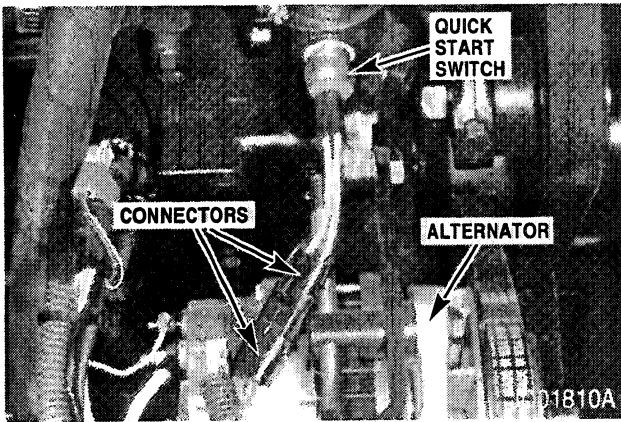

Tag and disconnect the wiring harness connector from the quick start switch connector.

### STEP 7

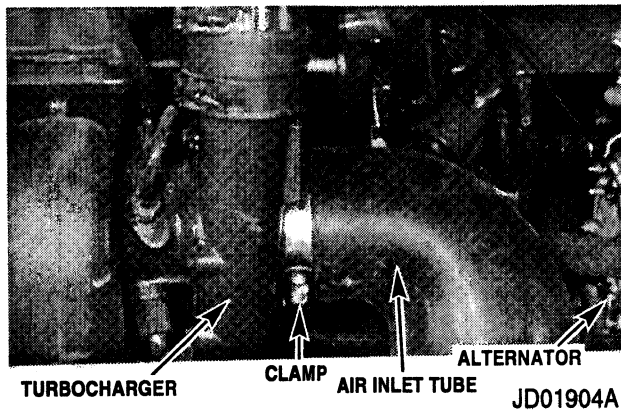

Loosen the two clamps securing the air inlet tube to the turbocharger and the outlet tube of the air cleaner. Disconnect and remove the air inlet tube.

### STEP 8

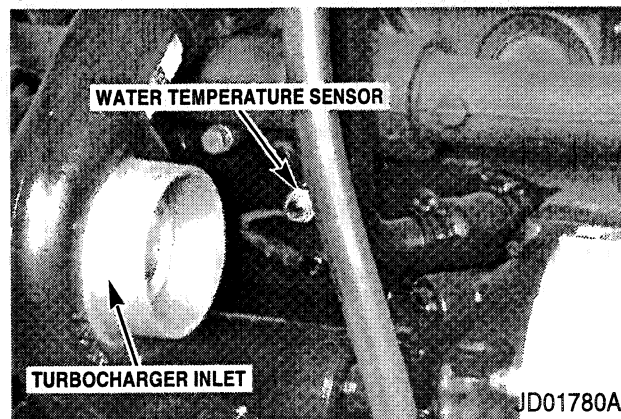

Tag and disconnect the wiring harness connector from the water temperature sensor connector.

### STEP 9

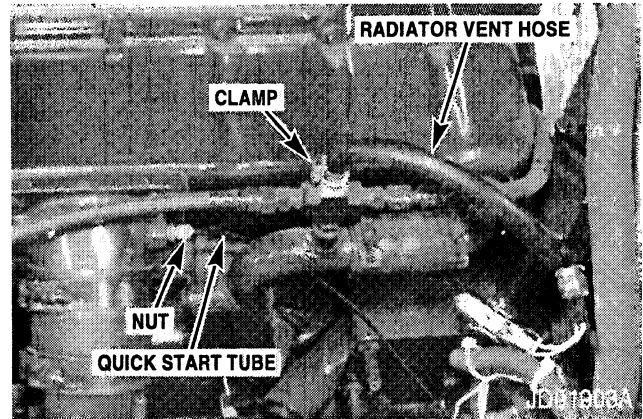

Loosen the nut securing the quick start tube to the fitting in the intake manifold. Disconnect the tube from the fitting. If necessary, loosen the clamp and remove the radiator vent hose from the machine.

### STEP 10

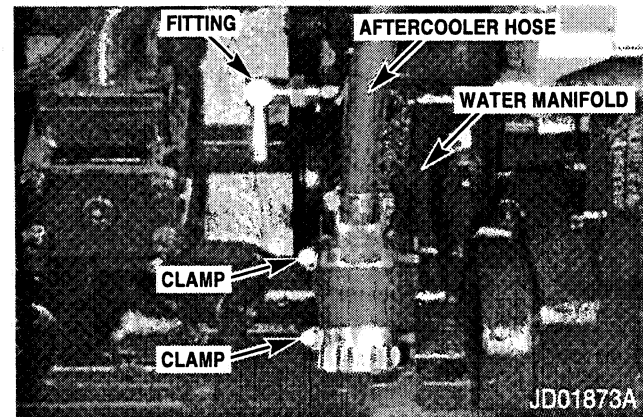

Loosen the clamp and disconnect the radiator bottom hose from the engine water manifold. Remove the hose. If necessary, loosen the clamp and disconnect and remove the aftercooler hose. Loosen the clamp on the heater hose. Disconnect the heater hose from the fitting installed in the engine water manifold.

### STEP 11

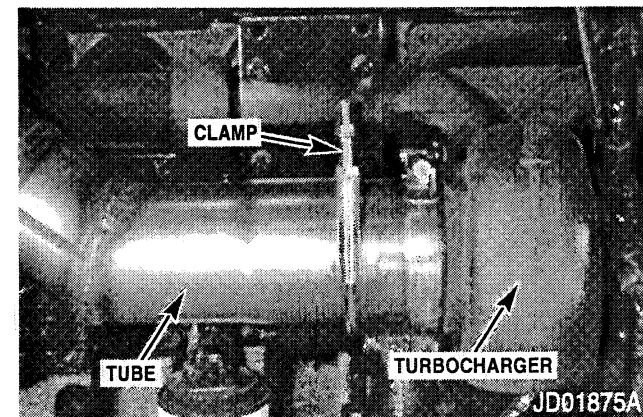

Loosen the clamp securing the tube to the turbocharger. Remove the tube.

**STEP 12**

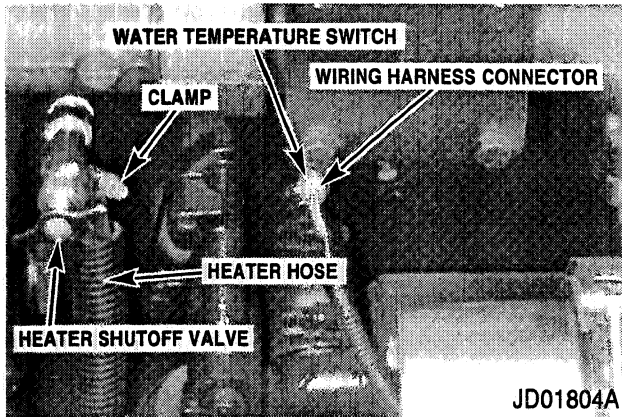

Install identification tags on the heater hose and the wiring harness connector. Loosen the clamp and disconnect the heater hose from the heater shutoff valve. Disconnect the wiring harness connector from the water temperature switch.

**STEP 13**

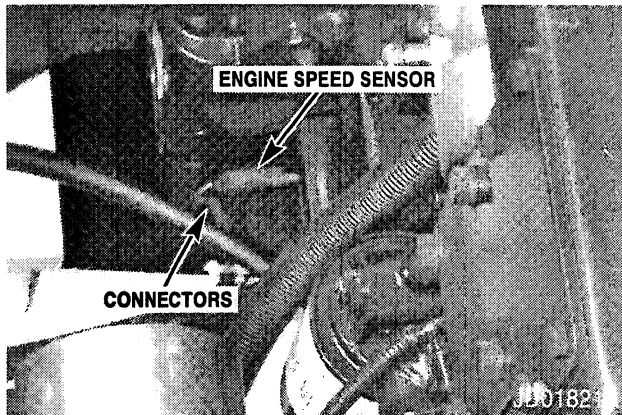

Tag and disconnect the engine speed sensor connector from the wiring harness connector.

**STEP 14**

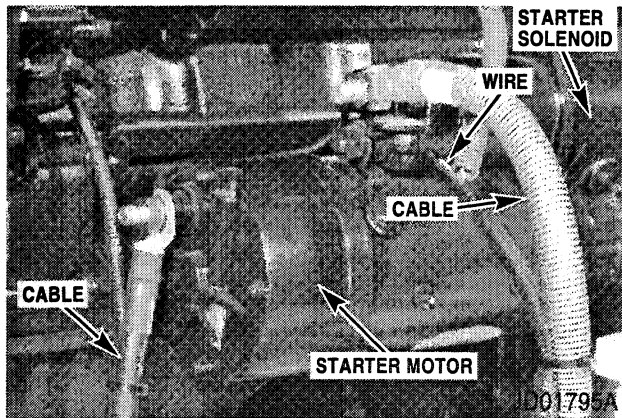

Tag and disconnect the cable and the wiring harness wire from the starter solenoid. Tag and disconnect the cable from the rear terminal of the starter motor.

**STEP 15**

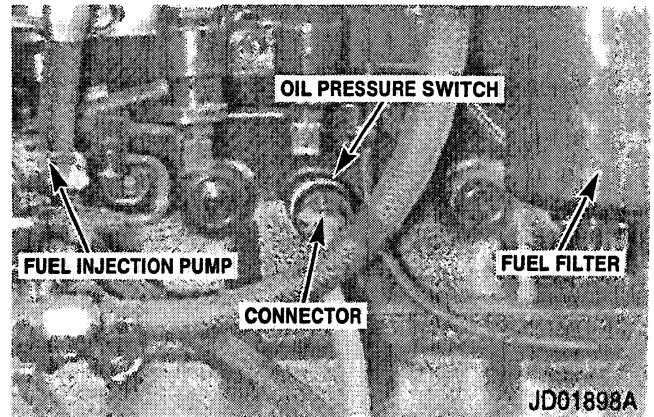

Tag and disconnect the wiring harness connector from the oil pressure switch.

**STEP 16**

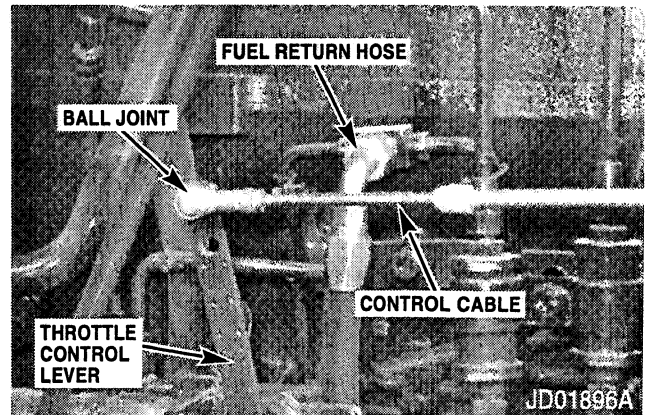

Remove the nut and lock washer securing the control cable ball joint to the fuel injection pump throttle control lever. Disconnect the ball joint. Tag and disconnect the fuel return hose from the engine fuel return line.

**STEP 17**

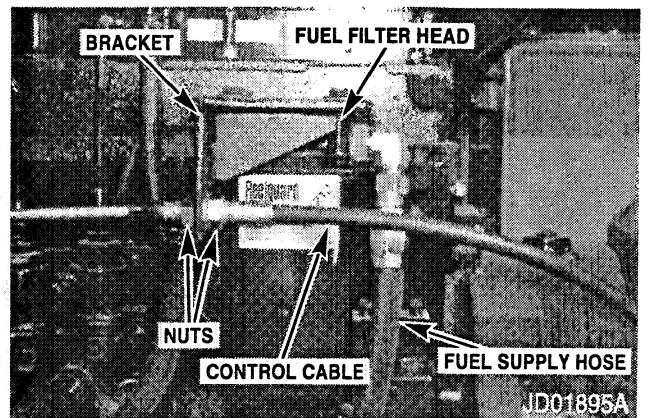

Loosen the two nuts securing the control cable to the bracket. Remove the control cable from the bracket. Tag and disconnect the fuel supply hose from the fuel filter head.

**STEP 18**

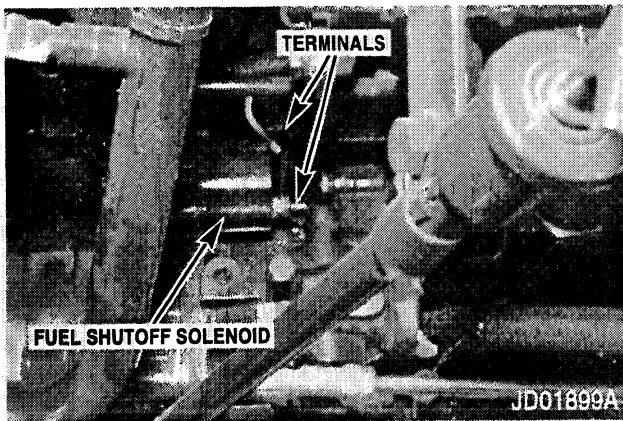

Tag and disconnect the wiring harness two wires connected to the fuel shutoff solenoid terminals.

**STEP 19**

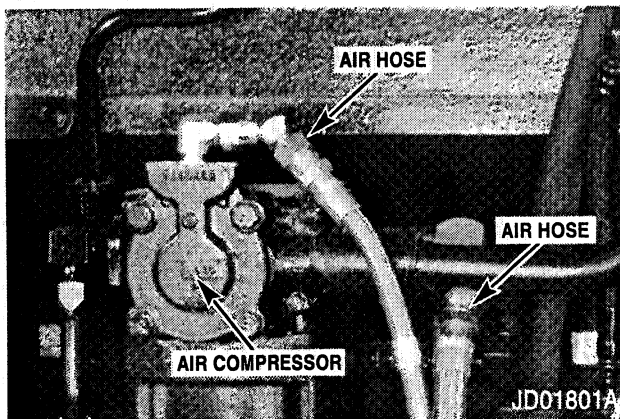

Tag and disconnect the two air hoses from the air compressor.

**STEP 20**

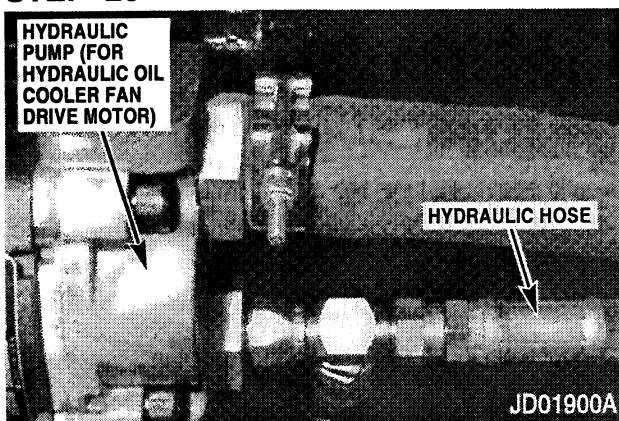

Tag and identify the hydraulic hose connected to the hydraulic pump for the hydraulic oil cooler fan drive motor. Disconnect the hydraulic hose from the hydraulic pump. Plug the hose and cap the fitting to prevent entry of contaminants into the hydraulic system.

**STEP 21**

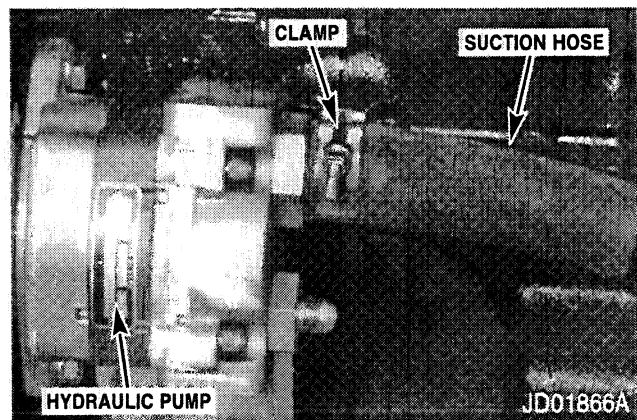

Loosen the clamp and disconnect the suction hose from the hydraulic pump. Remove the suction hose from the machine. Plug the hose and cap the fitting to prevent entry of contaminants into the hydraulic system.

**STEP 22**

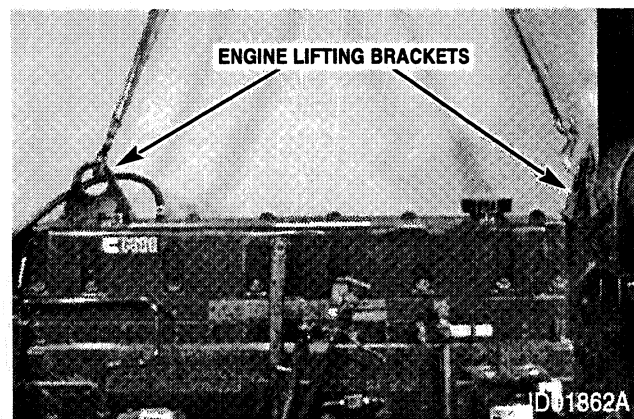

Connect suitable lifting equipment to the engine at the two engine lifting brackets. The weight of the engine is 2249 pounds (1020 kg).

### STEP 23

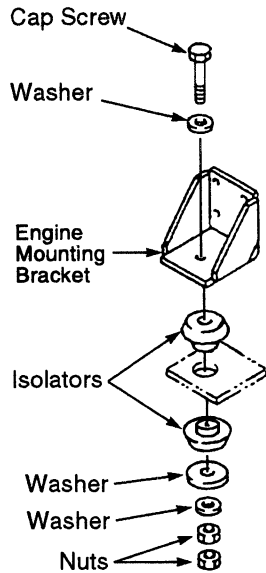
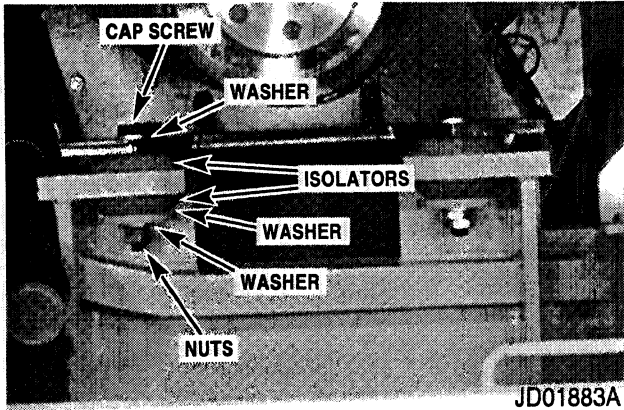

Remove the two nuts, three washers, rubber isolator, and cap screw. Repeat this step for the remaining three engine mounts.

### STEP 24

**NOTE:** When raising the engine from the machine check and make sure all wires and hoses have been disconnected and will not interfere with the removal of the engine.

Raise the engine from the mounts. Move the engine rearward and away from the machine.

### STEP 25

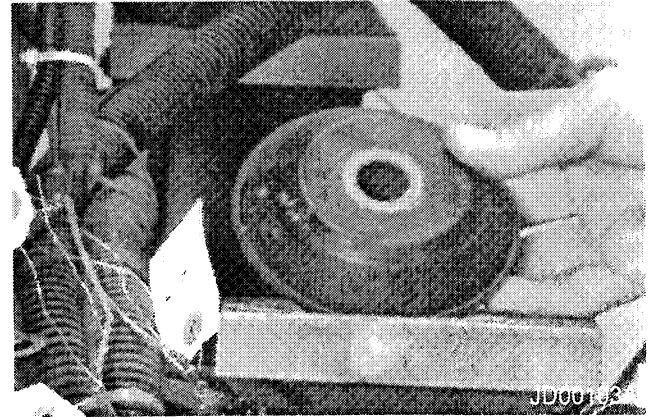
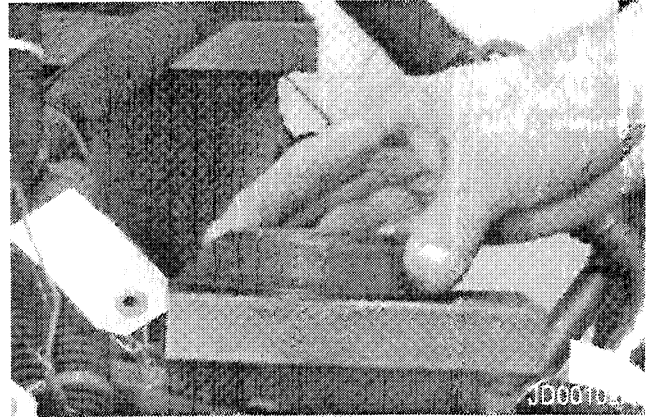

Remove the rubber engine isolators from the four engine mounts.



**Suggest:**

**If the above button click is invalid.**

**Please download this document**

**first, and then click the above link**

**to download the complete manual.**

**Thank you so much for reading**

## Installation

### STEP 1

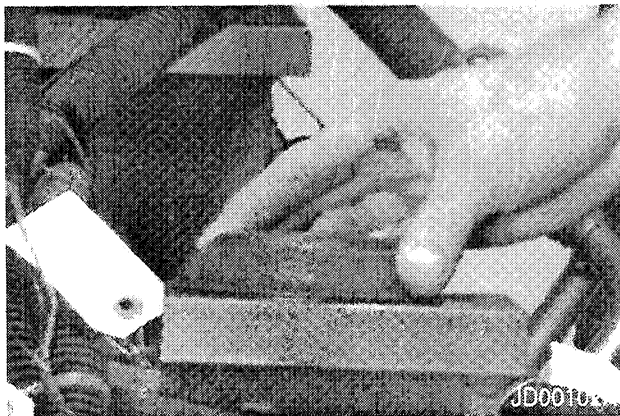
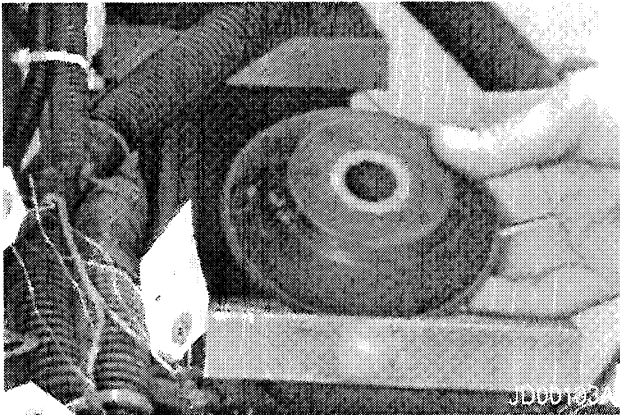

Inspect the rubber engine isolators for cracks, deformation, or damage. Replace the isolators if cracked, deteriorated, or damaged. Install the rubber engine isolators on the four engine mounts.

### STEP 2

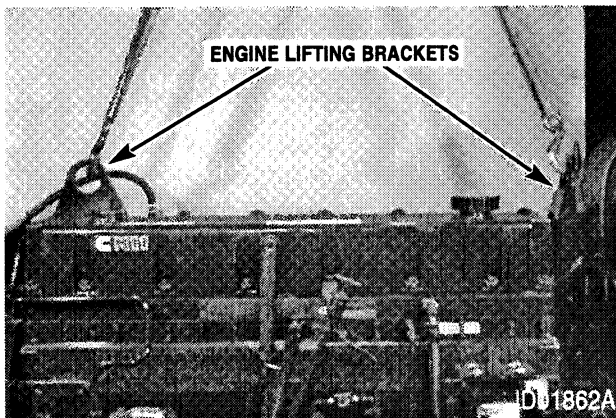

Connect suitable lifting equipment to the engine at the two engine lifting brackets. The weight of the engine is 2249 pounds (1020 kg). Move the engine into position and lower onto the engine mounts.

### STEP 3

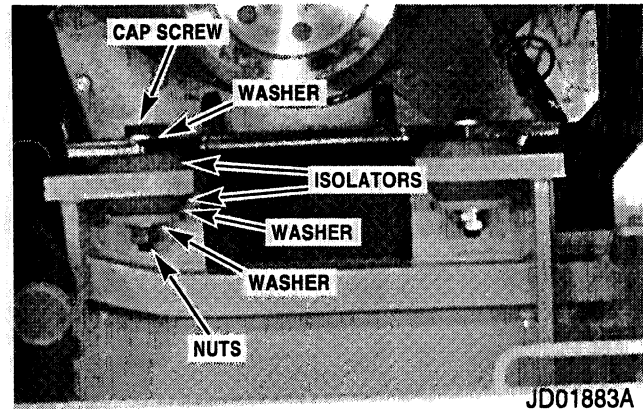

JD01883A

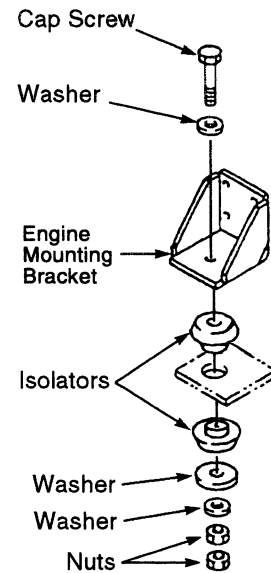

JS01597A

Apply Loctite 262 to the threads of the cap screws. Install the rubber isolator, cap screw, three washers, and one nut. Tighten the cap screw to 215 to 245 lb-ft (290 to 335 Nm). Install the second nut and tighten securely against the first nut. Repeat this step for the remaining three engine mounts.

### STEP 4

Disconnect the lifting equipment from the engine lifting brackets.

**<https://www.ebooklibonline.com>**

Hello dear friend!

Thank you very much for reading.

Enter the link into your browser.

The full manual is available for immediate download.

**<https://www.ebooklibonline.com>**