

9060 Excavator Service Manual

Table of Contents

Description	Section No.	Form No.
General Tab 1		
Section Index - General		7-47050
Standard Torque Specifications for 9000 Series Excavators	1001	7-44790
Fluids and Lubricants	1002	7-47000
Engines Tab 2		
Section Index - Engines		7-47060
Engine Specification Details	2000	7-47010
Engine Removal and Installation	2001	7-47070
Radiator Removal and Installation	2002	7-47080
Mitsubishi Motors Shop Manual		
Fuel System Tab 3		
Section Index - Fuel System		7-47490
See Mitsubishi Motors Shop Manual in Tab 2		
Electrical Tab 4		
Section Index - Electrical		7-47090
Electrical Specifications and Troubleshooting	4001	7-46820
Electrical Schematic Foldout	In Rear Pocket	7-46810
Batteries	4002	7-44950
Systems Display Panel	4005	7-44980
Starter and Starter Solenoid	See Mitsubishi Motors Shop Manual in Tab 2	
Alternator	See Mitsubishi Motors Shop Manual in Tab 2	
Tracks Tab 5		
Section Index - Tracks		7-47100
Troubleshooting the Track System	5001	7-44830
Tracks, Rollers, and Idlers	5002	7-47110
Power Train Tab 6		
Section Index - Power Train		7-47120
Troubleshooting - See Section 8001		
Drive Motor and Final Drive Transmission	6000	7-47130
Hydraulics Tab 8		
Section Index - Hydraulics		7-47140
Cleaning the Hydraulic System	8000	7-45050
Hydraulic Specifications, Troubleshooting, and Pressure Checks	8001	7-47020
Hydraulic Schematic Foldout	In Rear Pocket	7-46810
Main Hydraulic Pump	8002	7-47150

9060 Excavator Service Manual

Table of Contents

Description	Section No.	Form No.
Pilot Control Circuit Pump	8003	7-47160
Hydraulic Swivel	8004	7-47170
Main Control Valve	8005	7-47180
Remote Control Valves	8006	7-47190
Solenoid Valves	8007	7-47200
Swing Motor and Swing Reduction Gear Box	8008	7-47210
Cylinders	8009	7-47220
Cushion Control Valve	8010	7-47230
Mounted Equipment		Tab 9
Section Index - Mounted Equipment		7-47240
Pedals and Levers	9001	7-47030
Turntable Bearing	9003	7-47250
Boom and Arm	9004	7-47260
Seat	9006	7-45170
Electrical Schematic Foldout	In Rear Pocket	7-46810
Hydraulic Schematic Foldout	In Rear Pocket	7-46810

Section 1001

STANDARD TORQUE SPECIFICATIONS FOR 9000 SERIES EXCAVATORS



Bur 7-44790

Copyright © 1992 CASE CORPORATION
Printed in U.S.A.
Issued November 1992

<https://www.ebooklibonline.com>

Hello dear friend!

Thank you very much for reading.

Enter the link into your browser.

The full manual is available for immediate download.

<https://www.ebooklibonline.com>

TABLE OF CONTENTS

TORQUE SPECIFICATIONS - DECIMAL HARDWARE2

TORQUE SPECIFICATIONS - METRIC HARDWARE3

TORQUE SPECIFICATIONS - STEEL HYDRAULIC FITTINGS4

TORQUE SPECIFICATIONS - O-RING FACE SEAL FITTINGS5

TORQUE SPECIFICATIONS - DECIMAL HARDWARE

Use the torques in this chart when special torques are not given. These torques apply to fasteners with both UNC and UNF threads as received from suppliers, dry, or when lubricated with engine oil. Not applicable if special graphites, molydisulfide greases, or other extreme pressure lubricants are used.

Grade 5 Bolts, Nuts, and Studs		
		
Size	Pound-Feet	Newton metres
1/4 in	9-11	12-15
5/16 in	17-21	23-28
3/8 in	35-42	48-57
7/16 in	54-64	73-87
1/2 in	80-96	109-130
9/16 in	110-132	149-179
5/8 in	150-180	203-244
3/4 in	270-324	366-439
7/8 in	400-480	542-651
1.0 in	580-696	787-944
1-1/8 in	800-880	1085-1193
1-1/4 in	1120-1240	1519-1681
1-3/8 in	1460-1680	1980-2278
1-1/2 in	1940-2200	2631-2983

Grade 8 Bolts, Nuts, and Studs		
		
Size	Pound-Feet	Newton metres
1/4 in	12-15	16-20
5/16 in	24-29	33-39
3/8 in	45-54	61-73
7/16 in	70-84	95-114
1/2 in	110-132	149-179
9/16 in	160-192	217-260
5/8 in	220-264	298-358
3/4 in	380-456	515-618
7/8 in	600-720	814-976
1.0 in	900-1080	1220-1465
1-1/8 in	1280-1440	1736-1953
1-1/4 in	1820-2000	2468-2712
1-3/8 in	2380-2720	3227-3688
1-1/2 in	3160-3560	4285-4827

NOTE: Use thick nuts with Grade 8 bolts.

TORQUE SPECIFICATIONS - METRIC HARDWARE

Use the following torques when specifications are not given.

These values apply to fasteners with coarse threads as received from supplier, plated or unplated, or when lubricated with engine oil. These values do not apply if graphite or molydisulfide grease or oil is used.

Grade 8.8 Bolts, Nuts, and Studs		
		
Size	Pound-Feet	Newton metres
M6	6-7	8-9
M8	14-17	20-23
M10	29-34	39-46
M12	50-59	68-80
M16	128-149	173-202
M20	249-291	337-393
M22	342-399	464-541
M24	431-503	584-681
M27	637-743	864-1008
M30	863-1007	1170-1365
M33	1180-1377	1600-1867
M36	1977-2307	2680-3127
M42	2434-2840	3300-3850
M45	3054-3563	4140-4830
M48	3658-4268	4960-5787
M52	4757-5549	6450-7525
M56	5908-6893	8010-9345
M64	8925-10413	12100-14117

Grade 10.9 Bolts, Nuts, and Studs		
		
Size	Pound-Feet	Newton metres
M6	8-10	11-13
M8	20-24	28-32
M10	41-47	55-64
M12	71-83	96-112
M16	178-208	242-282
M20	350-408	475-554
M22	481-561	652-761
M24	606-707	821-958
M27	900-1050	1220-1423
M30	1217-1420	1650-1925
M33	1667-1945	2260-2637
M36	2124-2478	2880-3360
M39	2773-3235	3760-4387
M42	3422-3992	4640-5413
M45	4293-5009	5820-6790
M48	5141-5998	6970-8132
M52	6690-7805	9070-10582
M56	8334-9723	11300-13183
M64	12612-14714	17100-19950

Grade 12.9 Bolts, Nuts, and Studs



Usually the torque values specified for grade 10.9 fasteners can be used satisfactorily on grade 12.9 fasteners.

TORQUE SPECIFICATIONS - STEEL HYDRAULIC FITTINGS

Tube OD Hose ID	Thread Size	Pound- Feet	Newton metres
37 Degree Flare Fittings			
1/4 in 6.4 mm	7/16-20	6-12	8-16
5/16 in 7.9 mm	1/2-20	8-16	11-22
3/8 in 9.5 mm	9/16-18	10-25	14-34
1/2 in 12.7 mm	3/4-16	15-42	20-57
5/8 in 15.9 mm	7/8-14	25-58	34-79
3/4 in 19.0 mm	1-1/16-12	40-80	54-108
7/8 in 22.2 mm	1-3/16-12	60-100	81-135
1.0 in 25.4 mm	1-5/16-12	75-117	102-158
1-1/4 in 31.8 mm	1-5/8-12	125-165	169-223
1-1/2 in 38.1 mm	1-7/8-12	210-250	285-338

Tube OD Hose ID	Thread Size	Pound- Feet	Newton metres
Straight Threads with O-ring			
1/4 in 6.4 mm	7/16-20	12-19	16-26
5/16 in 7.9 mm	1/2-20	16-25	22-34
3/8 in 9.5 mm	9/16-18	25-40	34-54
1/2 in 12.7 mm	3/4-16	42-67	57-91
5/8 in 15.9 mm	7/8-14	58-92	79-124
3/4 in 19.0 mm	1-1/16-12	80-128	108-174
7/8 in 22.2 mm	1-3/16-12	100-160	136-216
1.0 in 25.4 mm	1-5/16-12	117-187	159-253
1-1/4 in 31.8 mm	1-5/8-12	165-264	224-357
1-1/2 in 38.1 mm	1-7/8-12	250-400	339-542

Split Flange Mounting Bolts*		
Size	Pound- Feet	Newton metres
5/16-18	15-20	20-27
3/8-16	20-25	27-34
7/16-14	35-45	47-61
1/2-13	55-65	74-88
5/8-11	140-150	190-203

**NOTE: Use standard metric hardware torque for metric split flange mounting bolts.*

TORQUE SPECIFICATIONS - O-RING FACE SEAL FITTINGS

Nom. SAE Dash Size	Tube OD	Thread Size	Pound- Feet	Newton metres	Thread Size	Pound- Feet	Newton metres
O-ring Face Seal End					O-ring Boss End Fitting or Lock Nut		
-4	1/4 in 6.4 mm	9/16-18	10-12	14-16	7/16-20	17-20	23-27
-6	3/8 in 9.5 mm	11/16-16	18-20	24-27	9/16-18	25-30	34-41
-8	1/2 in 12.7 mm	13/16-16	32-40	43-54	3/4-16	45-50	61-68
-10	5/8 in 15.9 mm	1-14	46-56	62-76	7/8-14	60-65	81-88
-12	3/4 in 19.0 mm	1-3/16-12	65-80	90-110	1-1/16-12	85-90	115-122
-14	7/8 in 22.2 mm	1-3/16-12	65-80	90-110	1-3/16-12	95-100	129-136
-16	1.0 in 25.4 mm	1-7/16-12	92-105	125-140	1-5/16-12	115-125	156-169
-20	1-1/4 in 31.8 mm	1-11/16-12	125-140	170-190	1-5/8-12	150-160	203-217
-24	1-1/2 in 38.1 mm	2-12	150-180	200-254	1-7/8-12	190-200	258-271

Section 2001

ENGINE REMOVAL AND INSTALLATION

ENGINE

Removal

1. Park the machine on a hard level surface. Lower the tool to the floor and stop the engine.

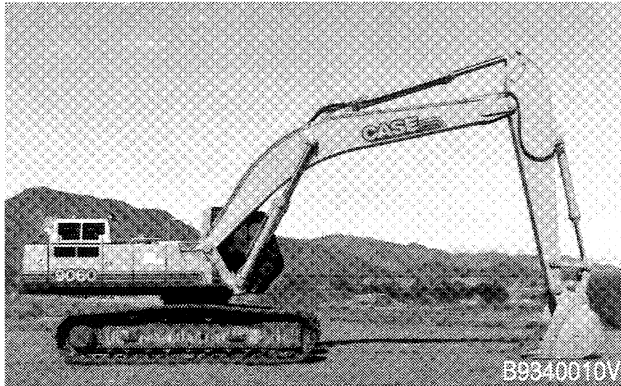

B9340010V

2. Remove the access door over the engine. Open the access doors on each side of the engine compartment. Remove the access covers from under the engine and the radiator.



B9340059

3. Open the drain valve for the air reservoir and release the air from the system. The drain valve is shown in the closed position.

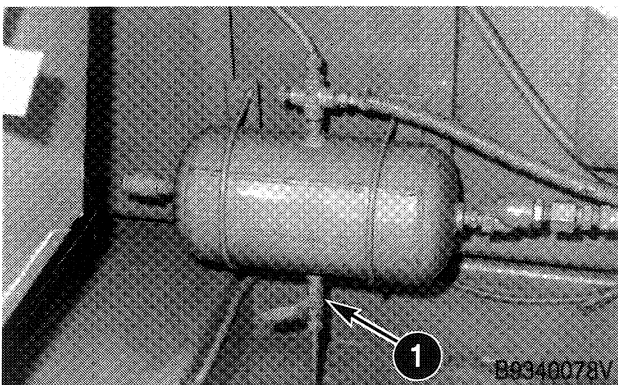

B9340078V

1. Drain Valve

4. Make sure that the engine is cool and remove the radiator cap. Open the drain valve and drain the cooling system. The cooling system holds 12.7 U.S. gallons (48 litres) of coolant.

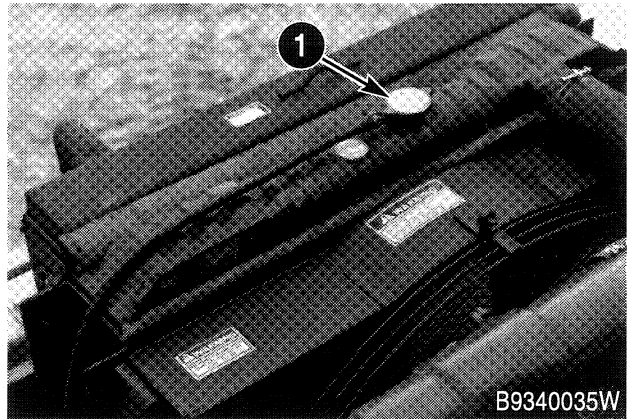

B9340035W

1. Radiator Cap

5. Open the access door for the batteries and disconnect the ground cable.

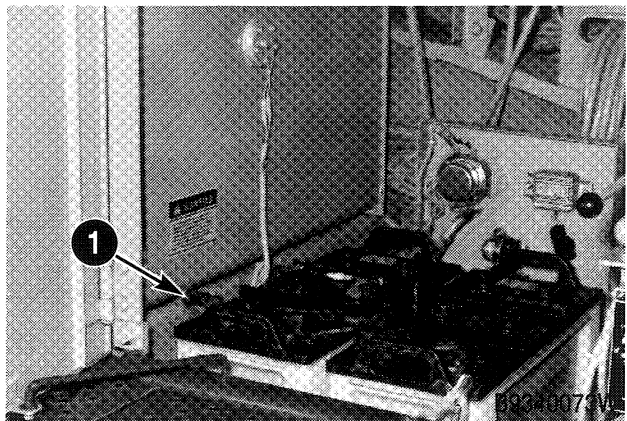

B9340079W

1. Ground Cable

6. Disconnect the hose for the air cleaner from the tube on the turbocharger (2).

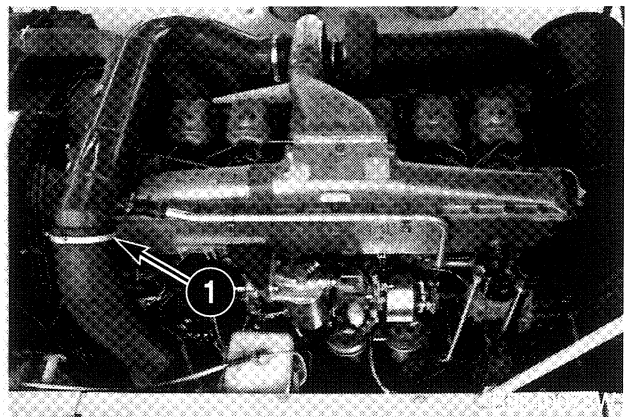

1. Disconnect hose here.

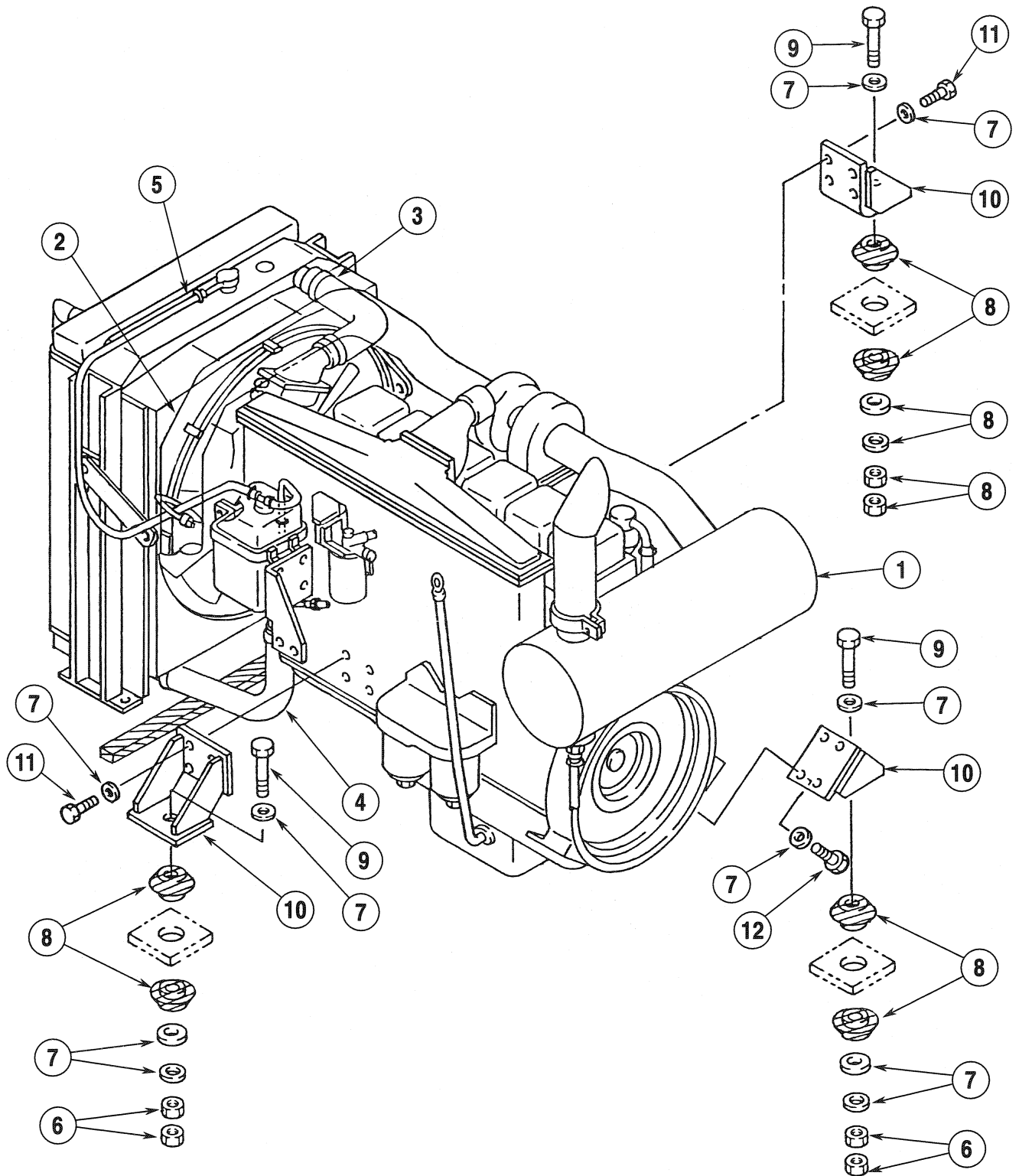

B9302264A

- 1. Muffler
- 2. Disconnect Hose for Air Cleaner Here.
- 3. Top Radiator Hose
- 4. Bottom Radiator Hose
- 5. Hose for the Coolant Reservoir
- 6. Self-Locking Nut

- 7. Washer
- 8. Insulator
- 9. Tighten to 213 to 249 pound-feet (289 to 337 Nm)
- 10. Engine Mounting Bracket
- 11. Tighten to 128 to 149 pound-feet (173 to 202 Nm)
- 12. Tighten to 197 to 230 pound-feet (267 to 312 Nm)

NOTE: Apply Loctite 262 on the threads of the bolts (9), and the cap screws (11 and 12).

7. Remove the muffler (1) and the mounting bracket for the muffler (1).
8. Disconnect the top (3) and bottom (4) radiator hoses from the radiator.
9. Disconnect the hose (5) for the coolant reservoir from the radiator.
10. Remove the fan guard and the fan shroud from the radiator.
11. Remove the cap screws and hardware that hold the fan and the spacer to the engine.
12. Disconnect the fuel supply hose and the fuel return hose. Install a plug in each hose.

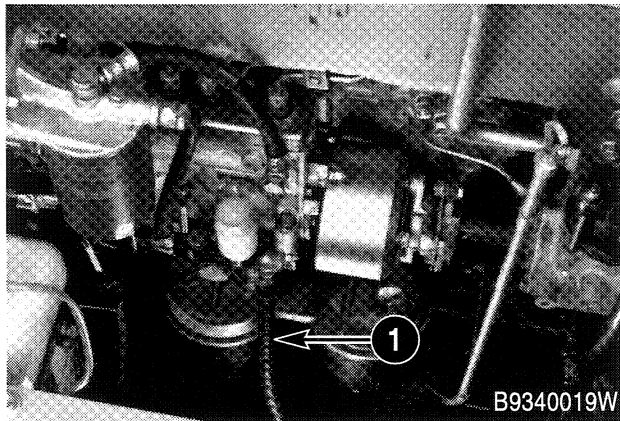

1. Supply Hose

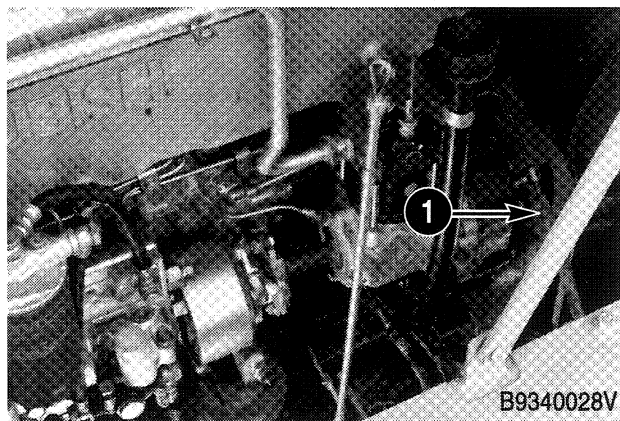

1. Return Hose

13. Disconnect the throttle cable and the shutoff cable from the fuel injection pump and the bracket on the engine. Put the throttle cable and the shutoff cable out of the way.

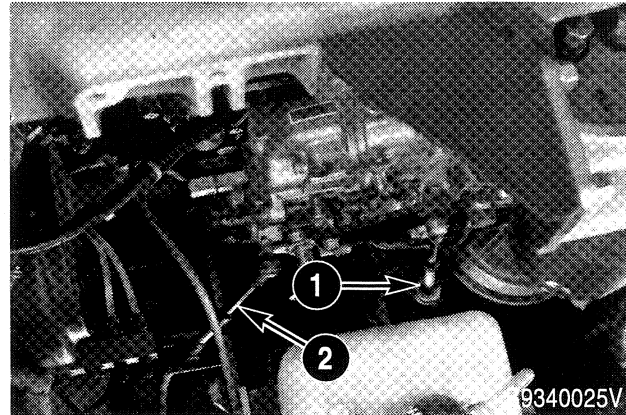

1. Throttle Cable

2. Shutoff Cable

14. Put identification tags on the wiring harness, wires and cables connected to the engine for correct assembly. Disconnect the wiring harness, wires and cables from the engine.
15. Disconnect the hoses for the heater from the engine. Install a plug in each hose.
16. Disconnect the ground strap from the engine.
17. Connect acceptable lifting equipment to the lifting eyes on the engine. The weight of the engine is 2392 pounds (1085 kg).
18. Rotate the flywheel and use the access hole in the housing of the hydraulic pump to remove the socket head screws that hold the coupling and drive plate to the flywheel.
19. Connect a lifting sling to the hydraulic pump. The weight of the hydraulic pump is 485 pounds (220 kg). Remove the cap screws and hardened washers that hold the hydraulic pump to the flywheel housing
20. Separate the hydraulic pump from the flywheel housing.
21. Remove the self-locking nuts (6), washers (7), insulators (8), and bolts (9) that hold the engine mounting brackets (10) to the frame.
22. Make sure that all hoses, tubes, cables, wires, and wiring harnesses are out of the way.
23. Lift the engine and remove the engine from the machine.

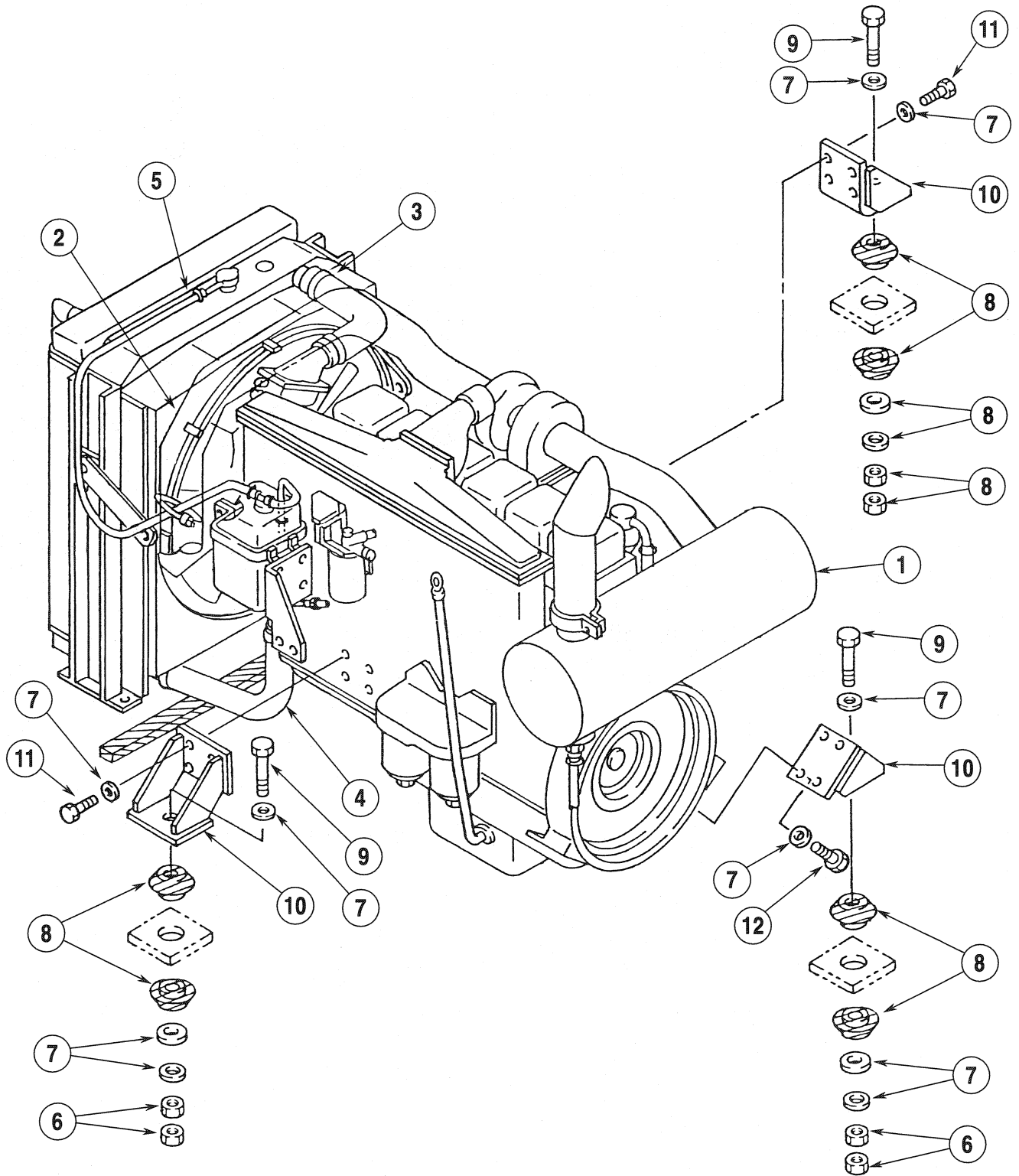

- 1. Muffler
- 2. Disconnect Hose for Air Cleaner Here
- 3. Top Radiator Hose
- 4. Bottom Radiator Hose
- 5. Hose for the Coolant Reservoir
- 6. Self-Locking Nut

- 7. Washer
- 8. Insulator
- 9. Tighten to 213 to 249 pound-feet (289 to 337 Nm)
- 10. Engine Mounting Bracket
- 11. Tighten to 128 to 149 pound-feet (173 to 202 Nm)
- 12. Tighten to 197 to 230 pound-feet (267 to 312 Nm)

NOTE: Apply Loctite 262 on the threads of the bolts (9), and the cap screws (11 and 12).

B9302264A

Installation

Installation is the reverse sequence of removal.

1. Check the condition of the insulators for the engine mounts. If the insulators are damaged, install new insulators.
2. Align the holes in the drive plate and coupling with the holes in the flywheel. Install the socket head screws that hold the coupling and drive plate to the flywheel. Tighten the socket head screws to the torque specifications shown on page 3. Loctite 262 must be applied on the threads of the socket head screws.
3. Tighten the bolts that hold the engine mounting brackets to the frame to the torque specifications shown on page 3. Loctite 262 must be applied on the threads of the bolts.
4. Tighten the cap screws that hold the hydraulic pump to the flywheel housing to the torque specifications shown on page 3. Loctite 262 must be applied on the threads in the holes in the flywheel housing.
5. Tighten the cap screws that hold the fan and the spacer to the engine to the torque specifications shown on page 3.

6. Do the following procedure to bleed the air from the cooling system.

- A. Close the drain valve on the radiator. Fill the radiator with coolant and fill the coolant reservoir to the fill neck. If new coolant is being installed, the coolant must be 55% ethylene glycol and 45% water.
- B. Install and tighten the cap for the coolant reservoir.

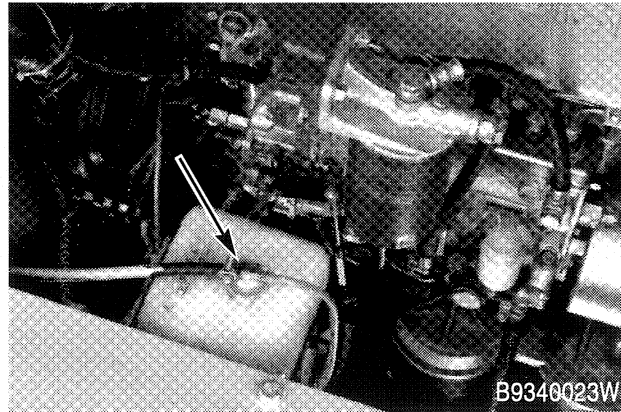

- C. Start and run the engine at low idle. Look at the water temperature gauge. When the water temperature gauge indicates normal operating temperature (4th or 5th amber bar illuminated), stop the engine and let the engine cool.
- D. Fill the radiator with coolant. Install and tighten the radiator cap.

Fill the coolant reservoir with coolant to the FULL mark. Install the cap for the coolant reservoir.

Section 2002

2002

RADIATOR REMOVAL AND INSTALLATION



TABLE OF CONTENTS

SPECIFICATIONS 2

RADIATOR 3

 Removal 3

 Installation 4

NOTE: The J I Case Company reserves the right to make improvements in design or changes in specifications at any time without incurring any obligation to install them on units previously sold.

SPECIFICATIONS

Cooling system capacity 12.7 U.S. gallons (48 litres)

Special torques

 Cap screws that hold the fan and spacer to the engine 38 to 45 pound-feet (51 to 61 Nm)

Weight of the radiator 441 pounds (200 kg)

RADIATOR

Removal

1. Park the machine on a hard level surface. Lower the tool to the floor and stop the engine.

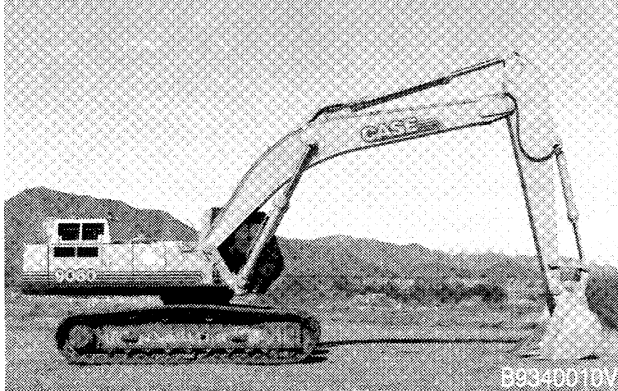

2. Open the access doors over the engine and on the right side of the engine compartment. Remove the access cover from under the radiator.

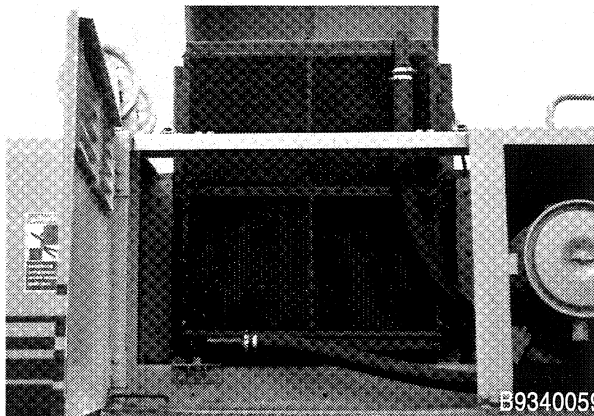

3. Make sure that the engine is cool and remove the radiator cap. Open the drain valve and drain the cooling system. The cooling system holds 12.7 U.S. gallons (48 litres) of coolant.



4. Disconnect the top and bottom radiator hoses from the radiator.
5. Disconnect the hose for the coolant reservoir from the radiator.
6. Remove the fan guard and the fan shroud from the radiator.
7. Remove the cap screws and hardware that hold the fan and the spacer to the engine. Remove the fan and the spacer.
8. Connect acceptable lifting equipment to the radiator. The weight of the radiator is 441 pounds (200 kg)
9. Remove the hardware that holds the radiator to the frame.
10. Remove the radiator from the machine.

Installation

Installation is the reverse sequence of removal.

1. If the foam baffles were removed from the radiator, install new foam baffles.
2. Tighten the cap screws that hold the fan and the spacer to the engine to the torque specifications shown on page 2.
3. Do the following procedure to bleed the air from the cooling system.

A. Close the drain valve on the radiator. Fill the radiator with coolant and fill the coolant reservoir to the fill neck. If new coolant is being installed, the coolant must be 55% ethylene glycol and 45% water.

B. Install and tighten the cap for the coolant reservoir.

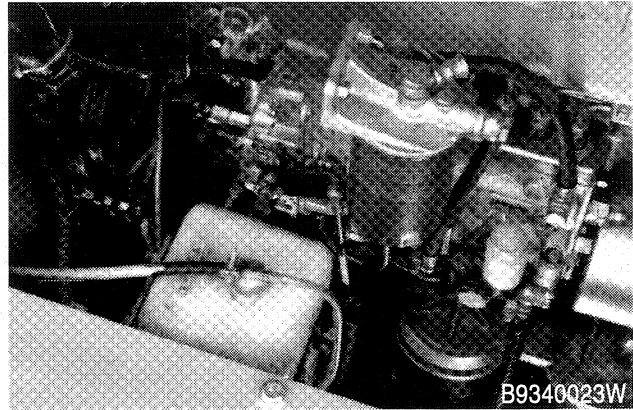

C. Start and run the engine at low idle. Look at the water temperature gauge. When the water temperature gauge indicates normal operating temperature (4th or 5th amber bar illuminated), stop the engine and let the coolant cool.

D. Fill the radiator with coolant. Install and tighten the radiator cap.

E. Fill the coolant reservoir with coolant to the FULL mark. Install the cap for the coolant reservoir.



Suggest:

If the above button click is invalid.

Please download this document

first, and then click the above link

to download the complete manual.

Thank you so much for reading

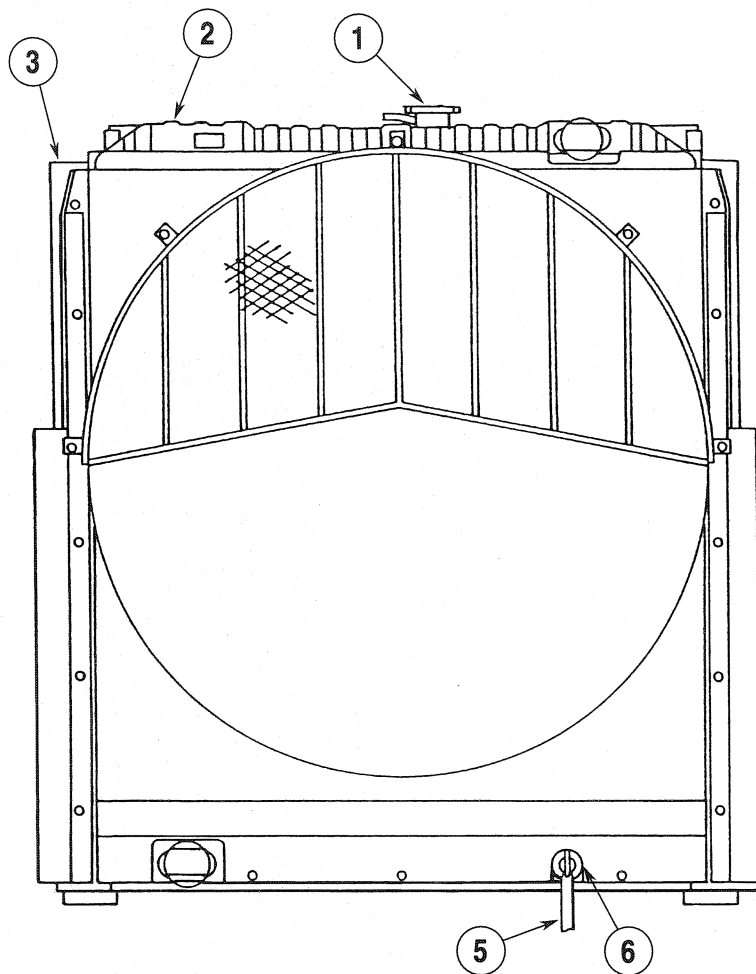

Front View of Fan Guard, Fan Shroud, and Radiator

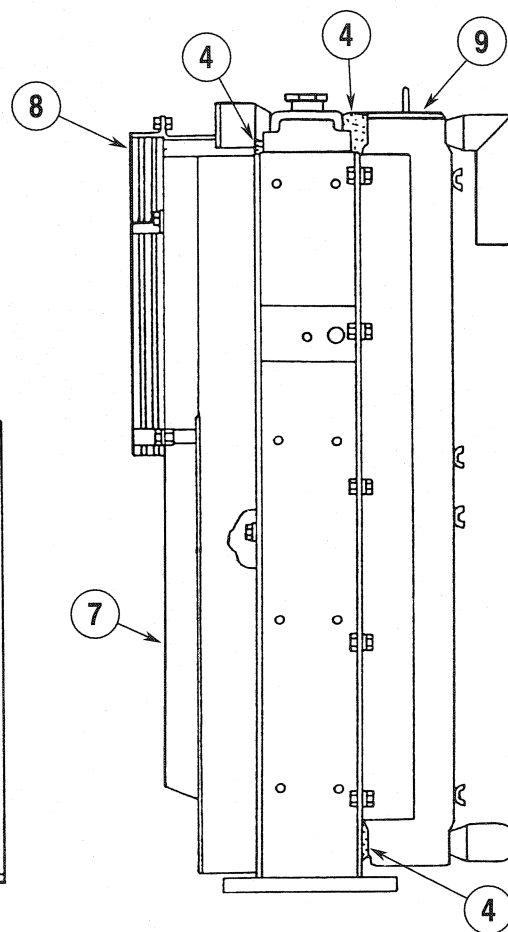

Side View of Fan Guard, Fan Shroud, Radiator and Oil Cooler

- | | | |
|-----------------|----------------|---------------|
| 1. Radiator Cap | 4. Foam Baffle | 7. Fan Shroud |
| 2. Radiator | 5. Drain Hose | 8. Fan Guard |
| 3. Frame | 6. Drain Valve | 9. Oil Cooler |

B9302259A

<https://www.ebooklibonline.com>

Hello dear friend!

Thank you very much for reading.

Enter the link into your browser.

The full manual is available for immediate download.

<https://www.ebooklibonline.com>