

**9030 Excavator
Service Manual
Table of Contents**

Description	Section No.	Form No.
General	Tab 1	
Section Index - General		7-44870
Standard Torque Specifications for 9000 Series Excavators	1001	7-44790
Fluids and Lubricants	1002	7-44800
Engines	Tab 2	
Section Index - Engines		7-44890
Engine Removal and Installation	2001	7-44900
Radiator Removal and Installation	2002	7-44910
Engine Specification Details	2401	8-26063
Cylinder Head and Valve Train	2415	8-26073
Cylinder Block	2425	8-26084
Lubrication System	2445	8-26093
Cooling System	2455	8-26103
Turbocharger	2465	8-26110
Turbocharger Failure Analysis	2565	9-78235
Fuel System	Tab 3	
Section Index - Fuel System		7-44920
Fuel System and Filters	3410	8-26131
Fuel Injection Pump, Bosch	3412	8-26143
Fuel Injectors	3413	8-26152
Electrical	Tab 4	
Section Index - Electrical		7-44930
Electrical Specifications and Troubleshooting	4001	7-44820
Electrical Schematic	In Rear Pocket	7-45200
Batteries	4002	7-44950
Systems Display Panel	4005	7-44980
Starter and Starter Solenoid	4006	8-42191
Alternator	4009	8-16570
Tracks	Tab 5	
Section Index - Tracks		7-44990
Troubleshooting the Track System	5001	7-44830
Tracks, Rollers, and Idlers	5002	7-45010
Power Train	Tab 6	
Section Index - Power Train		7-45020
Troubleshooting - See Section 8001		
Drive Motor and Final Drive Transmission	6000	7-45030

Reprinted

**9030 Excavator
Service Manual
Table of Contents**

Description	Section No.	Form No.
Hydraulics	Tab 8	
Section Index - Hydraulics		7-45040
Cleaning the Hydraulic System	8000	7-45050
Hydraulic Specifications, Troubleshooting, and Pressure Checks	8001	7-44840
Hydraulic Schematic Foldout	In Rear Pocket	7-45200
Main Hydraulic Pump	8002	7-45060
Pilot Control Circuit Pump	8003	7-45070
Hydraulic Swivel	8004	7-45080
Main Control Valve	8005	7-45090
Remote Control Valves	8006	7-45100
Solenoid Valves	8007	7-45110
Swing Motor and Swing Reduction Gear Box	8008	7-45120
Cylinders	8009	7-45130
Cushion Control Valve	8010	7-45180
Mounted Equipment	Tab 9	
Section Index - Mounted Equipment		7-45140
Pedals and Levers	9001	7-44850
Turntable Bearing	9003	7-44940
Boom and Arm	9004	7-45000
Seat and Seat Belts	9006	7-45170
Electrical Schematic Foldout	In Rear Pocket	7-45200
Hydraulic Schematic Foldout	In Rear Pocket	7-45200

Section 1001

STANDARD TORQUE SPECIFICATIONS FOR 9000 SERIES EXCAVATORS



Bur 7-44790

Copyright © 1992 CASE CORPORATION
Printed in U.S.A.
Issued November 1992

<https://www.ebooklibonline.com>

Hello dear friend!

Thank you very much for reading.

Enter the link into your browser.

The full manual is available for immediate download.

<https://www.ebooklibonline.com>

TABLE OF CONTENTS

TORQUE SPECIFICATIONS - DECIMAL HARDWARE2

TORQUE SPECIFICATIONS - METRIC HARDWARE3

TORQUE SPECIFICATIONS - STEEL HYDRAULIC FITTINGS4

TORQUE SPECIFICATIONS - O-RING FACE SEAL FITTINGS5

TORQUE SPECIFICATIONS - DECIMAL HARDWARE

Use the torques in this chart when special torques are not given. These torques apply to fasteners with both UNC and UNF threads as received from suppliers, dry, or when lubricated with engine oil. Not applicable if special graphites, molydisulfide greases, or other extreme pressure lubricants are used.

Grade 5 Bolts, Nuts, and Studs		
		
Size	Pound-Feet	Newton metres
1/4 in	9-11	12-15
5/16 in	17-21	23-28
3/8 in	35-42	48-57
7/16 in	54-64	73-87
1/2 in	80-96	109-130
9/16 in	110-132	149-179
5/8 in	150-180	203-244
3/4 in	270-324	366-439
7/8 in	400-480	542-651
1.0 in	580-696	787-944
1-1/8 in	800-880	1085-1193
1-1/4 in	1120-1240	1519-1681
1-3/8 in	1460-1680	1980-2278
1-1/2 in	1940-2200	2631-2983

Grade 8 Bolts, Nuts, and Studs		
		
Size	Pound-Feet	Newton metres
1/4 in	12-15	16-20
5/16 in	24-29	33-39
3/8 in	45-54	61-73
7/16 in	70-84	95-114
1/2 in	110-132	149-179
9/16 in	160-192	217-260
5/8 in	220-264	298-358
3/4 in	380-456	515-618
7/8 in	600-720	814-976
1.0 in	900-1080	1220-1465
1-1/8 in	1280-1440	1736-1953
1-1/4 in	1820-2000	2468-2712
1-3/8 in	2380-2720	3227-3688
1-1/2 in	3160-3560	4285-4827

NOTE: Use thick nuts with Grade 8 bolts.

TORQUE SPECIFICATIONS - METRIC HARDWARE

Use the following torques when specifications are not given.

These values apply to fasteners with coarse threads as received from supplier, plated or unplated, or when lubricated with engine oil. These values do not apply if graphite or molydisulfide grease or oil is used.

Grade 8.8 Bolts, Nuts, and Studs		
		
Size	Pound-Feet	Newton metres
M6	6-7	8-9
M8	14-17	20-23
M10	29-34	39-46
M12	50-59	68-80
M16	128-149	173-202
M20	249-291	337-393
M22	342-399	464-541
M24	431-503	584-681
M27	637-743	864-1008
M30	863-1007	1170-1365
M33	1180-1377	1600-1867
M36	1977-2307	2680-3127
M42	2434-2840	3300-3850
M45	3054-3563	4140-4830
M48	3658-4268	4960-5787
M52	4757-5549	6450-7525
M56	5908-6893	8010-9345
M64	8925-10413	12100-14117

Grade 10.9 Bolts, Nuts, and Studs		
		
Size	Pound-Feet	Newton metres
M6	8-10	11-13
M8	20-24	28-32
M10	41-47	55-64
M12	71-83	96-112
M16	178-208	242-282
M20	350-408	475-554
M22	481-561	652-761
M24	606-707	821-958
M27	900-1050	1220-1423
M30	1217-1420	1650-1925
M33	1667-1945	2260-2637
M36	2124-2478	2880-3360
M39	2773-3235	3760-4387
M42	3422-3992	4640-5413
M45	4293-5009	5820-6790
M48	5141-5998	6970-8132
M52	6690-7805	9070-10582
M56	8334-9723	11300-13183
M64	12612-14714	17100-19950

Grade 12.9 Bolts, Nuts, and Studs



Usually the torque values specified for grade 10.9 fasteners can be used satisfactorily on grade 12.9 fasteners.

TORQUE SPECIFICATIONS - STEEL HYDRAULIC FITTINGS

Tube OD Hose ID	Thread Size	Pound- Feet	Newton metres
37 Degree Flare Fittings			
1/4 in 6.4 mm	7/16-20	6-12	8-16
5/16 in 7.9 mm	1/2-20	8-16	11-22
3/8 in 9.5 mm	9/16-18	10-25	14-34
1/2 in 12.7 mm	3/4-16	15-42	20-57
5/8 in 15.9 mm	7/8-14	25-58	34-79
3/4 in 19.0 mm	1-1/16-12	40-80	54-108
7/8 in 22.2 mm	1-3/16-12	60-100	81-135
1.0 in 25.4 mm	1-5/16-12	75-117	102-158
1-1/4 in 31.8 mm	1-5/8-12	125-165	169-223
1-1/2 in 38.1 mm	1-7/8-12	210-250	285-338

Tube OD Hose ID	Thread Size	Pound- Feet	Newton metres
Straight Threads with O-ring			
1/4 in 6.4 mm	7/16-20	12-19	16-26
5/16 in 7.9 mm	1/2-20	16-25	22-34
3/8 in 9.5 mm	9/16-18	25-40	34-54
1/2 in 12.7 mm	3/4-16	42-67	57-91
5/8 in 15.9 mm	7/8-14	58-92	79-124
3/4 in 19.0 mm	1-1/16-12	80-128	108-174
7/8 in 22.2 mm	1-3/16-12	100-160	136-216
1.0 in 25.4 mm	1-5/16-12	117-187	159-253
1-1/4 in 31.8 mm	1-5/8-12	165-264	224-357
1-1/2 in 38.1 mm	1-7/8-12	250-400	339-542

Split Flange Mounting Bolts*		
Size	Pound- Feet	Newton metres
5/16-18	15-20	20-27
3/8-16	20-25	27-34
7/16-14	35-45	47-61
1/2-13	55-65	74-88
5/8-11	140-150	190-203

**NOTE: Use standard metric hardware torque for metric split flange mounting bolts.*

Section 2001

ENGINE REMOVAL AND INSTALLATION

ENGINE REMOVAL

1. Park the machine on a hard level surface. Lower the tool to the floor and stop the engine.

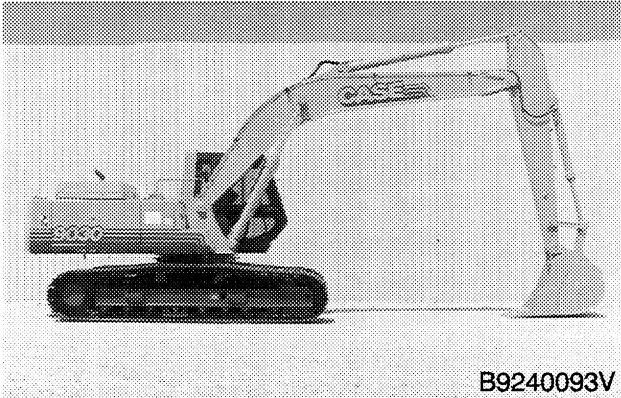

2. Open the access door over the engine and on each side of the engine compartment. Remove the access covers from under the engine and the radiator.

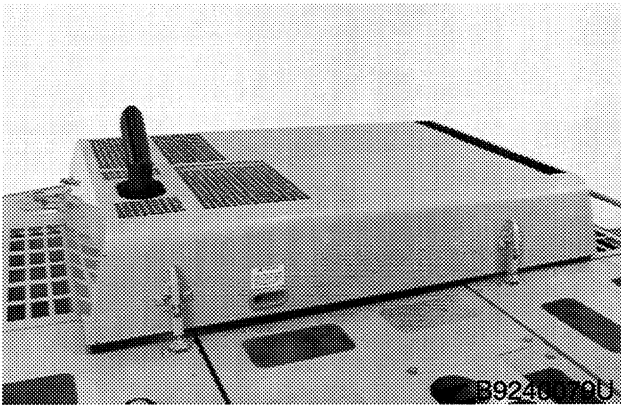

3. Make sure that the engine is cool and remove the radiator cap. Open the drain valve and drain the cooling system. The cooling system holds 7.1 U.S. gallons (26.8 litres) of coolant.

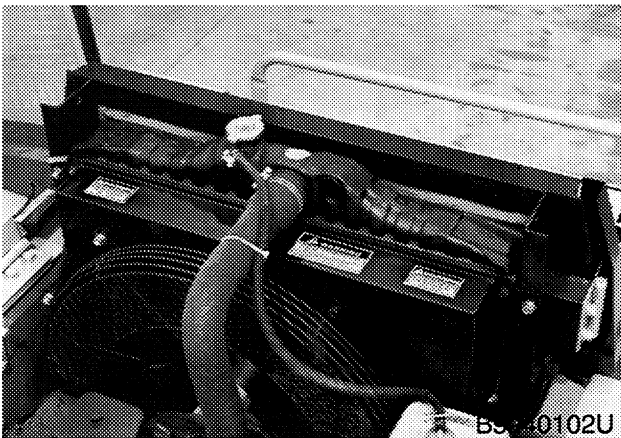

4. Raise the access cover for the batteries and disconnect the ground cable.

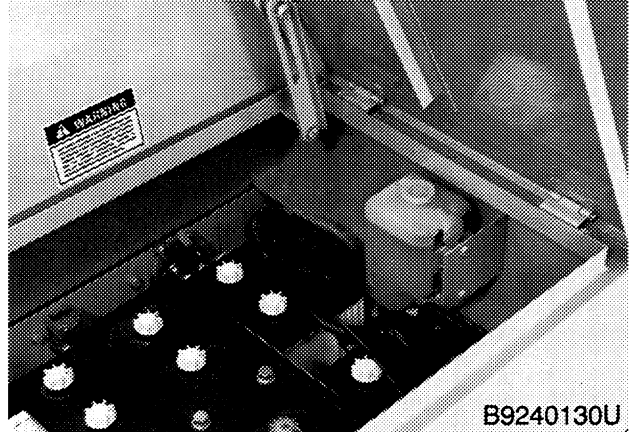

5. Remove the muffler and the mounting bracket for the muffler.

6. Disconnect the hose for the air cleaner from the turbocharger (1).

7. Disconnect the top (2) and bottom (3) radiator hoses from the radiator.

8. Disconnect the hose (4) for the coolant reservoir from the radiator.

9. Remove the fan guard and the fan shroud from the radiator.

10. Remove the cap screws (5) and hardware that hold the fan (6) and the spacer to the engine.

11. Disconnect the fuel supply hose and the fuel return hose. Install a plug in each hose.

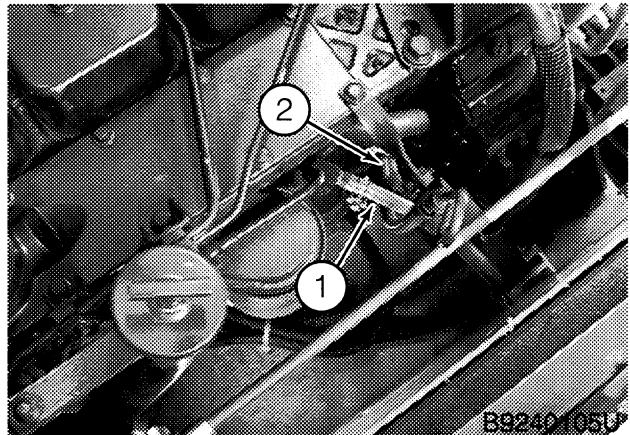

- 1. Supply Hose
- 2. Return Hose

12. Disconnect the throttle cable from the arm on the fuel injection pump and the bracket on the engine. Put the throttle cable out of the way. If the machine is equipped with either injection, disconnect the tube from the fitting.

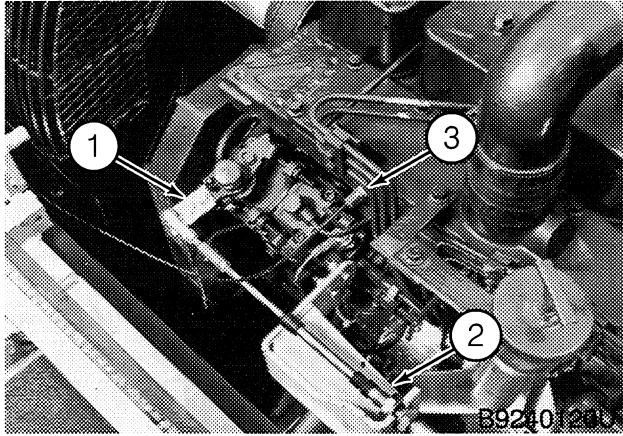

1. Arm

2. Bracket

3. Fitting

13. Put identification tags on the wiring harness, wires and cables connected to the engine for correct assembly. Disconnect the wiring harness, wires and cables from the engine.

14. Disconnect the hoses for the heater from the engine. Install a plug in each hose.

15. Disconnect the ground strap from the engine.

16. Connect acceptable lifting equipment to the lifting eyes on the engine. The weight of the engine is 967 pounds (439 kg).

17. Connect a lifting sling to the hydraulic pump. The weight of the hydraulic pump is 287 pounds (130 kg). Remove the cap screws and hardened washers that hold the hydraulic pump to the flywheel housing.

18. Separate the hydraulic pump from the flywheel housing.

19. Remove the self-locking nuts (7), washers (8), insulators (9), and bolts (10) that hold the engine mounting brackets (11) to the frame.

20. Make sure that all hoses, tubes, cables, wires, and wiring harnesses are out of the way.

21. Lift the engine and remove the engine from the machine.

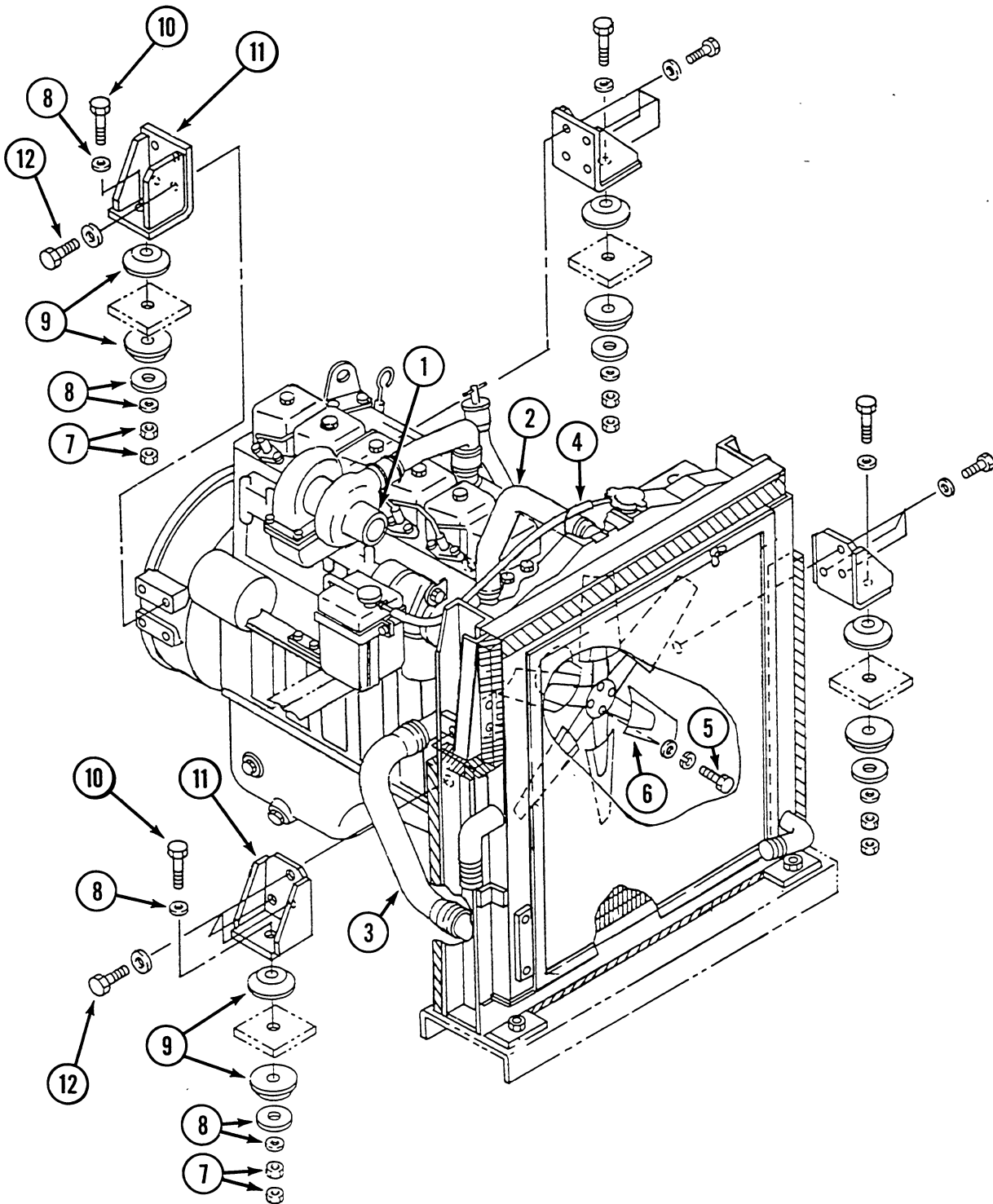

- 1. Disconnect Hose For Air Cleaner Here
- 2. Top Radiator Hose
- 3. Bottom Radiator Hose
- 4. Hose For the Coolant Reservoir
- 5. Tighten to 38 to 45 pound-feet
(51 to 61 Nm)
- 6. Fan
- 7. Self-locking Nut

- 8. Washer
- 9. Insulator
- 10. Tighten to 198 to 231 pound-feet
(268 to 313 Nm)
- 11. Engine Mounting Bracket
- 12. Tighten to 48 to 56 pound-feet
(65 to 76 Nm)

B922288J

ENGINE INSTALLATION

Installation is the reverse sequence of removal.

1. Check the condition of the insulators for the engine mounts. If the insulators are damaged, install new insulators.

2. Use the CAS-1690 tool to rotate the flywheel and align the pins in the flywheel with the holes in the coupling on the drive shaft of the hydraulic pump. See Section 8002.

3. Tighten the bolts that hold the engine mounting brackets to the frame to the torque specification shown on page 3.

4. Tighten the cap screws that hold the hydraulic pump to the flywheel housing to the torque specification shown on page 3. Loctite 262 must be applied on the threads in the holes in the flywheel housing.

5. Tighten the cap screws that hold the fan and the spacer to the engine to the torque specification shown on page 3.

6. Do the following procedure to bleed the air from the cooling system.

a. Close the drain valve on the radiator. Fill the radiator with coolant and fill the coolant reservoir to the fill neck. If new coolant is being installed, the coolant must be 55% ethylene glycol and 45% water.

b. Install and tighten the radiator cap.

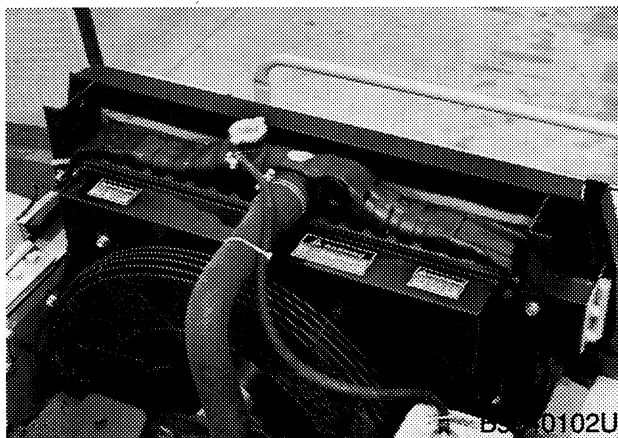

c. Install and tighten the cap for the coolant reservoir.

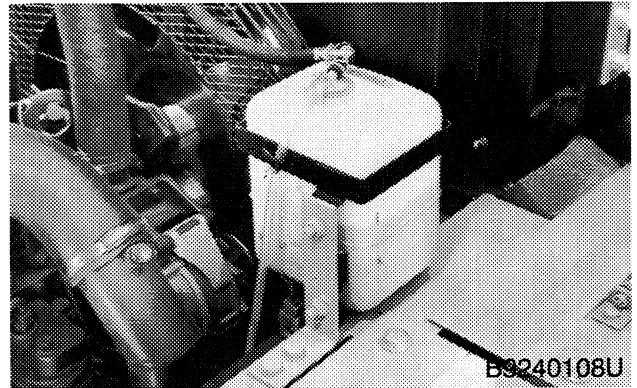

d. Close the shutoff valve for the heater at the top rear of the engine.

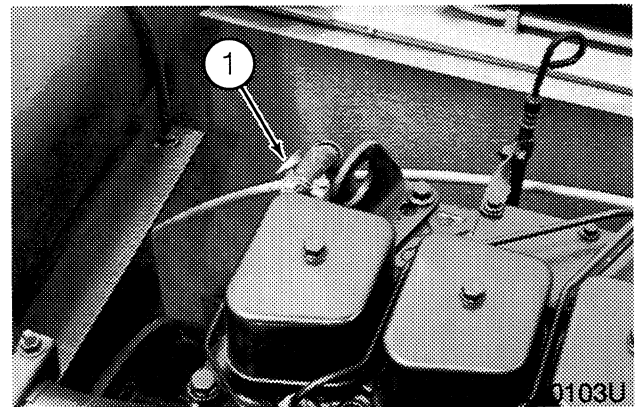

e. Start and run the engine at low idle for one minute.

f. Stop the engine. Fill the radiator with coolant again and fill the coolant reservoir again.

g. Cover the outside of the radiator core (the side away from the fan) with cardboard.

h. Start and run the engine at high idle. Look at the water temperature gauge. When the water temperature gauge indicates normal operating temperature (4th or 5th amber bar illuminated), open the shutoff valve for the heater.

i. Continue to run the engine until the last amber bar illuminates, then remove the cardboard from the radiator.

Continued on next page

j. Reduce the engine speed to low idle. Continue to run the engine at low idle for 30 seconds.

k. Stop the engine and let the coolant cool.

l. When the radiator feels COLD, remove the radiator cap and the cap for the coolant reservoir.

m. Fill the radiator with coolant. Install and tighten the radiator cap.

n. Fill the coolant reservoir with coolant to the FULL mark. Install the cap for the coolant reservoir.

TABLE OF CONTENTS

SPECIFICATIONS.....2

RADIATOR REMOVAL.....2

RADIATOR INSTALLATION.....3

SPECIFICATIONS

Cooling system capacity..... 7.1 U.S. gallons (26.8 litres)

Special torques

Cap screws that hold the fan and the spacer to the engine..... 38 to 45 pound-feet (51 to 61 Nm)

RADIATOR REMOVAL

1. Park the machine on a hard level surface. Lower the tool to the floor and stop the engine.

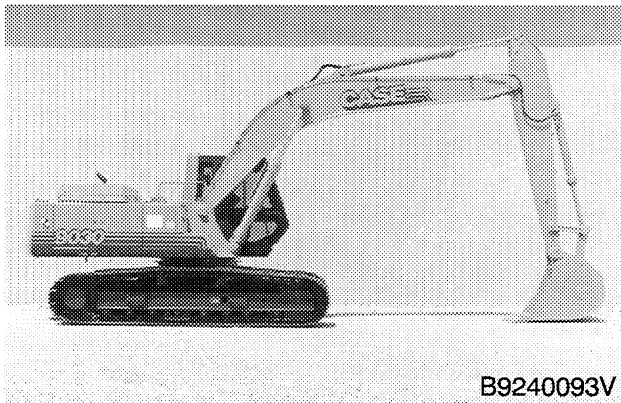

2. Open the access door over the engine and on the left side of the engine compartment. Remove the access cover from under the radiator.

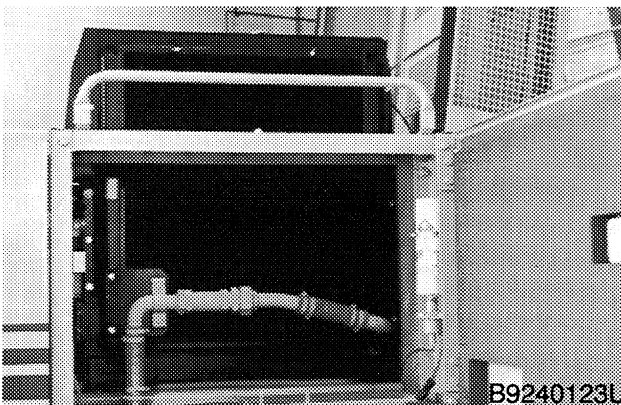

3. Make sure that the engine is cool and remove the radiator cap. Open the drain valve and drain the cooling system. The cooling system holds 7.1 U.S. gallons (26.8 litres) of coolant.

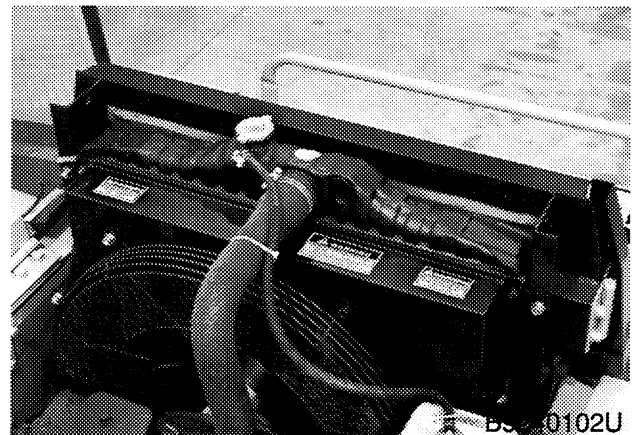

4. Disconnect the top and bottom radiator hoses from the radiator.

5. Disconnect the hose for the coolant reservoir from the radiator.

6. Remove the fan guard and the fan shroud from the radiator.

7. Remove the cap screws and hardware that hold the fan and the spacer to the engine. Remove the fan and the spacer.

8. Connect acceptable lifting equipment to the radiator.

9. Remove the hardware that holds the radiator to the frame.

10. Remove the radiator from the machine.

RADIATOR INSTALLATION

Installation is the reverse sequence of removal.

1. If the foam baffles were removed from the radiator, install new foam baffles.
2. Tighten the cap screws that hold the fan and the spacer to the engine to the torque specification shown on page 2.
3. Do the following procedure to bleed the air from the cooling system.

a. Close the drain valve on the radiator. Fill the radiator with coolant and fill the coolant reservoir to the fill neck. If new coolant is being installed, the coolant must be 55% ethylene glycol and 45% water.

b. Install and tighten the radiator cap.

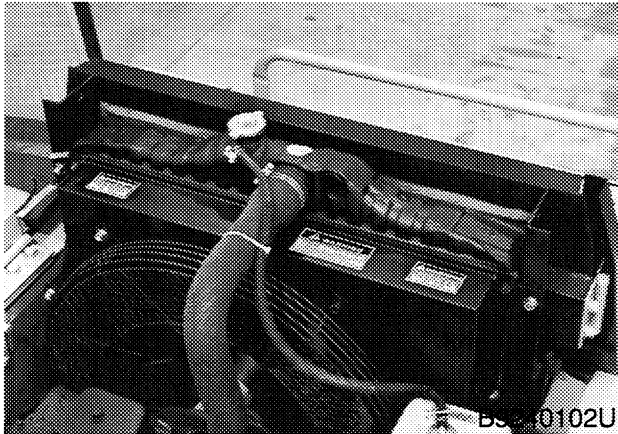

c. Install and tighten the cap for the coolant reservoir.

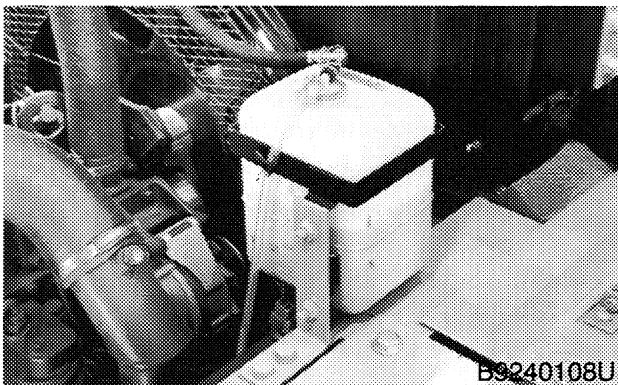

d. Close the shutoff valve for the heater at the top rear of the engine.

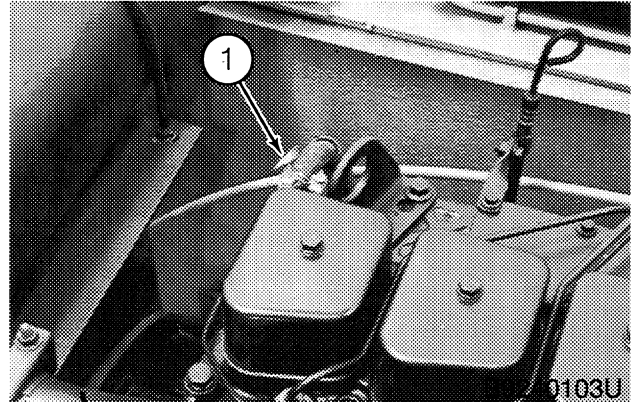

1. Shutoff Valve

e. Start and run the engine at low idle for one minute.

f. Stop the engine. Fill the radiator with coolant again and fill the coolant reservoir again.

g. Cover the outside of the radiator core (the side away from the fan) with cardboard.

h. Start and run the engine at high idle. Look at the water temperature gauge. When the water temperature gauge indicates normal operating temperature (4th or 5th amber bar illuminated), open the shutoff valve for the heater.

i. Continue to run the engine until the last amber bar illuminates, then remove the cardboard from the radiator.

j. Reduce the engine speed to low idle. Continue to run the engine at low idle for 30 seconds.

k. Stop the engine and let the coolant cool.

l. When the radiator feels COLD, remove the radiator cap and the cap for the coolant reservoir.

m. Fill the radiator with coolant. Install and tighten the radiator cap.

n. Fill the coolant reservoir with coolant to the FULL mark. Install the cap for the coolant reservoir.

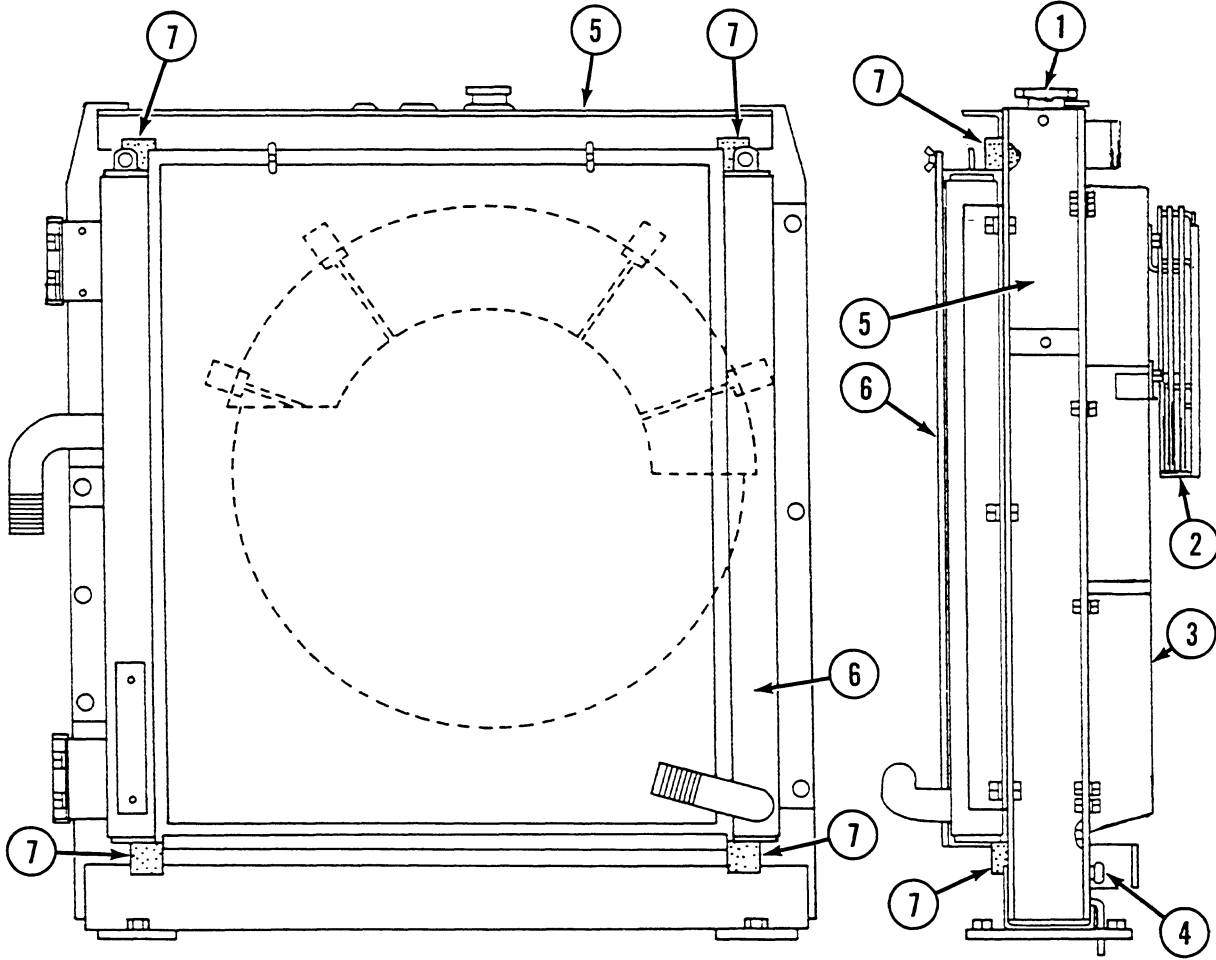

B923377J

Front View of Oil Cooler and Radiator

Side View Of Oil Cooler
And Radiator

1. Radiator Cap
2. Fan Guard

3. Fan Shroud
4. Drain Valve

5. Radiator
6. Oil Cooler

7. Foam Baffle

RUN-IN INSTRUCTIONS

Engine Lubrication

Fill the 6-590 engine crankcase with CC/SF, CD/SF, CE/SF or CF-4 service classification oil. Use the correct viscosity rating for the ambient air temperature. Install new oil filters after the engine is rebuilt.

Fill the 6T590 and the 6TA 590 engine crankcase with CE/SF or CF-4 service classification oil. Use the correct viscosity rating for the ambient air temperature. Install new oil filters after the engine is rebuilt.

Run-In Procedure for Rebuilt Engine

- Step 1 Disconnect the wire to the electric shut-off on the injection pump so that the engine will not start. Crank the engine for 30 seconds until there is oil pressure, then reconnect the wire.
- Step 2 Remove the air from the cooling system at the temperature sending unit.
- Step 3 Run the engine at 1000 RPM minimum load for 5 minutes and check for oil leaks.
- Step 4 During the Run-In, continue to check the oil pressure, coolant level, and coolant temperature.

Run-In Procedure for Rebuilt Engines (with a Dynamometer)

The following procedure must be followed when using a PTO dynamometer to Run-In the engine. The dynamometer will control the engine load at each speed and will remove stress on new parts during Run-In.

During the Run-In, continue to check the oil pressure, coolant level and coolant temperature.

STEP	TIME	ENGINE SPEED	DYNAMOMETER SCALE LOAD
1	5 Minutes	1000 RPM	50
2	5 Minutes	1100 RPM	1/2
3	5 Minutes	2200 RPM	Full

Run-In Procedure for Rebuilt Engines (without a Dynamometer)

STEP	TIME	ENGINE SPEED	LOAD
1	5 Minutes	1000 RPM	No Load
2	5 Minutes	1100 RPM	Light Load
3	5 Minutes	2200 RPM	Light Load

Run-In Procedure (Agriculture Equipment)

For the first 8 hours of field operation stay one gear lower than normal. For the next 12 hours DO NOT "lug" the engine. Prevent "lugging" by moving the lever to a lower gear. The engine must not be "lugged" below the rated engine RPM during early hours of life.

Run-In Procedure (Construction Equipment)

For the first 8 hours, operate the engine at full throttle maintaining a normal load. Avoid converter or hydraulic stall. The engine must not be "lugged" below the Rated Engine RPM (Do not stall the engine more than 10 seconds).

IDENTIFICATION MARKS

Crankshaft

Letter N = Nitroc Hardened, crankshaft must be rehardened to a minimum hardness of 450 HV 0.2 rockwell any time the crankshaft has been reconditioned.

Cylinder Block

Letter X = The cylinder block has been refaced and up to 0.25 mm has been removed. Use a thicker head gasket (two notches).

Letter XX = The cylinder block has been refaced and up to 0.50 mm has been removed. Use a thicker head gasket (three notches).

Cylinder Head

Letter G = Thermostat passage in cylinder did not need to be machined.

Letter M = Thermostat passage in cylinder head was machined.

Letter V = Valve seats have been machined.

Letter X = The cylinders in the cylinder block have been bored oversize. Use this gasket for standard replacement and oversize cylinder holes (one notch).

Letter XX = The cylinder block has been refaced and up to 0.25 mm has been removed use a thicker head gasket (two notches).

Letter XXX = The cylinder block has been refaced and up to 0.50 mm has been removed. Use a thicker head gasket (three notches).

Numbers = RH rear corner of cylinder head indicates the amount of material removed from the cylinder head.

ENGINE SPECIFICATION DETAILS

Cylinder Block

	Metric Value
Type.....	Non-Sleeved
Material.....	Cast Iron
ID of Cylinder	102.00 to 102.04 mm
Maximum Service Limit	102.116 mm
Cylinder Out of Round (Maximum).....	0.038 mm
Cylinder Taper (Maximum).....	0.076 mm
0.5 mm Oversize Piston	
Machine Cylinder Bore to.....	102.40 to 102.44 mm
Hone to (Finished Diameter)	102.50 to 102.54 mm
1.00 mm Oversize Piston	
Machine Cylinder Bore to.....	102.90 to 102.94 mm
Hone to (Finished Diameter)	103.00 to 103.04 mm
Warpage (Maximum).....	0.075 mm
Maximum Material Removal.....	0.50 mm

Service Cylinder Sleeve

Type.....	Dry, Can Be Replaced
Material.....	Cast Iron
Machine Cylinder Block Bore to	104.485 to 104.515 mm
Installation	Press Fit
Machine Sleeve Bore to:	
Standard Size Piston (Finished Diameter)	102.00 to 102.04 mm
0.5 mm Oversize Piston	
Machine Cylinder Bore to	102.40 to 102.44 mm
Hone to (Finished Diameter)	102.50 to 102.54 mm
1.0 mm Oversize Piston	
Machine Cylinder Bore to	102.90 to 102.94 mm
Hone to (Finished Diameter)	103.00 to 103.04 mm
Main Bearing Bolt Maximum Length	119.25 mm

Piston

Type.....	Cam Ground
Material.....	Aluminum Alloy
OD at 12 mm From the Bottom, 90 Degrees Piston Pin	
Standard Size Piston	101.873 to 101.887 mm
Minimum Service Limit.....	101.823 mm
0.5 mm Oversize Piston	102.373 to 102.387 mm
Minimum Service Limit.....	101.323 mm
1.0 mm Oversize Piston	102.873 to 102.887 mm
Minimum Service Limit.....	102.823 mm
ID of Piston Pin Bore.....	40.006 to 40.012 mm
Maximum Service Limit	40.025 mm
Width of 1st Ring Groove (Top).....	2.465 to 2.485 mm
Width of 2nd Ring Groove (Intermediate).....	2.425 to 2.445 mm
Width of 3rd Ring Groove (Oil Ring)	4.040 to 4.060 mm
Protrusion Above Cylinder Block (Maximum)	0.660 mm

Piston Pin

Type.....	Full Float
OD of Pin.....	39.997 to 40.003 mm
Minimum Service Limit	39.990 mm

Piston Rings

No. 1 Compression 6T-590 and 6TA-590 Engine.....	Key Stone Type (Barrel Face)
End Gap in 102.02 ID	0.4 to 0.70 mm
No. 1 Compression 6-590 Engine.....	Rectangular Type (Barrel Face)
End Gap in 102.02 ID	0.25 to 0.55 mm
Maximum Service Limit.....	0.806 mm
Side Clearance	0.075 to 0.120 mm
Maximum Service Limit.....	0.15 mm
No. 2 Compression.....	Rectangular Type (Tapper Face)
End Gap in 102.02 ID	0.25 to 0.55 mm
Maximum Service Limit.....	0.806 mm
Side Clearance	0.075 to 0.120 mm
Maximum Service Limit.....	0.15 mm
No. 3 Oil Control Rings.....	Two Piece
End Gap in 102.02 ID	0.25 to 0.55 mm
Maximum Service Limit.....	0.806 mm
Side Clearance	0.130 mm

Cylinder Head

Warpage (Maximum).....	0.20 mm
Maximum Material Removal.....	1.00 mm
Minimum Head Height	93.75 mm

Engines Manufactured in U.S.A.:

Prior to Engine Serial Number 45511034	Injector Nozzle 9 mm
Engine Serial Number 45511034 and After	Injector Nozzle 7 mm

Engines Manufactured in Darlington England:

Prior to Engine Serial Number 21092870	Injector Nozzle 9 mm
Engine Serial Number 21092870 and After	Injector Nozzle 7 mm

Engines Manufactured in Neuss Germany:

Prior to Engine Serial Number 52107489	Injector Nozzle 9 mm
Engine Serial Number 52107489 and After	Injector Nozzle 7 mm

Lifters

Material.....	Hardened Iron
OD of Lifter	15.961 to 15.977 mm
Minimum Service Limit.....	15.960 mm
Bore Diameter in Block	16.000 to 16.030 mm
Maximum Service Limit.....	16.055 mm



Suggest:

If the above button click is invalid.

Please download this document

first, and then click the above link

to download the complete manual.

Thank you so much for reading

Cylinder Block

Maximum (Warpage).....	0.075 mm
Maximum Material Removal.....	0.50 mm

Connecting Rod

Bushing	Steel Backed Leaded Bronze
Bushing ID Installed (Ream to Size).....	40.053 to 40.067 mm
Maximum Service Limit	40.092 mm
Bearing Liners	Replaceable
Journal ID Without Bearing Liners	72.987 to 73.013 mm
Bearing Oil Clearance.....	0.038 to 0.116 mm
Maximum Service Limit	0.129 mm
Side Clearance.....	0.100 to 0.300 mm
Maximum Service Limit	0.330 mm
Connecting Rod Bend (Maximum)	
Without Bushing	0.200 mm
With Bushing	0.150 mm
Connecting Rod Twist (Maximum)	
Without Bushing	0.500 mm
With Bushing	0.300 mm
Connecting Rod Bolt Maximum Length.....	59.25 mm

<https://www.ebooklibonline.com>

Hello dear friend!

Thank you very much for reading.

Enter the link into your browser.

The full manual is available for immediate download.

<https://www.ebooklibonline.com>