

2050M
Tier 4B (final)
Crawler Dozer
PIN NGC109000 and above

SERVICE MANUAL

Part number 48048570

1st edition English

April 2017





SERVICE MANUAL

2050M Extra Long Track (XLT), Bulldozer (BD) Blade - Tier 4B (final) and Stage IIIB [NGC109000 -], 2050M Extra Long Track (XLT), Power Angle Tilt (PAT) Blade - Tier 4B (final) and Stage IIIB [NGC109000 -], 2050M Long Track (LT), Bulldozer (BD) Blade - Tier 4B (final) and Stage IIIB [NGC109000 -], 2050M Long Track (LT), Power Angle Tilt (PAT) Blade - Tier 4B (final) and Stage IIIB [NGC109000 -], 2050M Wide Track (WT) / Low Ground Pressure (LGP), Bulldozer (BD) Blade - Tier 4B (final) and Stage IIIB [NGC109000 -], 2050M Wide Track (WT) / Low Ground Pressure (LGP), Power Angle Tilt (PAT) Blade - Tier 4B (final) and Stage IIIB [NGC109000 -]

Contents

INTRODUCTION

Engine.....	10
[10.001] Engine and crankcase	10.1
[10.216] Fuel tanks	10.2
[10.206] Fuel filters	10.3
[10.202] Air cleaners and lines	10.4
[10.250] Turbocharger and lines.....	10.5
[10.500] Selective Catalytic Reduction (SCR) exhaust treatment.....	10.6
[10.400] Engine cooling system	10.7
[10.414] Fan and drive	10.8
[10.310] Aftercooler.....	10.9
[10.304] Engine lubrication system.....	10.10
Hydrostatic drive.....	29
[29.218] Pump and motor components.....	29.1
Brakes and controls	33
[33.110] Parking brake or parking lock	33.1
[33.202] Hydraulic service brakes	33.2
Hydraulic systems.....	35
[35.300] Reservoir, cooler, and filters.....	35.1
[35.104] Fixed displacement pump.....	35.2
[35.106] Variable displacement pump	35.3
[35.105] Charge pump.....	35.4
[35.359] Main control valve.....	35.5
[35.741] Dozer blade cylinders	35.6
[35.525] Auxiliary hydraulic valves and lines	35.7
[35.752] Hydraulic fan drive cooling system.....	35.8

<https://www.ebooklibonline.com>

Hello dear friend!

Thank you very much for reading.

Enter the link into your browser.

The full manual is available for immediate download.

<https://www.ebooklibonline.com>

[35.000] Hydraulic systems	35.9
Frames and ballasting	39
[39.100] Frame	39.1
Tracks and track suspension	48
[48.130] Track frame and driving wheels	48.1
[48.100] Tracks	48.2
[48.134] Track tension units	48.3
[48.138] Track rollers	48.4
[48.AAA] Tracks and track suspension generic sub-group	48.5
[48.140] Dropbox and final drive	48.6
Cab climate control	50
[50.100] Heating	50.1
[50.104] Ventilation	50.2
[50.200] Air conditioning	50.3
Electrical systems	55
[55.000] Electrical system	55.1
[55.011] Fuel tank system	55.2
[55.015] Engine control system	55.3
[55.030] Service brake electrical system	55.4
[55.050] Heating, Ventilation, and Air-Conditioning (HVAC) control system	55.5
[55.100] Harnesses and connectors	55.6
[55.201] Engine starting system	55.7
[55.202] Cold start aid	55.8
[55.301] Alternator	55.9
[55.302] Battery	55.10
[55.408] Warning indicators, alarms, and instruments	55.11
[55.512] Cab controls	55.12
[55.518] Wiper and washer system	55.13

[55.988] Selective Catalytic Reduction (SCR) electrical system	55.14
[55.DTC] FAULT CODES.....	55.15
Dozer blade and arm.....	86
[86.110] Dozer blade	86.1
[86.124] Dozer pushbeams and struts	86.2
Tools	89
[89.128] Ripper assembly	89.1
Platform, cab, bodywork, and decals.....	90
[90.150] Cab.....	90.1
[90.114] Operator protections	90.2
[90.124] Pneumatically-adjusted operator seat.....	90.3
[90.100] Engine hood and panels	90.4



INTRODUCTION

Safety rules

2050M

NA

Personal safety





This is the safety alert symbol. It is used to alert you to potential personal injury hazards. Obey all safety messages that follow this symbol to avoid possible death or injury.

Throughout this manual you will find the signal words DANGER, WARNING, and CAUTION followed by special instructions. These precautions are intended for the personal safety of you and those working with you.

Read and understand all the safety messages in this manual before you operate or service the machine.

 DANGER indicates a hazardous situation that, if not avoided, will result in death or serious injury.

 WARNING indicates a hazardous situation that, if not avoided, could result in death or serious injury.

 CAUTION indicates a hazardous situation that, if not avoided, could result in minor or moderate injury.

FAILURE TO FOLLOW DANGER, WARNING, AND CAUTION MESSAGES COULD RESULT IN DEATH OR SERIOUS INJURY.

Machine safety

NOTICE: Notice indicates a situation that, if not avoided, could result in machine or property damage.

Throughout this manual you will find the signal word Notice followed by special instructions to prevent machine or property damage. The word Notice is used to address practices not related to personal safety.

Information

NOTE: Note indicates additional information that clarifies steps, procedures, or other information in this manual.

Throughout this manual you will find the word Note followed by additional information about a step, procedure, or other information in the manual. The word Note is not intended to address personal safety or property damage.

Safety rules - Personal safety

2050M

NA

General maintenance safety

Keep the area used for servicing the machine clean and dry. Clean up spilled fluids.

Service the machine on a firm, level surface.

Install guards and shields after you service the machine.

Close all access doors and install all panels after servicing the machine.

Do not attempt to clean, lubricate, clear obstructions, or make adjustments to the machine while it is in motion or while the engine is running.

Always make sure that working area is clear of tools, parts, other persons and pets before you start operating the machine.

Unsupported hydraulic cylinders can lose pressure and drop the equipment, causing a crushing hazard. Do not leave equipment in a raised position while parked or during service, unless the equipment is securely supported.

Jack or lift the machine only at jack or lift points indicated in this manual.

Incorrect towing procedures can cause accidents. When you tow a disabled machine follow the procedure in this manual. Use only rigid tow bars.

Stop the engine, remove the key, and relieve pressure before you connect or disconnect fluid lines.

Stop the engine and remove the key before you connect or disconnect electrical connections.

Scalding can result from incorrect removal of coolant caps. Cooling systems operate under pressure. Hot coolant can spray out if you remove a cap while the system is hot. Allow the system to cool before you remove the cap. When you remove the cap, turn it slowly to allow pressure to escape before you completely remove the cap.

Replace damaged or worn tubes, hoses, electrical wiring, etc.

The engine, transmission, exhaust components, and hydraulic lines may become hot during operation. Take care when you service such components. Allow surfaces to cool before you handle or disconnect hot components. Wear protective equipment when appropriate.

When welding, follow the instructions in the manual. Always disconnect the battery before you weld on the machine. Always wash your hands after you handle battery components.

General battery safety

Always wear eye protection when you work with batteries.

Do not create sparks or have open flame near a battery.

Ventilate the area when you charge a battery or use a battery in an enclosed area.

Disconnect the negative (-) terminal first and reconnect the negative (-) terminal last.

When you weld on the machine, disconnect both terminals of the battery.

Do not weld, grind, or smoke near a battery.

When you use auxiliary batteries or connect jumper cables to start the engine, use the procedure shown in the operator's manual. Do not short across terminals.

Follow the manufacturer's instructions when you store and handle batteries.

Battery post, terminals, and related accessories contain lead and lead compounds. Wash hands after handling. This is a California Proposition 65 warning.

Battery acid causes burns. Batteries contain sulfuric acid. Avoid contact with skin, eyes, or clothing. Antidote (external): Flush with water. Antidote (eyes): flush with water for 15 minutes and seek medical attention immediately. Antidote (internal): Drink large quantities of water or milk. Do not induce vomiting. Seek medical attention immediately.

Keep out of reach of children and other unauthorized persons.

Air-conditioning system

The air-conditioning system is under high pressure. Do not disconnect any lines. The release of high pressure can cause serious injury.

The air-conditioning system contains gases that are harmful to the environment when released into the atmosphere. Do not attempt to service or repair the system.

Only trained service technicians can service, repair, or recharge the air-conditioning system.

Personal Protective Equipment (PPE)

Wear Personal Protective Equipment (PPE) such as hard hat, eye protection, heavy gloves, hearing protection, protective clothing, etc.

Do Not Operate tag

Before you start servicing the machine, attach a 'Do Not Operate' warning tag to the machine in an area that will be visible.



SERVICE MANUAL

Engine

2050M Extra Long Track (XLT), Bulldozer (BD) Blade - Tier 4B (final) and Stage IIIB [NGC109000 -], 2050M Extra Long Track (XLT), Power Angle Tilt (PAT) Blade - Tier 4B (final) and Stage IIIB [NGC109000 -], 2050M Long Track (LT), Bulldozer (BD) Blade - Tier 4B (final) and Stage IIIB [NGC109000 -], 2050M Long Track (LT), Power Angle Tilt (PAT) Blade - Tier 4B (final) and Stage IIIB [NGC109000 -], 2050M Wide Track (WT) / Low Ground Pressure (LGP), Bulldozer (BD) Blade - Tier 4B (final) and Stage IIIB [NGC109000 -], 2050M Wide Track (WT) / Low Ground Pressure (LGP), Power Angle Tilt (PAT) Blade - Tier 4B (final) and Stage IIIB [NGC109000 -]

Engine - Remove

2050M

NA

⚠ WARNING

Heavy parts!
Support designated component(s) with adequate lifting equipment.
Failure to comply could result in death or serious injury.

W1024A

Prior operation:

Frame - Remove (39.100)

NOTICE: The engine weighs approximately **631 kg (1391 lb)**. Use appropriate lifting equipment to prevent personal injury or property damage.

NOTICE: The engine must be balanced as shown, or personal injury or property damage will occur.

1. Attach an appropriate lifting device to the engine lift points.
2. Support the front of the hydraulic pump stack with an appropriate lifting device or stand.
3. Remove the bolts and washers **(1)** from the right front engine-to-frame cradle mount and the left front engine-to-frame cradle mount.

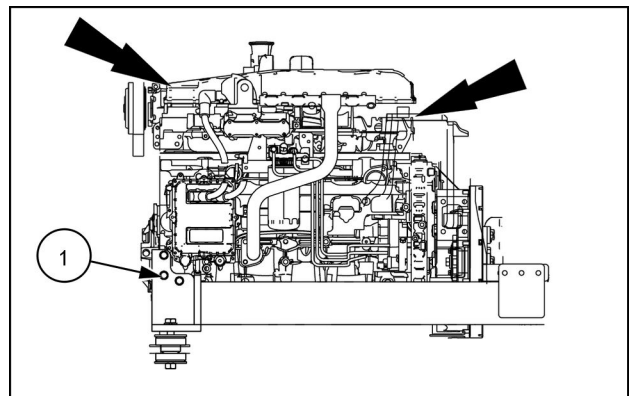

RAIL14DOZ0447AA 1

4. Remove the mounting bolts and washers **(1)** from the left side engine-to-frame cradle mounting bracket **(2)**. Remove the mounting bracket.

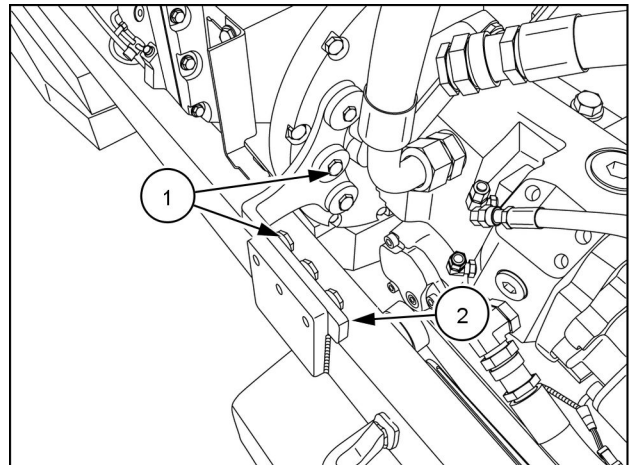

RAIL14DOZ0209AA 2

5. Remove the mounting bolts and washers (1) from the right side engine-to-frame cradle mounting bracket (2). Remove the bracket.

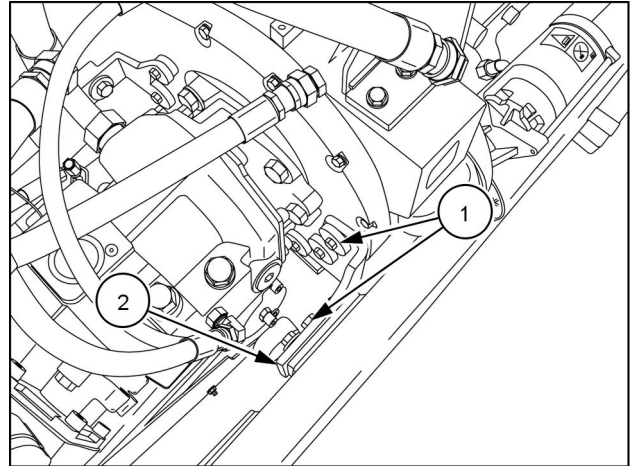

RAIL14DOZ0202AA 3

6. Remove the mounting bolts and washers (1) from the engine-to-pump stack adapter plate (2).
7. Slowly move the engine forward to separate it from the hydrostatic pump drive stack, and remove the engine from the frame cradle.

NOTE: Pull the engine straight forward horizontally by hand only from the hydraulic pump stack until the rubber coupler teeth clear the mating ring attached to the flywheel.

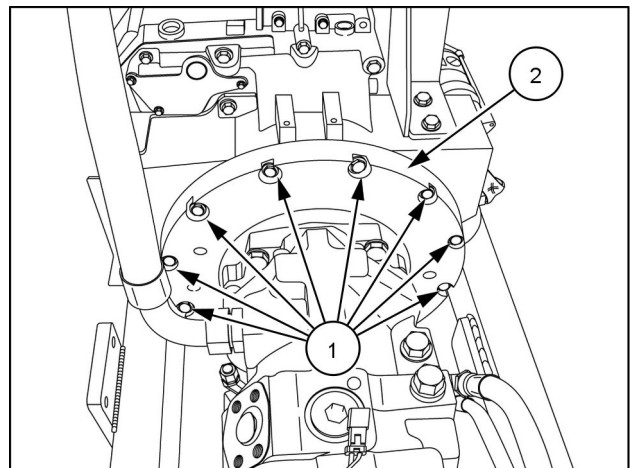

RAIL14DOZ0203AA 4

8. Remove the eight bolts (1) that secure the tandem pump flexible coupling mating ring to the engine flywheel and remove the mating ring.

NOTICE: Replace the flexible coupler when either the engine or hydrostatic pump stack are removed from the machine. The coupler is a flexible, rubber based component that could be damaged by excessive heat, excessive shock loading, unintended vibrations, or if soaked in oil. The coupler is in place to protect the integrity of the engine and pumps. Damage to coupler may not be visible.

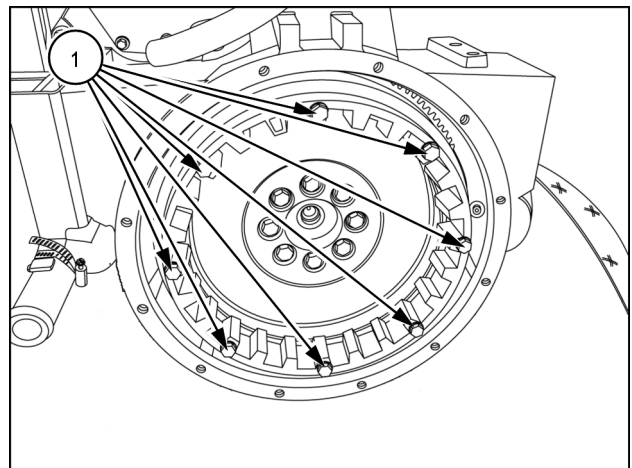

RAIL16DOZ0008AA 5

9. Remove the mounting bolts (1) and (2) from the left hydrostatic drive pump hub and spline (3).
10. Remove the flexible coupling drive gear (4) from the hydrostatic drive pump hub and spline.

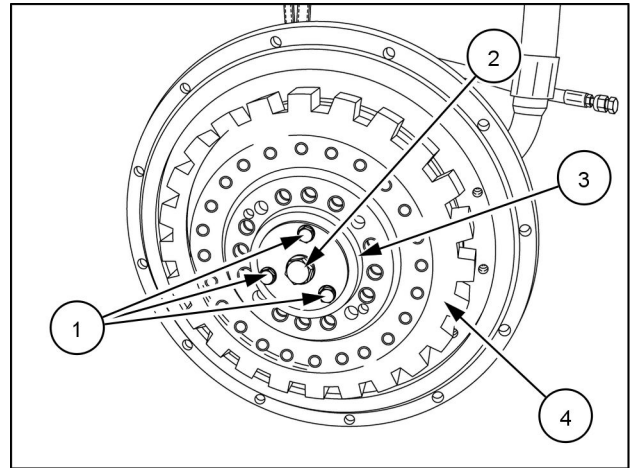

RAIL14DOZ0283AA 6

Next operation:
Engine - Install (10.001)

Engine - Install

2050M	NA
-------	----

⚠ WARNING

Heavy parts!
Support designated component(s) with adequate lifting equipment.
Failure to comply could result in death or serious injury.

W1024A

Prior operation:
Engine - Remove (10.001)

Prior operation:
 Clean threads of oil, dirt, and preservatives prior to assembly.

NOTICE: Replace the flexible coupler when either the engine or hydrostatic pump stack are removed from the machine. The coupler is a flexible, rubber based component that could be damaged by excessive heat, excessive shock loading, or unintended vibrations. The coupler is in place to protect the integrity of the engine and pumps. Damage to coupler may not be visible.

NOTE: Clean and inspect all hardware that is to be reused.

1. Apply **LOCTITE® 242®** to the eight bolts, and mount the new tandem pump flexible coupling mating ring (1) to the engine flywheel (2).

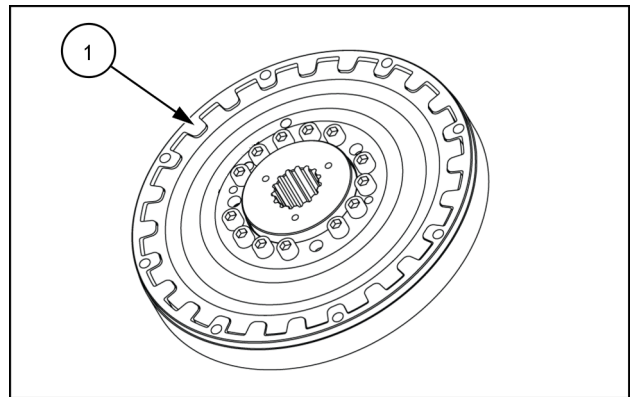

RAIL16DOZ0005AA 1

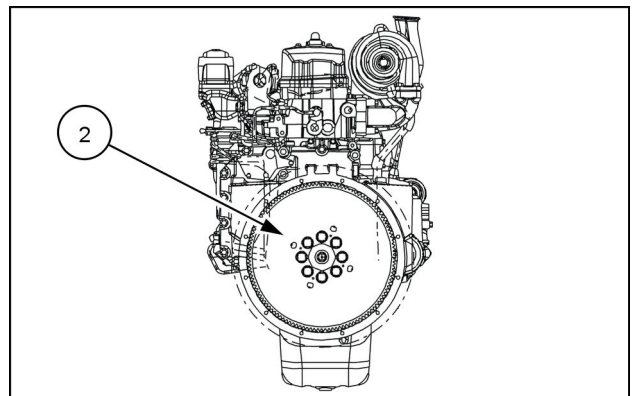

RAIL16DOZ0004AA 2

- Torque the bolts (1) to **41 – 50 N·m (30 – 37 lb ft)**

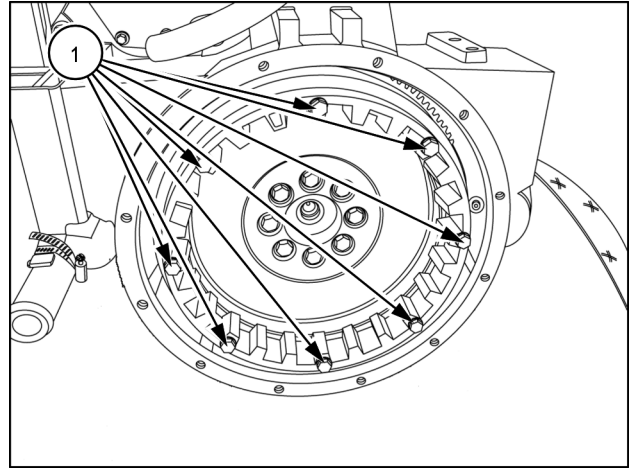

RAIL16DOZ0008AA 3

- Install the new coupler hub onto the left hydrostatic drive pump shaft (1).

NOTE: Use new hardware to secure the new coupler hub to the hydrostatic drive pump shaft.

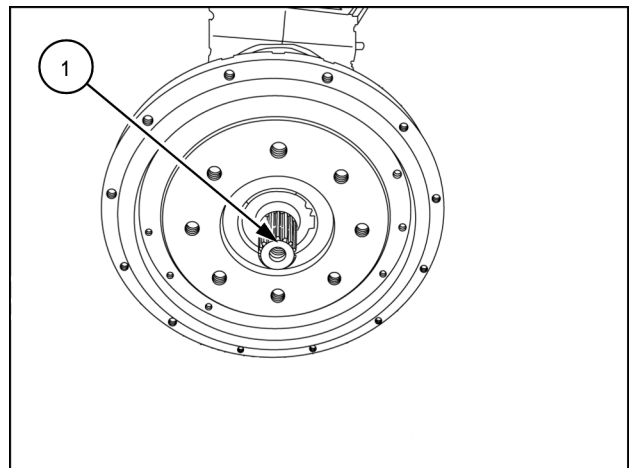

RAIL16DOZ0038AA 4

- Apply **LOCTITE® 242®** to all of the new bolts, then secure the new coupler hub to the left hydrostatic drive pump shaft with the new flexible coupler stop (1), center bolt and washer (2) and the three bolts and washers (3).
- Torque the outside bolts (3) to **27 – 35 N·m (20 – 26 lb ft)** and the center bolt (2) to **136 – 156 N·m (100 – 115 lb ft)**.

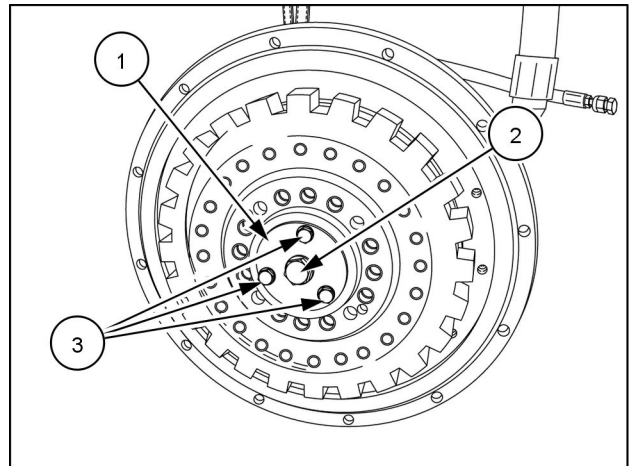

RAIL14DOZ0283AA 5

6. Slowly lower the engine into the frame cradle and connect the engine to the hydrostatic drive pump stack.

NOTE: Push the engine straight backward horizontally by hand only into the hydraulic pump stack until the rubber coupler teeth mesh with the mating ring attached to the flywheel.

7. Clean and apply **LOCTITE® 242®** to all of the bolts.
8. Install the twelve mounting bolts and washers (1) into the engine-to-pump stack adapter plate (2). Torque the bolts to **46 – 62 N·m (34 – 46 lb ft)**.

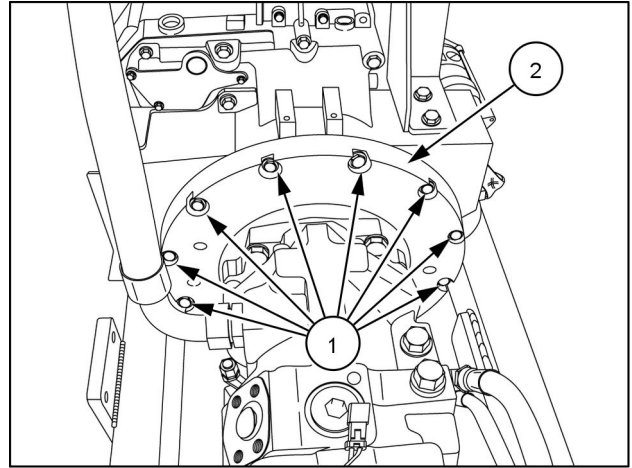

RAIL14DOZ0203AA 6

9. Use a level and verify that the engine mounting frame cradle is sitting on a level surface out of the machine.

NOTE: Before applying the torque to the mid engine-to-frame cradle mount bracket bolts and the front engine-to-mount frame cradle bolts to their final specification, make sure that the frame cradle is level.

10. Install the right side engine-to-frame cradle mounting bracket. Apply **LOCTITE® 242®** to the engine-to-frame cradle mounting bracket bolts. Torque the three bolts (1) **91 – 123 N·m (67 – 91 lb ft)** to the adapter plate, and the three bolts (2) **225 – 305 N·m (166 – 225 lb ft)** to the right side engine-to-frame cradle mounting bracket (3).

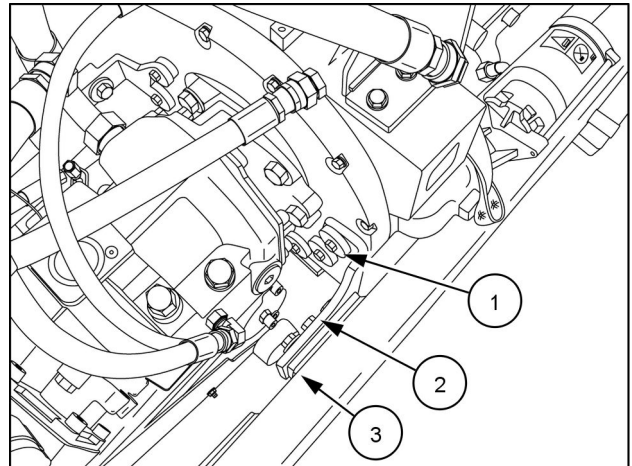

RAIL14DOZ0202AA 7

11. Install the left side engine-to-frame cradle mounting bracket. Apply **LOCTITE® 242®** to the engine-to-frame cradle mounting bracket bolts. Torque the three bolts (1) **91 – 123 N·m (67 – 91 lb ft)** to the adapter plate, and the three bolts (2) **225 – 305 N·m (166 – 225 lb ft)** to the left side engine-to-frame cradle mounting bracket (3).

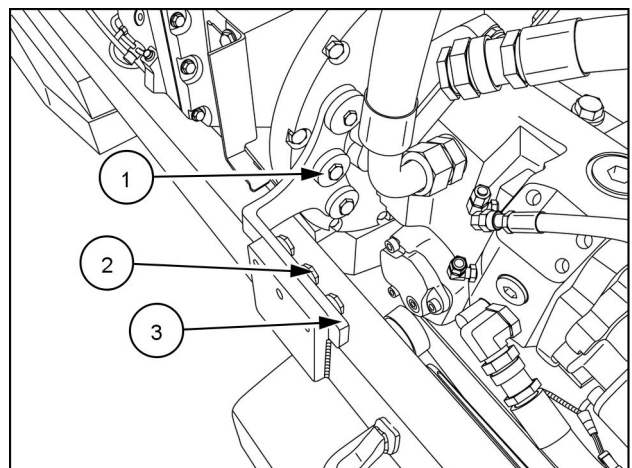

RAIL14DOZ0209AA 8

12. Install the bolts and washers **(1)** into the right front engine-to-frame cradle mount and the left front engine-to-frame cradle mount. Torque the bolts to **107 – 123 N·m (79 – 91 lb ft)**.

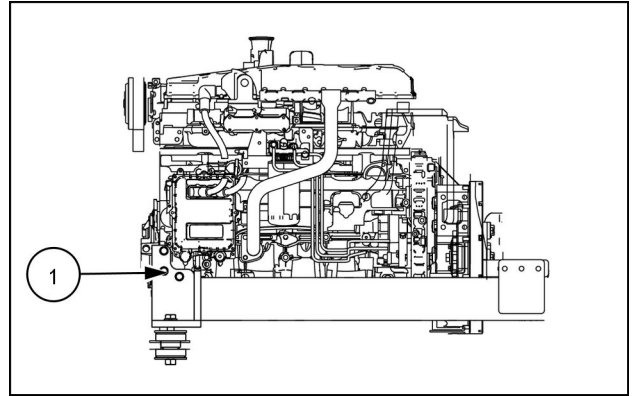

RAIL14DOZ0447AA 9

13. Remove the support from the hydraulic pump stack.
14. Remove the lifting device from the engine.

Next operation:
Frame - Install (39.100)

Fuel tank - Drain fluid - Fuel tank sediment

⚠ WARNING

Hot liquid under pressure!

Fuel in the high pressure fuel line is still under pressure immediately after you shut down the engine. Before performing any maintenance or inspection, wait for 2 minutes after engine shutdown to allow the pressure to drop.

Failure to comply could result in death or serious injury.

W0249A

⚠ WARNING

Chemical hazard!

When handling fuel, lubricants, and other service chemicals, follow the manufacturer's instructions. Wear Personal Protective Equipment (PPE) as instructed. Do not smoke or use open flame. Collect fluids in proper containers. Obey all local and environmental regulations when disposing of chemicals.

Failure to comply could result in death or serious injury.

W0371A

Drain condensation and sediment from the fuel tank when the hour meter registers 1000 hours of operation and every 1000 hours thereafter. Drain more frequently if conditions so require. The fuel tank drain is located on the left side of the machine.

Prior operation:

Keep all unauthorized personnel clear of the area. Park the machine on level ground, in neutral with the parking brake applied, and the attachment lowered to the ground. Make sure that all residual pressure is relieved from circuits before beginning maintenance.

1. Locate the fuel tank drain hose behind the bolt-on panel on the left side of the machine.

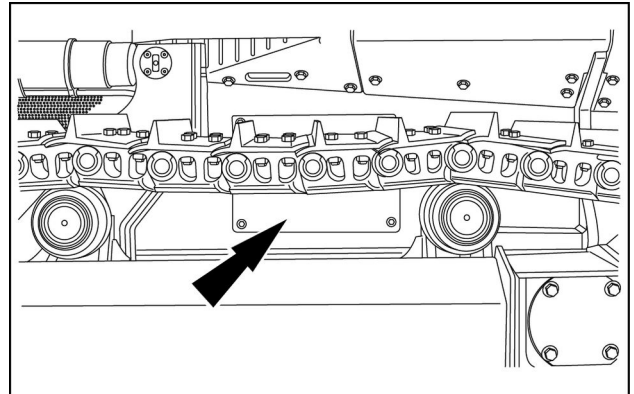

RAIL16DOZ0212AA 1

NOTE: On machines that are not equipped with the environmental drain option, connect a drain hose to the fuel tank drain valve. The drain valve is accessible through the right rear access panel or by removing the cab floor access panel and tilting back the operator's seat.

2. Remove the bolts and remove the panel.

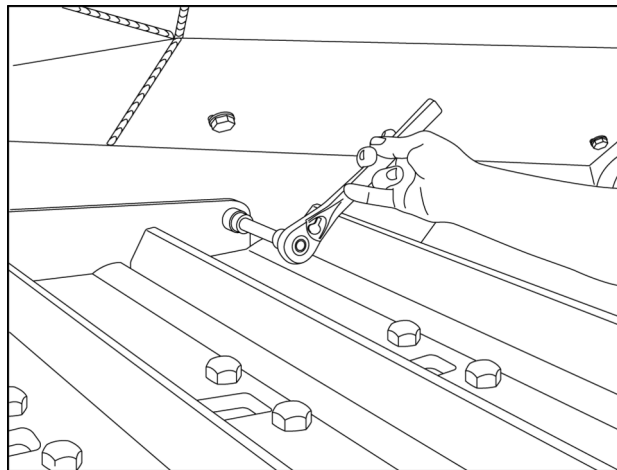

RAIL12DOZ0410AA 2

3. Pull the fuel tank drain hose forward, and remove the fitting.
4. Open the fuel shut off valve located on the fuel tank, and drain the water and sediment into a suitable container.

NOTE: The fuel tank shut off valve is accessible through the right rear access panel or by removing the cab floor access panel and tilting back the seat.

5. Dispose of the waste following local regulations.
6. Turn the shut off valve to the closed position after only clean fuel is discharged.
7. Replace the fitting on the hose.
8. Replace the hoses within the panel and wire tie, if necessary.
9. Check for leaks.
10. Replace the bolts and the cover panel.

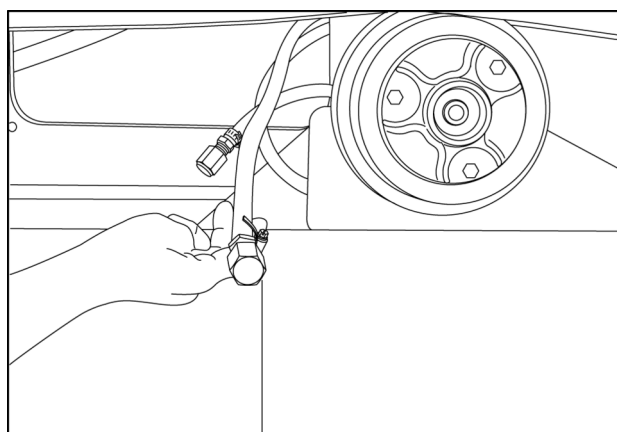

RAIL12DOZ0412AA 3

Fuel tank - Remove

2050M

NA

1. Remove the cab from the machine. See **Cab - Remove (90.150)**.
2. Remove four bolts and washers **(1)** and remove the fuel / Diesel Exhaust Fluid (DEF) drain hose access panel **(2)** from the left side of the machine.

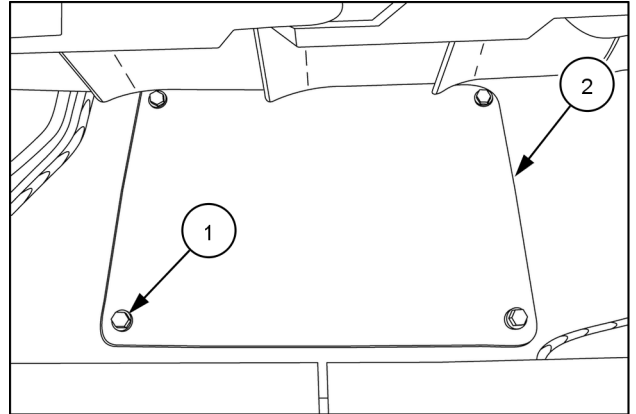

RAIL14DOZ0141AA 1

3. Remove the fuel tank drain hose cap **(1)** from the fuel tank drain hose **(2)**.

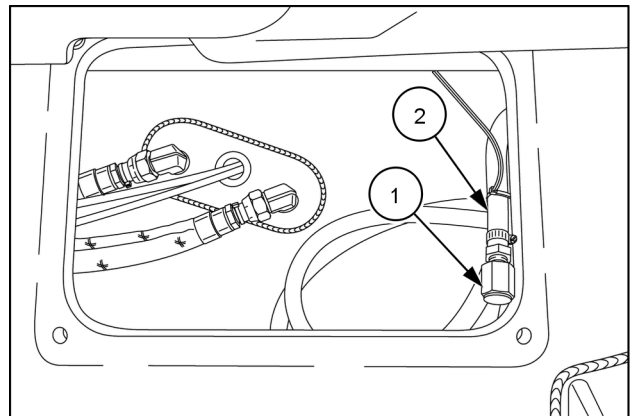

RAIL14DOZ0142AA 2

4. Open the fuel tank drain valve and drain the fuel into a suitable container for storage. Close the drain valve when complete.

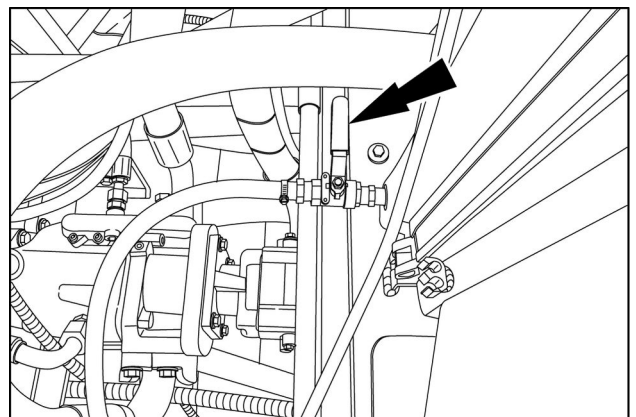

RAIL14DOZ0144AA 3

5. Loosen the drain hose clamp (1) and remove the drain hose (2) from the drain valve (3).

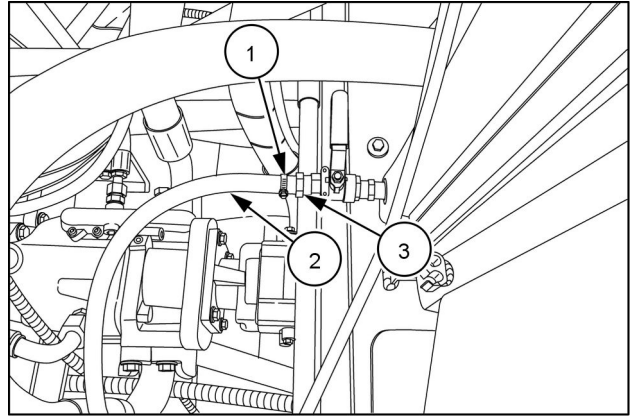

RAIL14DOZ0144AA 4

6. Install the fuel tank drain hose cap (1) to the fuel tank drain hose (2).

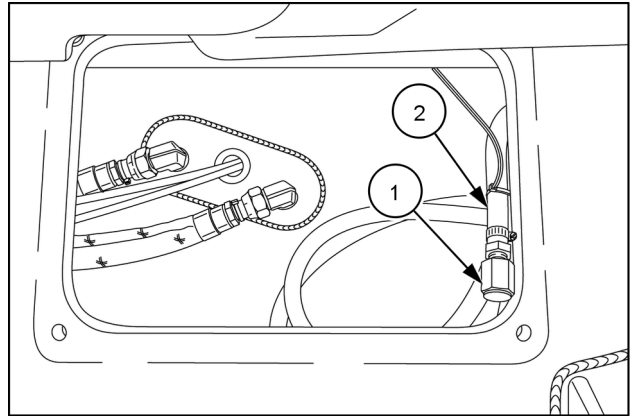

RAIL14DOZ0142AA 5

7. Tag and disconnect the fuel supply (1) and the fuel return (2) lines from the top of the fuel tank. Close all openings to prevent fuel loss or contamination.

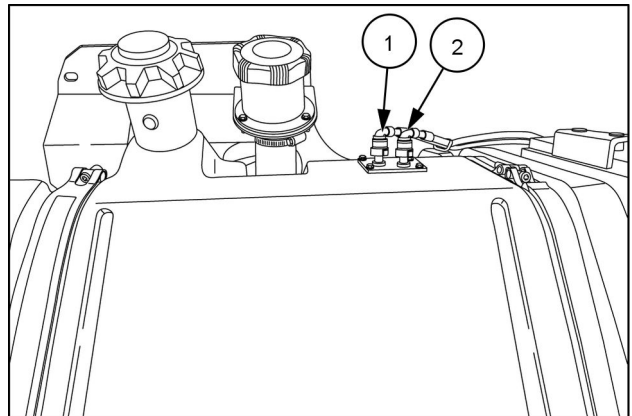

RAIL14DOZ0143AA 6

8. Remove the fuel supply (1) and the fuel return (2) hoses from the four retaining clips (3) at the top rear of the fuel tank.

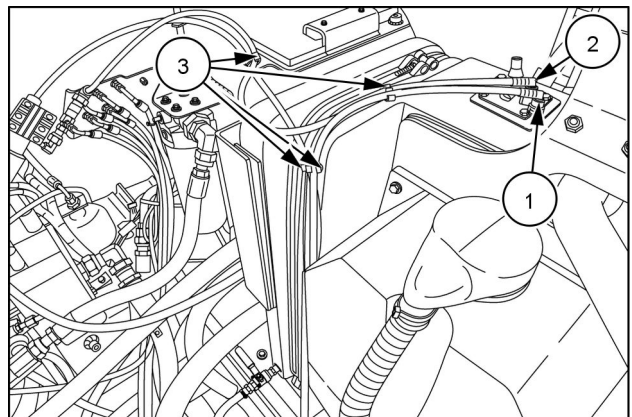

RAIL14DOZ0145AA 7

9. Remove the two fuel tank strap retaining bolts (1) and one locknut (2). Remove the fuel tank retaining straps (3) from the machine.

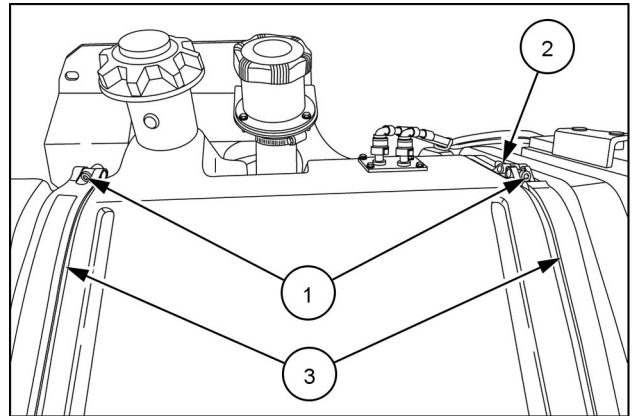

RAIL14DOZ0143AA 8

10. Loosen the DEF tank fill hose clamp (1).

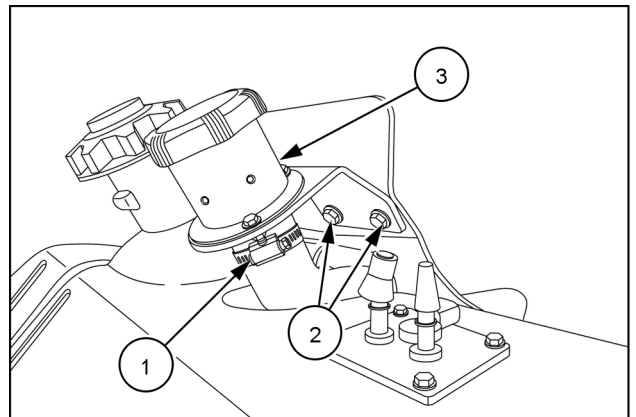

RAIL14DOZ0146AA 9

11. Remove the two DEF filler neck bolts and washers (2) and remove the DEF filler neck (3) from the machine. Close all openings.

NOTE: The DEF tank does not need to be removed from the machine, however, it must be moved forward to gain clearance for the fuel tank removal.

12. Remove the five DEF tank mounting bolts and washers (1). Slide the DEF tank (2) toward the front of machine.

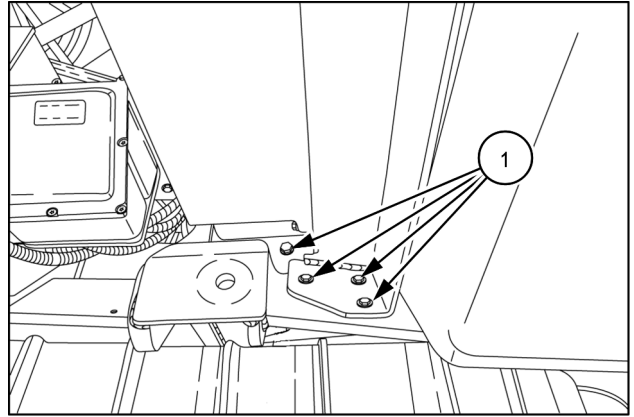

RAIL14DOZ0148AA 10

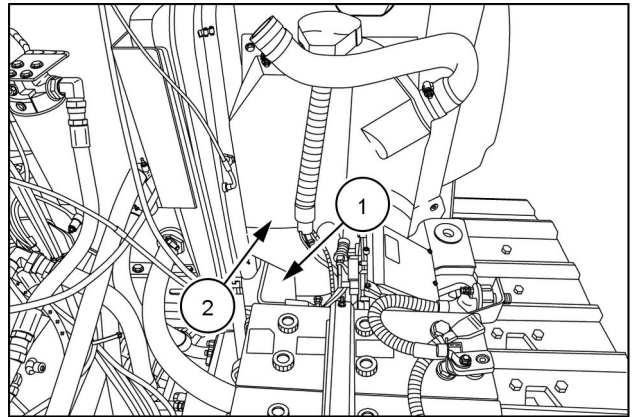

RAIL14DOZ0147AA 11

NOTICE: The fuel tank weighs approximately **31.8 kg (70 lb)** when empty. Use appropriate lifting equipment to prevent personal injury or property damage.

13. With the aid of a helper, remove the fuel tank from the machine.
14. Repair or replace components as necessary.

Fuel tank - Install

2050M

NA

NOTICE: The fuel tank weighs approximately **31.8 kg (70 lb)** when empty. Use appropriate lifting equipment to prevent personal injury or property damage.

1. With the aid of a helper, install the fuel tank to the machine.
2. Slide the DEF tank (1) rearward into position. Install five Diesel Exhaust Fluid (DEF) tank mounting bolts and washers (2). Tighten the bolts.

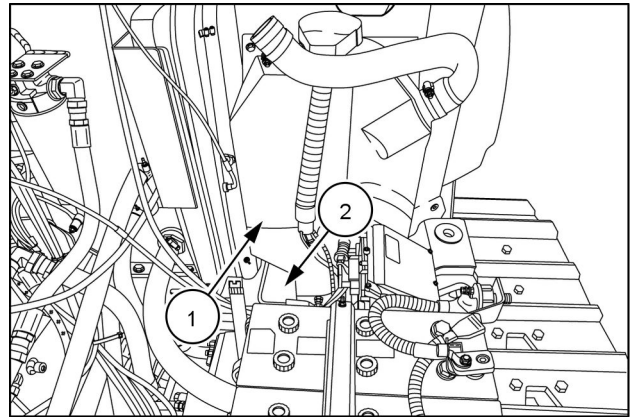

RAIL14DOZ0147AA 1

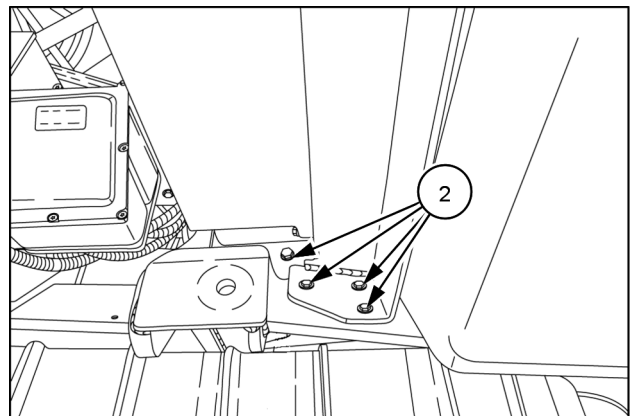

RAIL14DOZ0148AA 2

3. Install the DEF filler neck (1) to the machine with two mounting bolts and washers (2). Tighten the bolts.

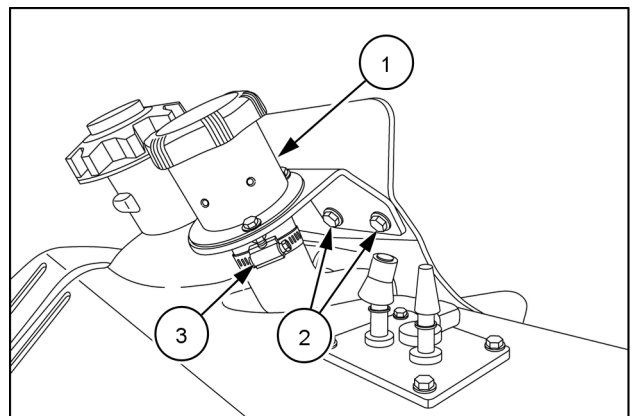

RAIL14DOZ0146AA 3

4. Tighten the DEF fill hose clamp (3).

5. Install the fuel tank retaining straps (1) to the machine and secure with two retaining bolts (2) and one locknut (3). Tighten the bolts.

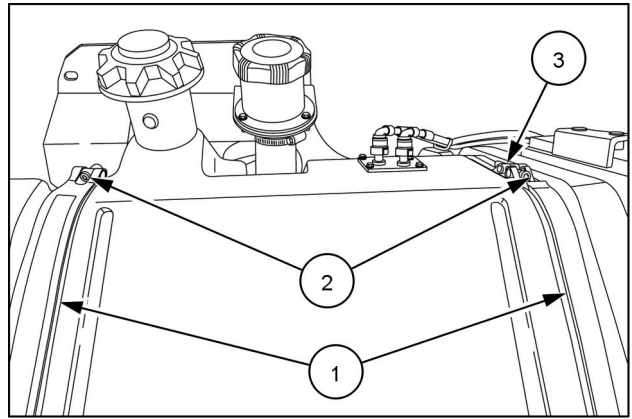

RAIL14DOZ0143AA 4

6. Install the fuel supply (1) and the fuel return (2) hoses into the four retaining clips (3).

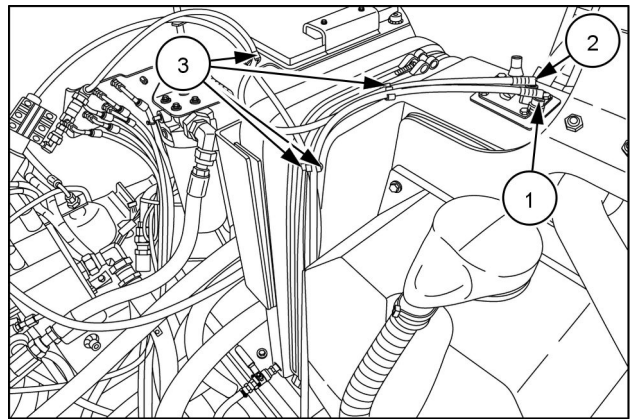

RAIL14DOZ0145AA 5

7. Connect the fuel drain hose (1) to the fuel drain valve (2) and tighten the clamp (3).

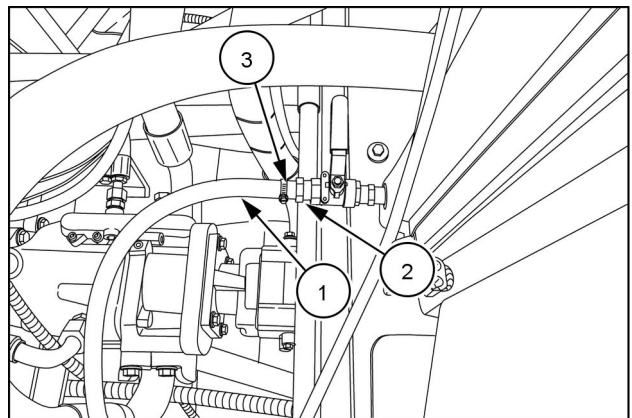

RAIL14DOZ0144AA 6

8. Connect the fuel supply (1) and the fuel return (2) lines to the top of the fuel tank.

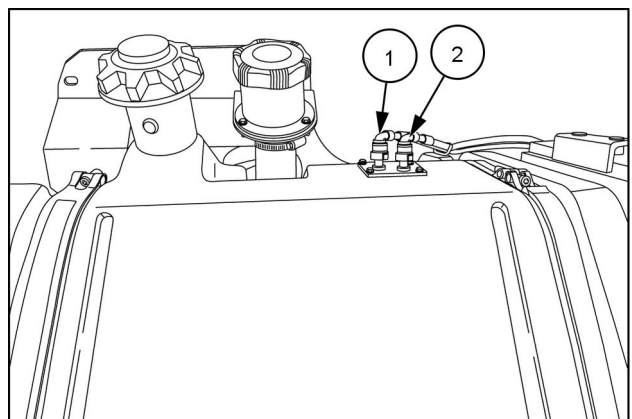

RAIL14DOZ0143AA 7

9. Install the fuel/DEF drain hose access panel **(1)** to the left side of the machine and secure with four bolts and washers **(2)**. Tighten the bolts.

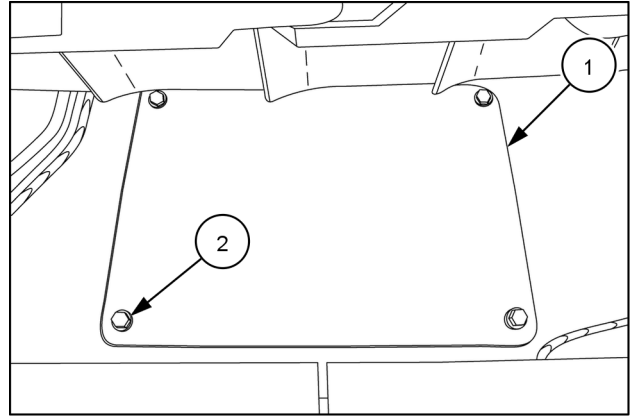

RAIL14DOZ0141AA 8

10. Fill the fuel tank.
11. Install the cab to the machine. See **Cab - Install (90.150)** .

Fuel filters - Service instruction - Removing air from the fuel system

2050M

NA

1. Remove air from the fuel system after changing the fuel filter. Removing air from the fuel system may also be necessary if the machine runs out of fuel, if the fuel system has been serviced, or if the machine has been in storage.
2. Make certain that the fuel tank shutoff is in the ON position.
3. Loosen the air bleed screw one or two turns.
4. Operate the hand primer until no air bubbles flow from around the air bleed screw.
5. Tighten the air bleed screw.
6. Start the engine and check for leaks.

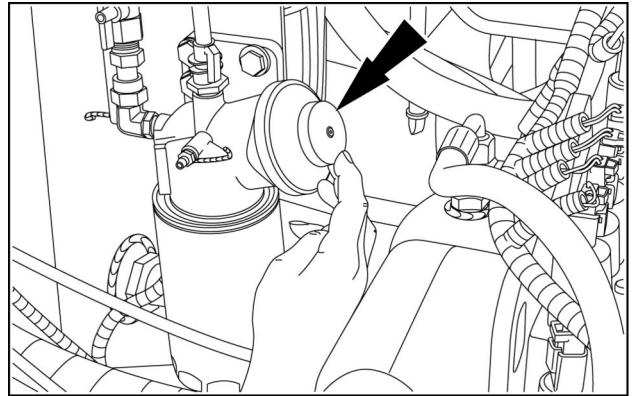

RAPH12DOZ0056AA 1

Fuel filters - Replace

⚠ WARNING

Fire hazard!

When handling diesel fuel, observe the following precautions:

1. Do not smoke.
2. Never fill the tank when the engine is running.
3. Wipe up spilled fuel immediately.

Failure to comply could result in death or serious injury.

W0099A

Prior operation:

Keep all unauthorized personnel clear of the area. Park the machine on level ground, in neutral with the parking brake applied, and the attachment lowered to the ground. Make sure that all residual pressure is relieved from circuits before beginning maintenance.

1. Locate the fuel prefilter in the right rear access compartment. Close the fuel shut off valve to prevent fuel leakage.
2. Clean the fuel prefilter head, the outside of the fuel prefilter, and remove any dirt and debris around the area that might contaminate the system.
3. Disconnect the wire harness (1).

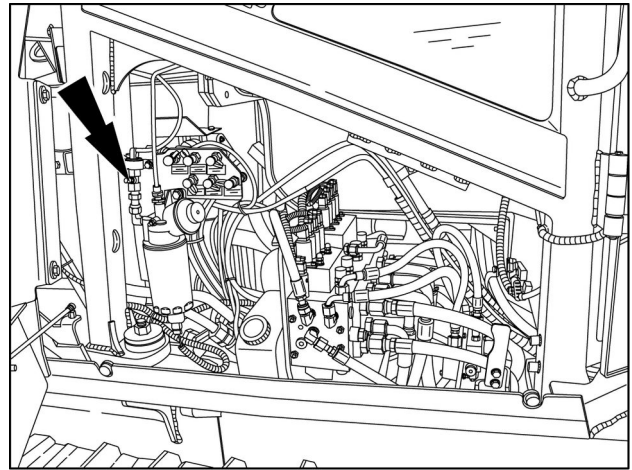

RAIL13DOZ1686AA 1

4. Turn the fuel prefilter (2) counterclockwise and remove. Capture any fuel remaining in the lines or the fuel filter, and discard properly.
5. Apply a thin layer of clean oil to the gasket on the new fuel prefilter (2).
6. Install the fuel prefilter. Use your hands to tighten the fuel prefilter 1/2 to 3/4 turn after the prefilter makes contact with the filter head.
7. Reconnect the wire harness (1).
8. Check for leaks.

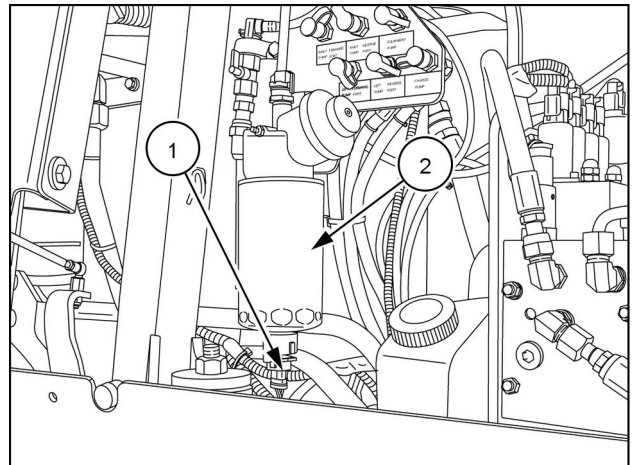

RAIL13DOZ1699AA 2

NOTICE: Never use a filter wrench to tighten a new fuel filter on install.



Suggest:

If the above button click is invalid.

Please download this document

first, and then click the above link

to download the complete manual.

Thank you so much for reading

9. Locate the fuel filter in the front left engine compartment.
10. Clean the fuel filter head, the outside of the fuel filter, and remove any dirt and debris around the area that might contaminate the system.
11. Turn the fuel filter counterclockwise and remove. Capture any fuel remaining in the lines or the fuel filter, and discard properly.
12. Apply a thin layer of clean oil to the gasket on the new fuel filter.
13. Install the filter. Use your hands to tighten the fuel filter 1/2 to 3/4 turn after the fuel filter makes contact with the filter head.
14. Check for leaks.

NOTICE: Never use a filter wrench to tighten a new fuel filter on install.

Removing air from the fuel system

1. Remove air from the fuel system after changing the fuel filter. Removing air from the fuel system may also be necessary if the machine runs out of fuel, if the fuel system has been serviced, or if the machine has been in storage.
2. Make certain that the fuel tank shutoff is in the ON position.
3. Loosen the air bleed screw one or two turns.
4. Operate the hand primer until no air bubbles flow from around the air bleed screw.
5. Tighten the air bleed screw.
6. Start the engine, and check for leaks.

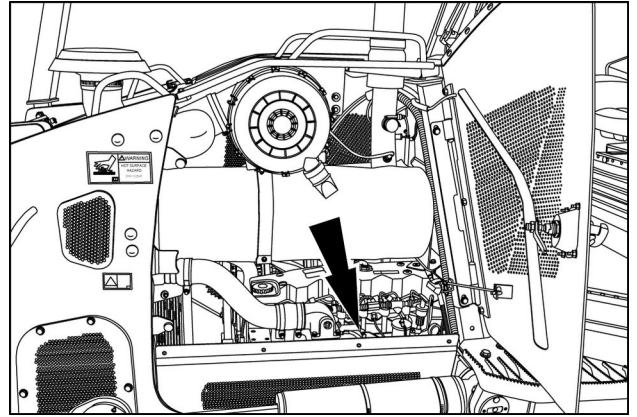

RAIL16DOZ0370AA 3

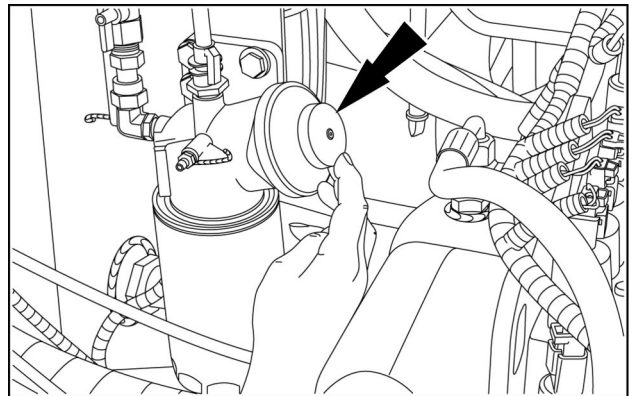

RAPH12DOZ0056AA 4

<https://www.ebooklibonline.com>

Hello dear friend!

Thank you very much for reading.

Enter the link into your browser.

The full manual is available for immediate download.

<https://www.ebooklibonline.com>