



SERVICE MANUAL

1150L XLT PAT

Link Product / Engine

Product	Market Product	Engine
1150L XLT PAT	Latin America	F4HE9684K*J100

Contents

INTRODUCTION

Engine.....	10
[10.001] Engine and crankcase	10.1
[10.400] Engine cooling system	10.2
[10.310] Aftercooler.....	10.3
[10.304] Engine lubrication system.....	10.4
Rear axle system.....	27
[27.120] Planetary and final drives	27.1
[27.126] Spur gear and final drives.....	27.2
Hydrostatic drive.....	29
[29.100] Transmission and steering hydrostatic control	29.1
[29.202] Hydrostatic transmission	29.2
Brakes and controls	33
[33.202] Hydraulic service brakes	33.1
Hydraulic systems.....	35
[35.000] Hydraulic systems.....	35.1
[35.104] Fixed displacement pump.....	35.2
[35.310] Distributor and lines	35.3
[35.350] Safety and main relief valves	35.4
[35.741] Dozer blade cylinders	35.5
[35.742] Ripper hydraulic system.....	35.6
Tracks and track suspension.....	48
[48.130] Track frame and driving wheels.....	48.1
[48.110] Front suspension	48.2
[48.100] Tracks	48.3
[48.134] Track tension units	48.4

<https://www.ebooklibonline.com>

Hello dear friend!

Thank you very much for reading.

Enter the link into your browser.

The full manual is available for immediate download.

<https://www.ebooklibonline.com>

[48.138] Track rollers	48.5
Cab climate control	50
[50.100] Heating	50.1
[50.200] Air conditioning	50.2
Electrical systems	55
[55.013] Engine oil system	55.1
[55.000] Electrical system	55.2
[55.100] Harnesses and connectors	55.3
[55.525] Cab engine controls	55.4
[55.015] Engine control system	55.5
[55.201] Engine starting system	55.6
[55.301] Alternator	55.7
[55.302] Battery	55.8
[55.202] Cold start aid	55.9
[55.010] Fuel injection system	55.10
[55.012] Engine cooling system	55.11
[55.019] Hydrostatic drive control system	55.12
[55.050] Heating, Ventilation, and Air-Conditioning (HVAC) control system	55.13
[55.408] Warning indicators, alarms, and instruments	55.14
[55.101] Chassis harness	55.15
[55.014] Engine intake and exhaust system	55.16
[55.DTC] FAULT CODES	55.17
Dozer blade and arm	86
[86.110] Dozer blade	86.1
Tools	89
[89.128] Ripper assembly	89.1
Platform, cab, bodywork, and decals	90
[90.150] Cab	90.1

[90.114] Operator protections 90.2
[90.124] Pneumatically-adjusted operator seat..... 90.3



INTRODUCTION

Foreword - Important notice regarding equipment servicing

All repair and maintenance work listed in this manual must be carried out only by qualified dealership personnel, strictly complying with the instructions given, and using, whenever possible, the special tools.

Anyone who performs repair and maintenance operations without complying with the procedures provided herein shall be responsible for any subsequent damages.

The manufacturer and all the organizations of its distribution chain, including - without limitation - national, regional, or local dealers, reject any responsibility for damages caused by parts and/or components not approved by the manufacturer, including those used for the servicing or repair of the product manufactured or marketed by the manufacturer. In any case, no warranty is given or attributed on the product manufactured or marketed by the manufacturer in case of damages caused by parts and/or components not approved by the manufacturer.

The manufacturer reserves the right to make improvements in design and changes in specifications at any time without notice and without incurring any obligation to install them on units previously sold. Specifications, descriptions, and illustrative material herein are as accurate as known at time of publication but are subject to change without notice.

In case of questions, refer to your CASE CONSTRUCTION Sales and Service Networks.

Foreword - How to use and navigate through this manual

This manual has been produced by a new technical information system. This new system is designed to deliver technical information electronically through web delivery (eTIM), DVD, and paper manuals. A coding system called SAP has been developed to link the technical information to other Product Support functions, e.g., Warranty.

Technical information is written to support the maintenance and service of the functions or systems on a customer's machine. When a customer has a concern on their machine it is usually because a function or system on their machine is not working at all, is not working efficiently, or is not responding correctly to their commands. When you refer to the technical information in this manual to resolve that customer's concern, you will find all the information classified using the SAP coding, according to the functions or systems on that machine. Once you have located the technical information for that function or system, you will then find all the mechanical, electrical or hydraulic devices, components, assemblies, and sub assemblies for that function or system. You will also find all the types of information that have been written for that function or system: the technical data (specifications), the functional data (how it works), the diagnostic data (fault codes and troubleshooting), and the service data (remove, install adjust, etc.).

By integrating SAP coding into technical information, you will be able to search and retrieve just the right piece of technical information you need to resolve that customer's concern on his machine. This is made possible by attaching 3 categories to each piece of technical information during the authoring process.

The first category is the Location, the second category is the Information Type and the third category is the Product:

- LOCATION - the component or function on the machine, that the piece of technical information is going to describe (e.g., Fuel tank).
- INFORMATION TYPE - the piece of technical information that has been written for a particular component or function on the machine (e.g., Capacity would be a type of Technical Data describing the amount of fuel held by the fuel tank).
- PRODUCT - the model for which the piece of technical information is written.

Every piece of technical information will have those three categories attached to it. You will be able to use any combination of those categories to find the right piece of technical information you need to resolve that customer's concern on their machine.

That information could be:

- the procedure for how to remove the cylinder head
- a table of specifications for a hydraulic pump
- a fault code
- a troubleshooting table
- a special tool

Manual content

This manual is divided into Sections. Each Section is then divided into Chapters. Contents pages are included at the beginning of the manual, then inside every Section and inside every Chapter. An alphabetical Index is included at the end of each Chapter. Page number references are included for every piece of technical information listed in the Chapter Contents or Chapter Index.

Each Chapter is divided into four Information types:

- Technical Data (specifications) for all the mechanical, electrical or hydraulic devices, components, assemblies or sub-assemblies.
- Functional Data (how it works) for all the mechanical, electrical or hydraulic devices, components, assemblies or sub-assemblies.
- Diagnostic Data (fault codes, electrical and hydraulic troubleshooting) for all the mechanical, electrical or hydraulic devices, components, assemblies or sub-assemblies.
- Service Data (remove disassemble, assemble, install) for all the mechanical, electrical or hydraulic devices, components, assemblies or sub-assemblies.

Sections

Sections are grouped according to the main functions or a systems on the machine. Each Section is identified by a number (00, 35, 55, etc.). The Sections included in the manual will depend on the type and function of the machine that the manual is written for. Each Section has a Contents page listed in alphabetic/numeric order. This table illustrates which Sections could be included in a manual for a particular product.

SECTION	PRODUCT					
	Tractors					
	Vehicles with working arms: backhoes, excavators, skid steers,					
	Combines, forage harvesters, balers,					
	Seeding, planting, floating, spraying equipment,					
Mounted equipment and tools,						
00 - Maintenance	X	X	X	X	X	
05 - Machine completion and equipment	X	X	X	X	X	
10 - Engine	X	X	X	X		
14 - Main gearbox and drive	X	X	X	X		
18 - Clutch	X	X	X			
21 - Transmission	X	X	X	X		
23 - Four wheel drive (4WD) system	X	X	X	X		
25 - Front axle system	X	X	X	X		
27 - Rear axle system	X	X	X	X		
29 - Hydrostatic drive	X	X	X	X		
31 - Power Take-Off (PTO)	X		X			
33 - Brakes and controls	X	X	X	X		
35 - Hydraulic systems	X	X	X	X		
36 - Pneumatic system	X	X	X	X		
37 - Hitches, drawbars and implement couplings	X		X	X		
39 - Frames and ballasting	X	X	X	X	X	
41 - Steering	X	X	X	X		
44 - Wheels	X	X	X	X		
46 - Steering clutches						
48 - Tracks and track suspension	X	X	X			
50 - Cab climate control	X	X	X	X		
55 - Electrical systems	X	X	X	X	X	
56 - Grape harvester shaking						
58 - Attachments/headers			X			
60 - Product feeding			X			

INTRODUCTION

61 - Metering system				X	
62 - Pressing - Bale formation			X		
63 - Chemical applicators				X	
64 - Chopping			X		
66 - Threshing			X		
68 - Tying/Wrapping/Twisting			X		
69 - Bale wagons					
70 - Ejection			X		
71 - Lubrication system	X	X	X	X	X
72 - Separation			X		
73 - Residue handling			X		
74 - Cleaning			X		
75 - Soil preparation/Finishing					
76 - Secondary cleaning / Destemmer					
77 - Seeding				X	
78 - Spraying				X	
79 - Planting				X	
80 - Crop storage / Unloading			X		
82 - Front loader and bucket	X	X			
83 - Telescopic single arm	X	X			
84 - Booms, dippers and buckets	X	X			
86 - Dozer blade and arm	X	X			
88 - Accessories	X	X	X	X	X
89 - Tools	X	X	X	X	X
90 - Platform, cab, bodywork and decals	X	X	X	X	



SERVICE MANUAL

Engine

1150L XLT PAT

Engine - Remove

1. Remove radiator.

NOTE: If the machine is equipped with a brush-type shield, continue to item 2. Otherwise, go to item 3.

2. Install appropriate lifting equipment on the brush-type shield. Remove the two lower bolts and the jam nuts. Remove the two upper bolts and the fixing washers of the brush-type shield. Remove the brush-type shield.
3. Remove the side doors of the engine compartment.
4. Loosen the air filter hose clamps. Remove the hose. Disconnect the electrical connectors from the air restriction indicator.

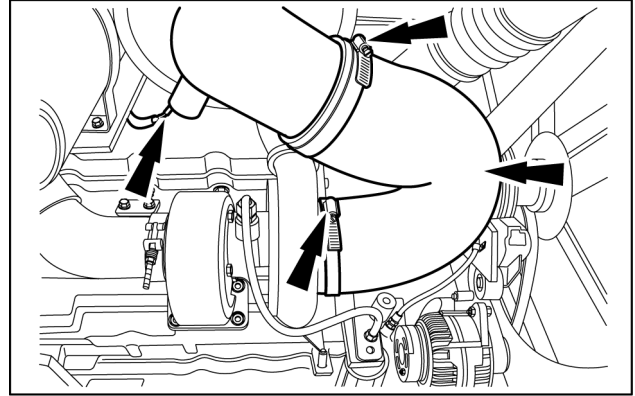

LAIL11CD1104A0A 1

5. Loosen the inlet hose clamp of the intake air cooler.

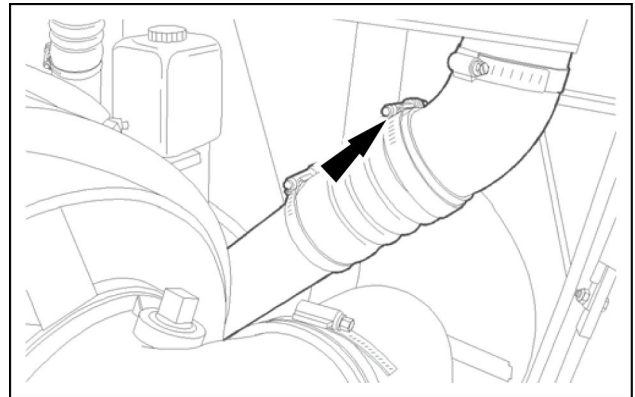

LAIL11CD1682A0A 2

6. Loosen the hose clamp from the intake air cooler located on the turbocharger outlet. Remove the intake air cooler line.

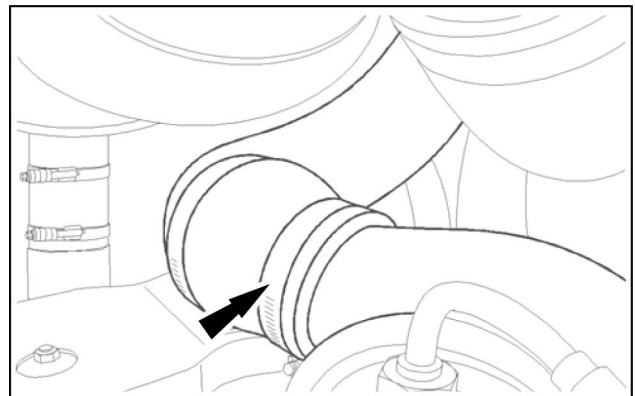

LAIL11CD1683A0A 3

7. Loosen the engine inlet hose clamp.

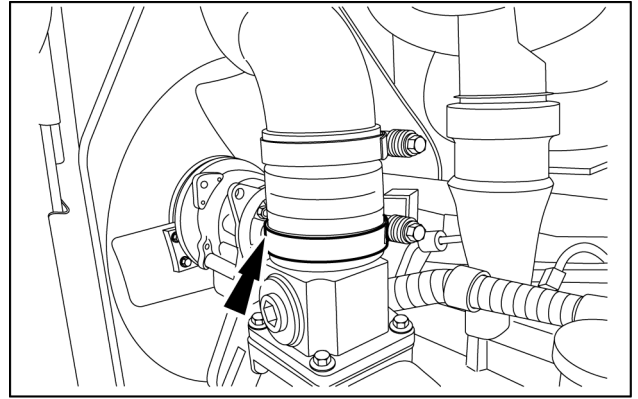

LAIL11CD1105A0A 4

8. Loosen the outlet hose clamp of the intake air cooler. Remove the intake air cooler line.

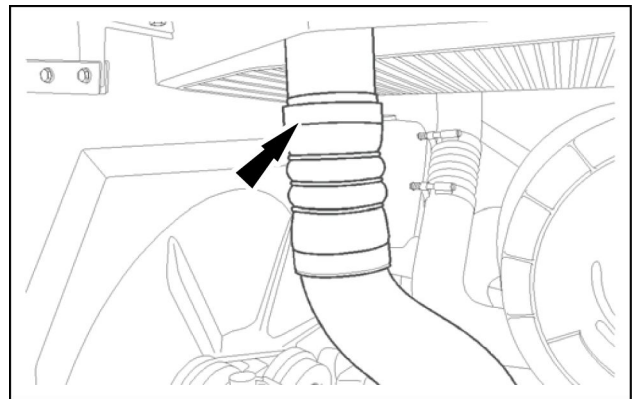

LAIL11CD1684A0A 5

9. Install lifting equipment on the hood.
10. Remove the two nuts and the washers (2) from the rear of the engine hood.

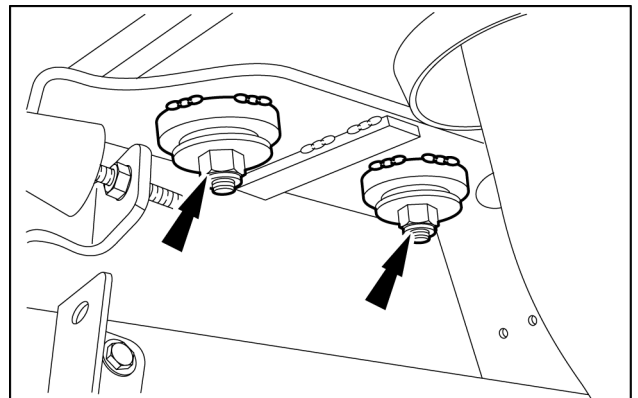

LAIL11CD1106A0A 6

11. Remove the four bolts (1), the hood mounting bolts (2), and the strap from the radiator (3).

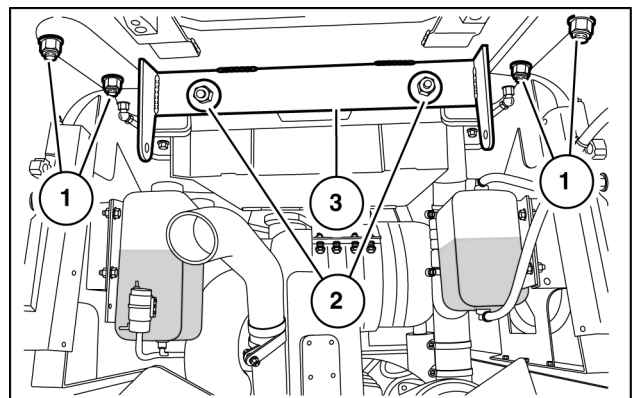

LAIL11CD1107A0A 7

12. Remove the hood, the air filter, and the intake air cooler from the machine.

13. If the machine is equipped with a heater, loosen the clamps. Disconnect the heater hoses. Cap the end of the hoses to prevent the spillage of coolant.
14. Disconnect the wires from the alternator.

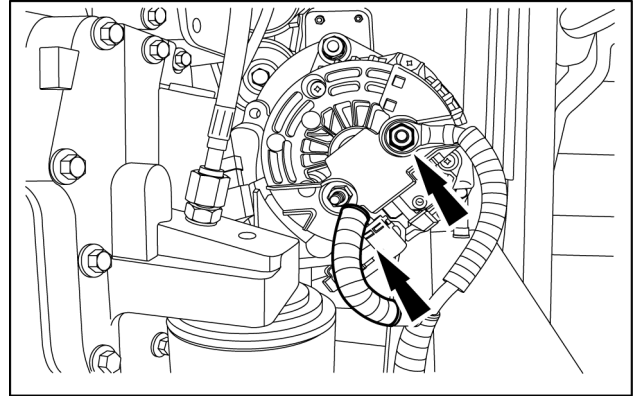

LAIL11CD1108A0A 8

15. Disconnect the battery cable and the wires of the starter motor wiring harness.

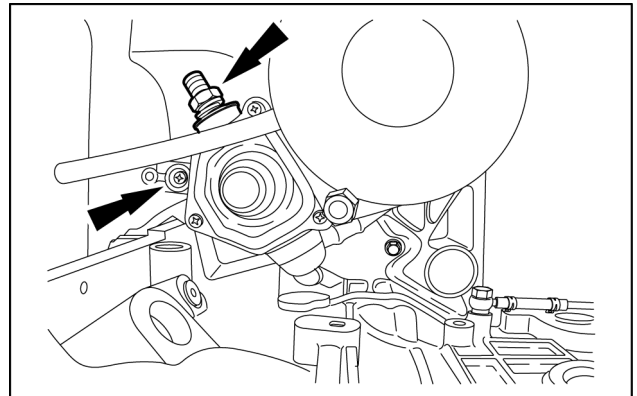

LAIL11CD1672A0A 9

16. Discharge the air-conditioning system. See **Air conditioning - Charging (50.200)**. Disconnect the clutch electrical connector and the compressor hoses. Plug the ends of the hoses and the fittings.

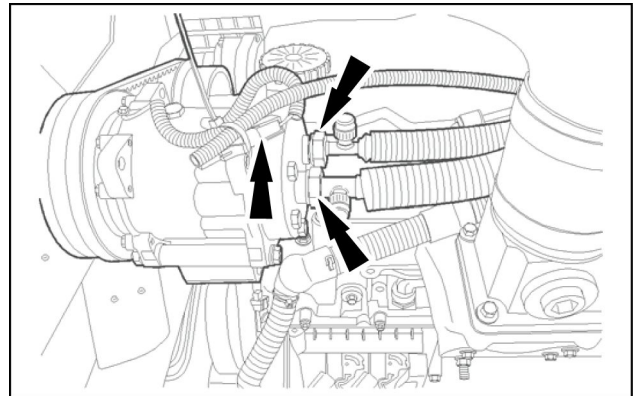

LAIL11CD1685A0A 10

17. Disconnect the electrical connector of the Engine Control Unit.

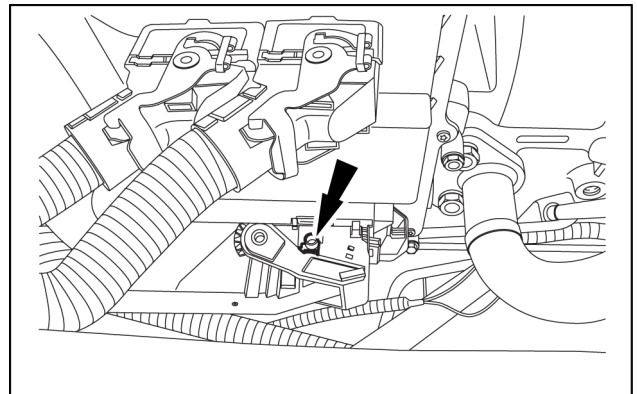

LAIL11CD1109A0A 11

18. Close the fuel valve (1). Disconnect the fuel line from the valve (2) and from the engine (3).

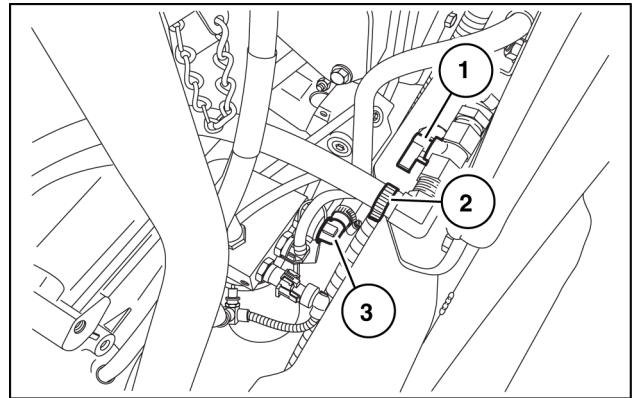

LAIL11CD1110A0A 12

19. Disconnect the ground cable from the extension housing.

NOTE: Tilt the cab or ROPS canopy. See **Roll Over Protective Structure (ROPS) frame - Tilt (90.114)**.

20. The wiring harnesses and the hoses of the heater (if equipped) can be pulled into the hydrostatic compartment and moved away.
21. Install lifting equipment on the engine.
22. Remove the mounting bolts from the rear of the engine.

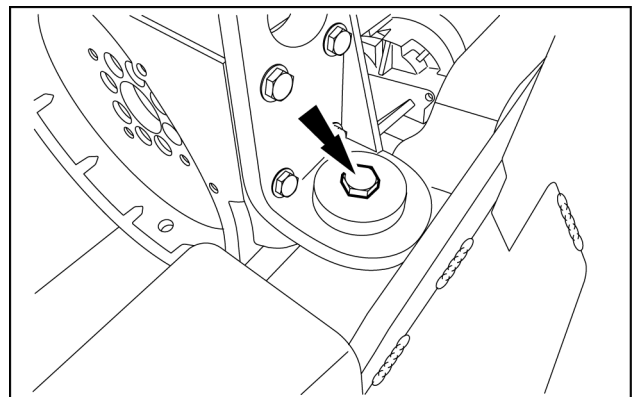

LAIL11CD1111A0A 13

23. Remove the mounting bolt from the front of the engine.

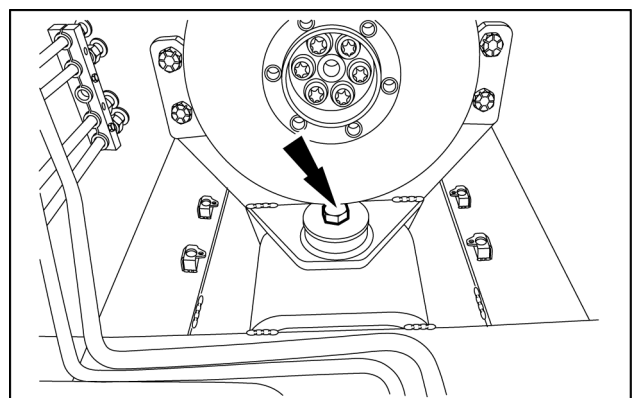

LAIL11CD1112A0A 14

24. Lift the engine slightly. Move the engine forward. Slide the drive shaft to disconnect the drive shaft from the hydro pumps until the bulkhead engine is freed.
25. Remove the engine from the machine.

Engine - Disassemble

1150L

LA

Reconditioning the engine on the workbench

1. Remove the drain plug from the crankcase to drain the engine oil.
2. Use the supports to secure the engine to the trestle as follows (work from the left-hand side of the engine).
 - Use a suitable tool to remove the fuel filter (5) from its bracket (1).
 - Disconnect the low pressure lines (2), (3), and (4) from the fuel filter bracket (1).
 - Remove the fuel filter bracket (1) from the engine block.

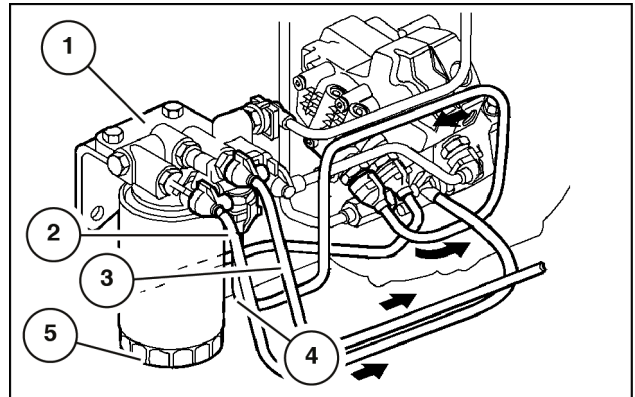

LAIL11CD1407A0A 1

3.

NOTICE: Push the clamp (1), as shown in Fig. 2, to disconnect the low pressure fuel lines (2), (3), and (4) from the corresponding fittings. After you disconnect the lines, put the clamp (1) back in the position shown in Fig. 2 to prevent the deformation of the clamp.

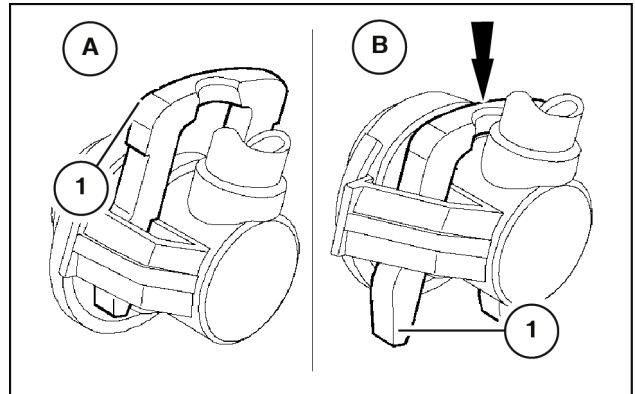

LAIL11CD1408A0A 2

4. Disconnect the fuel line (1) from the "common rail" and from the high pressure pump (5). Remove the mounting bolts (2) to remove the fuel line.

NOTICE: When you loosen the fitting (3) of the fuel line (1), use an appropriate wrench so that the fitting (4) of the high pressure pump (5) does not turn.

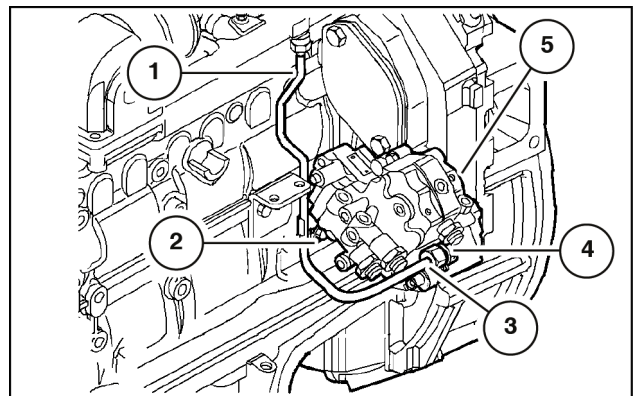

LAIL11CD1409A0A 3

5. From the Right-hand Side:
 Remove the mounting bolts (2) and the oil lines (3) from the Turbocharger (1) of the engine block.
 Remove the starter (5) from the engine flywheel housing (4).
 Secure the engine to an engine support.

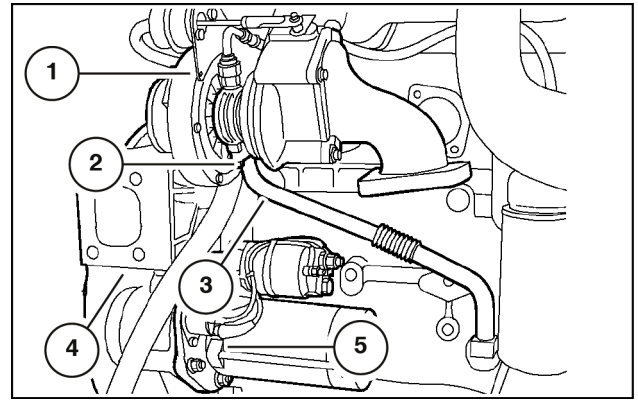

LAIL11CD1410A0A 4

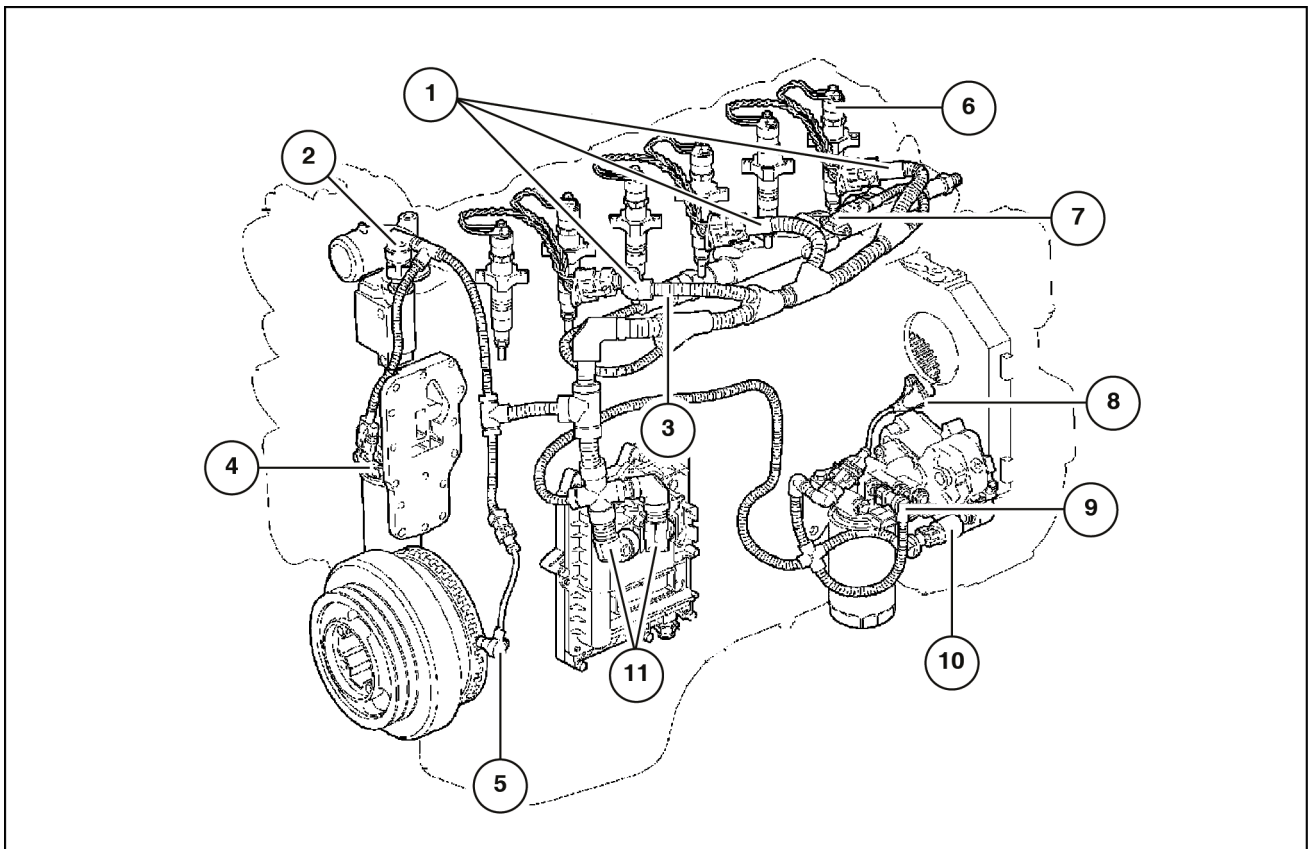

LAIL11CD1463F0A 5

- | | |
|---------------------------------------|-----------------------------------|
| 1. Injector fittings | 7. Pressure/temperature sensor |
| 2. Engine coolant temp sensor | 8. Camshaft sensor |
| 3. "Common rail" fuel pressure sensor | 9. Fuel heater temperature sensor |
| 4. Oil pressure-temperature sensor | 10. High pressure regulator |
| 5. Crankshaft rotation sensor | 11. Control unit EDC7UC31 |
| 6. Injector | |

6. Disconnect the battery cable. Disconnect the following connectors:

- Connectors (1) of the injector wiring (6).
- Engine coolant temperature sensor on the thermostat (2).
- "Common rail" fuel pressure sensor (3).
- Crankshaft rotation sensor (5).
- Temperature/pressure sensor (7).
- Camshaft sensor (8).
- High pressure regulator (10).
- Control unit EDC7UC31 (11).

7. Disconnect the "common rail" (2):

- Fuel line (4) according to the procedure in Step 3.
- Fuel lines (5).
- Injector manifolds (3).
- Remove the bolts (1). Disconnect the "common rail" (2).

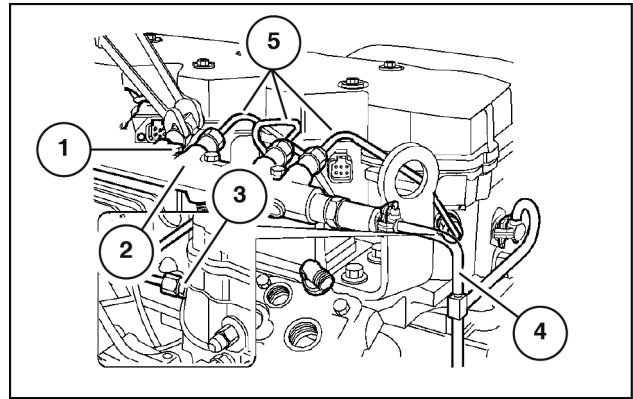

LAIL11CD1411A0A 6

8. Disconnect the line (2) from the fuel return pressure limiter (1), as shown in Step 3.

Remove the nut. Loosen the retaining collar. Disconnect the oil steam line (5). Remove the bolts (3). Remove the "blow-by" filter (4).

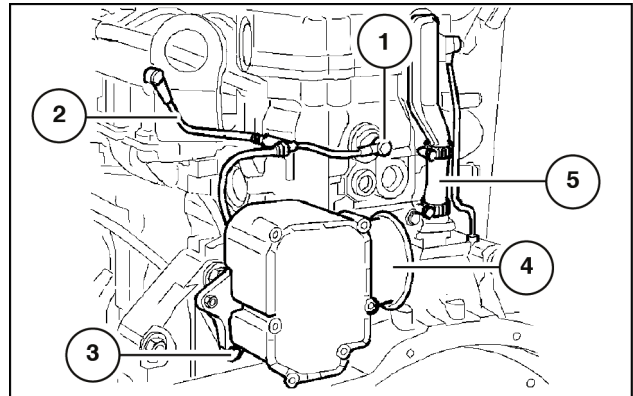

LAIL11CD1412A0A 7

9. Remove the nuts and the cover of the valve tappets, including the gasket.

Remove the bolts (1). Disconnect the wiring housing of the injectors (2), along with the gasket.

Remove the bolts (5). Shut down the pressure/temperature sensor (6).

Remove the nuts (3). Remove the fuel inlet connectors (4).

NOTICE: The fuel inlet connectors (4) should not be re-used. The fuel inlet connectors should be replaced with new fuel inlet connectors.

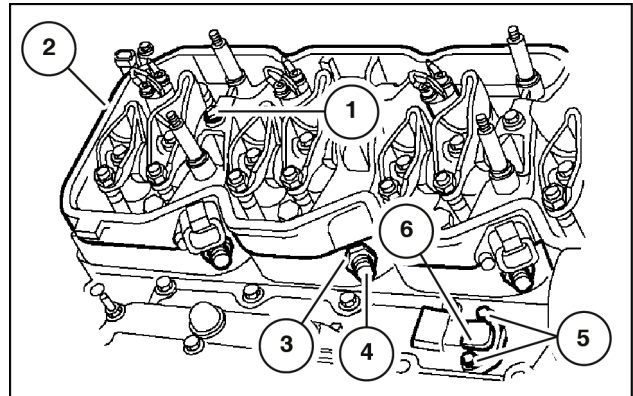

LAIL11CD1413A0A 8

10. Loosen the adjustment nuts of the valve tappets (1). Unscrew the adjusters. Remove the bolts (2). Remove the rocker arm assembly (3), which consists of the support (6), the rocker arms (4), and the shafts (5). Remove the valve bridges (7). Remove the rods (8).

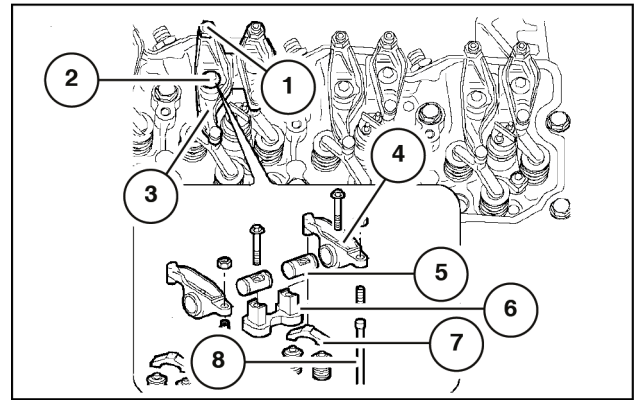

LAIL11CD1414A0A 9

11. Remove the injector mounting bolts. Use the Special Tool 380001099 (1) to remove the injectors (2) from the poppet.

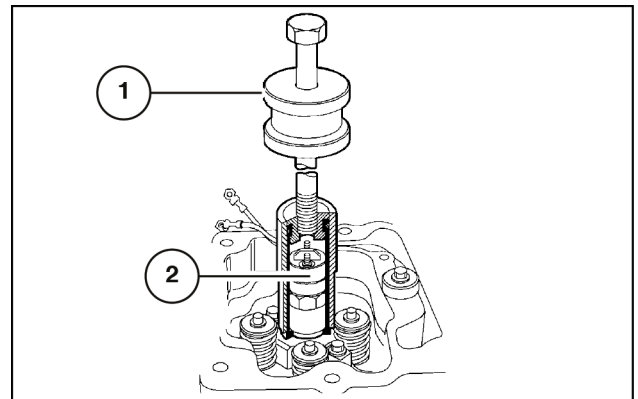

LAIL11CD1415A0A 10

12. If equipped, remove the deflector (5) from the turbocharger (1). Disconnect the oil line (3) from the oil filter support of the heat exchanger. Remove the nuts (2). Separate the turbocharger (1) from the exhaust manifold (4).

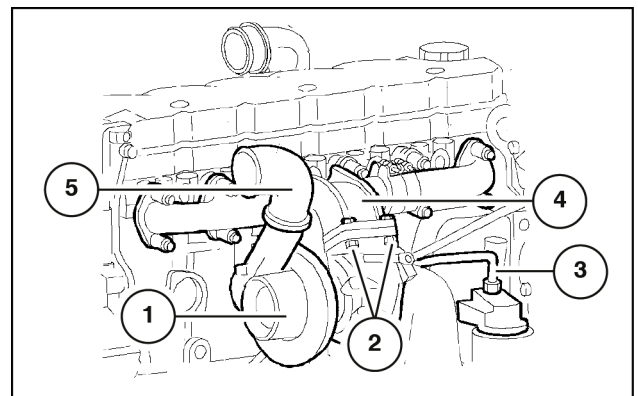

LAIL11CD1416A0A 11

13. Remove the mounting bolts (1). Remove the exhaust manifold in two sections (2) and (3) with the respective seals.

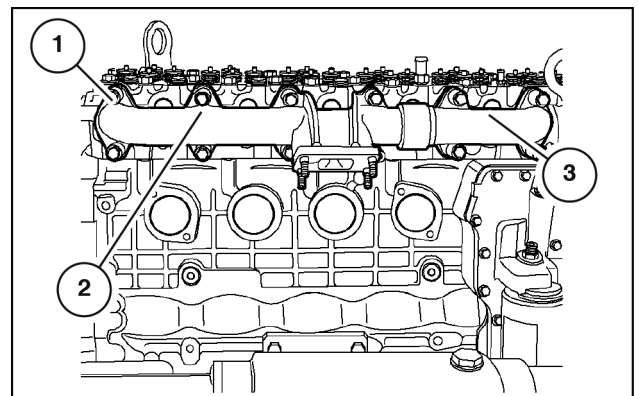

LAIL11CD1417A0A 12

14. Remove the bolts (1). Disconnect the intake manifold and the air deflector from the heater (2). Remove the bolts (4). Remove the thermostat housing (3). Remove the thermostat under the housing. Remove the mounting bolts (5) from the poppet (6).

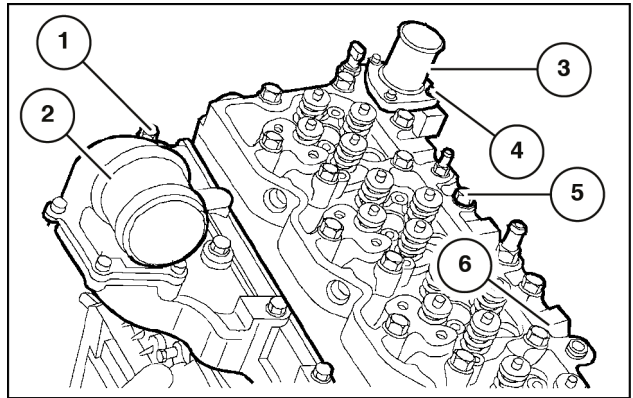

LAIL11CD1418A0A 13

15. Install supports (1) on the poppet. Use a hoist to remove the poppet from the cylinder block.

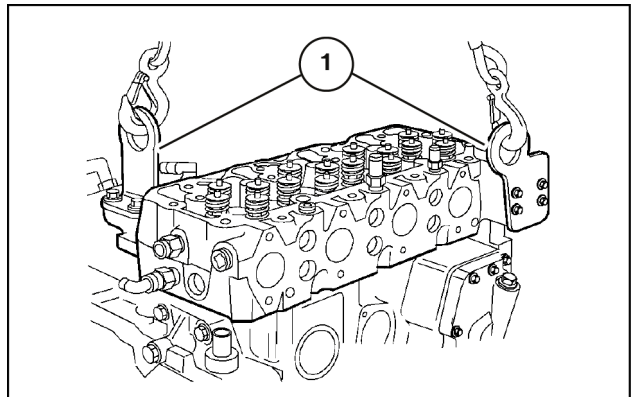

LAIL11CD1419A0A 14

16. Remove the head gasket (1).

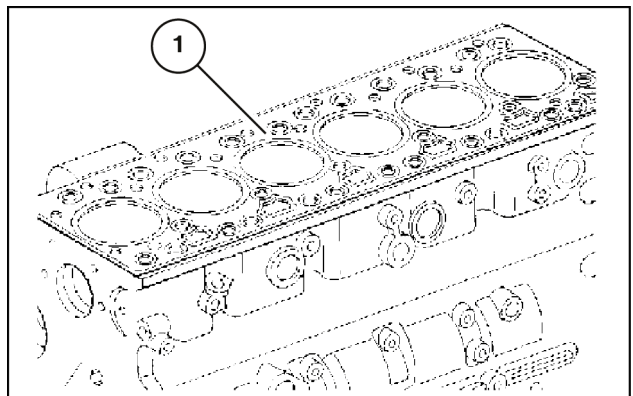

LAIL11CD1420A0A 15

17. Loosen the drive belt tensioner (2). Remove the drive belt (3) from the pulleys. Then remove the belt tensioner (2). Remove the bolts that secure the alternator to the bracket. Remove the alternator (1).

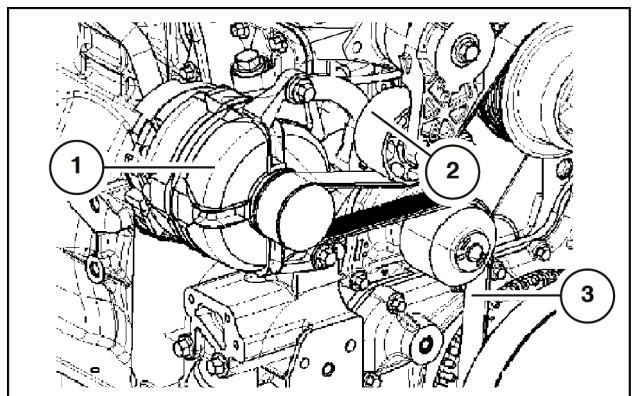

LAIL11CD1421A0A 16

18. Remove the bolts and the oil pressure/temperature sensor (2).
Remove the bolts. Then remove the heat exchanger support/oil filter (1), the intermediate plate (4), and the respective gaskets.
Remove the oil level sensor (3).

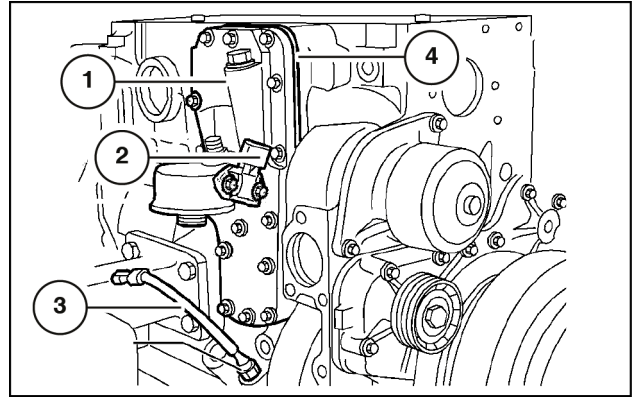

LAIL11CD1422A0A 17

19. Remove the bolts. Disconnect the control unit EDC7UC31 (1), including the heat exchanger.

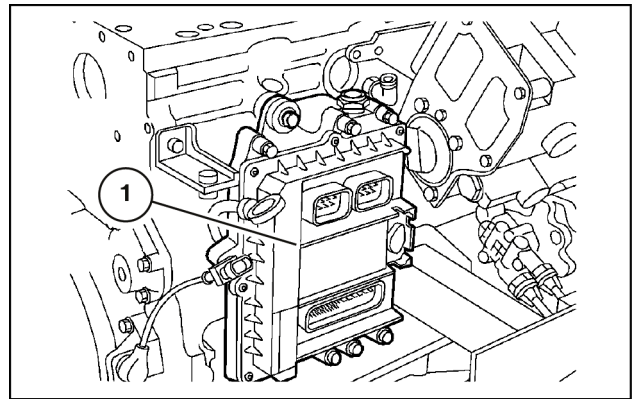

LAIL11CD1423A0A 18

20. Remove the nut. Disconnect the timing sensor (1).
Remove the nuts. Disconnect the high pump (3), including the supply pump (2).

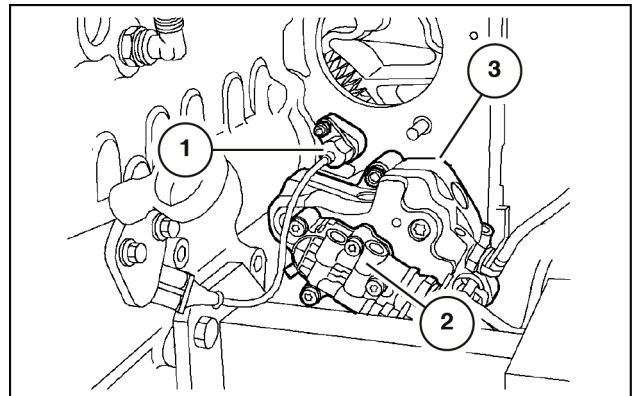

LAIL11CD1424A0A 19

21. Loosen the bolts from the engine flywheel (1). Do not remove the engine flywheel.

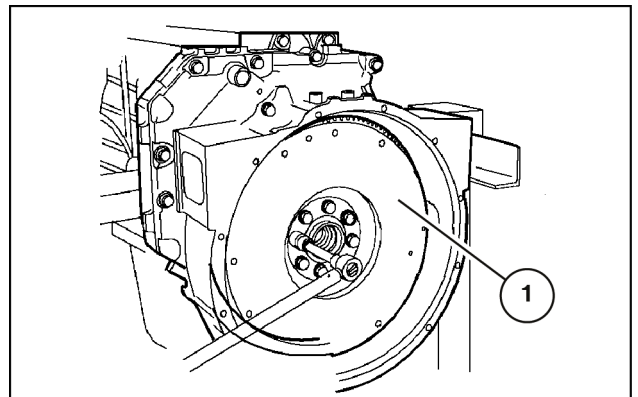

LAIL11CD1425A0A 20

22. Remove the bolts (3), the flywheel vibration damper (2), and the pulley (1).

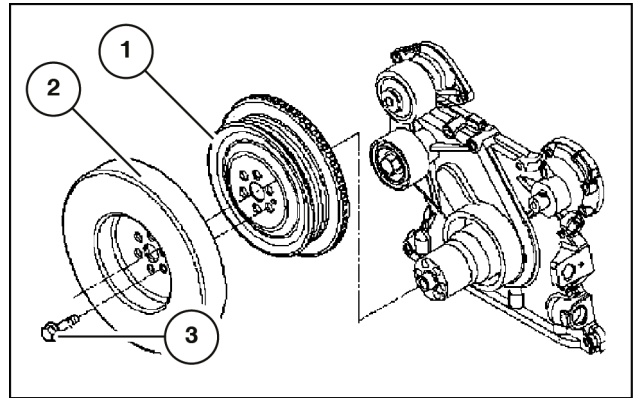

LAIL11CD1426A0A 21

23. Remove the bolts. Disconnect the water pump (1). Remove the bolt. Disconnect the engine rotation sensor (2).

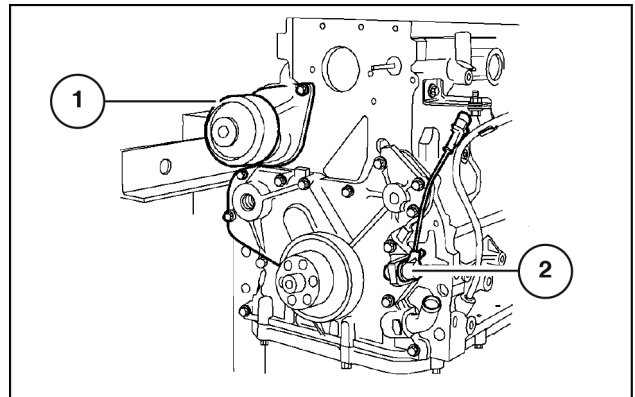

LAIL11CD1427A0A 22

24. Install the special tool **380000665 (4)** on the crankshaft (2).
 Work through the guide holes of the Special Tool **380000665 (4)** to drill the inner seal ring (1) with a **3.5 mm (0.14 in)** bit (A) to a depth of **5 mm (0.20 in)** (B).
 Bolt the six bolts supplied with the tool to the front cover of the crankshaft to secure the Special Tool **380000665 (4)** to the ring (1).
 Now tighten the bolt (3) to extract the seal ring (1).

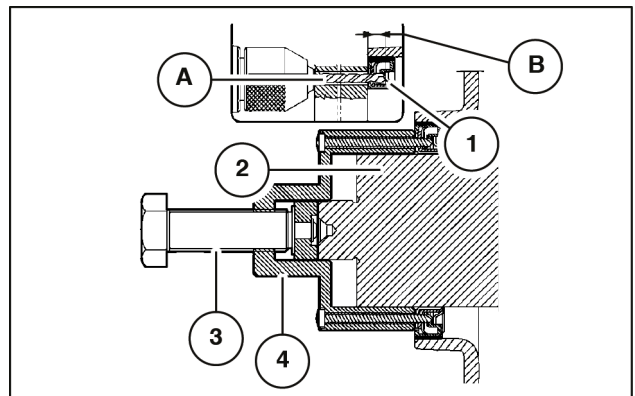

LAIL11CD1428A0A 23

25. Use the pry bar (3) and the lever (4) to remove the outer seal ring (2) from the front cover (1).

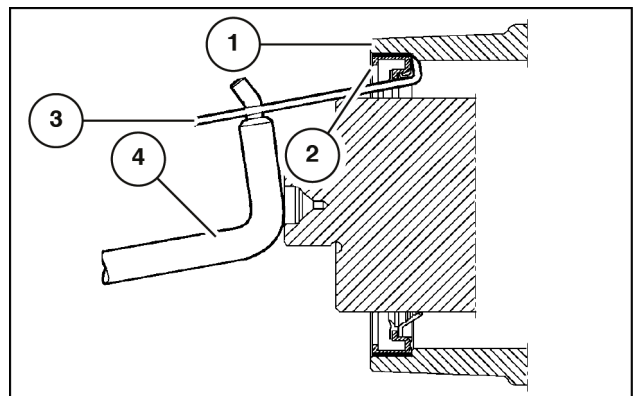

LAIL11CD1429A0A 24

26. Remove the bolts and the front cover (1).

NOTICE: Record the installation position of the bolts as they are different lengths.

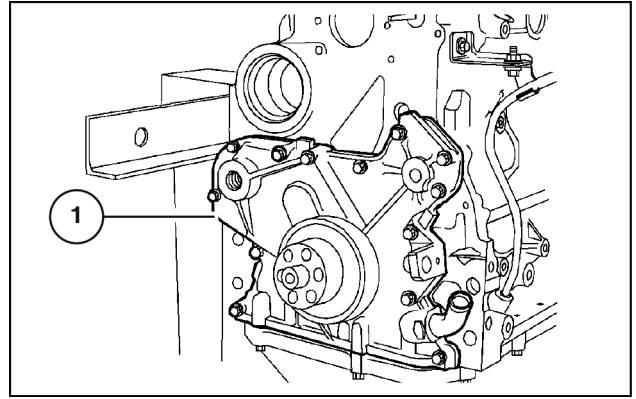

LAIL11CD1430A0A 25

27. Remove the bolts and the gear oil pump (1).

NOTICE: The oil pump (1) cannot be repaired.

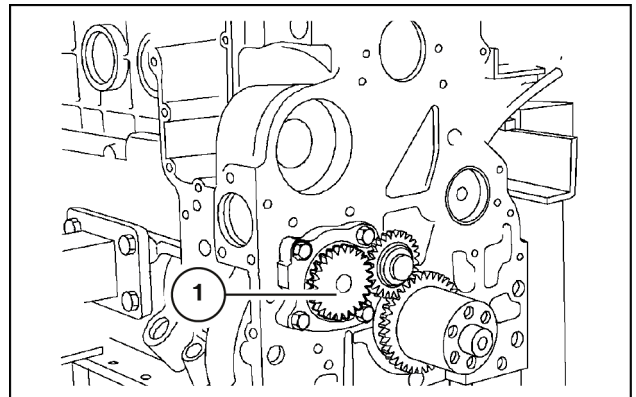

LAIL11CD1431A0A 26

28. Remove the tool (1) and the bolts that secure the engine flywheel (3) to the crankshaft (2).

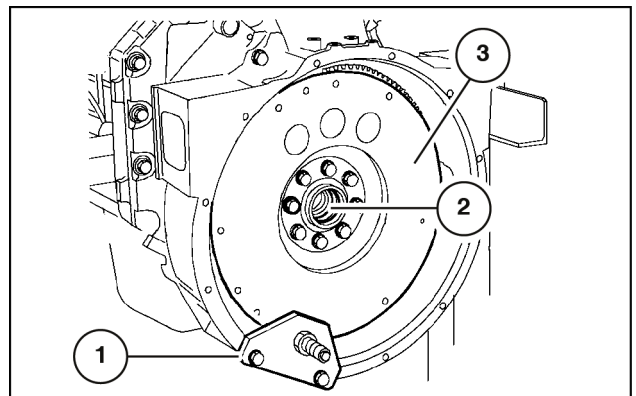

LAIL11CD1432A0A 27

29. Screw two pins (2) of an adequate length into the holes in the crankshaft (3).
Remove the engine flywheel (1) with a hoist.

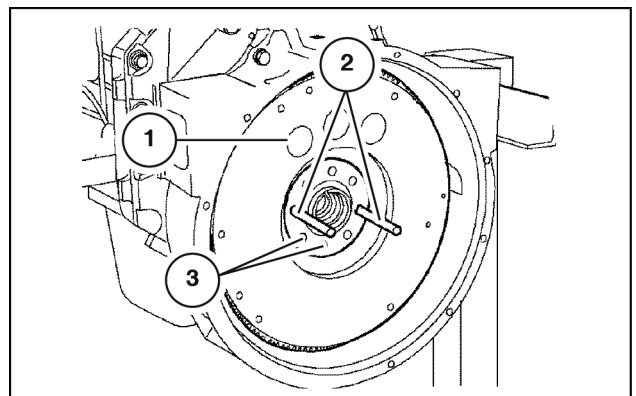

LAIL11CD1433A0A 28

30. Remove the bolts and the rear cover (1).

NOTICE: Record the installation position of the bolts as they are different lengths.

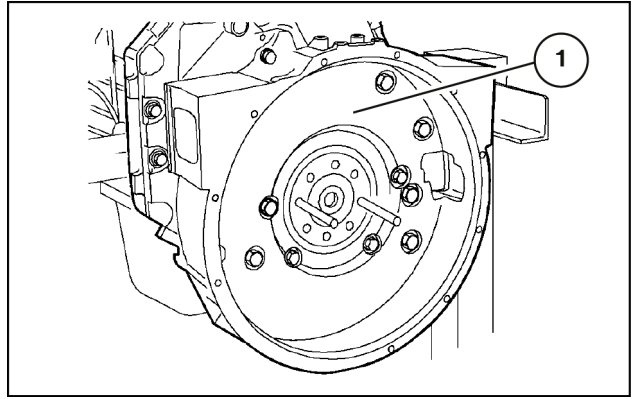

LAIL11CD1434A0A 29

31. Turn the engine upside down.

NOTE: For 667TA/EEG-/EEC-/EBF-/EED-/EDJ engines only.

Remove the bolts, the plate (2), and the crankcase (1).

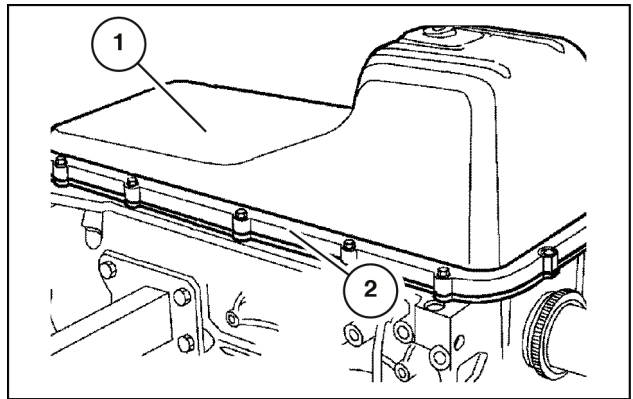

LAIL11CD1435A0A 30

32. Remove the bolts (1) and (4). Remove the oil suction tube (5). Remove the bolts (2). Remove the stiffening plate (3).

NOTE: For 667TA/EEG-/EEC-/EBF-/EED-/EDJ engines only.

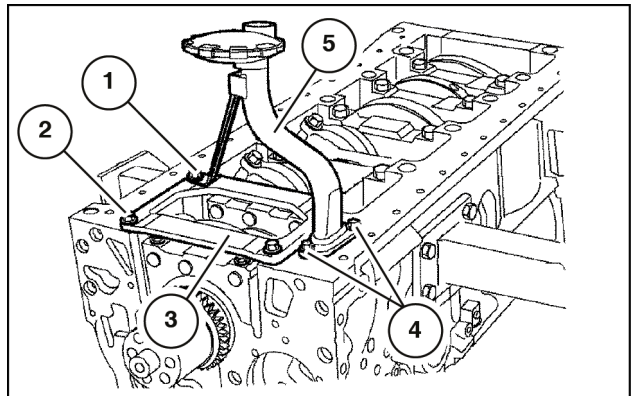

LAIL11CD1436A0A 31

33. Remove the bolts and the crankcase (1).

NOTE: For 667TA/EED-/EBD engines only.

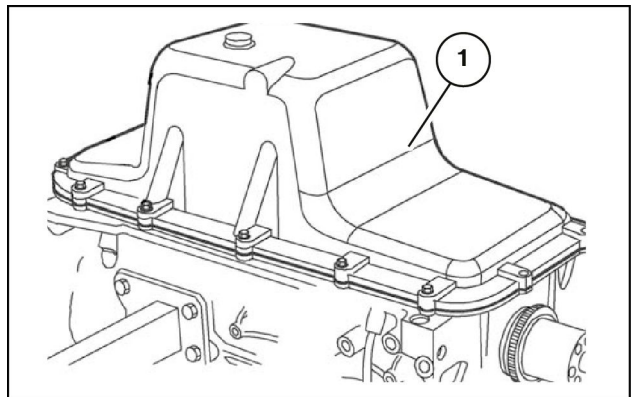

LAIL11CD1437A0A 32

34. Remove the bolts (1) and (4). Remove the oil suction tube (5). Remove the bolts (2). Remove the stiffening plate (3).

NOTE: For 667TA/EED-/EBD engines only.

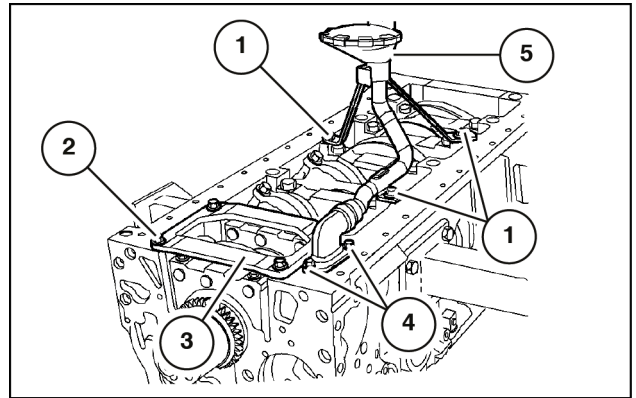

LAIL11CD1438A0A 33

35. Remove the bolts and the gears (2) from the camshaft (1).

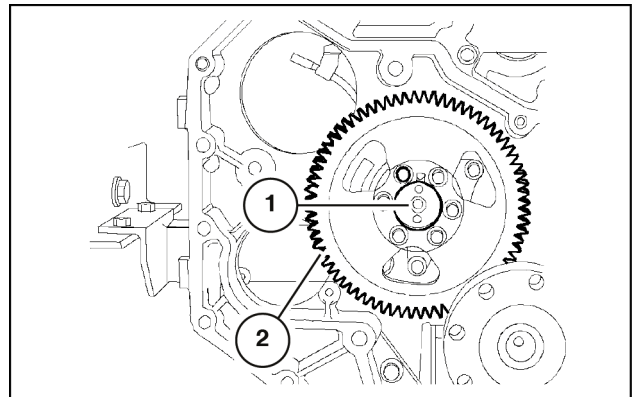

LAIL11CD1439A0A 34

36. Remove the bolts and the timing gearbox (1).

NOTICE: Record the installation position of the bolts as they are different lengths.

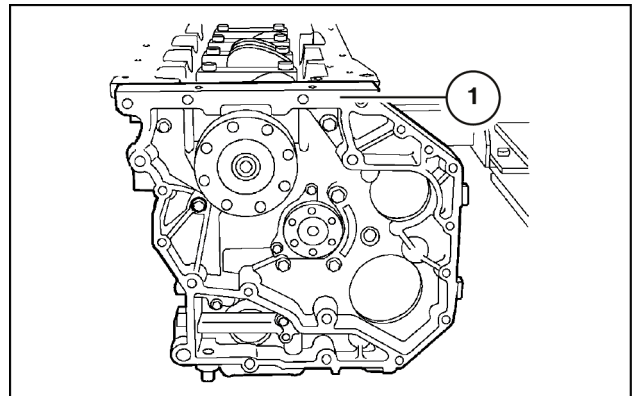

LAIL11CD1440A0A 35

37. Remove the bolts (1). Then remove the connecting rod covers (2).
Remove the plungers (complete, along with the connecting rods), from the engine block.

NOTICE: The bushings should be kept in their respective housings. If the bushings are to be used again, install the bushings in the same position they were in before they were removed.

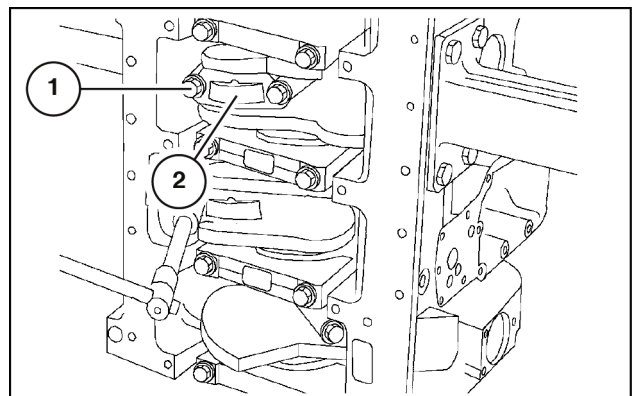

LAIL11CD1441A0A 36

38. Remove the bolts (1) and the main journal covers (2).

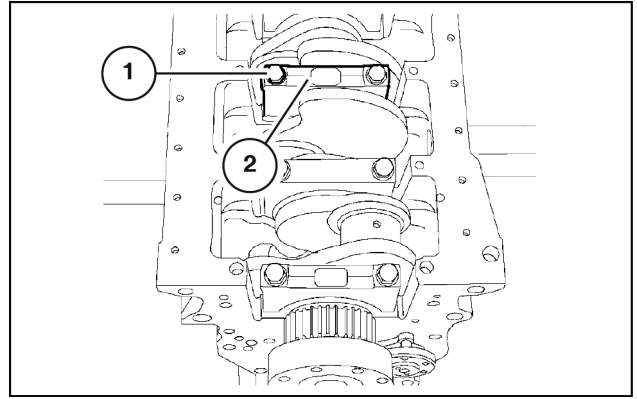

LAIL11CD1442A0A 37

39. The main journal covers (1) and their respective thrust bearings (2) have a lobe to control the end play of the crankshaft.

NOTICE: Record the mounting position of the main journals and the thrust bearings. If they are to be used again, install them in the same position they were in before they were removed.

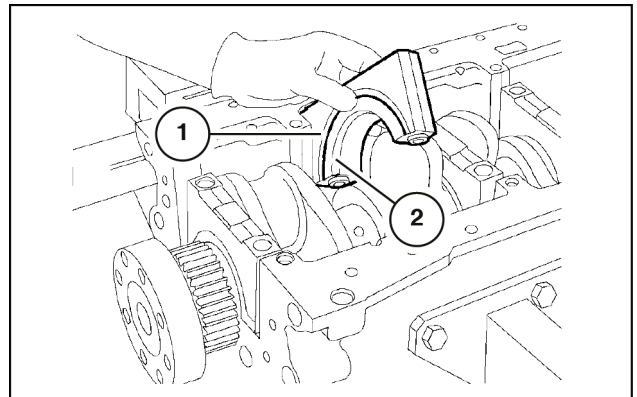

LAIL11CD1443A0A 38

40. Use a suitable tool (1) and a hoist to remove the crankshaft (2) from the engine block.

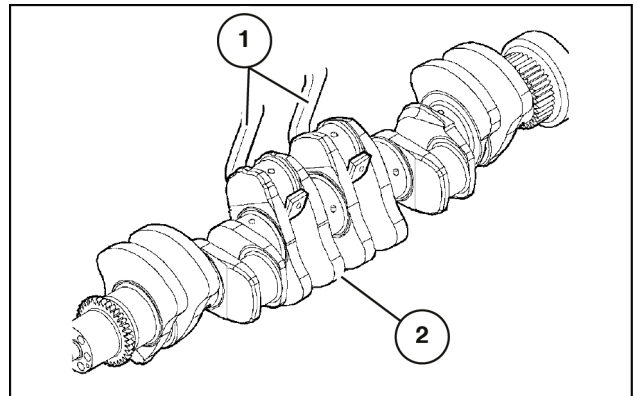

LAIL11CD1444A0A 39

41. Remove the main bearings (1).
Remove the bolts (2) and the oil nipples (3).

NOTICE: Record the mounting position of the main journals and the thrust bearings. If they are to be used again, install them in the same position they were in before they were removed.

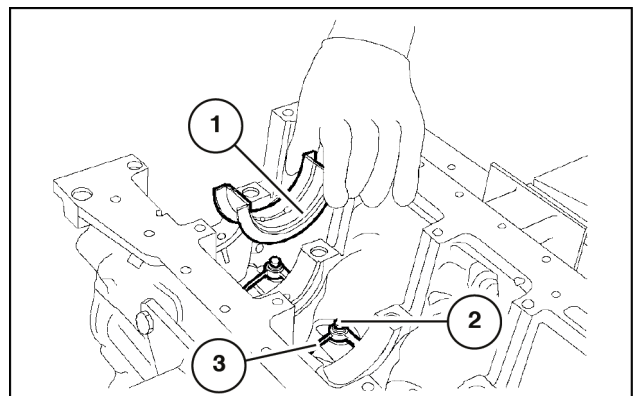

LAIL11CD1445A0A 40

42. Remove the bolts, the camshaft **(2)**, and the retaining plate **(1)**.

NOTICE: Record the assembly position of the plate **(1)**.

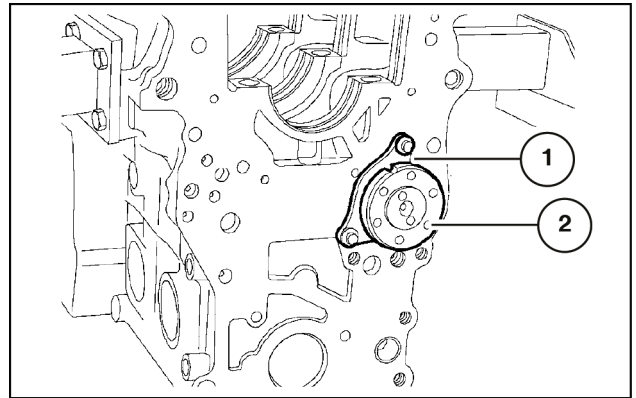

LAIL11CD1446A0A 41

43. Carefully remove the camshaft **(1)** from the engine block.

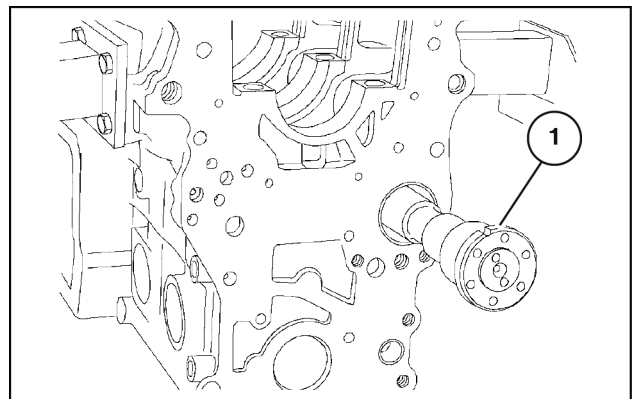

LAIL11CD1447A0A 42

44. Remove the tappets **(1)** from the engine block.

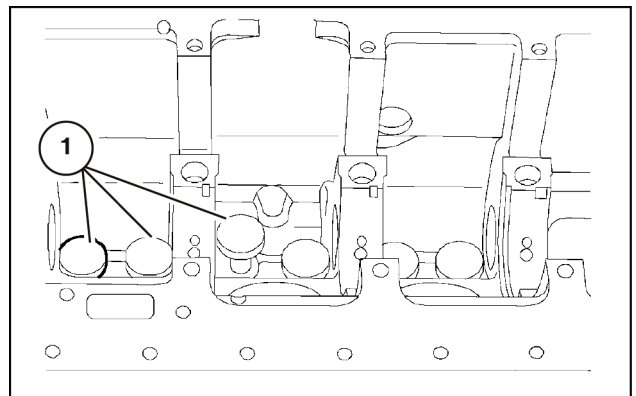

LAIL11CD1448A0A 43

Engine - Assemble

1150L

LA

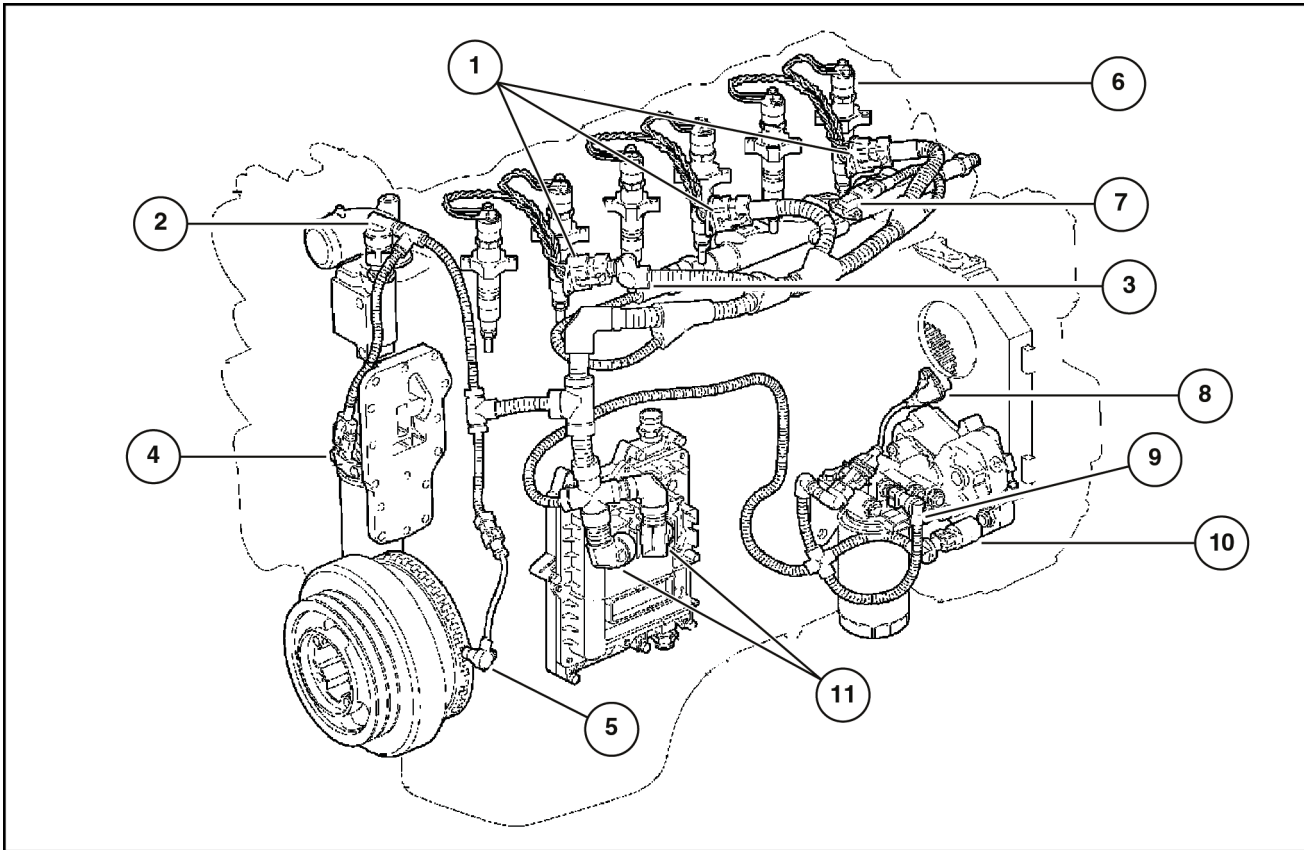

LAIL11CD1585F0A 1

Fittings of the wiring harness to the engine

1. Electro-injector fittings
 2. Engine coolant temp sensor
 3. "Common rail" fuel pressure sensor
 4. Oil pressure-temperature sensor
 5. Crankshaft sensor
 6. Electro-injector
 7. Pressure and temperature sensor
 8. Camshaft sensor
 9. Temperature and heater sensor
 10. High pressure regulator
 11. Control unit EDC7UC31
1. Re-install the engine wiring harness. Connect the wiring connectors (1) of the electro-injectors (6), the air temperature/pressure sensor (7), the "common rail" pressure sensor (3), electronic control unit EDC7UC31 (11), the high pressure pump sensor (10), the camshaft sensor (8), the engine coolant temperature sensor on the thermostat (2), and the crankshaft sensor (5). Install the hoist hooks of the rocker arm lever to the engine. Hook the rocker arm lever to a hoist. Separate the engine from the rotary stand. Remove the brackets.



Suggest:

If the above button click is invalid.

Please download this document

first, and then click the above link

to download the complete manual.

Thank you so much for reading

2. Complete the installation of the engine as follows:
From the right-hand side:

- Install the starter motor (5) on the engine flywheel housing (4). Tighten the fixing nuts to the specified torque of **50 - 60 N·m (36.9 - 44.3 lb ft)**.
- Install the oil line (3) with a new seal ring on the engine block. Secure the line to the turbocharger (1) with the bolts (2). Tighten the bolts to the specified torque of **20 - 30 N·m (14.8 - 22.1 lb ft)**.

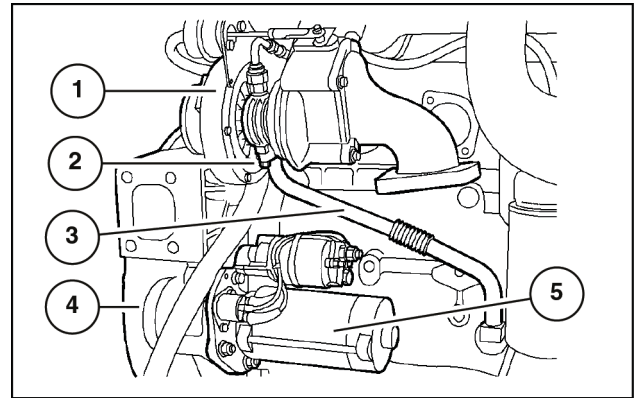

LAIL11CD1544A0A 2

3. Install the bracket (2) and the fuel filter bracket (1) on the engine block. Tighten the bolts (3) to the torque specified in the repair manual.

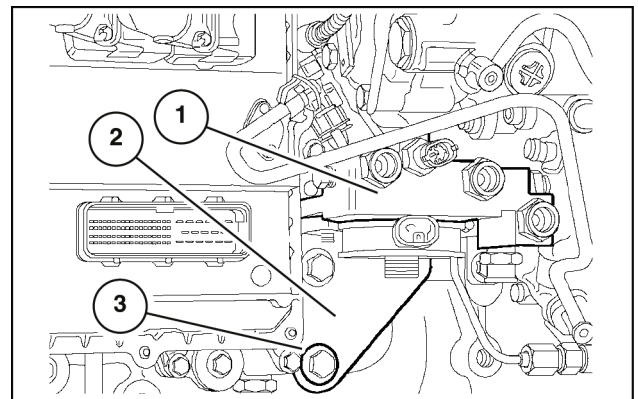

LAIL11CD1545A0A 3

4. Hand screw the fuel filter to the bracket (1). Tighten the fuel filter until the gasket touches the bracket. Then tighten the fuel filter another 3/4 of a turn. Connect the fuel lines (2), (3), and (4) to the appropriate bracket fittings (1), as shown in the figure below (Step 3).

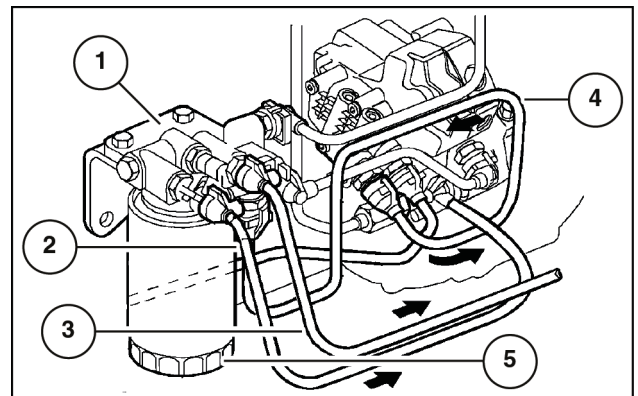

LAIL11CD1546A0A 4

5. Press the clip (1) as shown in (Figure B).
After you connect the lines, readjust the clip (1) to the initial lock position (A) to avoid deformities.

NOTE: After you complete the installation, fill the engine with the oil lubricant oil.

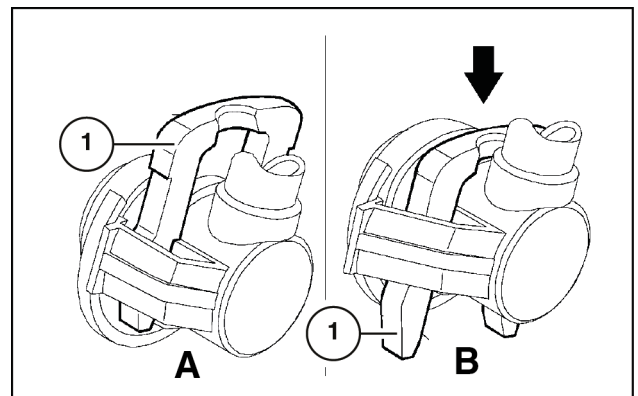

LAIL11CD1547A0A 5

<https://www.ebooklibonline.com>

Hello dear friend!

Thank you very much for reading.

Enter the link into your browser.

The full manual is available for immediate download.

<https://www.ebooklibonline.com>