

# 1150H CRAWLER

## Service Manual

### 7-16200

## Table of Contents

Description	Section No.	Publication Form No.
<b>General</b>		<b>Tab 1</b>
Section Index - General		7-18400
Standard Torque Specifications	1001	8-71602
Fluids and Lubricants	1002	7-17480
Loctite Product Chart		8-98902
<b>Engines</b>		<b>Tab 2</b>
Section Index - Engines		7-18410
Stall Tests	2001	7-17490
Engine and Radiator Removal and Installation	2002	7-18420
<b>Fuel System</b>		<b>Tab 3</b>
Section Index - Fuel System		7-18430
<b>Electrical</b>		<b>Tab 4</b>
Section Index - Electrical		7-18440
Removal and Installation of Electrical Components	4000	7-18450
Electrical Troubleshooting	4001	7-17980
Battery	4003	8-11361
Instrument Panel	4004	7-17650
Alternator	4007	7-18070
<b>Tracks</b>		<b>Tab 5</b>
Section Index - Tracks		7-18460
Undercarriage Fundamentals	5001	7-17690
Inspection of Track System Components	5501	7-18470
Case Lubricated Track	5504	7-17700
Track Frame and Suspension	5507	7-18490
Idler, Track Adjuster, and Recoil Housing	5508	7-18500
Sprocket	5509	7-18510
Track Roller	5511	7-18520
<b>Power Train</b>		<b>Tab 6</b>
Section Index - Power Train		7-18530
Removal and Installation of Power Train Components	6000	7-18540
Transmission Schematic and Troubleshooting	6002	7-17510
Transmission Charging Pump	6005	7-18550
Transmission Control Valve	6007	7-17790
High/Low Range Control Valve	6008	7-18560

CASE CORPORATION  
700 State Street  
Racine, WI 53404 U.S.A.

CASE CANADA CORPORATION  
3350 South Service Road  
Hamilton, ON L7N 3M6 CANADA

Bur 7-18390

**Reprinted**

Copyright © 2000 Case Corporation  
Printed in U.S.A.  
September, 2000

# Table of Contents

Description	Section No.	Publication Form No.
Torque Converter	6010	7-18570
Transmission	6016	7-18580
Final Drives	6017	7-18590
<b>Brakes</b>	<b>Tab 7</b>	
Section Index - Brakes		7-18600
Removal and Installation of Brake Valve and Removing Air from Brake System	7001	7-17850
Brake Valve	7002	7-17860
Brakes	7003	7-18620
<b>Hydraulics</b>	<b>Tab 8</b>	
Section Index - Hydraulics		7-18630
Removal and Installation of Hydraulic Components	8001	7-18640
Hydraulic Schematic and Troubleshooting	8002	7-17520
Cleaning the Hydraulic System	8003	7-49640
Equipment Pump	8005	7-18650
Dozer Control Valve	8007	7-18660
Cylinders	8008	7-18670
<b>Mounted Equipment</b>	<b>Tab 9</b>	
Section Index - Mounted Equipment		7-18680
Pedals, Levers, and Linkages	9002	7-17530
Air Conditioning Troubleshooting and System Checks for Systems with HFC134a Refrigerant	9003	7-18290
Air Conditioning System Service - Refrigerant Recovery, System Evacuation, and Recharging for Systems with HFC134a Refrigerant	9004	7-18300
Removal and Installation of Air Conditioning System Components for Systems with HFC134a Refrigerant	9005	7-18310
Air Conditioning Compressor and Clutch for Systems with HFC134a Refrigerant	9006	7-18320
Dozer Blade	9007	7-18690
ROPS Cab, ROPS Canopy, Seat Mounting, and Seat Belts	9008	7-18700
Ripper	9011	7-18710
<b>Schematic Set</b>		
Electrical and Hydraulic Schematic Foldout	In Rear Pocket	7-17540

**NOTE:** Case Corporation reserves the right to make improvements in design or changes in specifications at any time without incurring any obligation to install them on units previously sold.

# SECTION INDEX

## GENERAL

<b>Section Title</b>	<b>Section Number</b>
Standard Torque Specifications .....	1001
Fluid and Lubricants .....	1002
Loctite Product Chart	

**CASE CORPORATION**  
700 State Street  
Racine, WI 53404 U.S.A.

**CASE CANADA CORPORATION**  
3350 South Service Road  
Hamilton, ON L7N 3M6 CANADA

Bur 7-18400

Copyright © 2000 Case Corporation  
Printed in U.S.A.  
September, 2000

**<https://www.ebooklibonline.com>**

Hello dear friend!

Thank you very much for reading.

Enter the link into your browser.

The full manual is available for immediate download.

**<https://www.ebooklibonline.com>**

# Section 1001

## GENERAL TORQUE SPECIFICATIONS

## TORQUE SPECIFICATIONS - DECIMAL HARDWARE

Use the torques in this chart when special torques are not given. These torques apply to fasteners with both UNC and UNF threads as received from suppliers dry, or when lubricated with engine oil. Not applicable if special graphities, Molydisulfide greases, or other extreme pressure lubricants are used.

Grade 5 Bolts, Nuts, and Studs		
		
Size	Pound-Inches	Newton metres
1/4 inch	108 to 132	12 to 15
5/16 inch	204 to 252	23 to 28
3/8 inch	420 to 504	48 to 57
Size	Pound-Feet	Newton metres
7/16 inch	54 to 64	73 to 87
1/2 inch	80 to 96	109 to 130
9/16 inch	110 to 132	149 to 179
5/8 inch	150 to 180	203 to 244
3/4 inch	270 to 324	366 to 439
7/8 inch	400 to 480	542 to 651
1.0 inch	580 to 696	787 to 944
1-1/8 inch	800 to 880	1085 to 1193
1-1/4 inch	1120 to 1240	1519 to 1681
1-3/8 inch	1460 to 1680	1980 to 2278
1-1/2 inch	1940 to 2200	2631 to 2983

Grade 8 Bolts, Nuts, and Studs		
		
Size	Pound-Inches	Newton metres
1/4 inch	144 to 180	16 to 20
5/16 inch	288 to 348	33 to 39
3/8 inch	540 to 648	61 to 73
Size	Pound-Feet	Newton metres
7/16 inch	70 to 84	95 to 114
1/2 inch	110 to 132	149 to 179
9/16 inch	160 to 192	217 to 260
5/8 inch	220 to 264	298 to 358
3/4 inch	380 to 456	515 to 618
7/8 inch	600 to 720	814 to 976
1.0 inch	900 to 1080	1220 to 1465
1-1/8 inch	1280 to 1440	1736 to 1953
1-1/4 inch	1820 to 2000	2468 to 2712
1-3/8 inch	2380 to 2720	3227 to 3688
1-1/2 inch	3160 to 3560	4285 to 4827

**NOTE:** Use thick nuts with Grade 8 bolts.

## TORQUE SPECIFICATIONS - METRIC HARDWARE

Use the following torques when specifications are not given.

These values apply to fasteners with coarse threads as received from supplier, plated or unplated, or when lubricated with engine oil. These values do not apply if graphite or Molydisulfide grease or oil is used.

<b>Grade 8.8 Bolts, Nuts, and Studs</b>		
		
Size	Pound-Inches	Newton metres
M4	24 to 36	3 to 4
M5	60 to 72	7 to 8
M6	96 to 108	11 to 12
M8	228 to 276	26 to 31
M10	456 to 540	52 to 61
Size	Pound-Feet	Newton metres
M12	66 to 79	90 to 107
M14	106 to 127	144 to 172
M16	160 to 200	217 to 271
M20	320 to 380	434 to 515
M24	500 to 600	675 to 815
M30	920 to 1100	1250 to 1500
M36	1600 to 1950	2175 to 2600

<b>Grade 10.9 Bolts, Nuts, and Studs</b>		
		
Size	Pound-Inches	Newton metres
M4	36 to 48	4 to 5
M5	84 to 96	9 to 11
M6	132 to 156	15 to 18
M8	324 to 384	37 to 43
Size	Pound-Feet	Newton metres
M10	54 to 64	73 to 87
M12	93 to 112	125 to 150
M14	149 to 179	200 to 245
M16	230 to 280	310 to 380
M20	450 to 540	610 to 730
M24	780 to 940	1050 to 1275
M30	1470 to 1770	2000 to 2400
M36	2580 to 3090	3500 to 4200

### Grade 12.9 Bolts, Nuts, and Studs

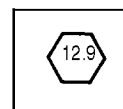

Usually the torque values specified for grade 10.9 fasteners can be used satisfactorily on grade 12.9 fasteners.

## TORQUE SPECIFICATIONS - STEEL HYDRAULIC FITTINGS

Tube OD Hose ID	Thread Size	Pound- Inches	Newton metres
<b>37 Degree Flare Fitting</b>			
1/4 inch 6.4 mm	7/16-20	72 to 144	8 to 16
5/16 inch 7.9 mm	1/2-20	96 to 192	11 to 22
3/8 inch 9.5 mm	9/16-18	120 to 300	14 to 34
1/2 inch 12.7 mm	3/4-16	180 to 504	20 to 57
5/8 inch 15.9 mm	7/8-14	300 to 696	34 to 79
Tube OD Hose ID	Thread Size	Pound- Inches	Newton metres
3/4 inch 19.0 mm	1-1/16-12	40 to 80	54 to 108
7/8 inch 22.2 mm	1-3/16-12	60 to 100	81 to 135
1.0 inch 25.4 mm	1-5/16-12	75 to 117	102 to 158
1-1/4 inch 31.8 mm	1-5/8-12	125 to 165	169 to 223
1-1/2 inch 38.1 mm	1-7/8-12	210 to 250	285 to 338

Tube OD Hose ID	Thread Size	Pound- Inches	Newton metres
<b>Straight Threads with O-ring</b>			
1/4 inch 6.4 mm	7/16-20	144 to 228	16 to 26
5/16 inch 7.9 mm	1/2-20	192 to 300	22 to 34
3/8 inch 9.5 mm	9/16-18	300 to 480	34 to 54
1/2 inch 12.7 mm	3/4-16	540 to 804	57 to 91
Tube OD Hose ID	Thread Size	Pound- Inches	Newton metres
5/8 inch 15.9 mm	7/8-14	58 to 92	79 to 124
3/4 inch 19.0 mm	1-1/16-12	80 to 128	108 to 174
7/8 inch 22.2 mm	1-3/16-12	100 to 160	136 to 216
1.0 inch 25.4 mm	1-5/16-12	117 to 187	159 to 253
1-1/4 inch 31.8 mm	1-5/8-12	165 to 264	224 to 357
1-1/2 inch 38.1 mm	1-7/8-12	250 to 400	339 to 542

<b>Split Flange Mounting Bolts</b>		
Size	Pound- Inches	Newton metres
5/16-18	180 to 240	20 to 27
3/8-16	240 to 300	27 to 34
7/16-14	420 to 540	47 to 61
Size	Pound- Feet	Newton metres
1/2-13	55 to 65	74 to 88
5/8-11	140 to 150	190 to 203

# Section 2002

## ENGINE AND RADIATOR REMOVAL AND INSTALLATION

CASE CORPORATION  
700 State Street  
Racine, WI 53404 U.S.A.

CASE CANADA CORPORATION  
3350 South Service Road  
Burlington, ON L7N 3M6 CANADA

Bur 7-18420

Copyright © 2000 Case Corporation  
Printed in U.S.A.  
September, 2000

## ENGINE

### Removal

#### STEP 1

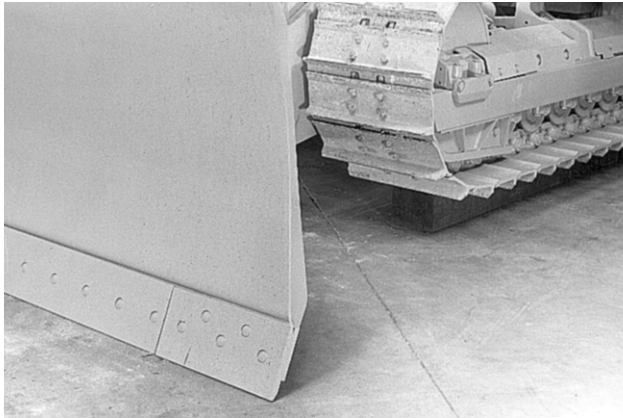

RP95H150

Put the crawler on blocks at least 203 mm (8 inches) high to allow the C-frame to drop below the bolts securing the radiator shroud. An alternate method is to remove the dozer blade and C-frame as an assembly.

#### STEP 2



RP95H151

Raise and support the dozer blade. Use a floor jack to support the undercarriage guards. Remove the guards from under the engine and torque converter.

#### STEP 3



RP95H150

Remove the supports from under the dozer blade. Lower the dozer blade to the ground.

#### STEP 4



BD99N041

Put the battery disconnect switch in the OFF position.

#### STEP 5

Get three 20 liter (5 gallon) containers. Remove the drain plug in the bottom of the transmission housing. Drain the transmission oil into the clean containers. Store the transmission oil in a safe and clean area if the oil is to be reused.

**STEP 6**



BD00F153

If the machine is equipped with a brush guard, connect suitable lifting equipment to brush guard. Remove four bolts and lock nuts securing brush guard. Remove brush guard.

**STEP 7**

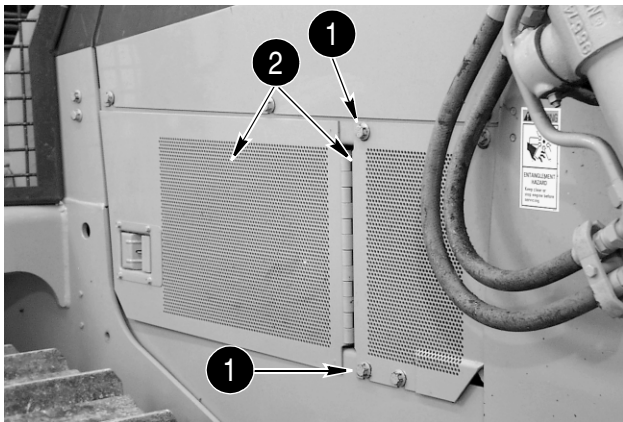

BD00H006

Remove bolts (1) securing the upper RH and LH side shield covers (2). Remove both side shield covers.

**STEP 8**

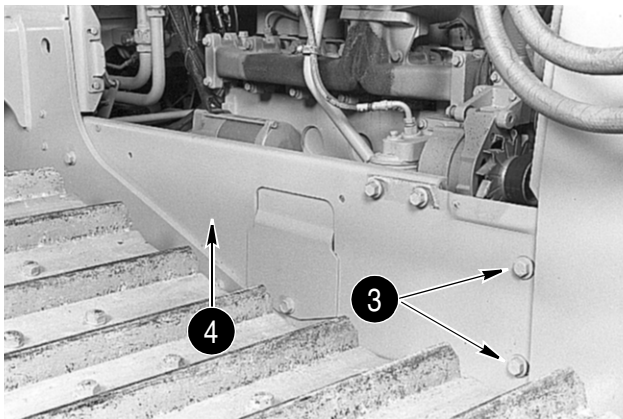

RP95H122

Remove the bolts (3) securing the lower RH and LH side shield covers (4). Remove the side shield covers.

**STEP 9**

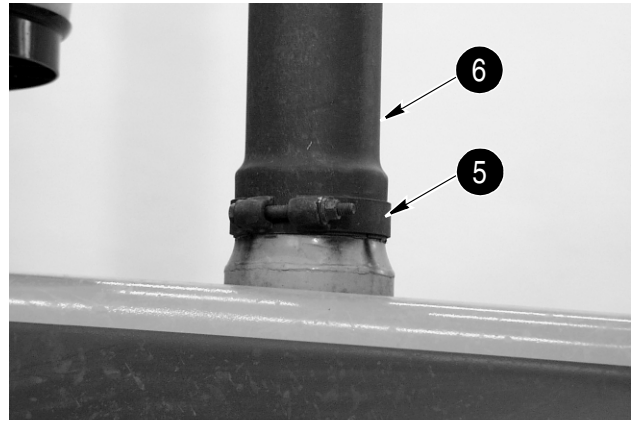

BD00H008

Loosen the clamp (5) securing the exhaust pipe (6). Remove the exhaust pipe.

**STEP 10**

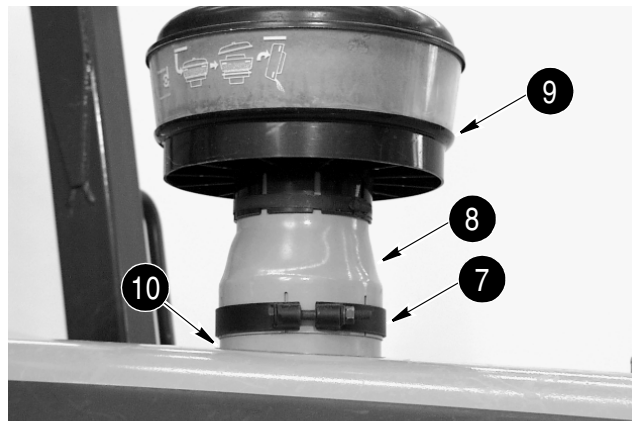

BD00H009

Loosen the clamp (7) securing the air cleaner stack (8). Remove the air cleaner stack (8) and pre-cleaner (9) as an assembly then remove the pad (10).

**STEP 11**

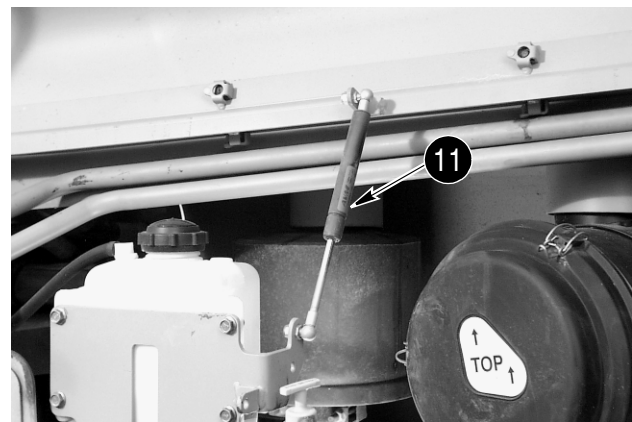

BD00H014

Open the LH engine hood. Remove the lock nut securing the bottom of the spring (11). Support the hood and disconnect the bottom of the spring from the bracket. Close but do not latch the hood.

**STEP 12**

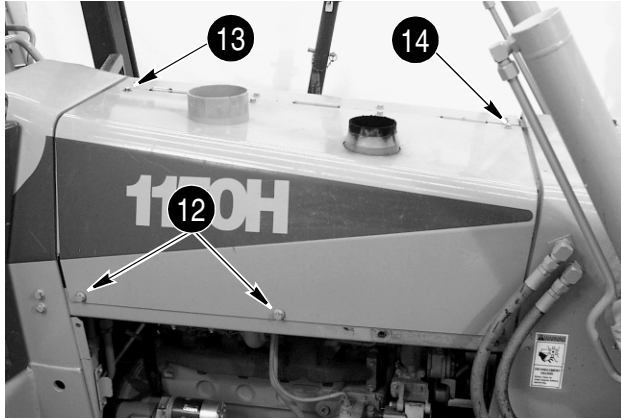

BD00H013

Loosen the lower bolts (12). Remove the lock nut, bolt (13), and washer from the rear of the RH engine hood. Remove the lock nut, washers, plate, and bolt (14) from the front of the RH engine hood. Remove the RH and LH engine hoods as an assembly.

**STEP 13**

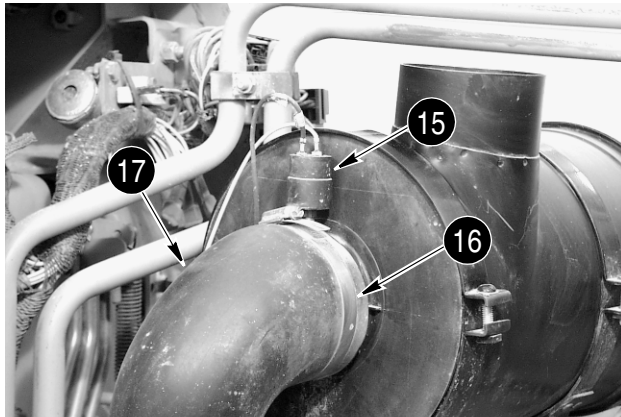

BD00H016

Identify, tag, and disconnect the two wires from the air restriction switch (15). Loosen the clamps (16) on both ends of the air cleaner hose (17). Disconnect the hose from the air cleaner assembly.

**STEP 14**

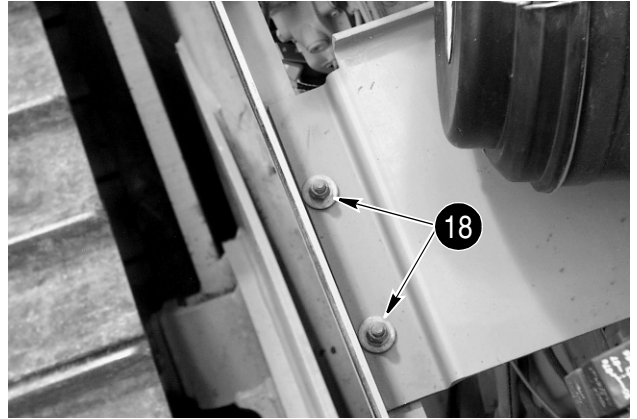

BD00H024

Remove the four lock nuts (18), washers, and bolts securing the air cleaner bracket. Remove the air cleaner and bracket as an assembly. Remove the air cleaner hose (17) from the turbocharger inlet.

**STEP 15**

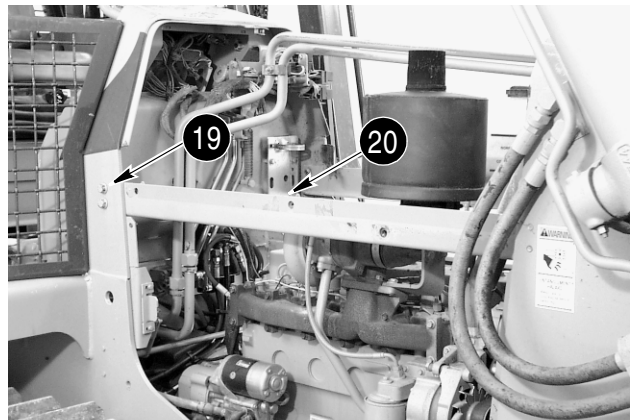

BD00H049

Remove the four bolts (19) securing the RH support panel (20). Remove the RH support panel.

**STEP 16**

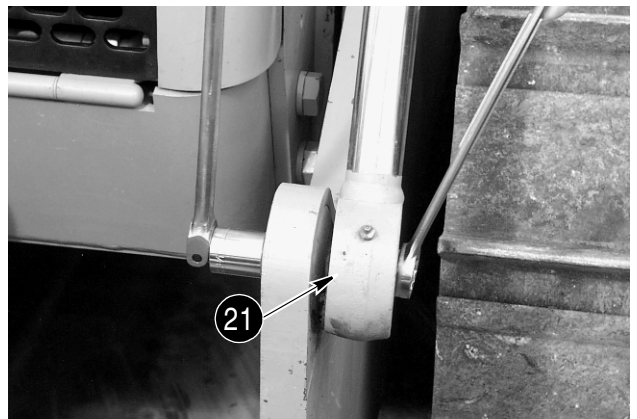

BD00H062

Remove the lock nut, washer, bolt, washer, and mount securing the LH lift cylinder rod (21). Repeat this step for the RH lift cylinder rod.

### STEP 17



BD00H055

Remove the two bolts (22) securing the grille (27). Lower the grille.

### STEP 18



BD00H056

Install lifting eyes in the two holes in the grille (27). Connect suitable lifting equipment to the lifting eyes.

### STEP 19

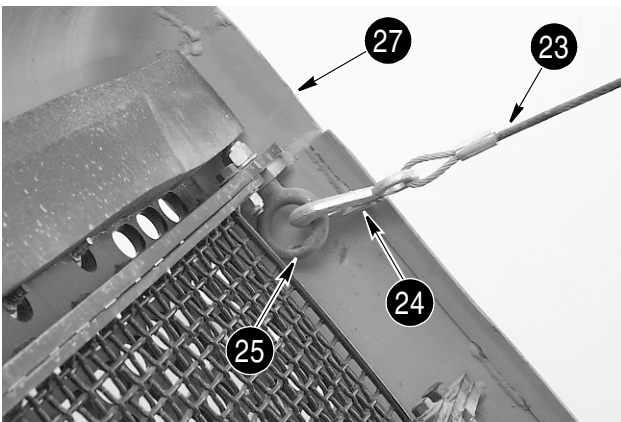

BD00E070

Raise the grille (27) to get slack in the cable (23). Disconnect the hook (24) from the eyebolt (25).

### STEP 20

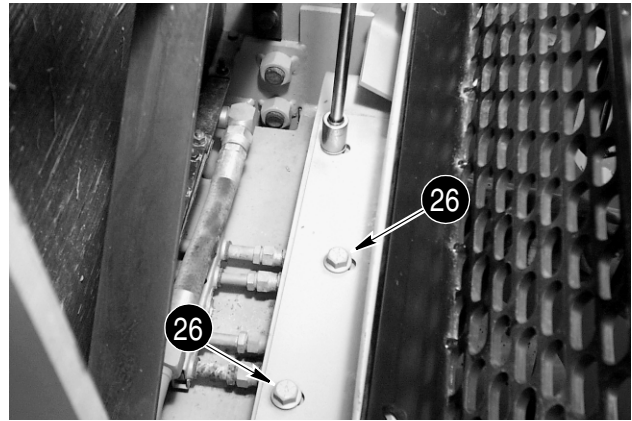

BD00H059

Lower the grille (27) to gain access to the three bolts (26), lock nuts, and washers securing the grille hinge to the machine. Remove the three lock nuts and washers; DO NOT remove the bolts.

### STEP 21

Raise the grille (27) until the three bolts (26) are free of the machine. Remove the bolts from the hinge. Remove the grille from the machine.

### STEP 22

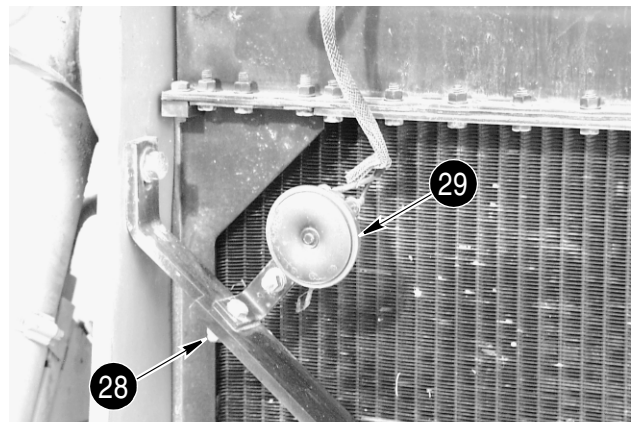

BD00H065

Remove the nut (28) securing the horn (29) to the cross brace.

**STEP 23**

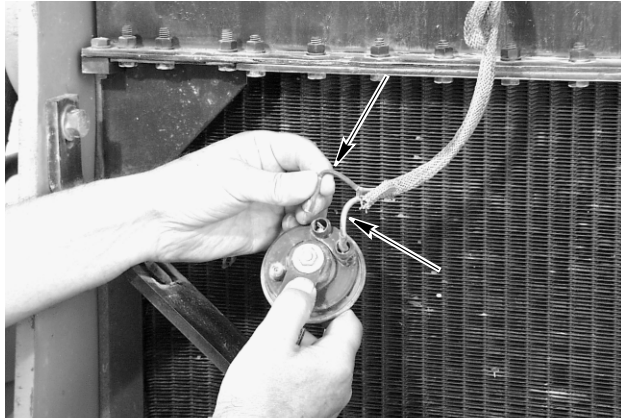

BD00H066

Identify, tag, and disconnect two wires from the horn.

**STEP 24**

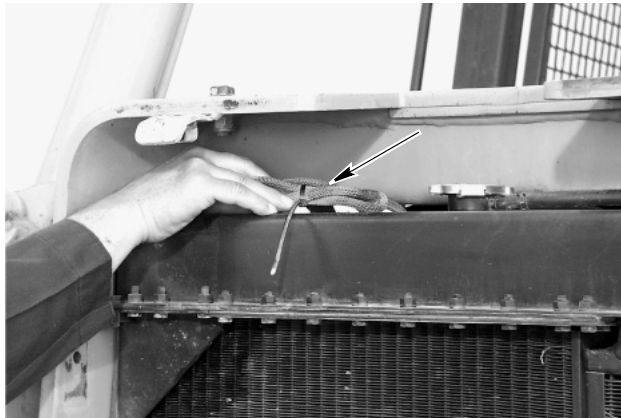

BD00H105

Push the horn wires into the engine compartment.

**STEP 25**



BD00H068

Remove the four bolts securing the braces (30) to the radiator shroud. Remove the braces as an assembly.

**STEP 26**

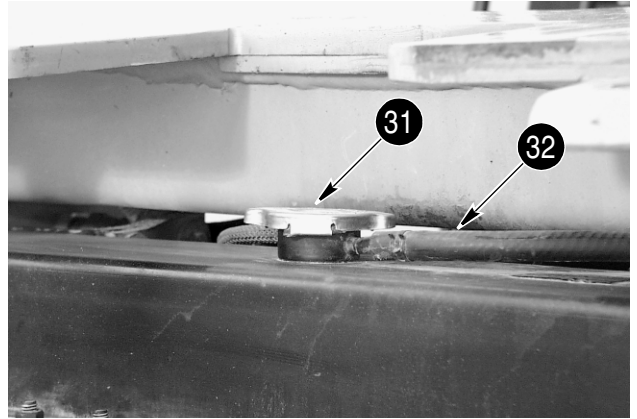

BD00H069

Make sure the engine is cool and remove the radiator cap (31). Disconnect and plug the coolant recovery hose (32).

**STEP 27**

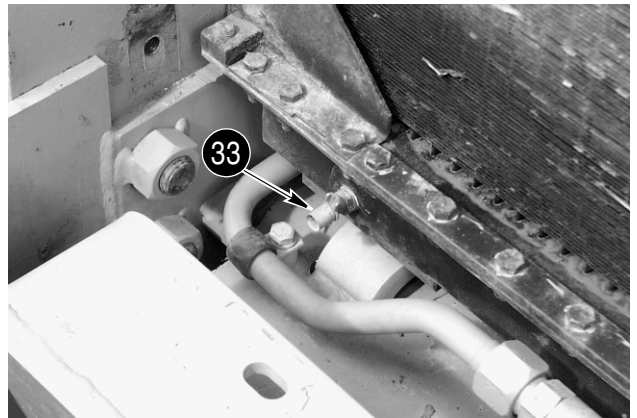

BD00H070

Connect a drain hose to the drain valve (33). Place the other end of the hose in a clean six gallon container. Open the drain valve and drain the coolant.

**STEP 28**

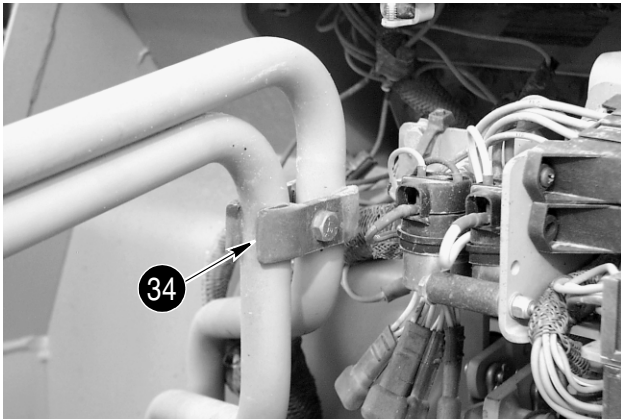

BD00H026



BD00H025

Remove the two clamps (34) securing the two tube assemblies for the lift cylinders.

**STEP 29**

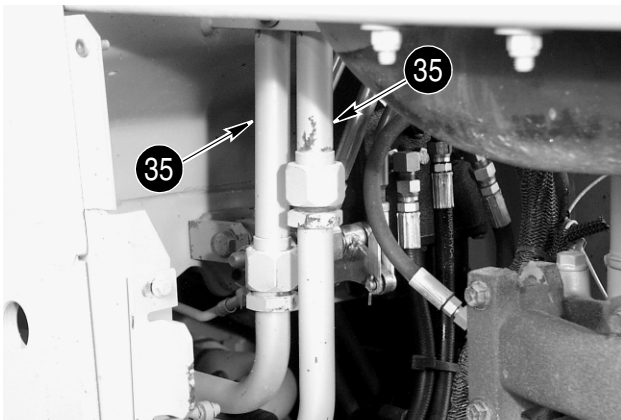

BD00H023

Loosen and disconnect the two tube assemblies (35) for the lift cylinders at the connection behind the engine. Plug and cap the tube assemblies fittings to prevent entry of foreign matter.

**STEP 30**

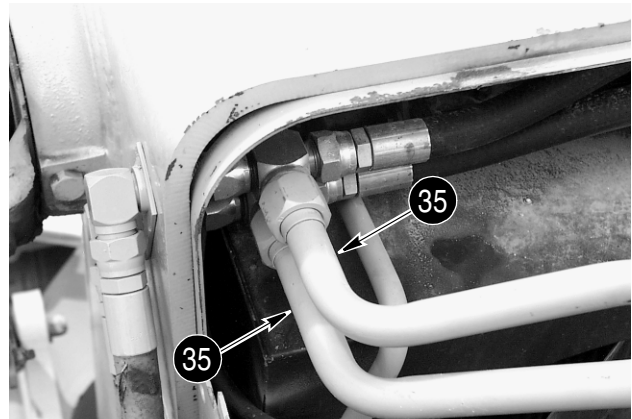

BD00H028

Loosen and disconnect the two tube assemblies (35) for the lift cylinders at the connection above the oil cooler. Plug and cap the tube assemblies fittings to prevent entry of foreign matter. Remove the tube assemblies.

**STEP 31**

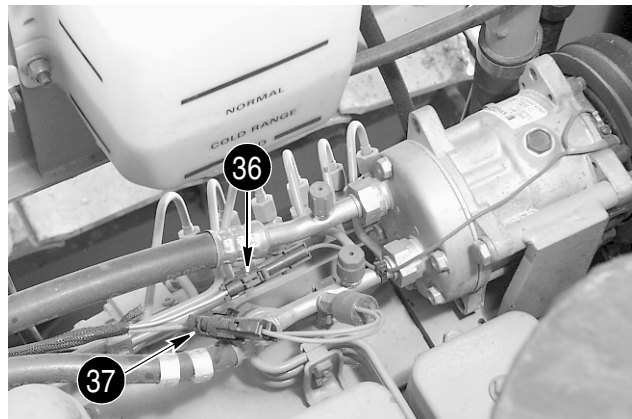

BD00F170



BD00F183

If equipped with air conditioning, disconnect air compressor clutch connector (36) and high pressure switch connector (37) from wiring harness connectors. Cut, remove, and discard tie strap (38) holding air conditioning hoses and wiring harness to engine rear lifting bracket.

**STEP 32**

If equipped with air conditioning, DO NOT disconnect hoses from air compressor. Remove compressor from engine and set out of the way on the tracks. Move the air compressor hoses away from the engine.

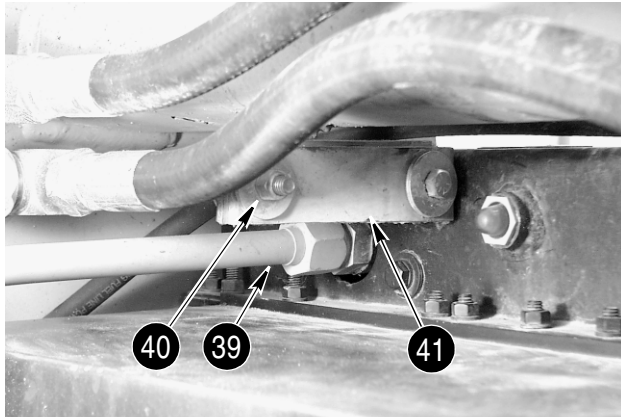
**STEP 33**

BD00H076

Disconnect the oil cooler inlet tube assembly (39) fitting from the inlet of the transmission oil cooler. Plug the tube assembly fitting and cap the oil cooler inlet to prevent entry of foreign matter. Remove the two lock nuts (40), bolts, and four washers securing the mounting straps (41) to the lugs on both sides of the radiator shroud.

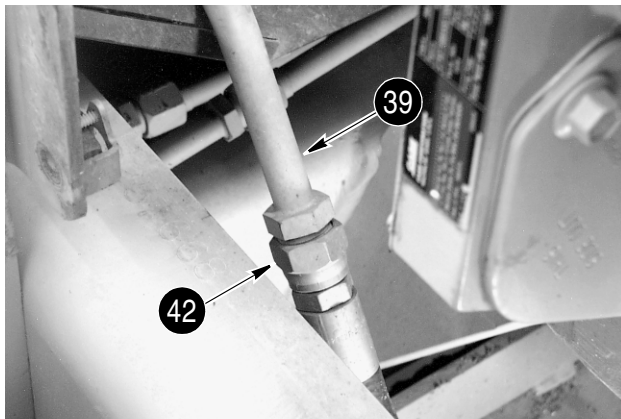
**STEP 34**

BD00H078

Disconnect hose fitting (42) from oil cooler inlet tube assembly (39). Cap tube assembly fitting and plug hose to prevent entry of foreign matter.

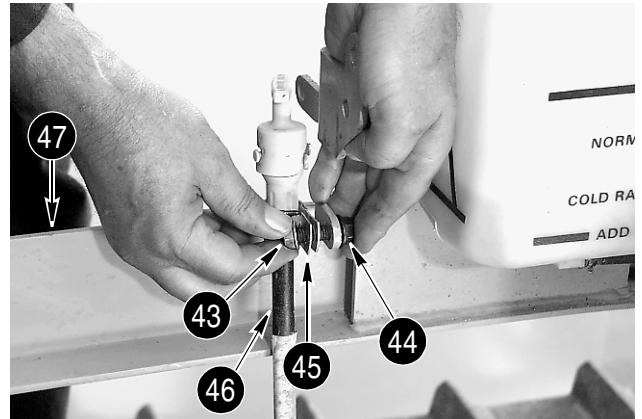
**STEP 35**

BD00J023

Remove the nut (43), bolt (44), and clamp (45) securing the oil dipstick tube (46) to the LH support panel (47). If necessary, use wire to secure the oil dipstick tube out of the way on the engine.

**STEP 36**

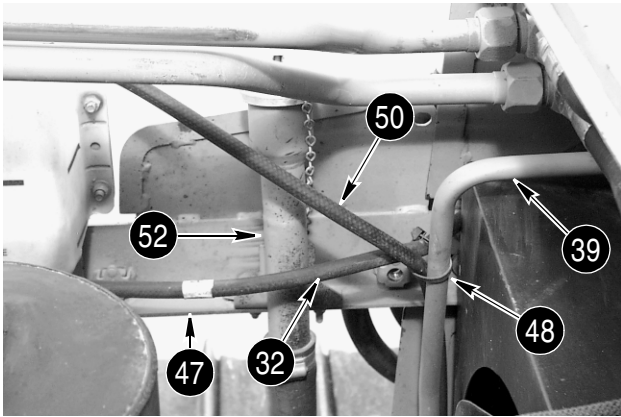

BD00H051

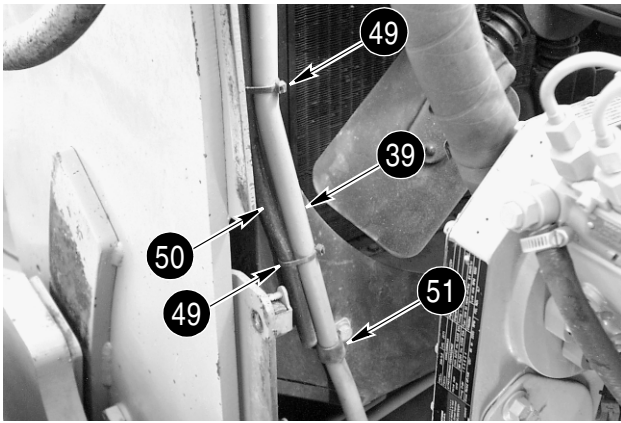

BD00H077

Cut, remove and discard tie strap (48) holding coolant reservoir hoses (32 and 50) to oil cooler inlet tube assembly (39). Cut, remove, and discard two tie straps (49) holding coolant reservoir overflow hose (50) to oil cooler inlet tube assembly. Remove clamp (51) then remove oil cooler inlet tube assembly (39). Remove two bolts and lock nuts securing oil filler tube (52) to LH support panel (47). Remove two bolts and spacers securing front of support panel and two bolts and lock nuts securing rear of support panel. Remove support panel with installed coolant reservoir as an assembly from machine.

**STEP 37**

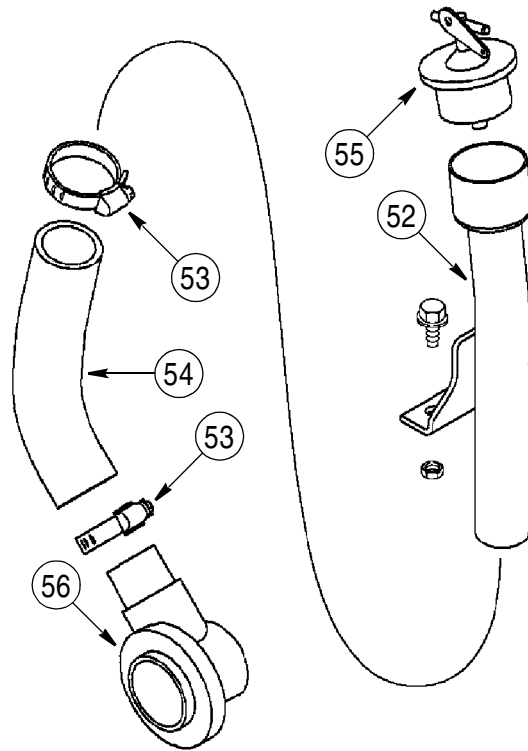

BS00H074

Loosen clamp (53) at bottom of oil filler tube hose (54). Pull hose and oil filler tube (52) with cap (55) from connector (56) installed in engine front cover. Plug connector to prevent entry of foreign matter.

**STEP 38**



BD00H108

Connect suitable lifting equipment to the radiator shroud and lift cylinder assemblies.

**STEP 39**

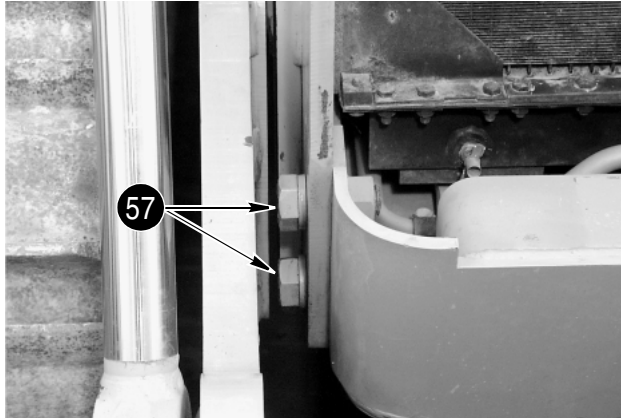

BD00H106

Remove the two front bolts (57) and washers on each side of the radiator shroud.

**STEP 40**

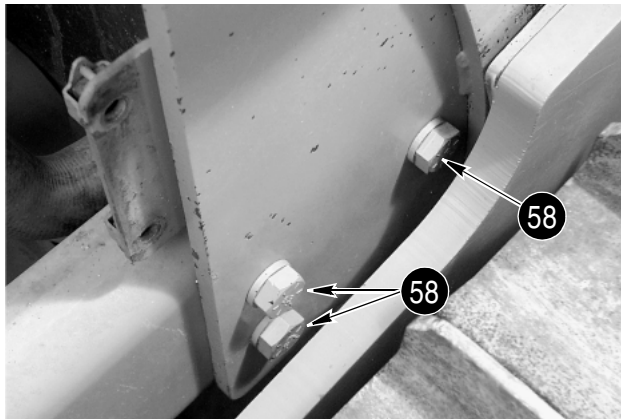

BD00H107

Remove the three rear bolts (58) and washers on each side of the radiator shroud.

**STEP 41**

Raise the radiator shroud straight up until the shroud is clear of the radiator and main frame. Set the radiator shroud down on the ground away from the machine.

**STEP 42**

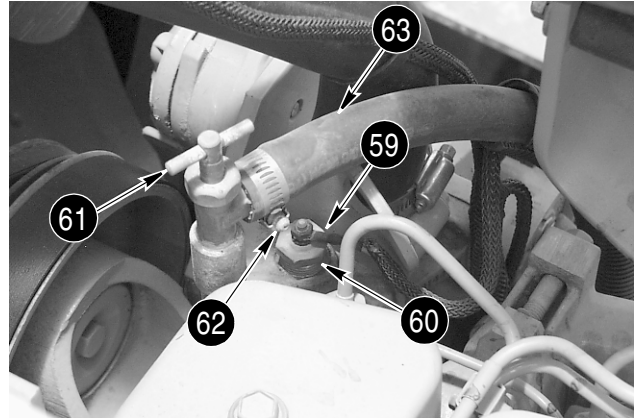

BD00F184

Tag and disconnect the wiring harness wire (59) from the coolant temperature sender (60). If machine is equipped with a heater, close heater shutoff valve (61) and loosen clamp (62). Disconnect heater hose (63) from shutoff valve and plug hose to prevent loss of coolant.

**STEP 43**

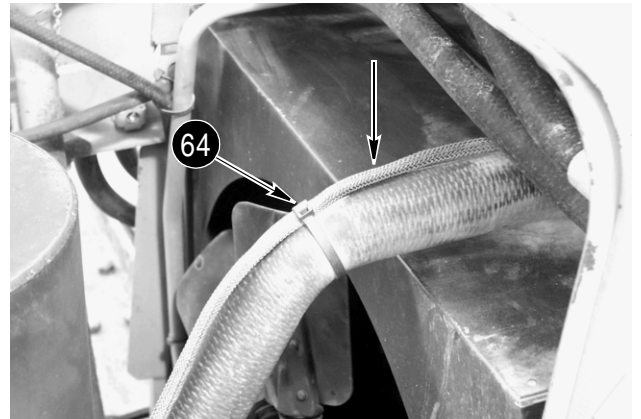

BD00H053

Cut, remove, and discard the tie strap (64). Pull the horn wires away from the upper radiator hose.

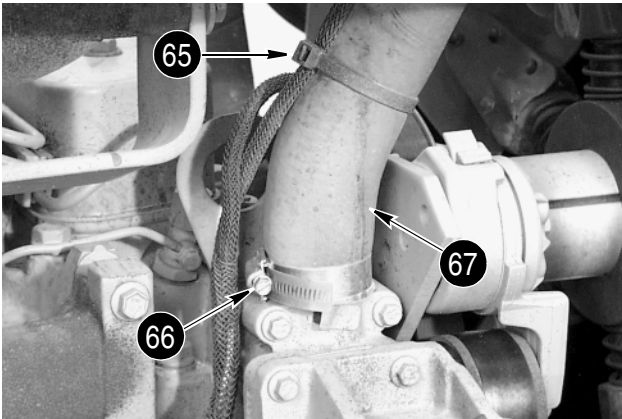
**STEP 44**

BD00H017

Cut, remove, and discard the tie strap (65). Pull the horn wires away from the upper radiator hose (67). Loosen the clamps (66) on both ends of the upper radiator hose (67). Remove the hose and clamps.

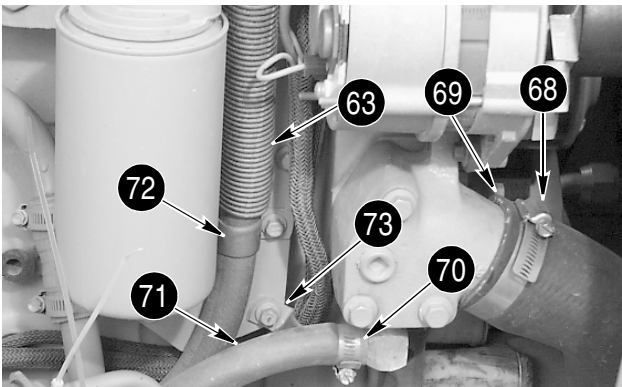
**STEP 45**

BD00F161

Loosen clamps (68) on both ends of lower radiator hose (69). Remove hose and clamps. If machine is equipped with a heater, loosen clamp (70) and disconnect heater hose (71). Install a plug in hose to prevent loss of coolant. Remove clamp (72) holding heater hose (63). Pull heater hose away from cylinder block to gain access to wires connected to alternator. Remove clamp (73) holding wiring harness to cylinder block.

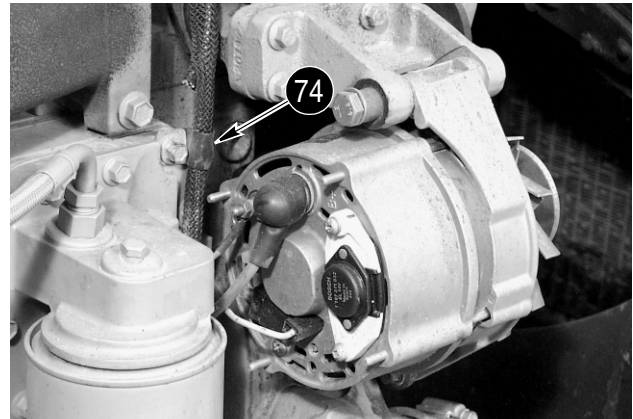
**STEP 46**

BD00H018

Tag and disconnect the wires connected to the alternator. Remove the bolt securing the clamp (74). Remove the clamp.

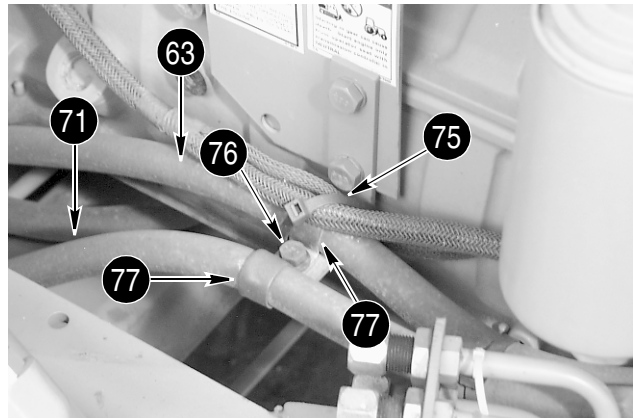
**STEP 47**

BD00F164

If machine is equipped with a heater, cut, remove and discard the tie strap (75) securing the wiring harness to the heater hose (63). Remove bolt (76), nut, and washer securing the two clamps (77). Remove the clamps. Pull the heater hoses (63 and 71) (if equipped) away from the engine. If machine is not equipped with a heater, remove the bolt securing the clamp. Remove the clamp. Pull the wiring harness down from between the alternator and engine cylinder block and through the space between the cylinder block and the turbocharger oil return line.

**STEP 48**



BD00H022

Tag and disconnect the battery cable(s) and wiring harness wires from the starter. Remove the bolt securing the clamp (78) and the battery cable to the starter. Move the battery cable(s) out of the way.

**STEP 49**

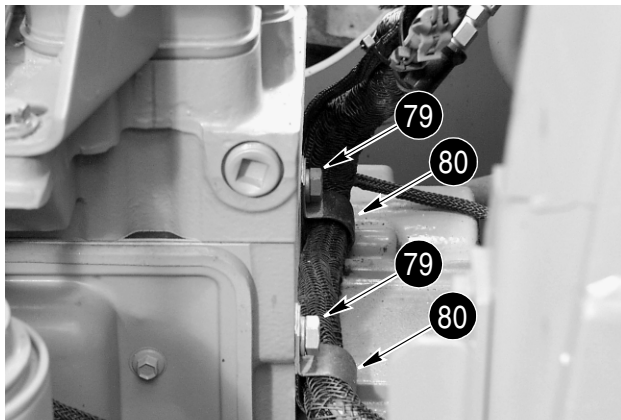

BD00H038

Remove the bolts (79) securing the two clamps (80). Remove the clamps. Pull the wiring harness branch on the RH side of the engine up between the starter and the cylinder block and move out of the way.

**NOTE:** *If your machine is equipped with ether start, do Step 50 otherwise go to Step 51.*

**STEP 50**

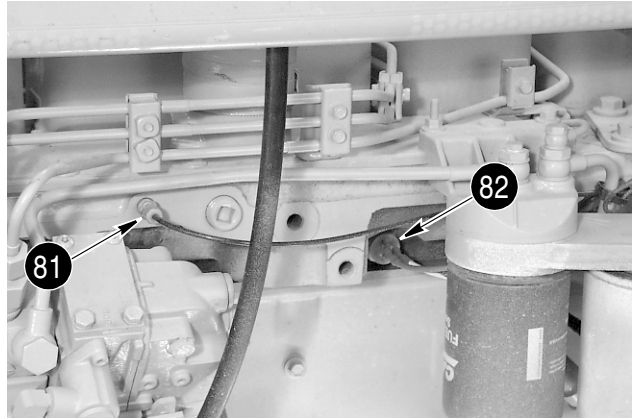

BD00F181

If equipped with ether start, disconnect ether start tube (81) from nozzle. Tag and disconnect two wires connected to ether start temperature switch (82).

**STEP 51**

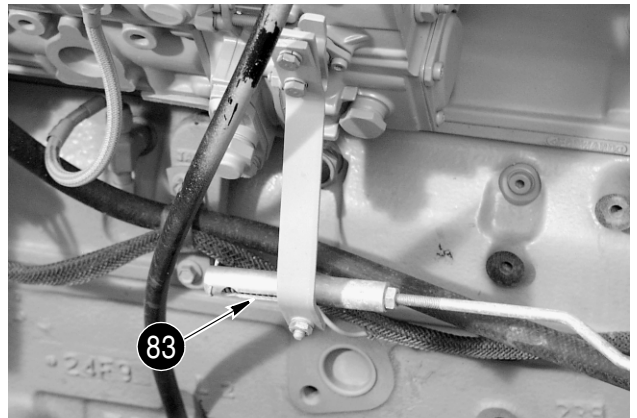

BD00H029

Remove nut and washer securing control rod (83) to fuel injection pump lever.

**STEP 52**

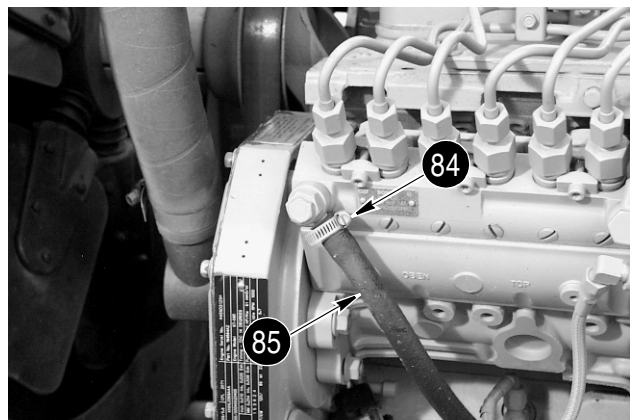

BD00H030

Loosen clamp (84) and disconnect fuel return hose (85) from fuel injection pump. Plug fuel return hose and cap fitting on fuel injection pump to prevent entry of foreign matter.

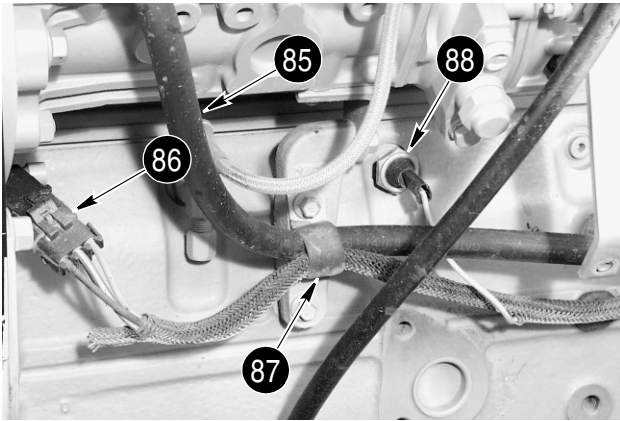
**STEP 53**

BD00H033

Disconnect fuel injection pump connector (86) from wiring harness connector. Remove bolt securing clamp (87). Remove clamp. Tag and disconnect wiring harness wire from engine oil pressure switch (88). Move fuel return hose (85) and wiring harness away from engine.

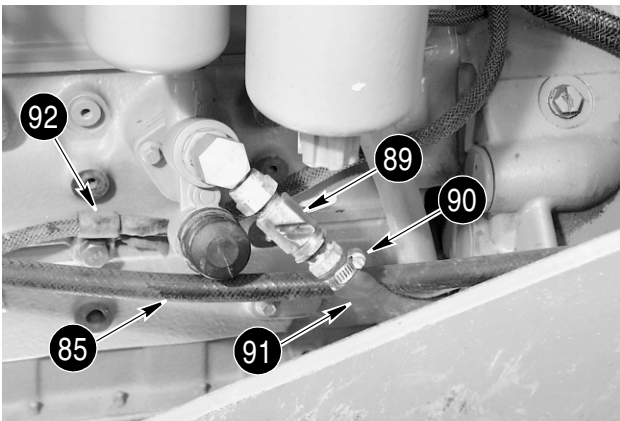
**STEP 54**

BD00H037

Close fuel shutoff valve (89). Loosen clamp (90) and disconnect fuel supply hose (91). Install a plug in fuel supply hose and a cap on the fitting. Remove bolt securing clamp (92). Remove clamp. Carefully pull the wiring harness towards the rear of the engine compartment and away from the engine. Move the fuel supply hose (91) and fuel return hose (85) away from the engine.

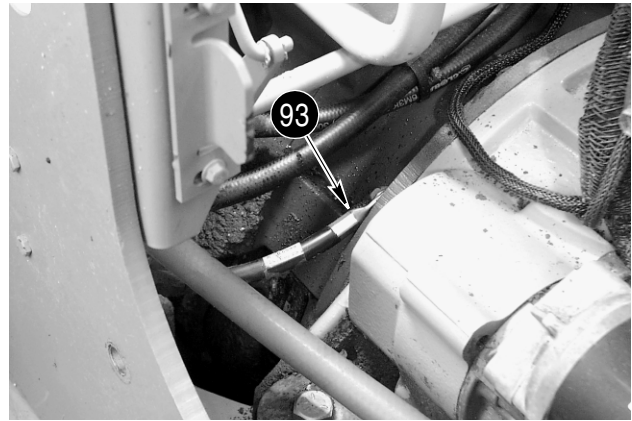
**STEP 55**

BD00H054

Disconnect ground cable (93) from rear of torque converter housing.

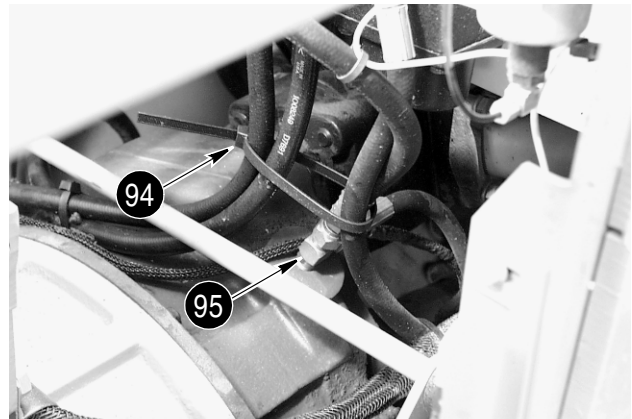
**STEP 56**

BD00H039

Cut, remove, and discard tie strap (94). Identify, tag, and disconnect two hoses connected to tee (95) installed in torque converter. Remove tee. Plug hoses and torque converter port to prevent entry of foreign matter.

**STEP 57**

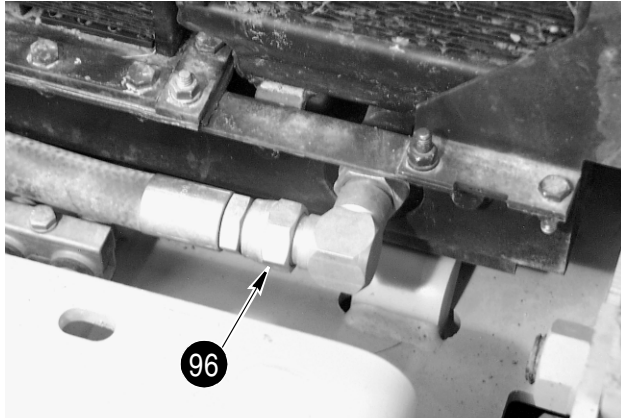

BD00H071

Put a drain pan under the hose (96) to catch oil that will drain when the hose is disconnected. Disconnect the hose from the outlet of the oil cooler. Plug the hose and cap the fitting in the oil cooler.

**STEP 58**

Connect suitable lifting equipment to the radiator.

**STEP 59**



BD00H081

Remove the two bolts and four washers from the bottom of the radiator.

**STEP 60**

Remove the radiator and place on the ground away from the machine.

**STEP 61**

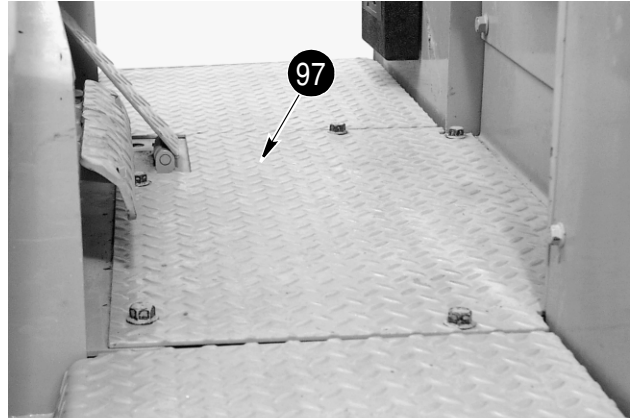

BD00H043

Remove the floor plate (97).

**STEP 62**

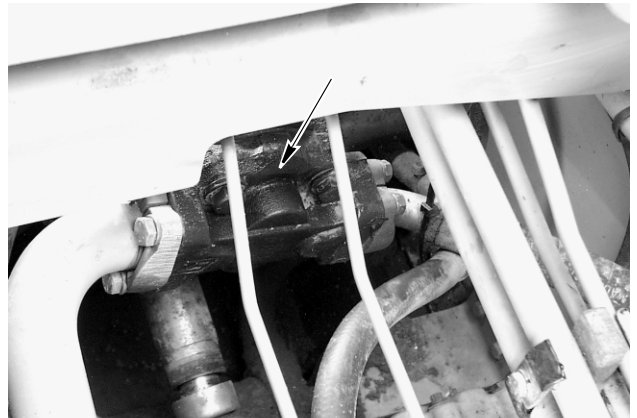

BD00H044

Connect a sling around the equipment pump and the crawler frame to support the pump and hydraulic lines when the torque converter is removed with the engine. Remove the four lock nuts and washers securing the pump to the torque converter.

**STEP 63**

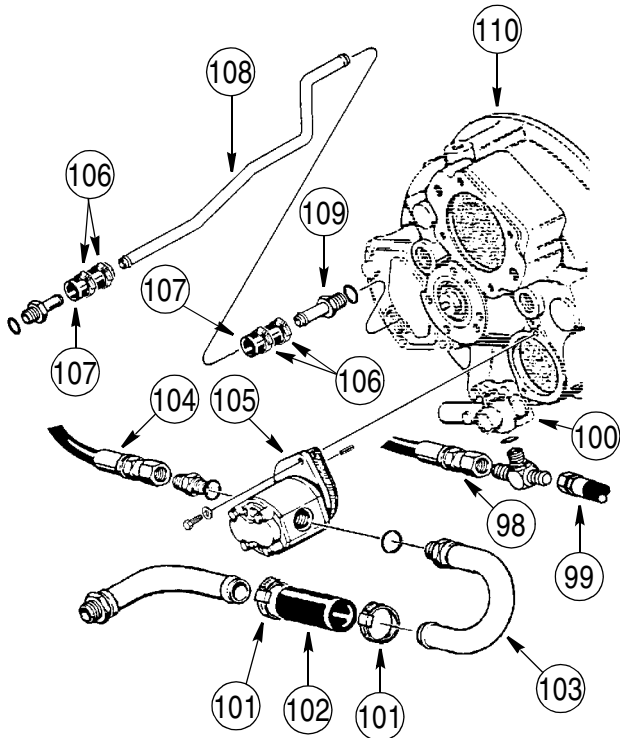

BS00H094

Identify, tag, and disconnect two hoses (98 and 99) from tee installed in inlet of pressure regulator valve (100). Loosen the two clamps (101) on the hose (102) connected to the tube (103). Loosen the fitting on the tube (103) and disconnect the tube from charge pump (105). Disconnect the oil filter hose (104) from the charge pump. Loosen the four clamps (106) on the two hoses (107) connected to the drain tube (108). Disconnect the hose from the fitting (109) in the torque converter (110). Plug and cap all hoses and fittings to prevent entry of foreign matter.

**STEP 64**

Remove the bolts securing the drive shaft to the output shaft of the torque converter. Use a piece of wire to hold the drive shaft out of the way.

**STEP 65**

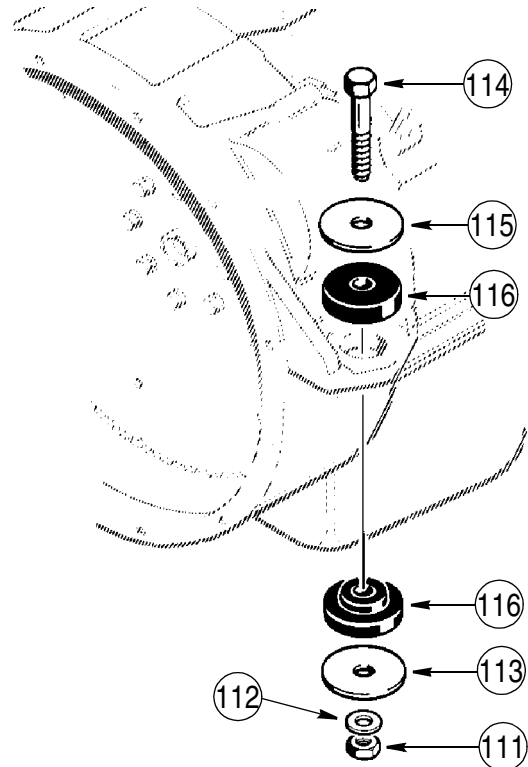

BS00E121

Remove nut (111), washers (112 and 113), bolt (114), and washer (115) from mounting flange on each side of the flywheel housing.

**STEP 66**

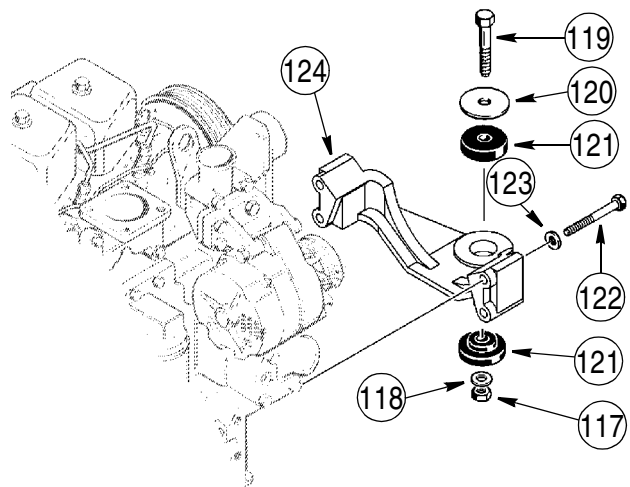

BS00E122

Remove nut (117), washer (118), bolt (119), and washer (120) from engine front support (124).

**STEP 67**

Connect suitable lifting equipment to lifting eyes on engine. Raise engine slightly. Check to ensure that all hoses, lines, and wiring have been disconnected and are out of the way. If necessary, disconnect any hoses, lines, or wiring that has not been disconnected. Move engine forward until engine and torque converter clear accelerator control rod and hoses connected to brake valve then raise engine and remove from machine.

**STEP 68**

Remove engine mounts (116 and 121) from mounting flanges on each side of flywheel housing and engine front support (124).

**STEP 69**

If engine front support (124) requires removal, connect suitable lifting equipment to front support. Remove four bolts (122) and washers (123). Remove front support from engine.

**STEP 70**

Refer to Section 6000 to remove the torque converter from the engine.

## Installation

### STEP 71

Refer to Section 6000 to install the torque converter on the engine.

### STEP 72

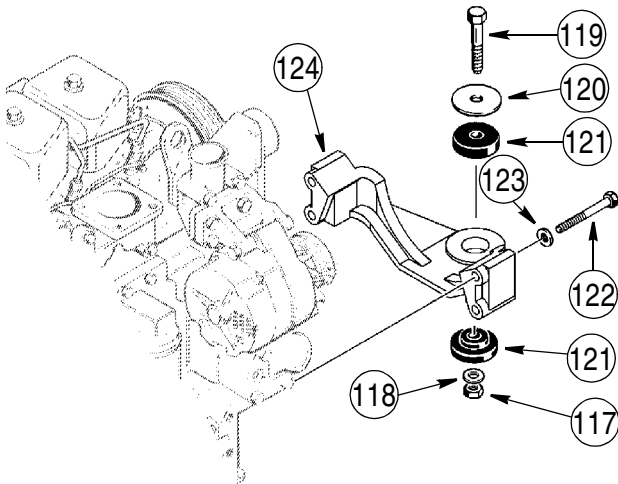

BS00E122

If engine front support (124) was removed, connect suitable lifting equipment to front support and move into position at front of engine. Install four bolts (122) and washers (123). Tighten bolts to a torque of 125 to 156 Nm (92 to 115 lb-ft).

### STEP 73

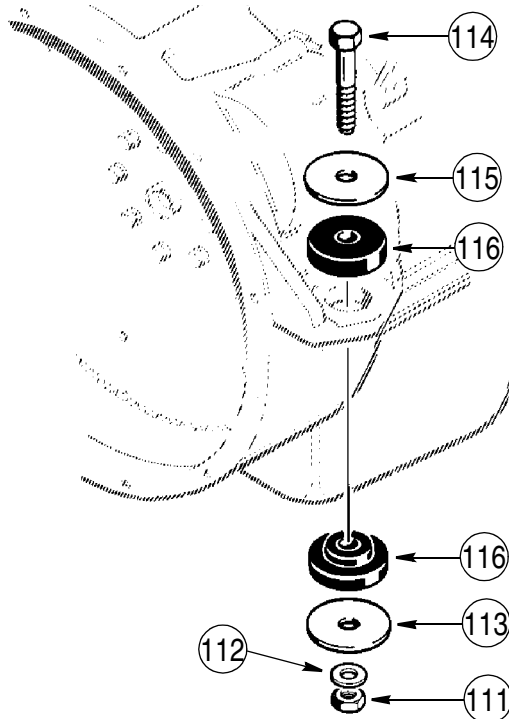

BS00E121

Install engine mounts (116 and 121) in mounting flanges on each side of flywheel housing and engine front support (124).

### STEP 74

Connect suitable lifting equipment to lifting eyes on engine. Raise engine and move into position on machine. Carefully lower engine and guide into position in machine.

### STEP 75

Install washer (120), bolt (119), washer (118), and nut (117).

### STEP 76

Install washer (115), bolt (114), washers (113 and 112), and nut (111) in mounting flange on each side of the flywheel housing.

### STEP 77

Tighten bolt (119) to a torque of 205 to 230 Nm (151 to 170 lb-ft), then tighten bolts (114) to same torque. Disconnect lifting equipment from engine lifting eyes.

### STEP 78

Remove wire holding drive shaft out of the way. Position universal joint on output shaft of torque converter and install bolts. Tighten bolts to a torque of 50 to 66 Nm (37 to 49 lb-ft).

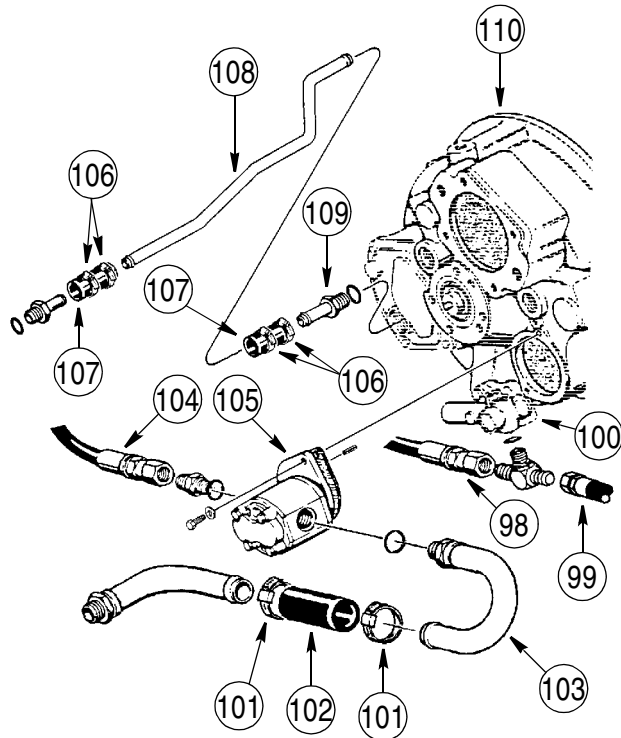
**STEP 79**

BS00H094

Remove plugs and caps from hoses and fittings. Connect hose (107) connected to drain tube (108) to adapter (109) installed in torque converter (110). If necessary, adjust position of drain tube (108) in hoses (107). Tighten clamps (106). Connect oil filter hose (104) to charge pump (105). Remove and discard the O-ring on tube (103) and install a new O-ring. Connect tube (103) fitting to charge pump port and tighten fitting. Tighten the two clamps (101) on hose (102). Connect the two hoses (98 and 99) to the tee installed in pressure regulator valve (100) inlet following tags installed during removal. Remove and discard tags.

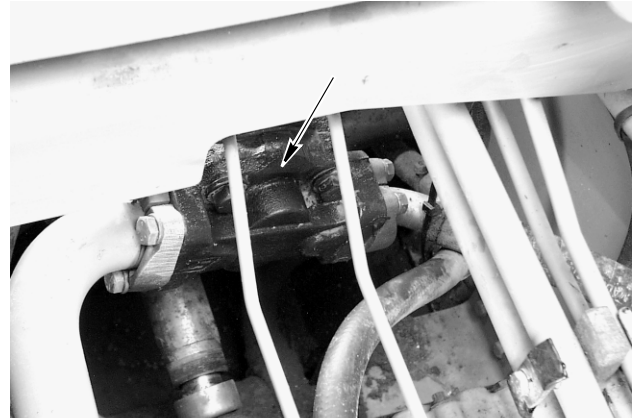
**STEP 80**

BD00H044

Install the equipment pump shaft in the drive coupling in the torque converter. Install four washers and lock nuts to secure the equipment pump. Remove the sling used to support the pump while the torque converter was removed.

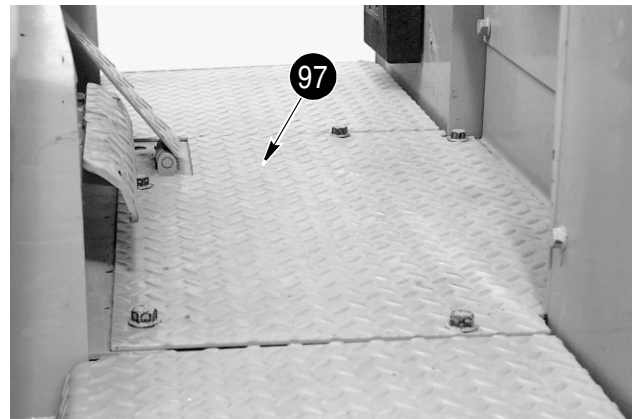
**STEP 81**

BD00H043

Install the floor plate (97).

**STEP 82**

Connect suitable lifting equipment to the radiator. Raise the radiator and move into position on the machine on the radiator mounts.



**Suggest:**

**If the above button click is invalid.**

**Please download this document**

**first, and then click the above link**

**to download the complete manual.**

**Thank you so much for reading**

### STEP 83



BD00H081

Install the four washers and two bolts in the bottom of the radiator. Tighten the bolts to a torque of 68 to 81 Nm (50 to 60 lb-ft).

### STEP 84

Disconnect the lifting equipment from the radiator.

### STEP 85

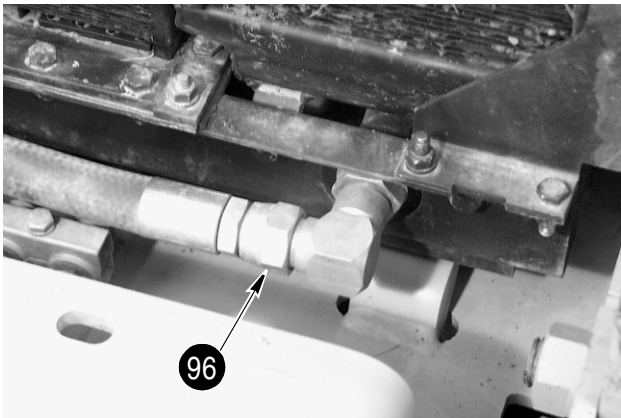

BD00H071

Remove the plug from the hose (96) and the cap from the fitting. Connect the hose to the outlet of the oil cooler.

### STEP 86

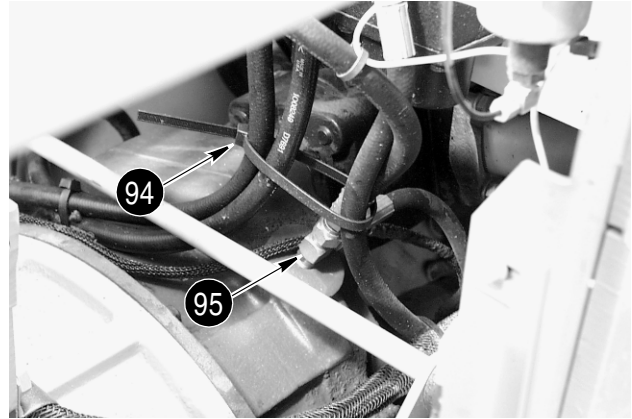

BD00H039

Remove the plug from the torque converter port. Install tee (95) in the port. Remove the plugs from the hoses and connect hoses to tee following tags installed during removal. Remove and discard tags. Install a new tie strap (94) to secure hoses.

### STEP 87

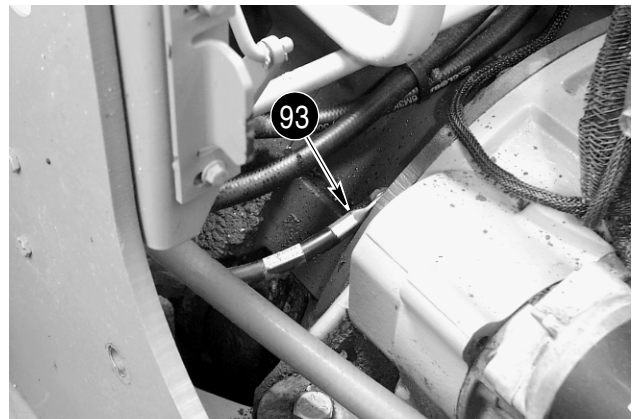

BD00H054

Connect the ground cable (93) to the rear of the torque converter housing. Tighten the bolt to a torque of 21 to 27 Nm (15 to 20 lb-ft).

**<https://www.ebooklibonline.com>**

Hello dear friend!

Thank you very much for reading.

Enter the link into your browser.

The full manual is available for immediate download.

**<https://www.ebooklibonline.com>**