

# 1150D/1155D CRAWLERS TABLE OF CONTENTS

| SERIES/SECTION  | SECTION NO. | FORM NO. |
|---|-------------|----------|
| <b>1 GENERAL</b>  |             |          |
| Safety Rules, Service Manual Introduction, and<br>Torque Specifications .....   | 1001        | 8-41280  |
| Maintenance and Lubrication .....   | 1002        | 8-41280  |
| General Engine Specifications .....   | 1010        | 8-25220  |
| Detailed Engine Specifications .....  | 1320        | 8-20040  |
| <b>2 ENGINE</b>   |             |          |
| Engine Stall Tests, Engine Removal and Installation,<br>Engine Accessories (Radiator, Air Cleaner, Mufflers,<br>Ether Injection System, Turbocharger) ..... | 2000        | 8-41280  |
| Engine Tune-Up .....  | 2002        | 9-76379  |
| Cylinder Head, Valve Train, and Camshaft .....  | 2015        | 8-22560  |
| Cylinder Block, Sleeves, Pistons, and Rods .....  | 2025        | 9-76176  |
| Crankshaft, Main Bearings, Flywheel, and Oil Seals .....  | 2035        | 9-76187  |
| Lubrication System .....  | 2046        | 8-22780  |
| Cooling System .....  | 2055        | 9-76337  |
| Engine Troubleshooting .....  | 2201        | 8-20110  |
| Reconditioning the Engine Block .....   | 2290        | 8-21170  |
| Turbocharger Failure Analysis .....   | 2565        | 9-78235  |
| <b>3 FUEL SYSTEM</b>  |             |          |
| Fuel Tank, Fuel Lines, and Engine Controls .....  | 3001        | 8-41280  |
| Fuel System and Filters .....   | 3010        | 9-75297  |
| Robert Bosch Fuel Injection Pump .....  | 3012        | 9-74937  |
| 17 mm Fuel Injectors .....  | 3213        | 8-20240  |
| <b>4 ELECTRICAL</b>   |             |          |
| Electrical System Specifications and Troubleshooting .....  | 4002        | 8-41280  |
| Wiring Diagrams .....   | 4003        | 8-41280  |
| Gauges .....  | 4004        | 8-41280  |
| Batteries .....   | 4005        | 8-41280  |
| Starter and Starter Solenoid .....  | 4006        | 8-41280  |
| Alternator .....  | 4007        | 8-41280  |
| <b>5 TRACK AND SUSPENSION</b>   |             |          |
| Case Lubricated Track .....   | 5504        | 8-42190  |
| Track, Track Frame, and Suspension .....  | 5506        | 8-41280  |
| Idler, Track Adjuster, and Recoil Housing .....   | 5508        | 8-41280  |
| Sprockets .....   | 5509        | 8-41280  |
| Carrier Rollers .....   | 5510        | 8-41280  |
| Track Rollers .....   | 5511        | 8-41280  |

| SERIES/SECTION   | SECTION NO. | FORM NO. |
|--|-------------|----------|
| <b>6 POWER TRAIN</b>   |             |          |
| Transmission Maintenance and Troubleshooting .....   | 6002        | 8-41280  |
| Transmission Diagrams and Operation .....  | 6003        | 8-41280  |
| Charging Pump .....  | 6005        | 9-67861  |
| Transmission Control Valve .....   | 6007        | 8-41280  |
| Torque Converter .....   | 6010        | 8-41280  |
| Transmission .....   | 6016        | 8-41280  |
| Final Drives .....   | 6017        | 8-41280  |
| Transmission Controls .....  | 6018        | 8-41280  |
| Drive Shaft .....  | 6021        | 8-41280  |
| <b>7 BRAKES</b>  |             |          |
| Brakes .....   | 7001        | 8-41280  |
| <b>8 HYDRAULICS</b>  |             |          |
| Hydraulic System Specifications, Diagrams, Maintenance<br>Troubleshooting, and Pressure Checks ..... | 8002        | 8-41280  |
| Cleaning the Hydraulic System .....  | 8003        | 8-41280  |
| Pump .....   | 8005        | 8-41280  |
| Equipment Control Valve .....  | 8007        | 8-41280  |
| Selector Valve .....   | 8021        | 8-41280  |
| Cylinders .....  | 8090        | 8-41280  |
| <b>9 MOUNTED EQUIPMENT</b>   |             |          |
| Air Conditioning Troubleshooting .....   | 9002        | 8-41280  |
| Air Conditioning System .....  | 9003        | 8-41280  |
| Loader .....   | 9010        | 8-41280  |
| Dozer Blade .....  | 9020        | 8-41280  |
| Ripper .....   | 9031        | 8-41280  |
| Cab and Canopy .....   | 9061        | 8-41280  |
| Operators Seats and Seat Belts .....   | 9064        | 8-41280  |
| Decals, Painting, and Noise Control .....  | 9201        | 8-41280  |
| Winch .....  | 9300        | 8-41280  |

# 1001

## SAFETY RULES SERVICE MANUAL INTRODUCTION AND TORQUE SPECIFICATIONS

### TABLE OF CONTENTS

|  |        |   |        |
|--|--------|---|--------|
| <b>Safety Rules</b> .....                | 1001-2 | Illustrations and Photos .....  | 1001-4 |
| <b>Service Manual Introduction</b> ..... | 1001-4 | Clear and Simple English .....  | 1001-4 |
| Right, Left, Front, and Rear .....       | 1001-4 | Special Tools .....   | 1001-4 |
| Text .....                               | 1001-4 | <b>Product Identification Number<br/>(PIN) and Serial Numbers</b> ..... | 1001-5 |
| Table of Contents .....                  | 1001-4 | <b>Torque Specifications</b> .....                                      | 1001-6 |
| Page Numbers .....                       | 1001-4 |   |        |

Written In *Clear  
And  
Simple  
English*

**<https://www.ebooklibonline.com>**

Hello dear friend!

Thank you very much for reading.

Enter the link into your browser.

The full manual is available for immediate download.

**<https://www.ebooklibonline.com>**

## SERVICE MANUAL INTRODUCTION

This service manual has been prepared with the latest service information available. Troubleshooting, removal, disassembly, inspection and installation procedures, and complete specifications and tightening references can be found in most sections. Some sections have drawings but no written procedure because the job is so easily done. This service manual is one of the most important tools available to the service technician.

### Right, Left, Front, and Rear

The terms right-hand and left-hand and front and rear as used in this manual indicate the right and left sides, and front and rear of the machine as seen from the operator's seat for correct operation of the machine or attachment.

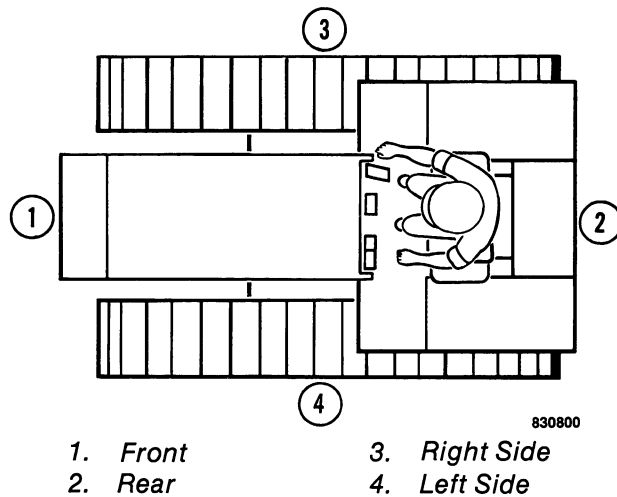

### Text

If the service manual is for more than one machine or different models of components (planetary axles, gear boxes, control valves, etc.) the procedures have the steps necessary to service each model.

### Table of Contents

A Table of Contents is in the front of this manual. The Table of Contents shows the main divisions and the sections that are in each division. The individual sections, where necessary, have a Table of Contents on the cover or second page of that section.

### Page Numbers

All page numbers are made of two numbers separated by a dash, such as 4002-9. The number before the dash is the section number. The number following the dash is the page number in that section. Page numbers will be found at the upper right or left of each page.

### Illustrations and Photos

Illustrations are put as near as possible to the text and are to be used as part of the text. Photos normally are put below the step to which they apply.

### Clear and Simple English

This manual is written in C.A.S.E. (Clear and Simple English). C.A.S.E. is easier to read and understand than "regular" English because C.A.S.E. uses a small number of common words and has special rules for writing.

All sections written in C.A.S.E. are indicated by the symbol below.

Written In *Clear  
And  
Simple  
English*

### Special Tools

Special tools are needed to remove and install, disassemble and assemble, check, and adjust some component parts of this machine. Some special tools can be easily made locally and the necessary information to make the tool is in this service manual. Other special tools are more difficult to make locally and are available from Service Tools in the U.S. and from Jobborn Manufacturing in Canada. Use these tools according to the instructions in this service manual for your personal safety and to do the job correctly.

Order special tools from either of the following companies:

Service Tools  
P.O. Box 314  
Owatonna, Minnesota 55060

Jobborn Manufacturing Co.  
97 Frid Street  
Hamilton, Ontario L8P 4M3  
Canada

# PRODUCT IDENTIFICATION NUMBER (PIN) AND SERIAL NUMBERS

**NOTE:** A serial number plate is also on some components such as the starter, alternator, pump, etc.

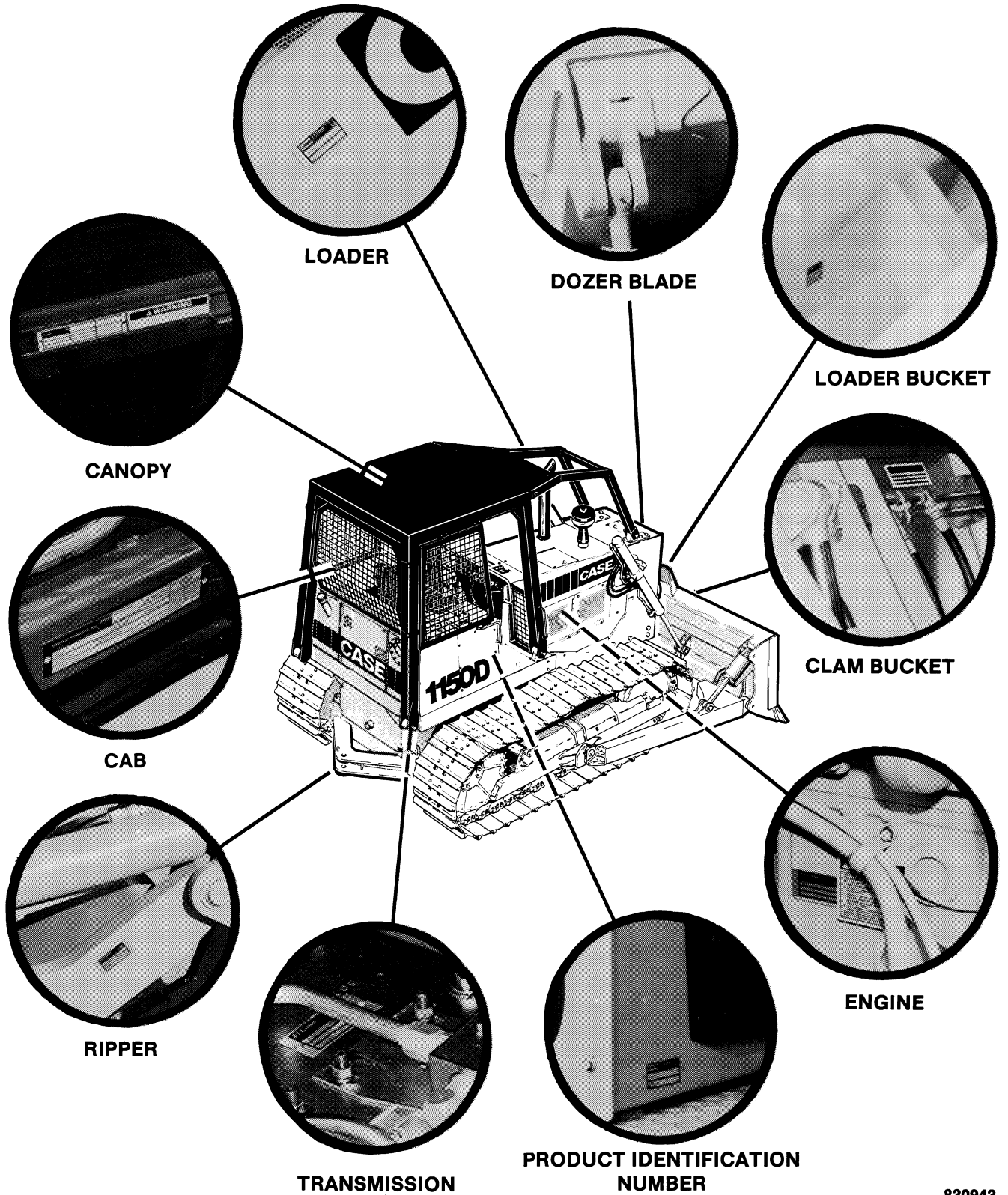

## TORQUE SPECIFICATIONS - U.S. HARDWARE

Use the torques in this chart when special torques are not given. These torques apply to fasteners with both UNC and UNF threads as received from suppliers, dry, or when lubricated with engine oil. Not applicable if special graphites, moly-disulfide greases, or other extreme pressure lubricants are used.

| <b>Grade 5 Bolts, Nuts, and Studs</b>   |            |               |                 |
|---|------------|---------------|-----------------|
|  |            |               |                 |
| Size  | Pound-Feet | Newton metres | Kilogram metres |
| <b>1/4 in</b><br>6.4 mm   | 9-11       | 12-15         | 1.2-1.5         |
| <b>5/16 in</b><br>7.9 mm  | 17-21      | 23-28         | 2.4-2.9         |
| <b>3/8 in</b><br>9.5 mm   | 35-42      | 48-57         | 4.8-5.8         |
| <b>7/16 in</b><br>11.1 mm   | 54-64      | 73-87         | 7.5-8.8         |
| <b>1/2 in</b><br>12.7 mm  | 80-96      | 109-130       | 11.1-13.3       |
| <b>9/16 in</b><br>14.3 mm   | 110-132    | 149-179       | 15.2-18.2       |
| <b>5/8 in</b><br>15.9 mm  | 150-180    | 203-244       | 20.8-24.9       |
| <b>3/4 in</b><br>19.0 mm  | 270-324    | 366-439       | 37.3-44.8       |
| <b>7/8 in</b><br>22.2 mm  | 400-480    | 542-651       | 55.3-66.4       |
| <b>1.0 in</b><br>25.4 mm  | 580-696    | 787-944       | 80.2-96.2       |
| <b>1-1/8 in</b><br>28.6 mm  | 800-880    | 1085-1193     | 111-122         |
| <b>1-1/4 in</b><br>31.8 mm  | 1120-1240  | 1519-1681     | 155-171         |
| <b>1-3/8 in</b><br>34.9 mm  | 1460-1680  | 1980-2278     | 202-232         |
| <b>1-1/2 in</b><br>38.1 mm  | 1940-2200  | 2631-2983     | 268-304         |

| <b>Grade 8 Bolts, Nuts, and Studs</b>  |            |               |                 |
|--|------------|---------------|-----------------|
|  |            |               |                 |
| Size   | Pound-Feet | Newton metres | Kilogram metres |
| <b>1/4 in</b><br>6.4 mm  | 12-15      | 16-20         | 1.7-2.1         |
| <b>5/16 in</b><br>7.9 mm   | 24-29      | 33-39         | 3.3-4.0         |
| <b>3/8 in</b><br>9.5 mm  | 45-54      | 61-73         | 6.2-7.5         |
| <b>7/16 in</b><br>11.1 mm  | 70-84      | 95-114        | 9.7-11.6        |
| <b>1/2 in</b><br>12.7 mm   | 110-132    | 149-179       | 15.2-18.2       |
| <b>9/16 in</b><br>14.3 mm  | 160-192    | 217-260       | 22.1-26.5       |
| <b>5/8 in</b><br>15.9 mm   | 220-264    | 298-358       | 30.4-36.5       |
| <b>3/4 in</b><br>19.0 mm   | 380-456    | 515-618       | 52.5-63.0       |
| <b>7/8 in</b><br>22.2 mm   | 600-720    | 814-976       | 83.0-99.5       |
| <b>1.0 in</b><br>25.4 mm   | 900-1080   | 1220-1465     | 124-149         |
| <b>1-1/8 in</b><br>28.6 mm   | 1280-1440  | 1736-1953     | 177-199         |
| <b>1-1/4 in</b><br>31.8 mm   | 1820-2000  | 2468-2712     | 252-277         |
| <b>1-3/8 in</b><br>34.9 mm   | 2380-2720  | 3227-3688     | 329-376         |
| <b>1-1/2 in</b><br>38.1 mm   | 3160-3560  | 4285-4827     | 437-492         |

## TORQUE SPECIFICATIONS - STEEL HYDRAULIC FITTINGS

| Tube OD<br>Hose ID              | Thread<br>Size | Pound-<br>Feet | Newton<br>metres | Kilogram<br>metres |
|---------------------------------|----------------|----------------|------------------|--------------------|
| <b>37 Degree Flare Fittings</b> |                |                |                  |                    |
| <b>1/4 in</b><br>6.4 mm         | 7/16-20        | 6-12           | 8-16             | 0.8-1.7            |
| <b>5/16 in</b><br>7.9 mm        | 1/2-20         | 8-16           | 11-21            | 1.1-2.2            |
| <b>3/8 in</b><br>9.5 mm         | 9/16-18        | 10-25          | 14-33            | 1.4-3.5            |
| <b>1/2 in</b><br>12.7 mm        | 3/4-16         | 15-42          | 20-56            | 2.1-5.8            |
| <b>5/8 in</b><br>15.9 mm        | 7/8-14         | 25-58          | 34-78            | 3.5-8.0            |
| <b>3/4 in</b><br>19.0 mm        | 1-1/16-12      | 40-80          | 54-108           | 5.5-11.1           |
| <b>7/8 in</b><br>22.2 mm        | 1-3/16-12      | 60-100         | 81-135           | 8.3-13.9           |
| <b>1.0 in</b><br>25.4 mm        | 1-5/16-12      | 75-117         | 102-158          | 10.4-16.2          |
| <b>1-1/4 in</b><br>31.8 mm      | 1-5/8-12       | 125-165        | 169-223          | 17.3-22.8          |
| <b>1-1/2 in</b><br>38.1 mm      | 1-7/8-12       | 210-250        | 285-338          | 29.0-34.6          |

| Tube OD<br>Hose ID                  | Thread<br>Size | Pound-<br>Feet | Newton<br>metres | Kilogram<br>metres |
|-------------------------------------|----------------|----------------|------------------|--------------------|
| <b>Straight Threads with O-ring</b> |                |                |                  |                    |
| <b>1/4 in</b><br>6.4 mm             | 7/16-20        | 12-19          | 16-25            | 1.7-2.6            |
| <b>5/16 in</b><br>7.9 mm            | 1/2-20         | 16-25          | 22-33            | 2.2-3.5            |
| <b>3/8 in</b><br>9.5 mm             | 9/16-18        | 25-40          | 34-54            | 3.5-5.5            |
| <b>1/2 in</b><br>12.7 mm            | 3/4-16         | 42-67          | 57-90            | 5.8-9.3            |
| <b>5/8 in</b><br>15.9 mm            | 7/8-14         | 58-92          | 79-124           | 8.0-12.7           |
| <b>3/4 in</b><br>19.0 mm            | 1-1/16-12      | 80-128         | 108-174          | 11.1-17.8          |
| <b>7/8 in</b><br>22.2 mm            | 1-3/16-12      | 100-160        | 136-216          | 13.8-22.1          |
| <b>1.0 in</b><br>25.4 mm            | 1-5/16-12      | 117-187        | 159-253          | 16.2-25.9          |
| <b>1-1/4 in</b><br>31.8 mm          | 1-5/8-12       | 165-264        | 224-357          | 22.8-36.5          |
| <b>1-1/2 in</b><br>38.1 mm          | 1-7/8-12       | 250-400        | 339-542          | 34.6-55.3          |

| <b>Split Flange Mounting Bolts</b> |                |                  |                    |
|------------------------------------|----------------|------------------|--------------------|
| Size                               | Pound-<br>Feet | Newton<br>metres | Kilogram<br>metres |
| 5/16-18                            | 15-20          | 20-27            | 2.1-2.8            |
| 3/8-16                             | 20-25          | 26-33            | 2.8-3.5            |
| 7/16-14                            | 35-45          | 47-61            | 4.7-6.2            |
| 1/2-13                             | 55-65          | 74-88            | 7.6-9.0            |
| 5/8-11                             | 140-150        | 190-203          | 19.4-20.7          |

# 2000

## ENGINE STALL TESTS, ENGINE REMOVAL AND INSTALLATION, ENGINE ACCESSORIES

### TABLE OF CONTENTS

|   |         |                                      |         |
|---|---------|--------------------------------------|---------|
| <b>Stall Tests</b> .....  | 2000-2  | Cleaning the Primary Element .....   | 2000-47 |
| Specifications .....  | 2000-2  | Secondary Element .....              | 2000-47 |
| Procedure to Heat the Oil .....                                     | 2000-3  | Precleaner .....                     | 2000-47 |
| Torque Converter .....  | 2000-3  | Filter Fitting .....                 | 2000-47 |
| Hydraulic System .....  | 2000-3  | Checking the Filter Fitting .....    | 2000-47 |
| Test No. 1 - Torque Converter and<br>Hydraulic Stall Together ..... | 2000-3  | Restriction Indicator Check .....    | 2000-48 |
| Understanding the Results of<br>the Test .....                      | 2000-4  | <b>Spark Arrester Muffler</b> .....  | 2000-48 |
| Test No. 2 - Torque Converter Stall ....                            | 2000-4  | <b>Ether Injection System</b> .....  | 2000-50 |
| Understanding the Results of<br>the Test .....                      | 2000-4  | General Information .....            | 2000-51 |
| Test No. 3 - Hydraulic Stall .....                                  | 2000-4  | Operating Procedure .....            | 2000-51 |
| Understanding the Results of<br>the Test .....                      | 2000-4  | Troubleshooting .....                | 2000-51 |
| <b>Engine Removal</b> .....   | 2000-5  | <b>Radiator</b> .....                | 2000-53 |
| <b>Torque Converter</b> .....                                       | 2000-22 | Removal .....                        | 2000-53 |
| Removal .....   | 2000-22 | Installation .....                   | 2000-58 |
| Installation .....  | 2000-25 | <b>Turbocharger</b> .....            | 2000-63 |
| <b>Engine Installation</b> .....                                    | 2000-27 | Priming the Turbocharger .....       | 2000-63 |
| <b>Air Cleaner</b> .....  | 2000-43 | Stopping the Engine .....            | 2000-64 |
| Service Interval .....  | 2000-47 | Causes of Turbocharger Failure ..... | 2000-64 |
| Dust Cup .....  | 2000-47 | Removal .....                        | 2000-64 |
|   |         | Installation .....                   | 2000-64 |

## ENGINE REMOVAL

Because the only support for the torque converter is the engine, the torque converter must be removed with the engine.

1. If the machine is a loader, raise the loader frame and lower the strut onto the lift cylinder.

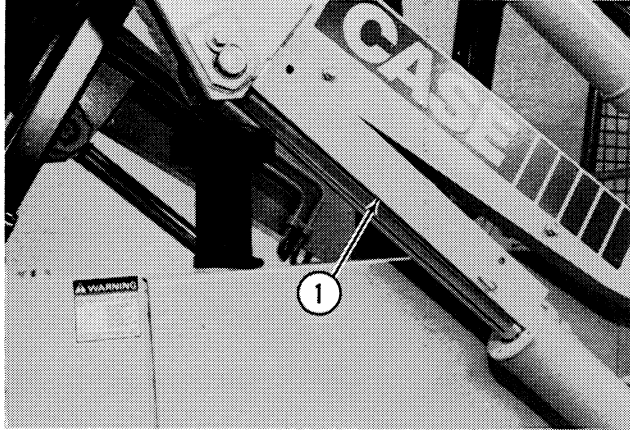

1. Strut

334934

2. If the machine is a dozer, lower the blade to the floor.

3. Loosen and remove the cap screws that hold the side panels in place.

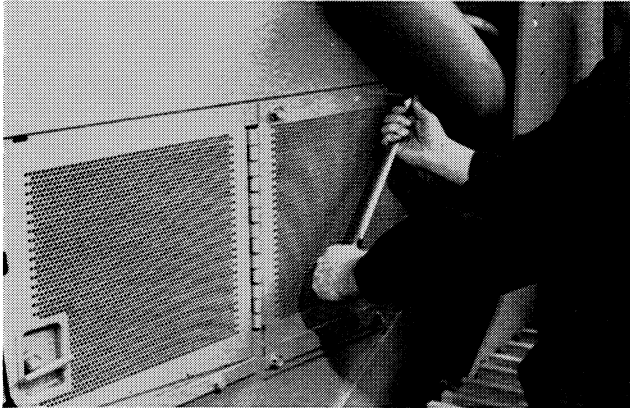

335201

4. Remove both side panels.

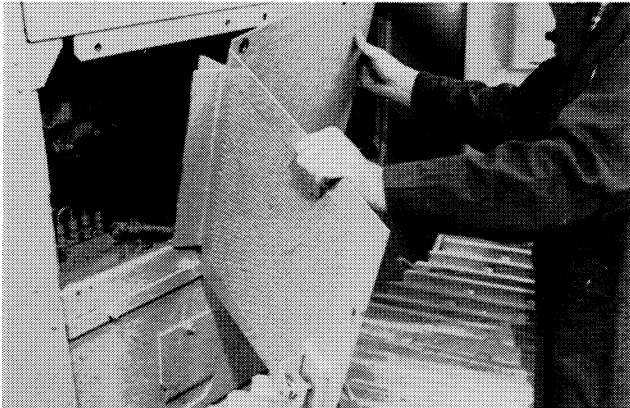

335204

5. Loosen and remove the cap screws, bolts, lock washers, flat washers, and nuts that hold the bottom panels in place.

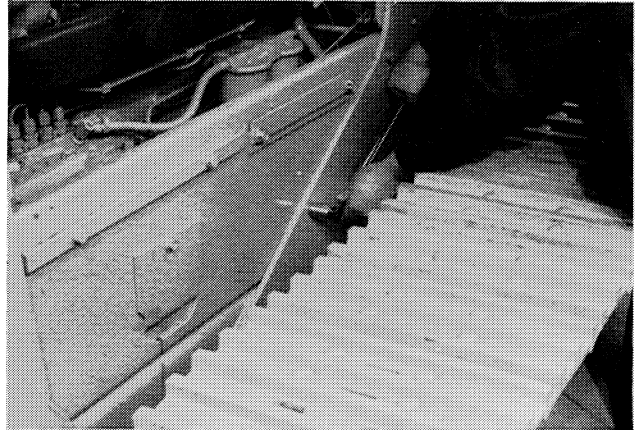

335206

6. Remove both bottom panels.

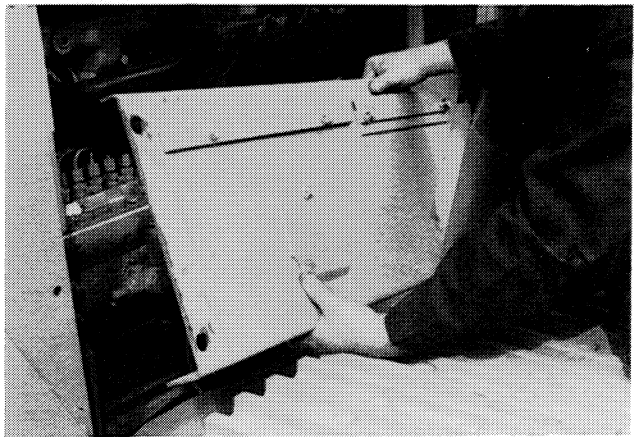

335209

7. Loosen the self-locking nuts on the front hood bolts.

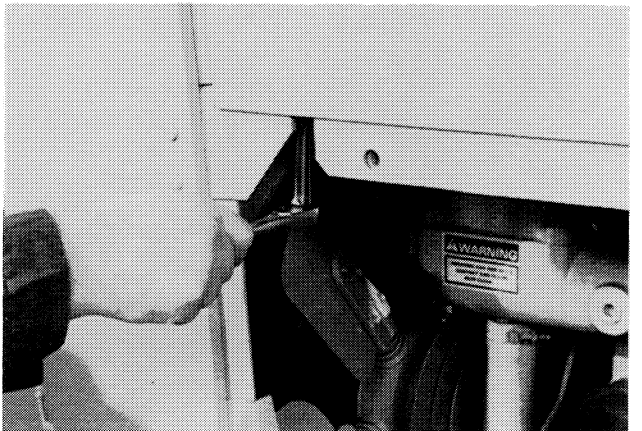

335211

8. Loosen the self-locking nuts on the rear hood bolts.

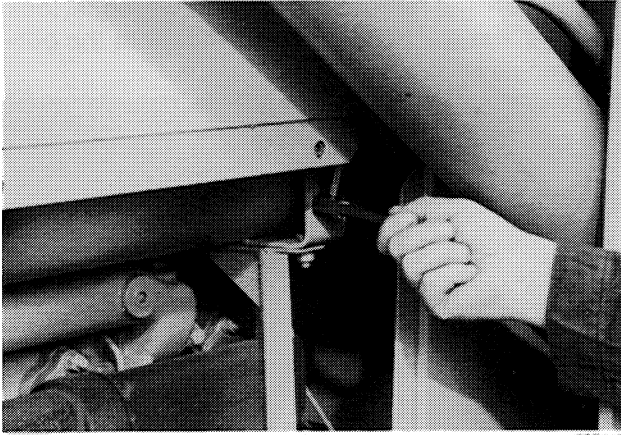

335118

11. Loosen and remove the cap screws that hold the plate at the top of the radiator shroud.



335233

9. Loosen and remove the cap screws that hold the top half of the grille and screen. Do not let the grille and screen fall.



335143

12. Remove the plate.



335319

10. Remove the grille and screen.



335101

13. Loosen and remove the cap screws that hold the plate that supports the bottom half of the grille and screen.

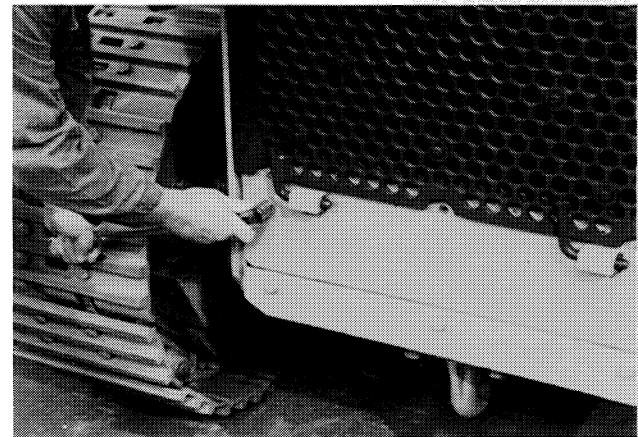

334942

14. Loosen and remove the cap screws that hold the plate that supports the bottom half of the grille and screen.

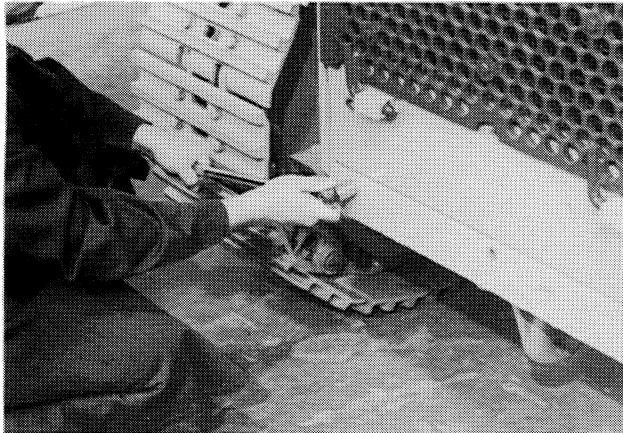

334906

15. Loosen and remove the cap screws that hold the bottom half of the grille and screen. Do not let the grille and screen fall.

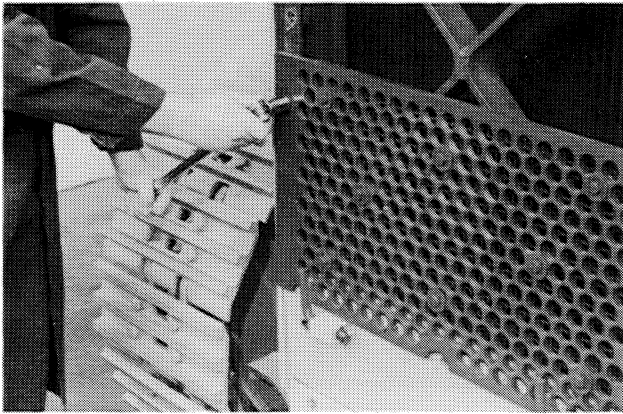

334909

16. Remove the grille, screen, and plate.



334910

17. Remove the front guard (photo, top right). Use an acceptable jack to hold the front guard in place. Loosen and remove the cap screws and flat washers that hold the front guard to the machine.

18. Lower the front guard to the floor and remove the front guard from under the machine.

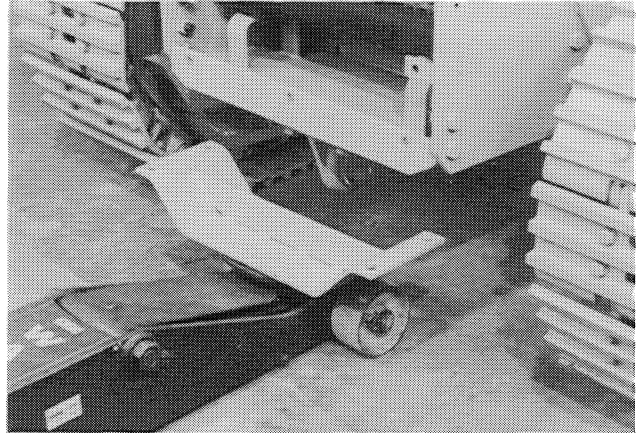

335031

19. Use the same procedure to remove the center guard and both rear guards.

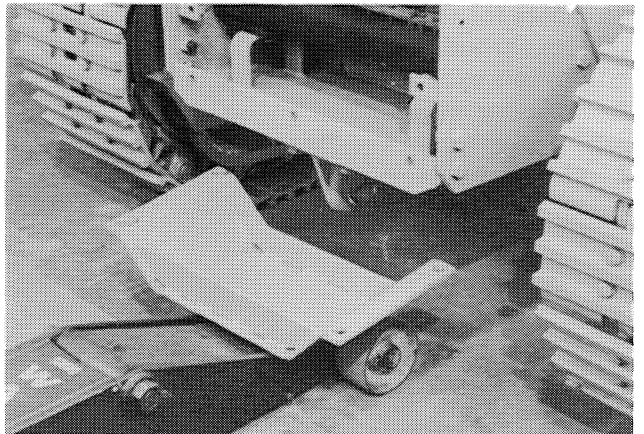

335032

20. Start the engine. Raise the loader frame, and move the strut rearward and install the two cap screws that hold the strut in place.

21. Lower the loader frame to the floor.

22. Stop the engine.

23. Attach acceptable lifting equipment to the brush guard.

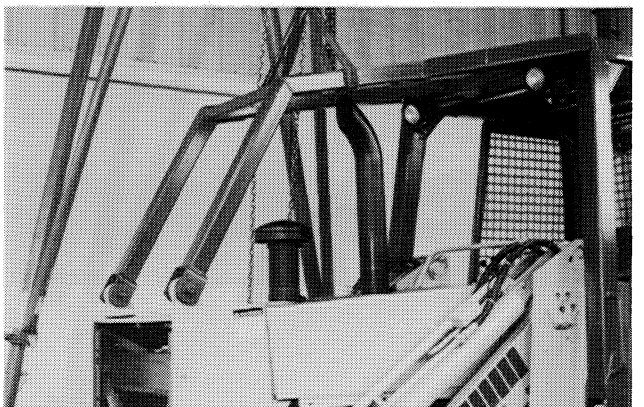

335330

24. Loosen and remove the self-locking nuts and bolts that fasten the rear of the brush guard to the ROPS canopy.

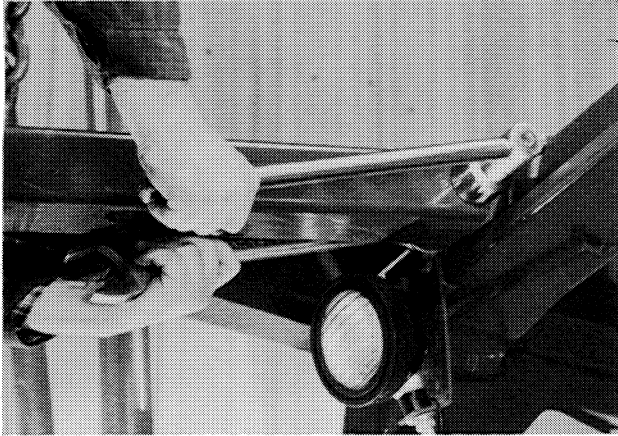

335134

27. Remove the nuts that fasten the horns to the radiator shroud and remove the horns, bolts, and flat washers.

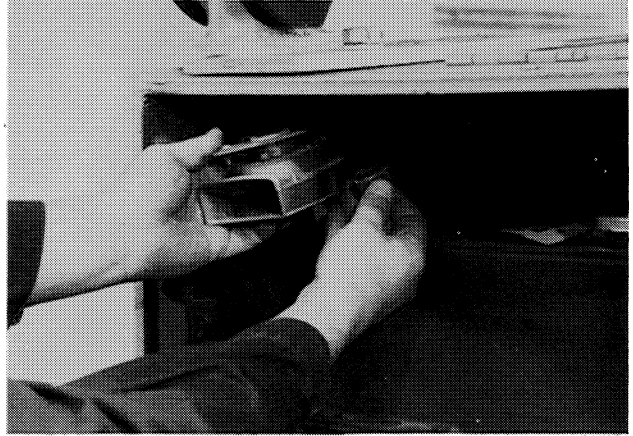

335326

25. Loosen the nuts and bolts that hold the mounting plates for the front of the brush guard to the radiator shroud. Remove all of the nuts, bolts, and flat washers except the two that fasten the horns to the radiator shroud.



335323

28. Carefully remove the brush guard.

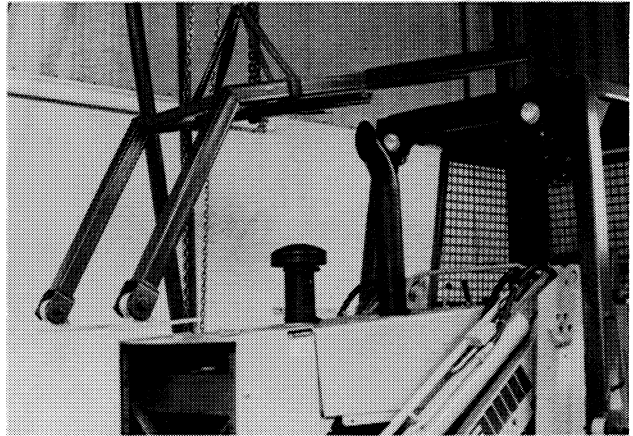

335332

26. Disconnect the harness wires from both horns.



335325

29. If the machine has a turbocharger:

- a. Loosen the muffler clamp at the engine and remove the muffler.
- b. Loosen and remove the cap screw at the rear of the hood.
- c. Remove the hood.

30. If the machine does not have a turbocharger:

- a. Loosen and remove the cap screw at the rear of the hood.

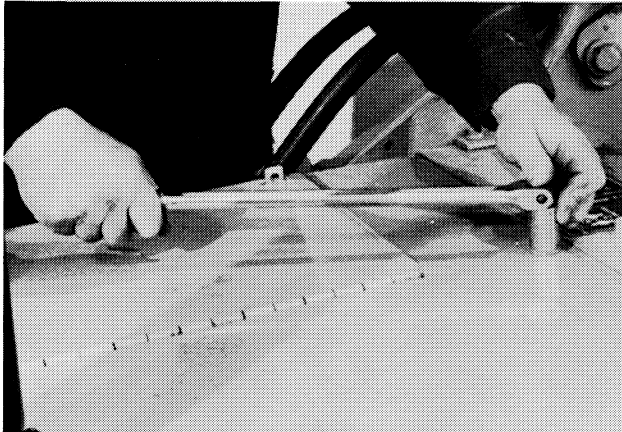

335335

- b. Remove the hood.



335338

31. Start the engine. Raise the loader frame all the way and stop the engine. Remove the cap screws that hold the strut in place and move the strut forward onto the cylinder rod.

32. Lower the loader frame onto the strut.



335341

33. Loosen and remove the radiator cap.

34. Open the drain valve and drain the coolant from the radiator. The cooling system contains 13 U.S. gallons (49 litres) of coolant.

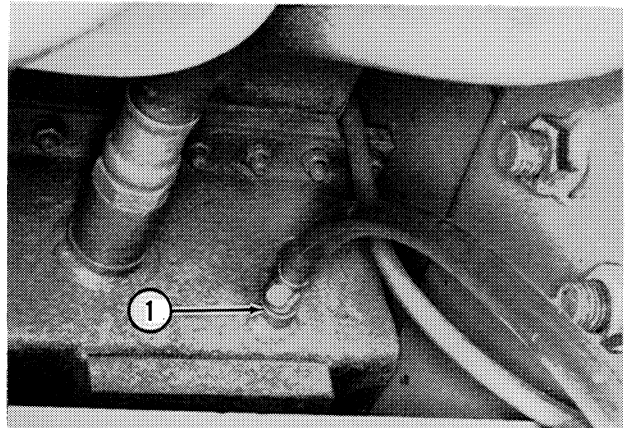

1. Drain Valve

335503

35. If the machine has a radiator with the transmission oil cooler on the side:

- a. Disconnect the top hose on the transmission oil cooler from the tube. Install a plug in the tube and a cap on the hose.
- b. Disconnect the bottom hose on the transmission oil cooler from the tube. Install a plug in the tube and a cap on the hose.

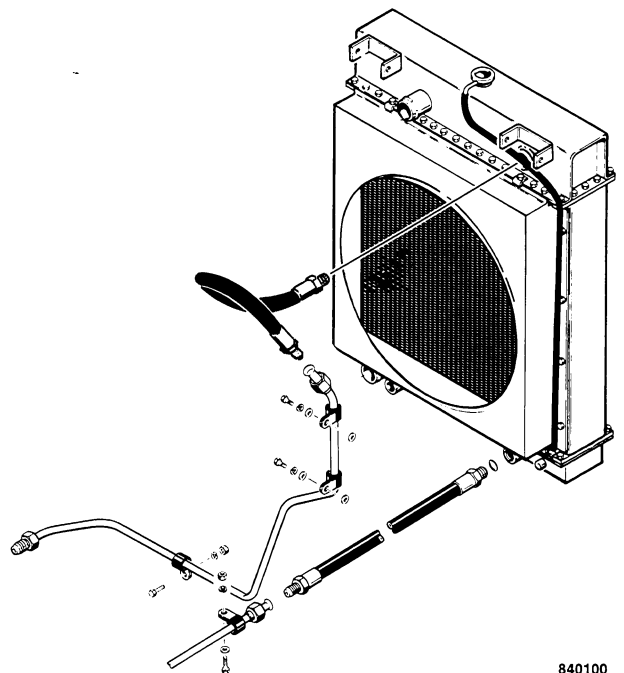

840100

36. If the machine has a radiator with the transmission oil cooler on the bottom:

- a. Disconnect the hose for the right side of the transmission oil cooler.

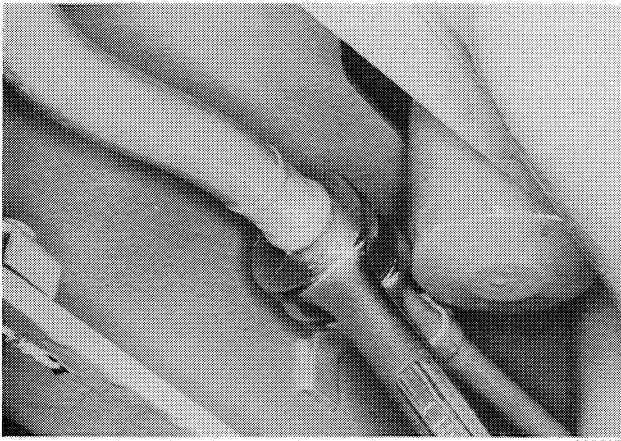

- b. Install a plug in the tube and a cap on the hose.

- c. Disconnect the hose for the left side of the transmission oil cooler.

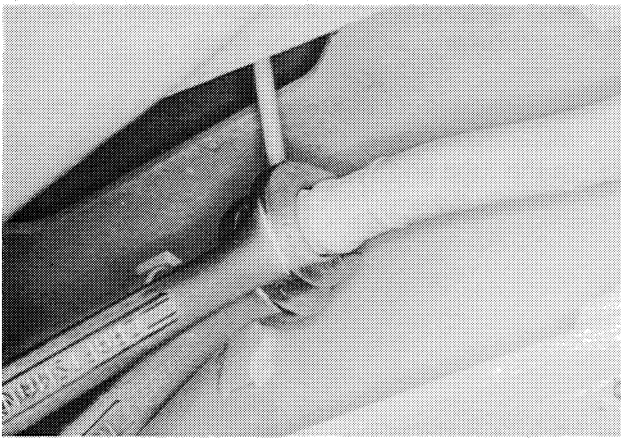

- d. Install a plug in the tube and a cap on the hose.

37. If the machine is a dozer:

- a. Remove the snap rings from the pivot pins that fasten the rod end of the lift cylinders in place.

- b. Remove the pivot pins and spacers.

- c. Disconnect the tubes for the lift cylinders from the tubes at the rear of the engine. Install plugs in the tubes and caps on the fittings.

- d. Disconnect the tubes for the lift cylinders from the tee fittings at the radiator shroud. Install plugs in the tubes and caps on the fittings.

- e. Loosen the cap screws for the clamps that fasten the tubes to the bracket at the rear of the engine.

- f. Remove the tubes for the lift cylinders.

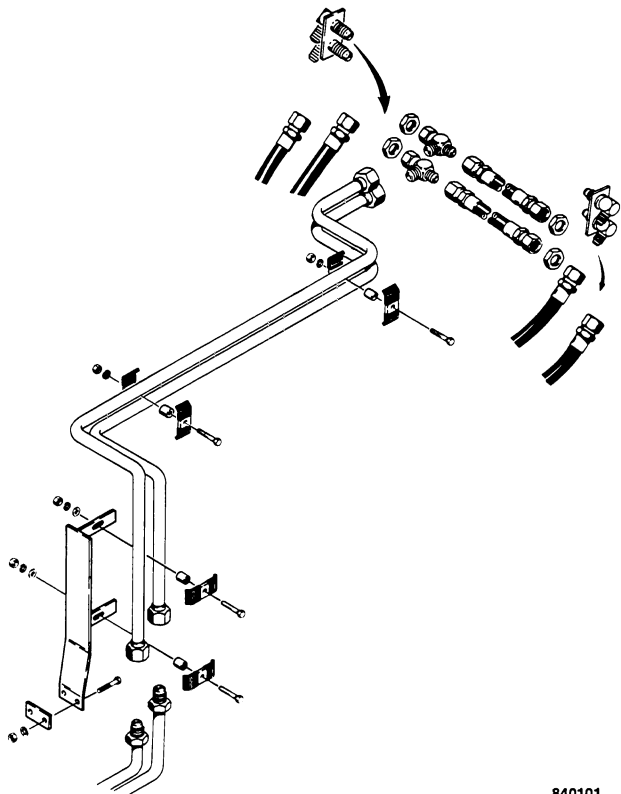

38. Loosen and remove the cap screws, lock washers, and flat washers that hold the radiator to the radiator mounts.

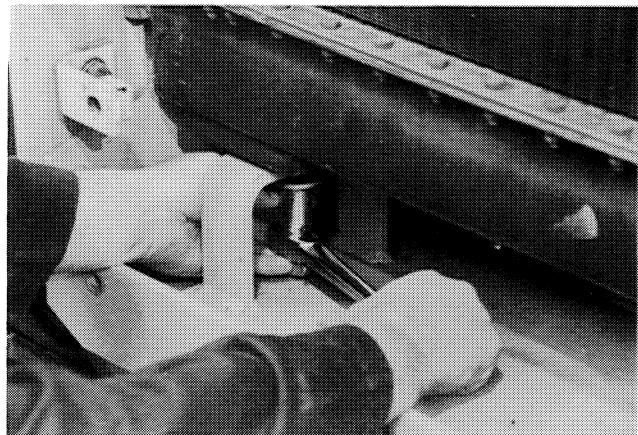

39. Loosen the clamp that holds the bottom radiator hose to the water pump.

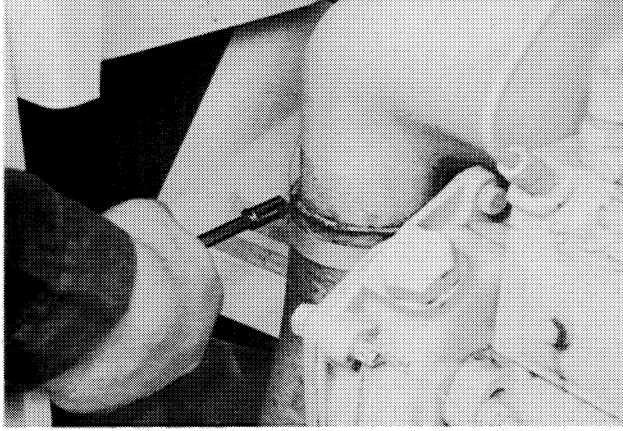

335421

40. Remove the hose.

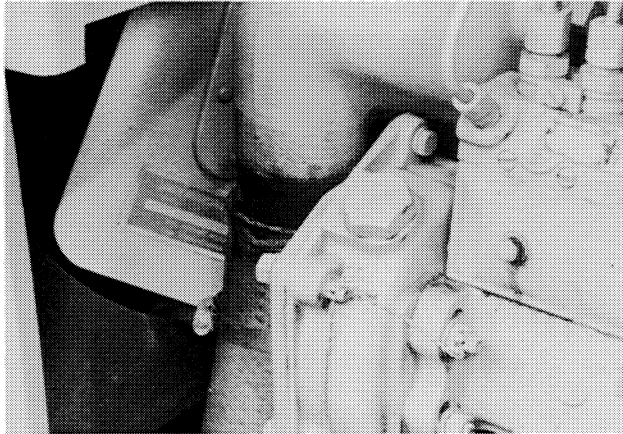

335423

41. Loosen the clamp that holds the top radiator hose to the radiator.

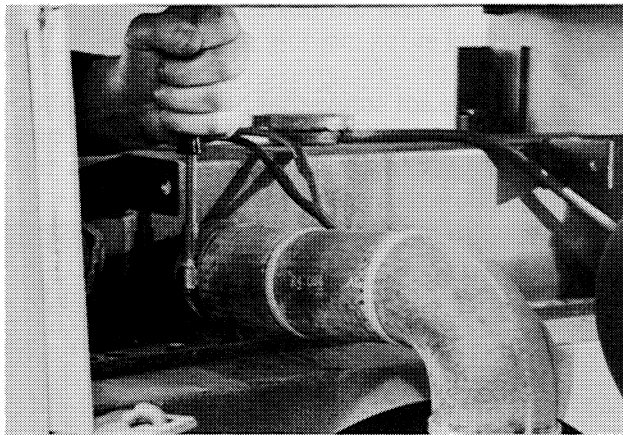

335424

42. Remove the hose.

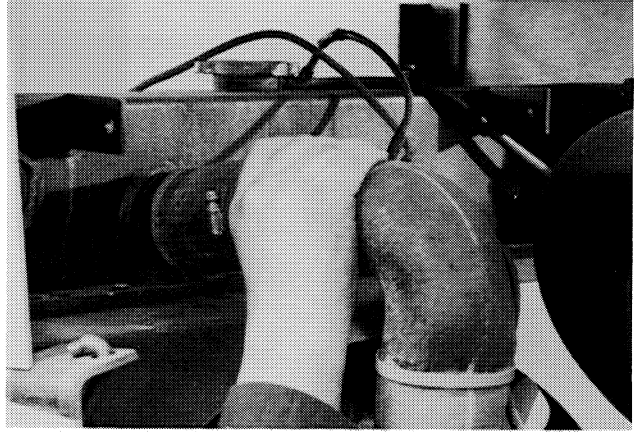

335426

43. Attach acceptable lifting equipment to the radiator shroud and around the inlet tube at the top rear of the radiator.

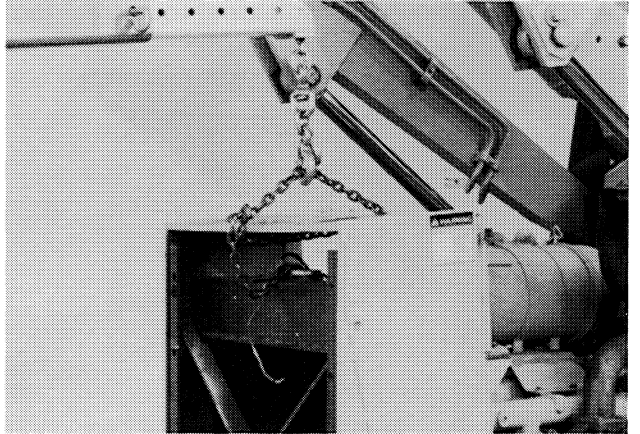

335429

44. Loosen and remove the eight cap screws that hold the radiator shroud to the frame.

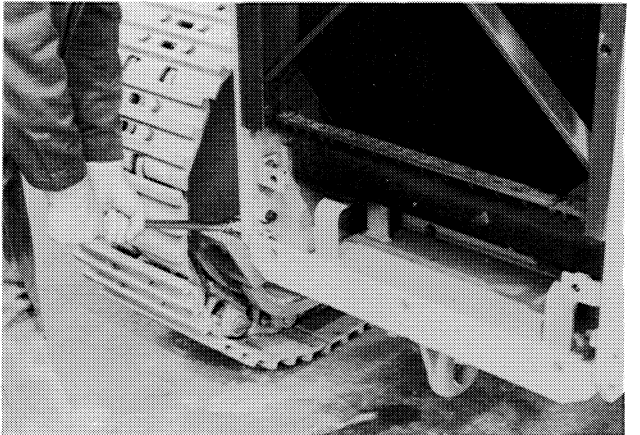

335418

45. Carefully lift the radiator shroud and the radiator.

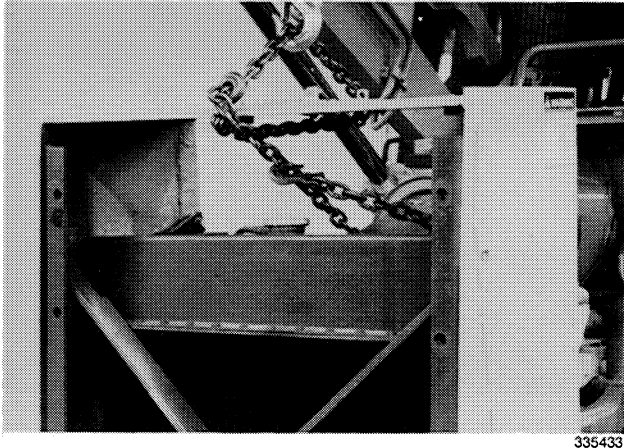

46. Move the radiator shroud forward until the radiator is free of the fan blades. Lift the radiator shroud and remove the radiator shroud from the machine.

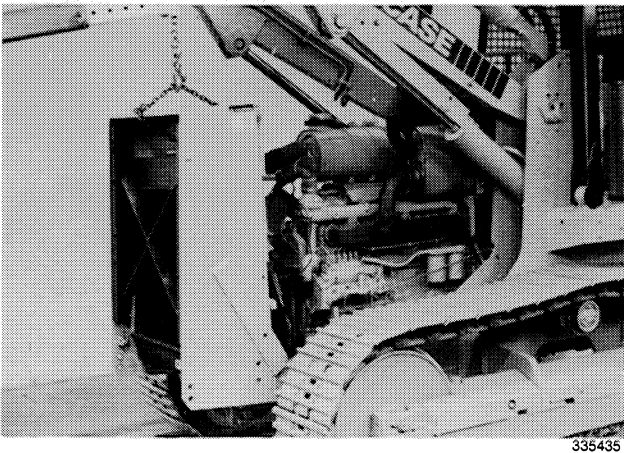

47. Close the shutoff valve in the fuel return line and the fuel supply line.

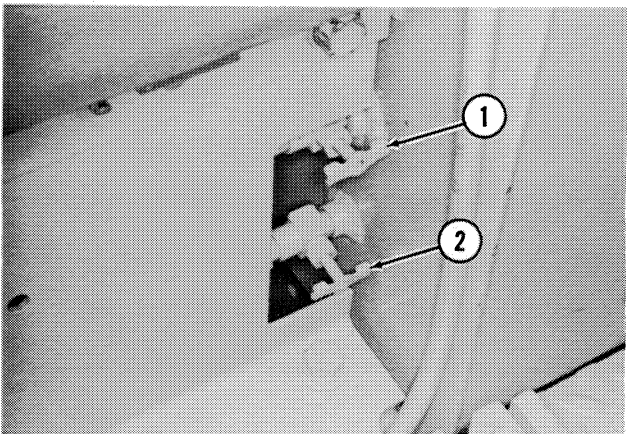

1. Shutoff Valve (Fuel Return Line)
2. Shutoff Valve (Fuel Supply Line)

48. Disconnect the fuel line from the transfer pump.

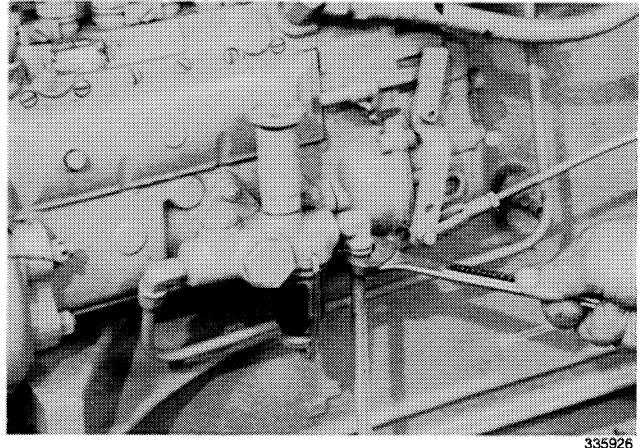

49. Remove the retaining clip for the clevis pin that connects the accelerator rod to the fuel injection pump, and remove the clevis pin.

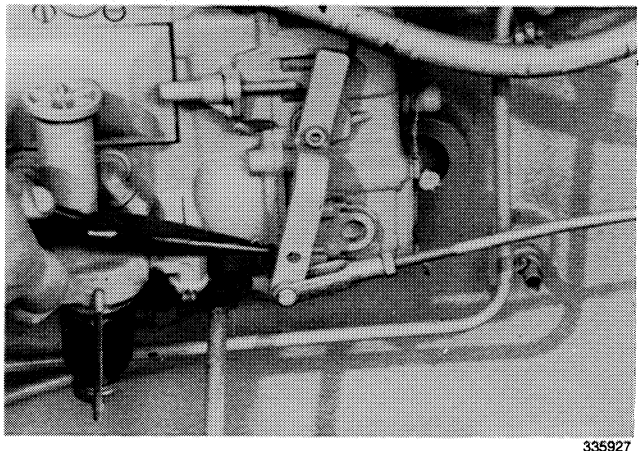

50. Pull out the fuel shutoff control until the fuel shutoff control stops moving.

51. Loosen the set screw that holds the fuel shutoff cable in place at the fuel injection pump. Loosen and remove the cap screws and clamps that fasten the cable to the engine.

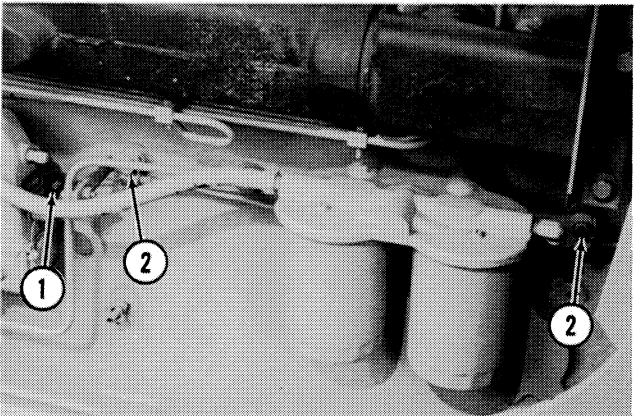

1. Set Screw
2. Cap Screws

52. Disconnect the fuel supply tube. Install a plug in the tube and a cap on the fitting.

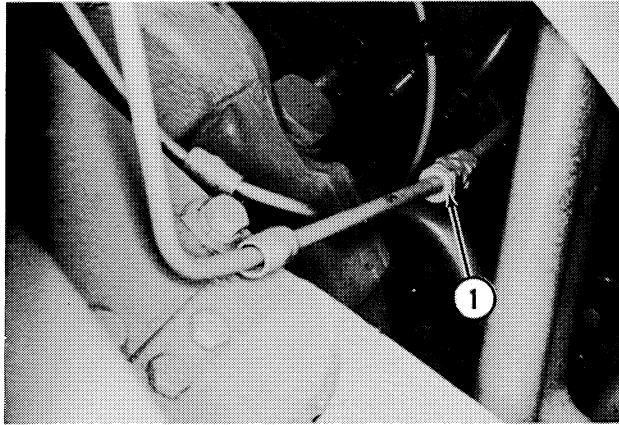

1. Connector

335637

53. If the machine is a dozer and the engine has a turbocharger:

- a. Loosen the clamp that fastens the air cleaner hose to the turbocharger.
- b. Disconnect the line to the restriction indicator at the air cleaner.
- c. Loosen and remove the self-locking nuts, cap screws, lock washers, and flat washers that hold the air cleaner bracket in place.
- d. Remove the air cleaner and air cleaner hose from the engine.
- e. Remove any sealant from the inlet of the turbocharger.
- f. Cover or close the opening at the inlet of the turbocharger.

54. If the machine is a loader and the engine has a turbocharger:

- a. Loosen the clamp that fastens the air cleaner hose to the turbocharger.
- b. Remove the air cleaner hose from the turbocharger.
- c. Disconnect the line to the restriction indicator at the air cleaner.
- d. Loosen and remove the cap screws, lock washers, and flat washers that hold the air cleaner bracket in place.
- e. Remove the air cleaner from the engine.

f. Remove any sealant from the inlet of the turbocharger.

g. Cover or close the opening at the inlet of the turbocharger.

55. If the engine does not have a turbocharger:

a. Loosen the clamp that fastens the air cleaner hose to the intake manifold.

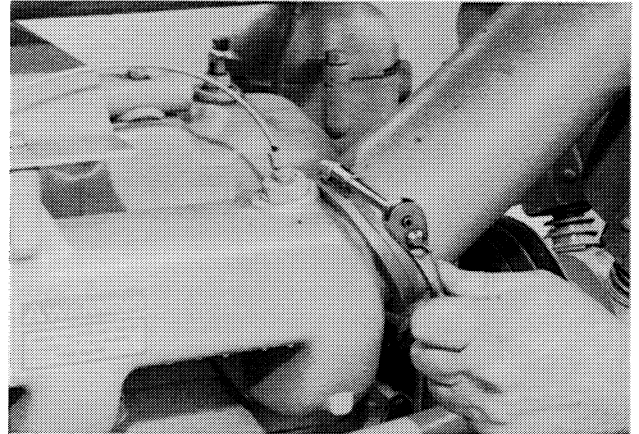

335931

b. Remove the air cleaner hose.

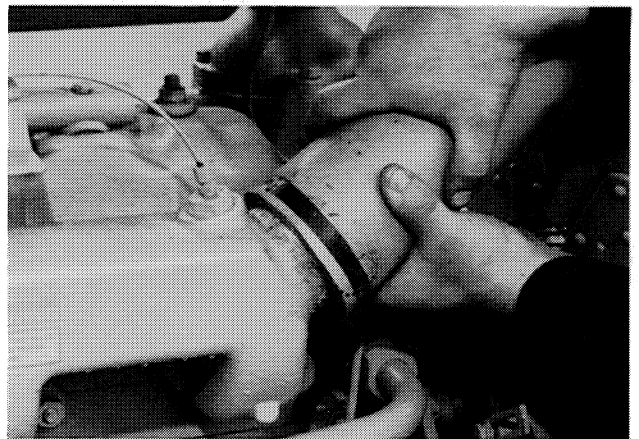

335933

c. Remove any sealant from the intake manifold, and cover or close the opening in the intake manifold.

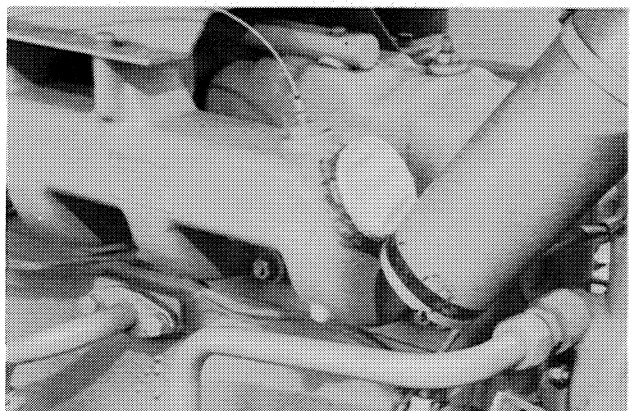

335935

d. If equipped with ether injection, disconnect the line at the front of the intake manifold.

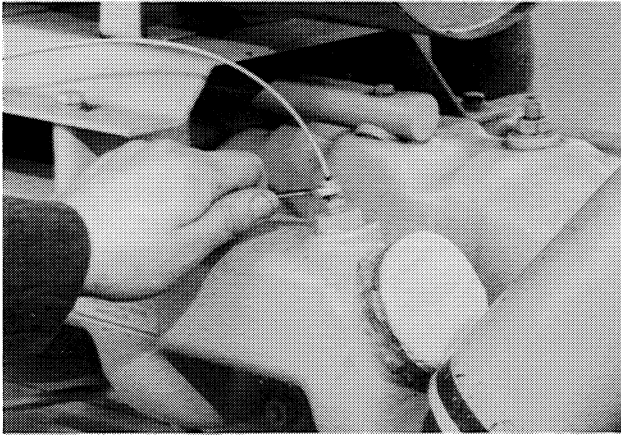

335937

e. Loosen and remove the cap screws, lock washers, flat washers, and clamp that fastens the ether injection line and air cleaner bracket to the engine.

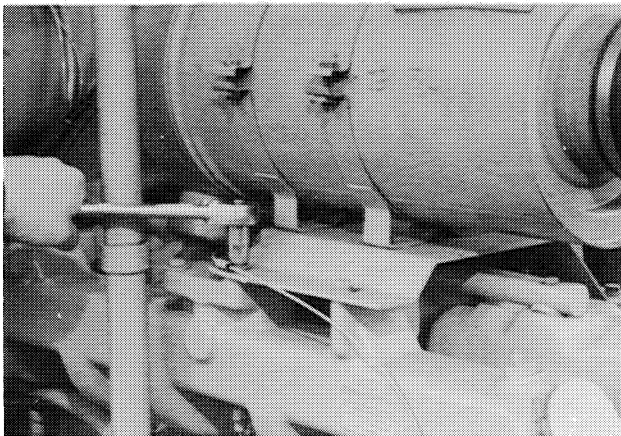

335939

f. Remove the air cleaner.

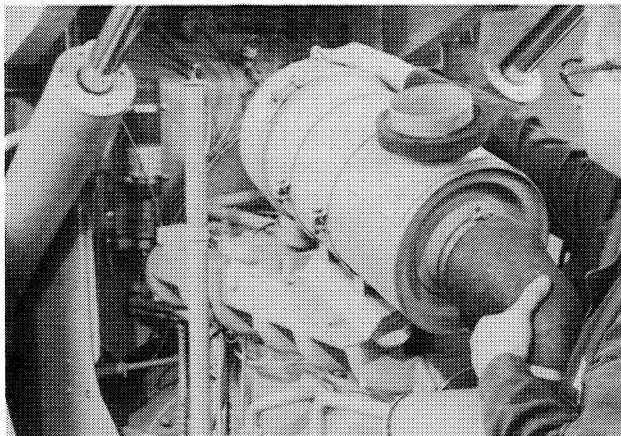

335941

56. Loosen and remove the nut, flat washer, and clamp from the rear valve cover stud. Loosen and remove the sensor for the engine temperature from the water manifold.

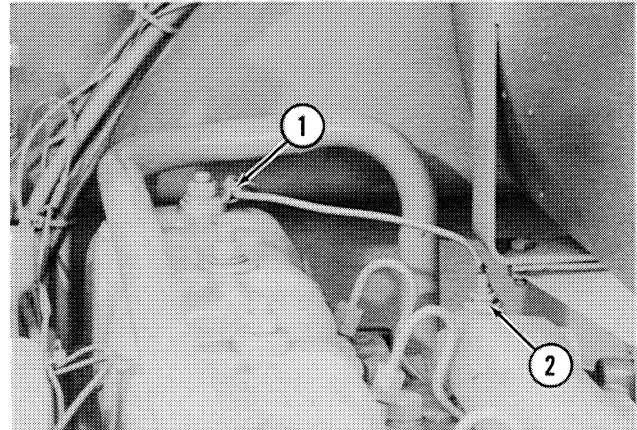

335944

1. *Clamp*
2. *Sensor*

57. Disconnect the ground cable from the battery.

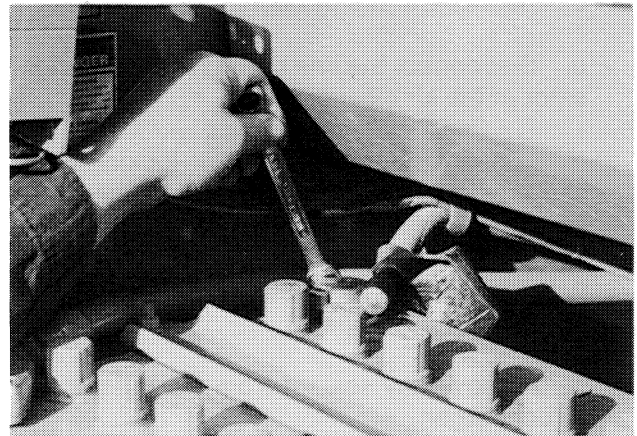

836467

58. Disconnect the wire for the horns.

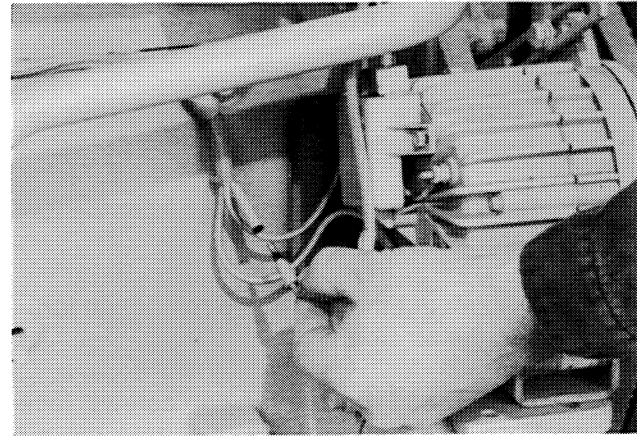

335906

59. Loosen and remove the nut, lock washer, and wire from the BAT terminal of the alternator.

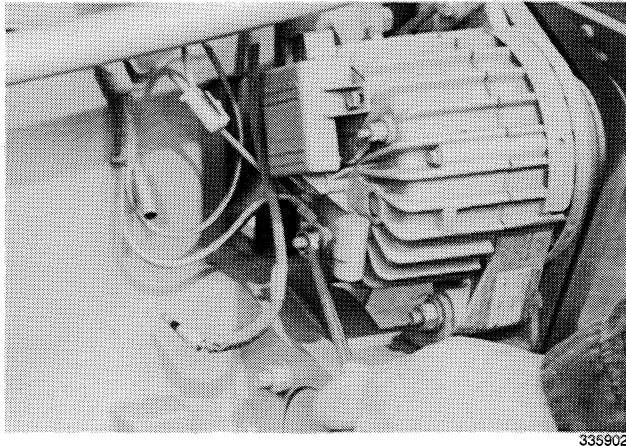

62. Loosen and remove the nut and battery ground cable from the starter.

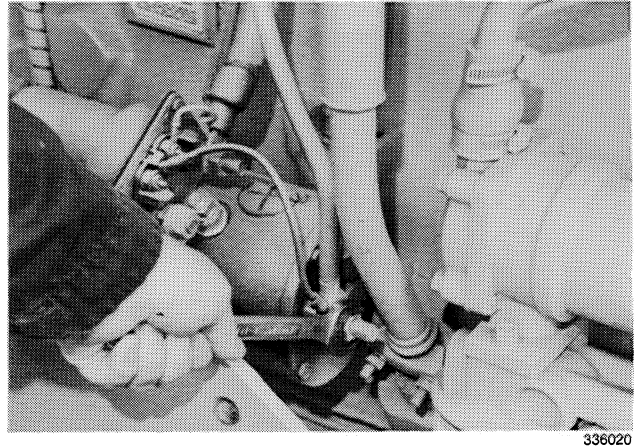

60. Loosen and remove the cap screw, lock washer, and clamp that fastens the front wiring harness to the engine. Loosen and remove the nut, lock washer, flat washer, and clamp that fastens the front wiring harness to the intake manifold.

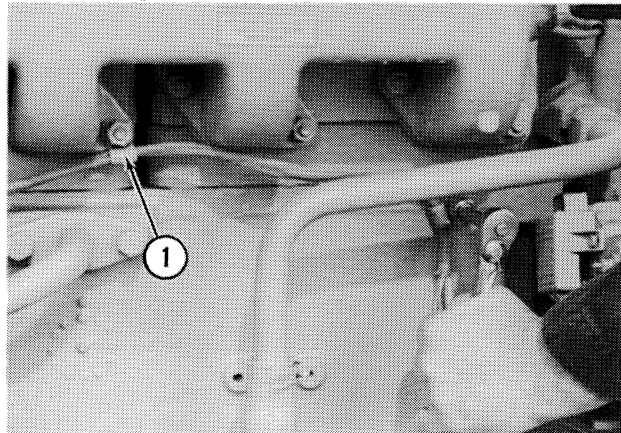

1. Clamp

63. Loosen and remove the nut and positive cable from the starter solenoid. Loosen and remove the nut and wire from the starter solenoid.

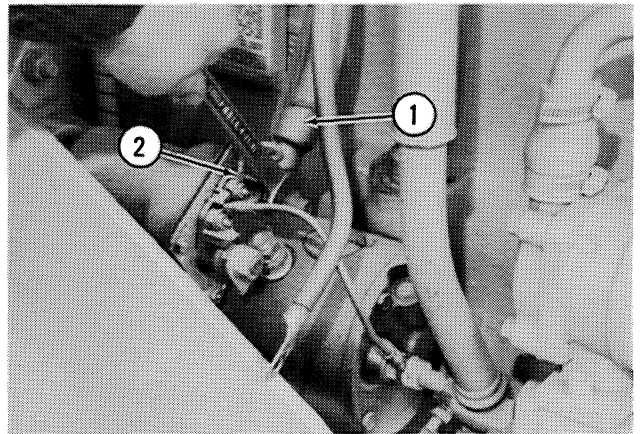

1. Positive Cable  
2. Wire

61. Disconnect the line to the restriction indicator at the intake manifold on engines without a turbo-charger.

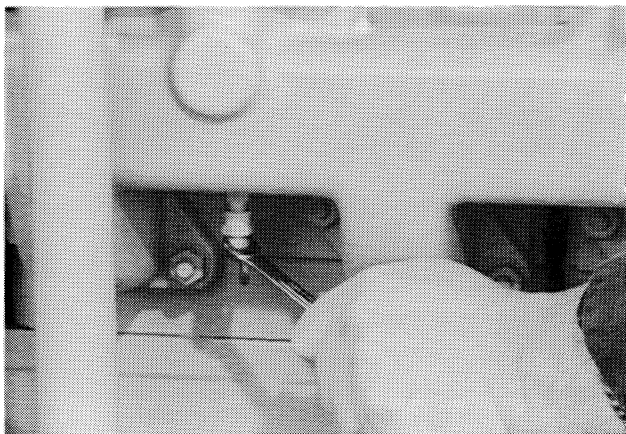

64. Loosen and remove the nuts and the wires to the circuit breakers.

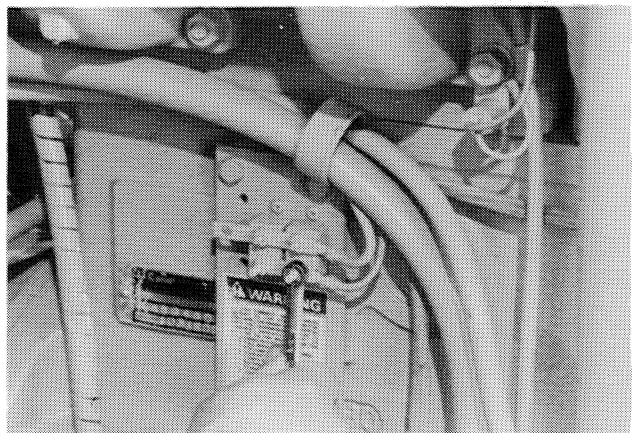

336025

65. Loosen and remove the cap screw, lock washer, and clamp that fastens the cables to the bracket for the circuit breakers.

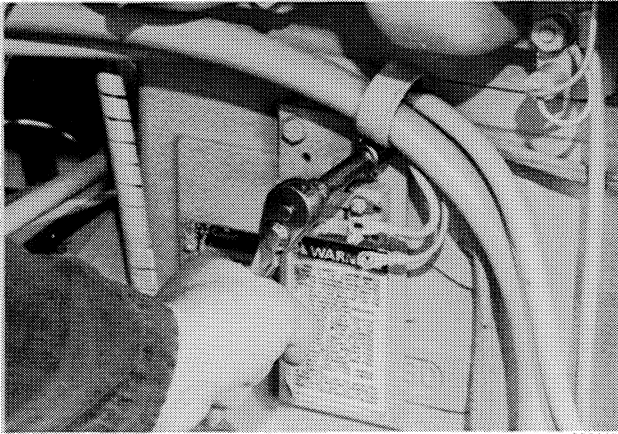

336027

68. Loosen and remove the nut and clamp that fastens the wiring and cables to the rear of the intake manifold.

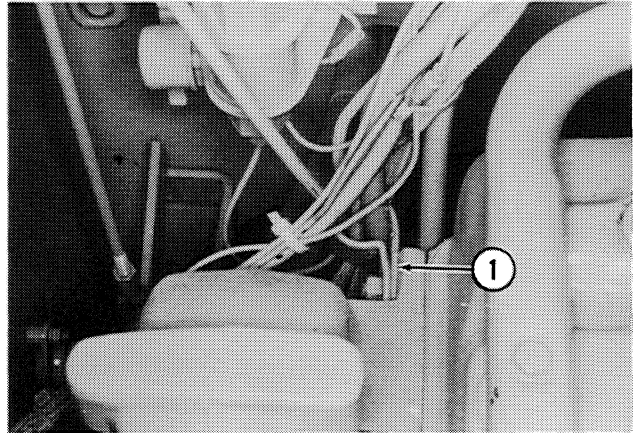

335631

1. Clamp

66. Remove the boot and loosen and remove the tachometer cable from the engine.

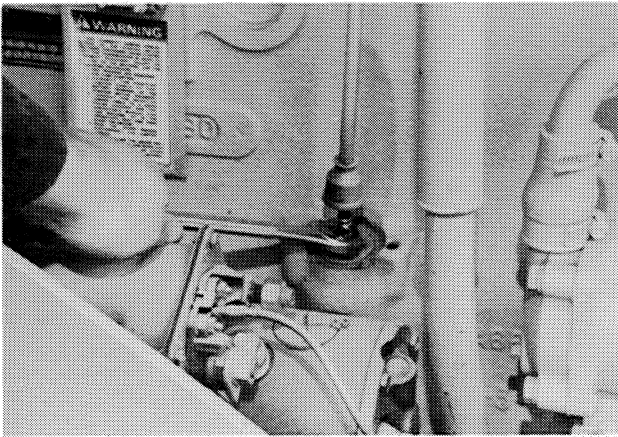

336028

69. Remove the spring for the accelerator pedal.

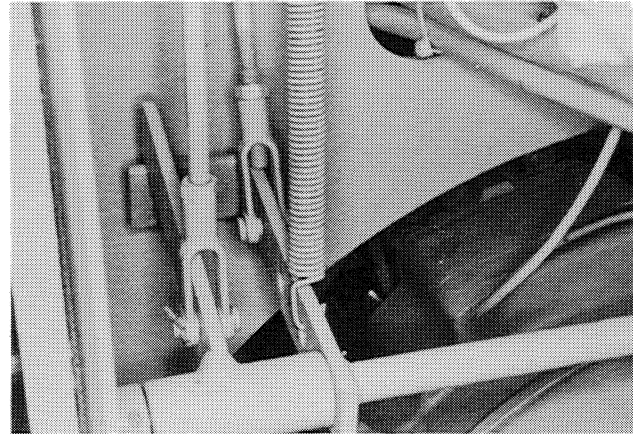

335526

67. Loosen and remove the nut, lock washer, flat washer, and clamp for the tachometer cable. If equipped with ether injection, remove the temperature switch.

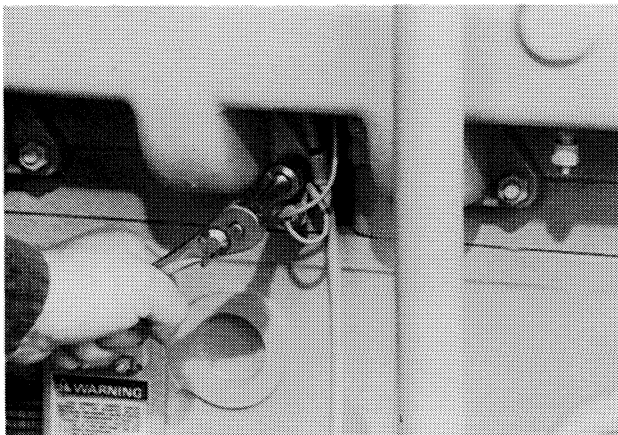

336030

70. Remove the cotter pin and clevis pin that connects the accelerator pedal to the throttle cross shaft. Remove the cotter pin and clevis pin that connects the hand throttle to the throttle cross shaft.

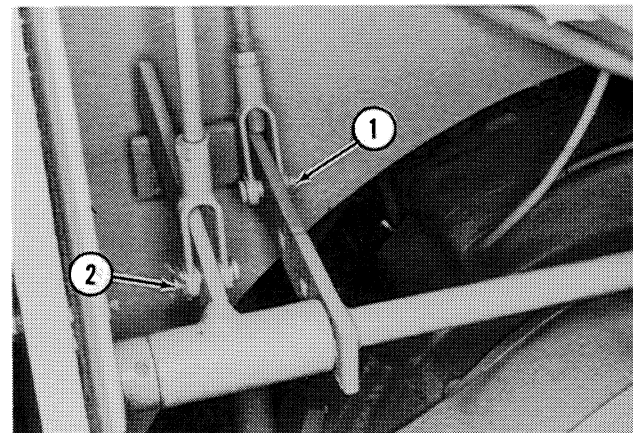

335530

1. Clevis Pin for Accelerator Pedal  
2. Clevis Pin for Hand Throttle

71. Loosen and remove the cap screws that hold the floor plates for the accelerator pedal and the brake pedals. Remove the floor plates.

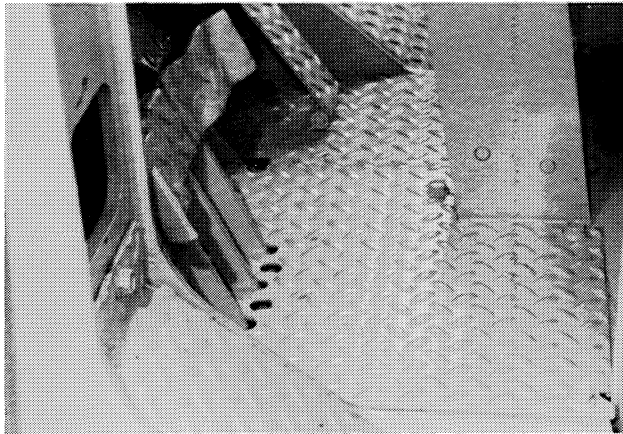

335924

72. Loosen and remove the nuts, lock washers, bolts, spacers, and retainers that hold the throttle cross shaft to the right side of the frame.

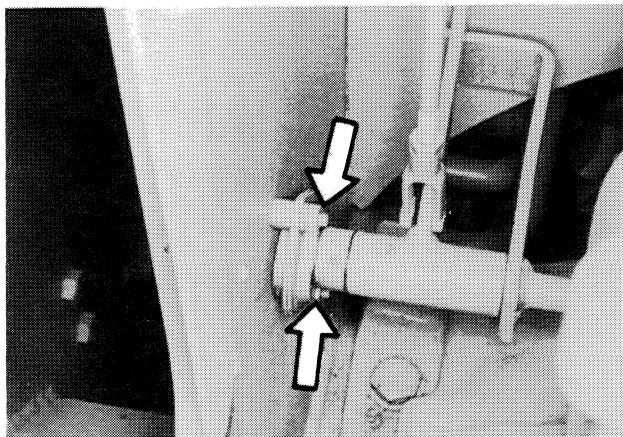

335533

73. Loosen and remove the nuts, lock washers, bolts, spacers, and retainers that hold the throttle cross shaft to the left side of the frame.

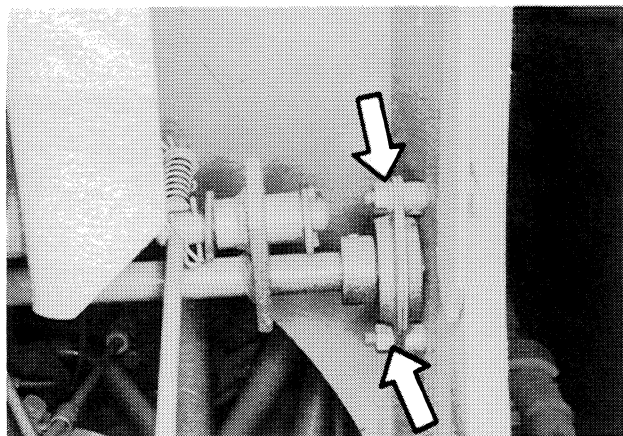

335629

74. Remove the throttle cross shaft.

75. Drain the oil from the transmission.

- a. The transmission holds approximately 14 U.S. gallons (53 litres) of oil.
- b. Put a container under the drain plug.
- c. Remove the drain plug.

76. Disconnect the hose from the top of the torque converter housing. Install a cap on the fitting and a plug in the hose.

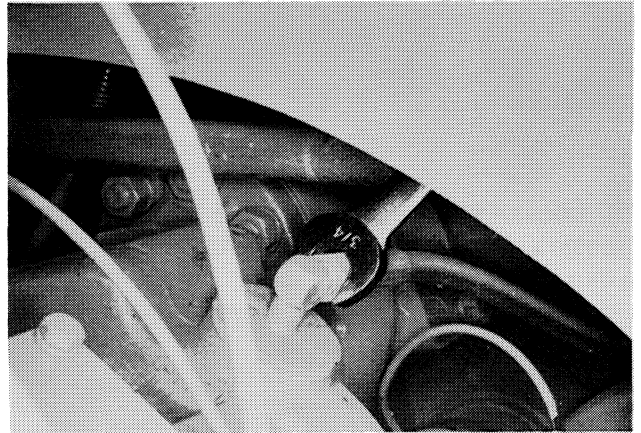

335634

77. Disconnect the hose from the fitting below the starter. Install a cap on the fitting and a plug in the hose.

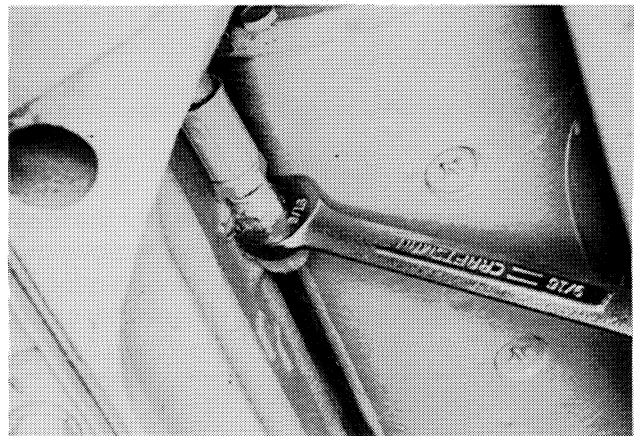

335633

78. Loosen the hose clamp on the hose for the tube to the transmission.

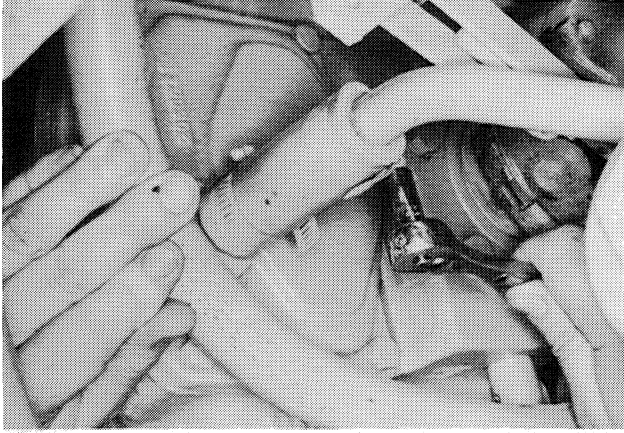

335639

79. Loosen and remove the hose fitting from the transmission. Install a plug in the transmission and a cap on the hose fitting.

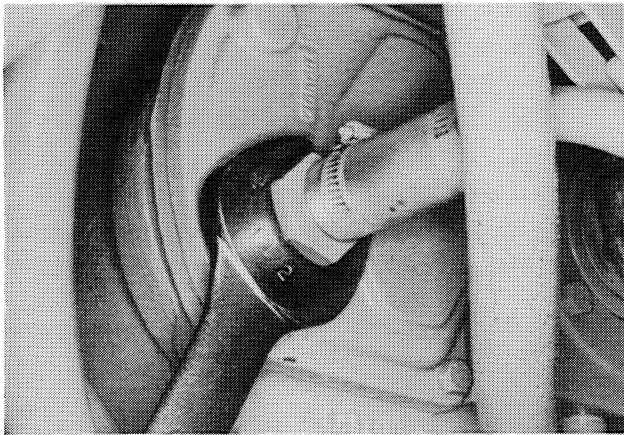

335644

80. Loosen the hose clamp on the hose for the tube to the torque converter. Loosen and remove the hose fitting from the torque converter and remove the tube. Install a plug in the torque converter and a cap on the hose fitting.

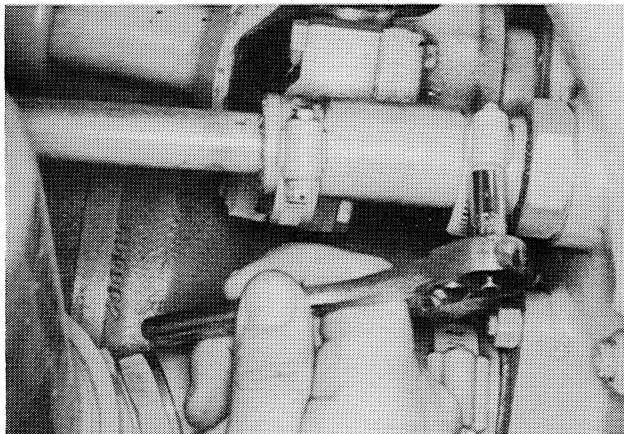

335642

81. If the machine is a dozer:

- a. Loosen and remove the nuts that fasten the drive shaft guards to the transmission.
- b. Remove the drive shaft guards.

82. Loosen and remove the cap screws that hold the drive shaft to the torque converter.

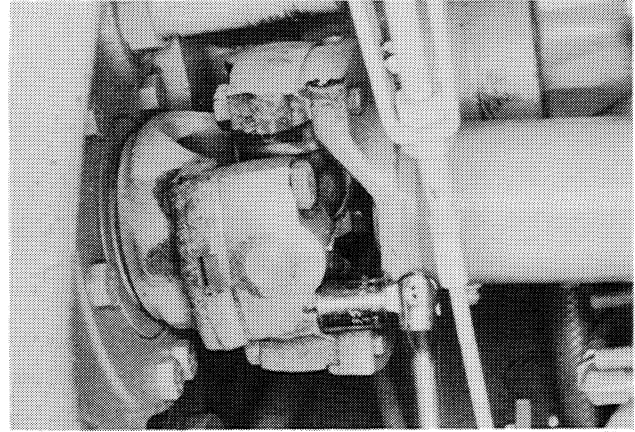

335603

83. Loosen and remove the cap screws that hold the drive shaft to the transmission.

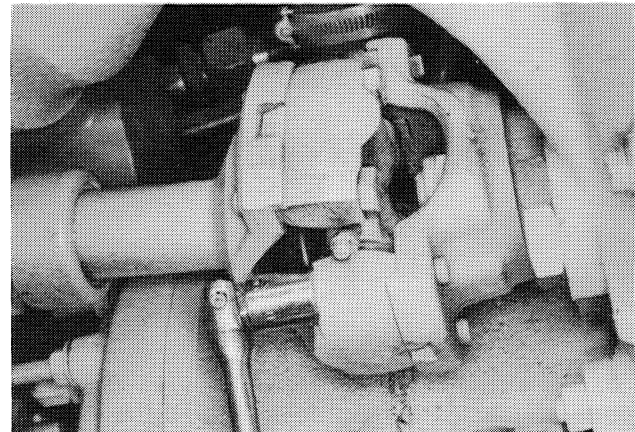

335609

84. Remove the drive shaft.

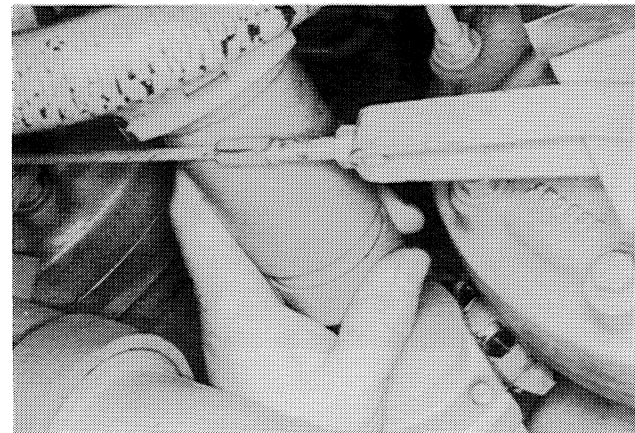

335813

85. Loosen and remove the nut that holds the sensor for the torque converter temperature gauge and remove the sensor.

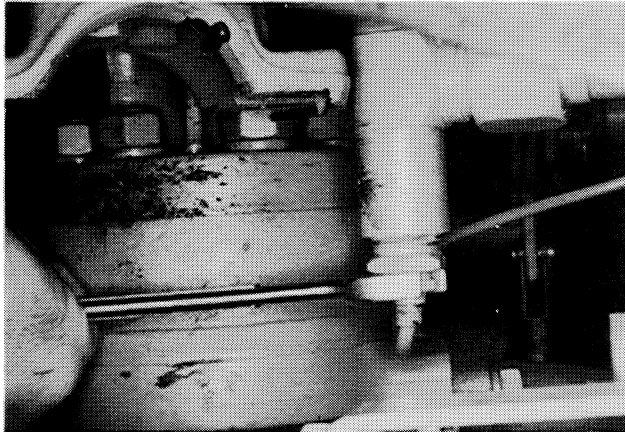

335613

86. Disconnect the tube from the tee fitting in the torque converter. Install a plug in the tube and a cap on the tee fitting.

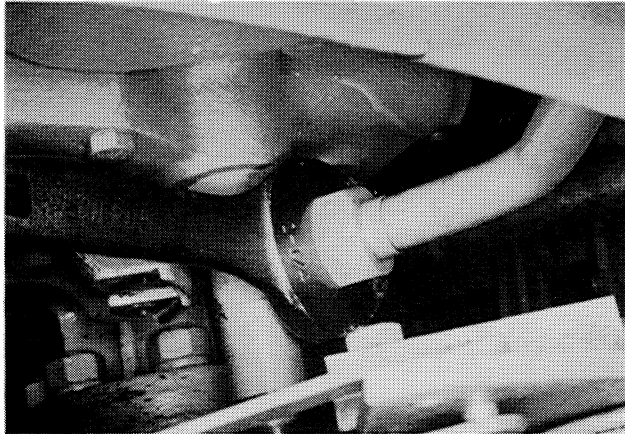

335614

87. Disconnect the hose at the bottom of the torque converter housing.

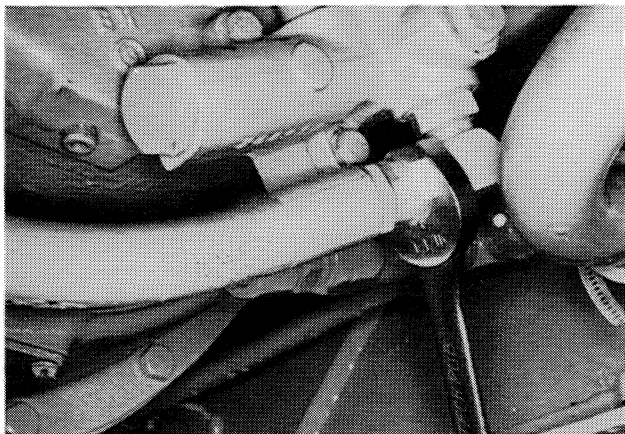

335734

88. Loosen and remove the self-locking nuts and flat washers at the bottom of the equipment pump. Loosen the self-locking nuts at the top of the equipment pump. Use a prybar to pull the equipment pump away from the torque converter and remove the self-locking nuts and flat washers.

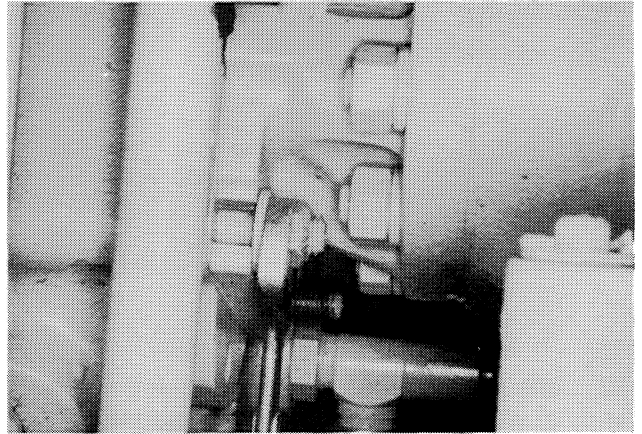

335737

89. Loosen and remove the cap screws and lock washers that hold the charging pump. Pull the charging pump away from the torque converter.

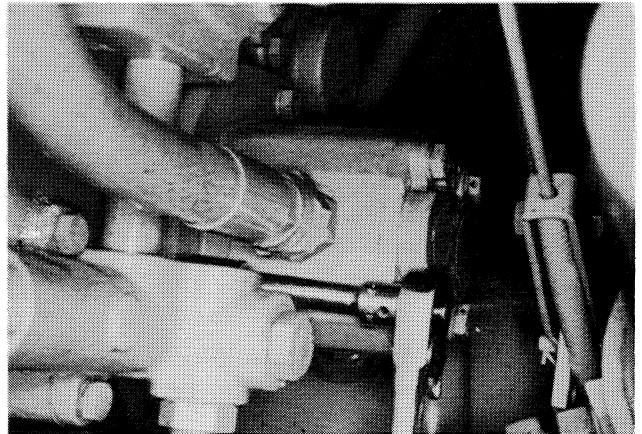

335730

90. If the machine has air conditioning:

- a. Loosen and remove the self-locking nut, bolt, and flat washer that hold the air conditioning compressor to the adjusting bracket.
- b. Loosen and remove the self-locking nut and bolt that hold the air conditioning compressor to the mounting bracket.
- c. Remove the belt from the clutch of the air conditioning compressor.
- d. Disconnect the wire for the clutch from the wiring harness.
- e. Put the air conditioning compressor out of the way.

91. Install the lifting fixture on the engine.

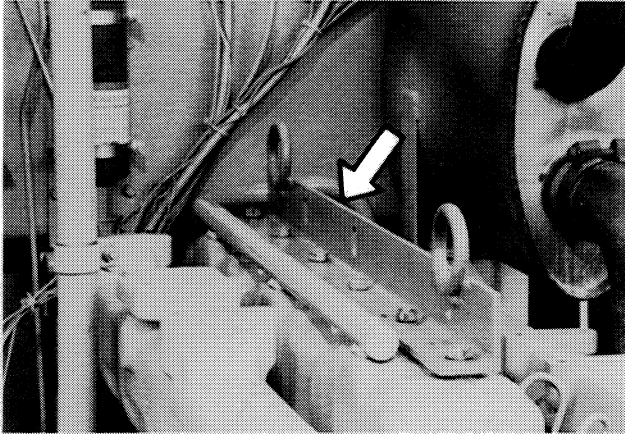

336033

92. Loosen and remove the self-locking nut, bolt, and flat washer for the front motor mount.

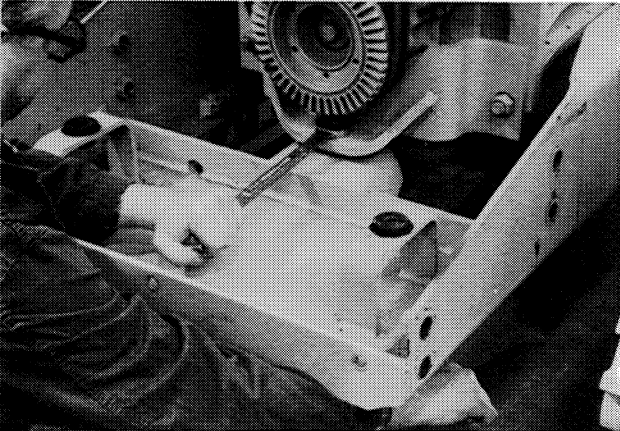

336035

93. Loosen and remove the self-locking nut, flat washers, bolt, and insulator for the right motor mount.

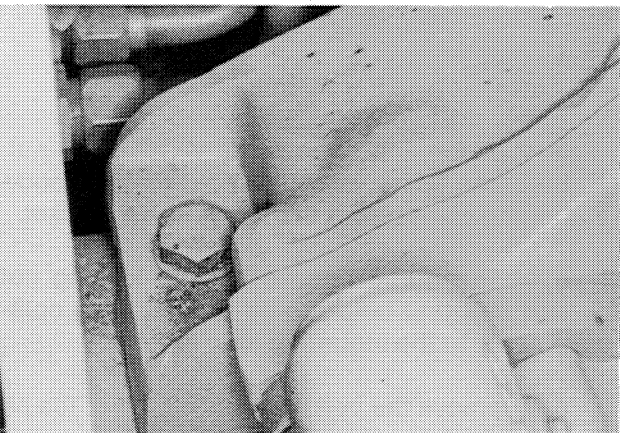

335740

94. Loosen and remove the self-locking nut, flat washers, bolt, and insulator for the left motor mount.

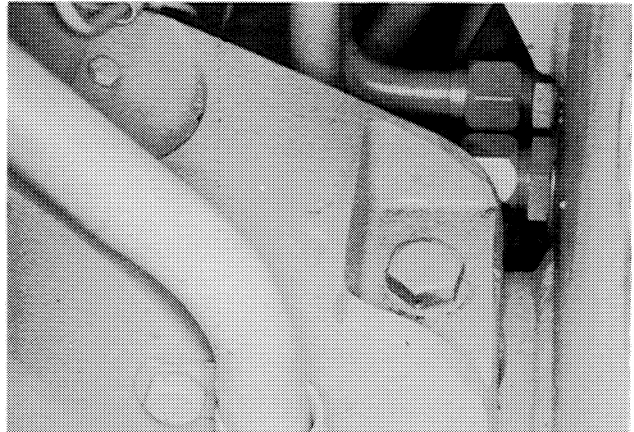

335739

95. Connect acceptable lifting equipment to the lifting fixture.

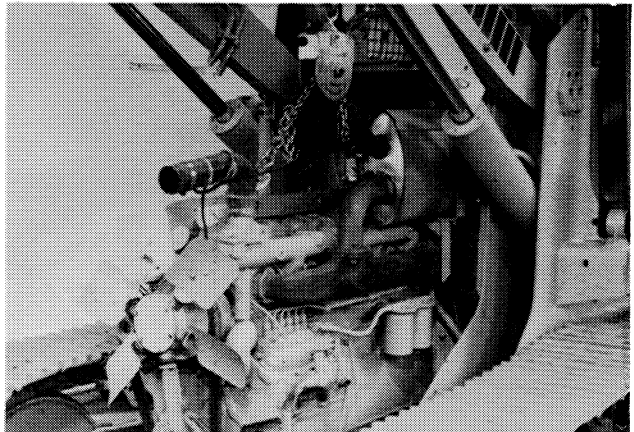

336228

96. Carefully lift the engine and pull the engine forward. Make sure that the equipment pump and the charging pump are free of the torque converter.

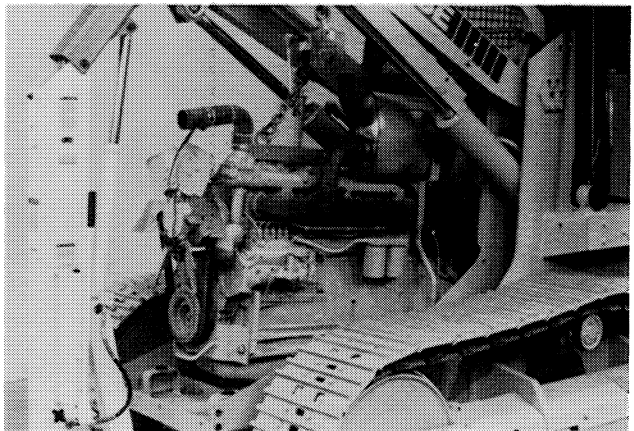

336039

97. Lift the engine above the frame and carefully remove the engine.

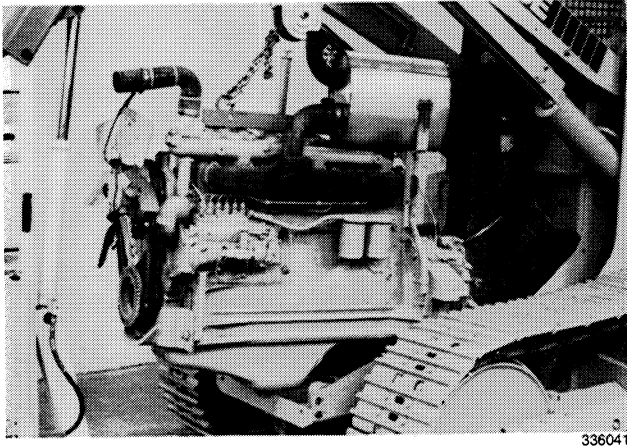

336041

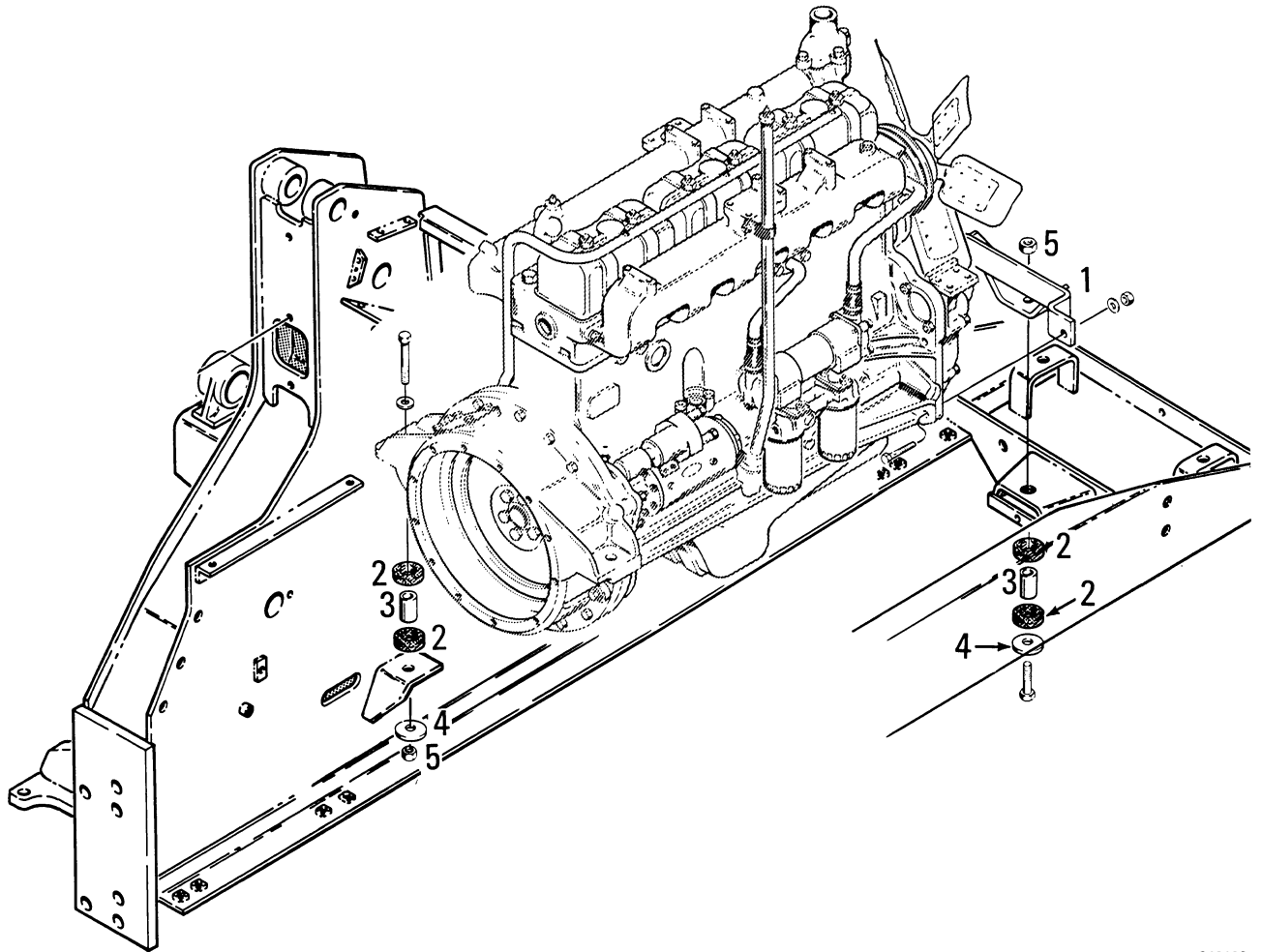

- 1. Front Engine Mount
- 2. Insulator

- 3. Spacer
- 4. Flat Washer

- 5. Self-Locking Nut

## TORQUE CONVERTER

### Removal

1. Remove the old gaskets for the equipment pump and the charging pump from the torque converter. If necessary, remove the old gaskets from the equipment pump and the charging pump.

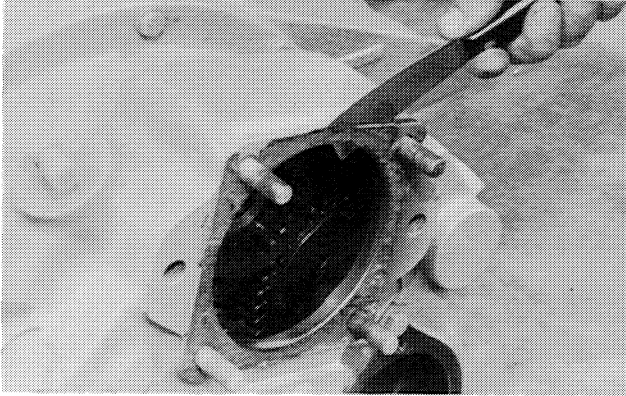

336042

2. Loosen and remove the cap screws and lock washers that hold the clamp for the fuel line and the cover to the top of the flywheel housing.

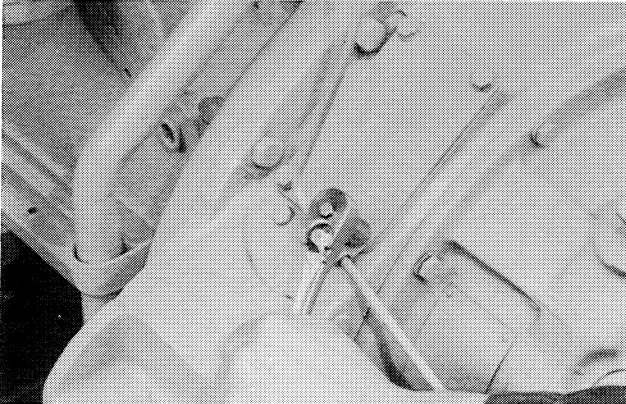

336136

3. Move the fuel line out of the way, and remove the cover.

4. Loosen and remove the two cap screws and special washers at the top of the opening.

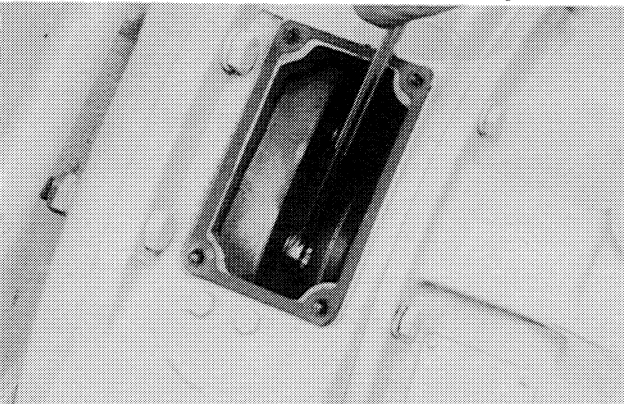

336137

5. Turn the crankshaft to move two more cap screws to the top of the opening.

6. Repeat steps 4 and 5 until all of the cap screws have been removed.

7. Loosen and remove all but the top two cap screws and lock washers that hold the torque converter in place.

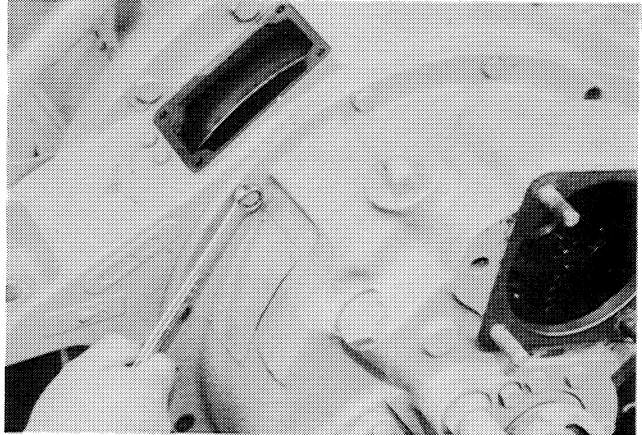

336140

8. Attach acceptable lifting equipment to the torque converter. Loosen and remove the two top cap screws and lock washers. Install cap screws in the threaded holes in both sides of the torque converter. Turn the cap screws into the threaded holes to pull the torque converter away from the flywheel housing. Carefully remove the torque converter.

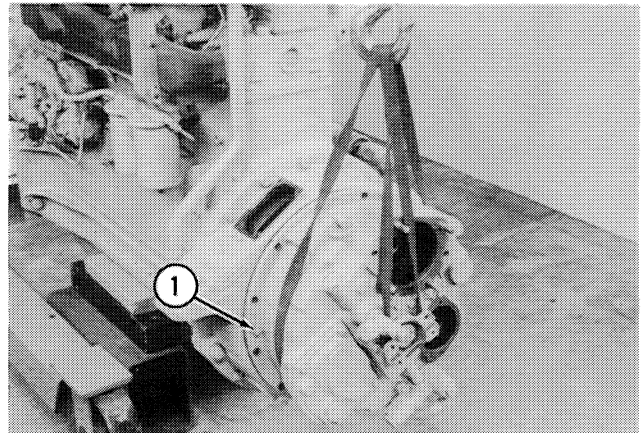

1. Cap Screw

336142

9. If the flex plates need to be replaced:

a. Make an identification mark on the outside flex plate. Use tape, paint, etc. This is necessary for the correct installation of the flex plates.

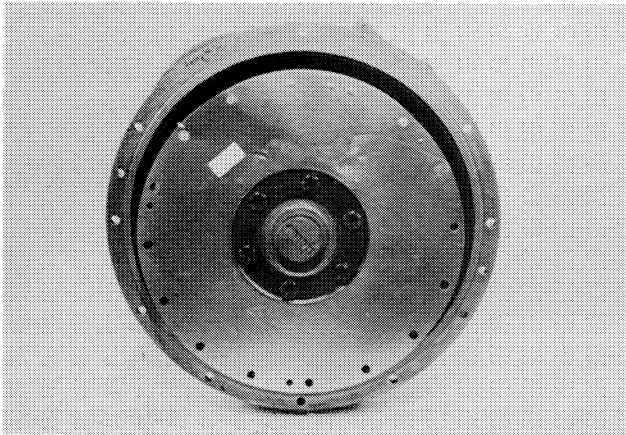

915823

b. Loosen and remove the cap screws that hold the flex plates in place.

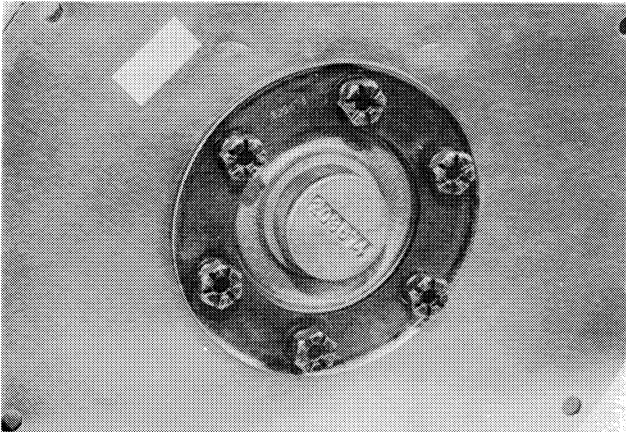

915824

c. Remove the reinforcement ring.

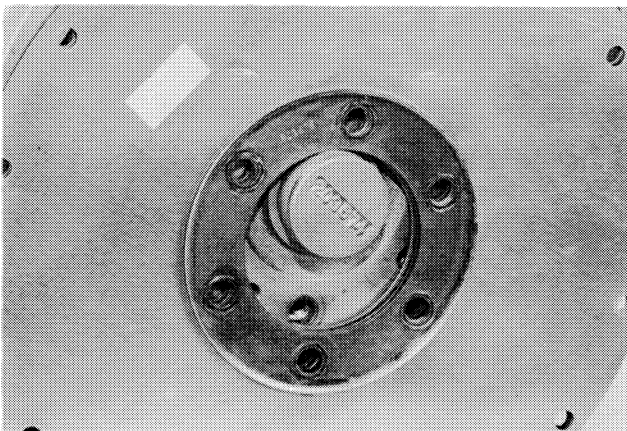

915825

d. Remove the flex plates.

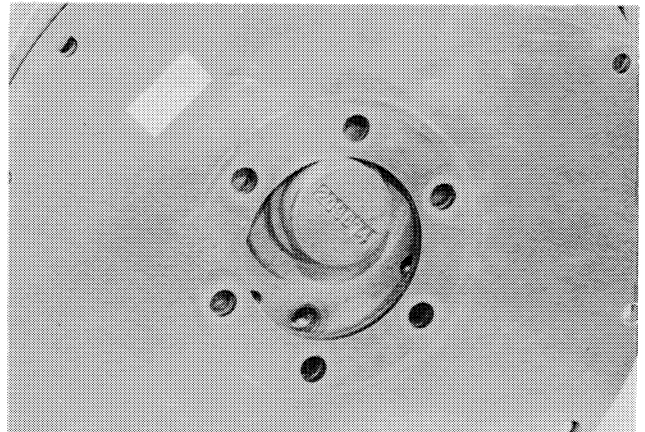

915826

e. Remove the shims.

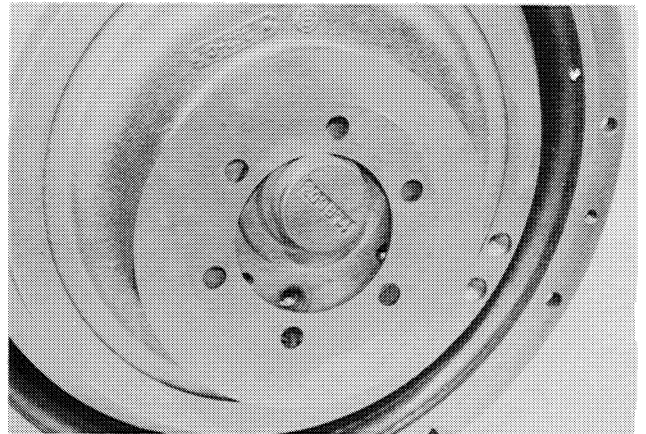

915827

10. If the flex plates were replaced:

a. Put the same number of shims on the hub as were removed during disassembly.

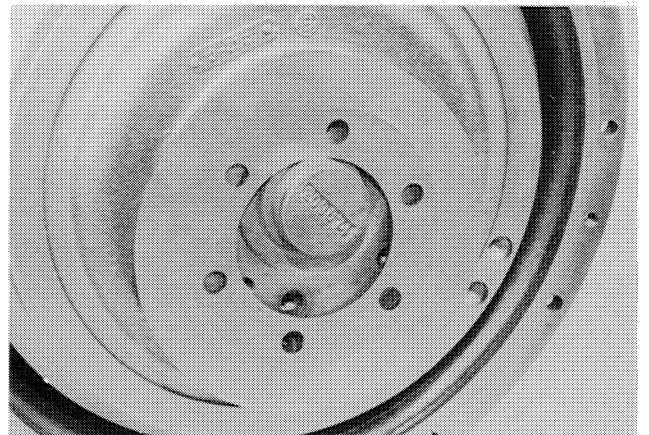

915827



**Suggest:**

**If the above button click is invalid.**

**Please download this document**

**first, and then click the above link**

**to download the complete manual.**

**Thank you so much for reading**

b. Align a new flex plate with the flex plate that has the mark. Make a mark on the same side of the new flex plate. Align the remainder of the new flex plates with the flex plate that has the mark.

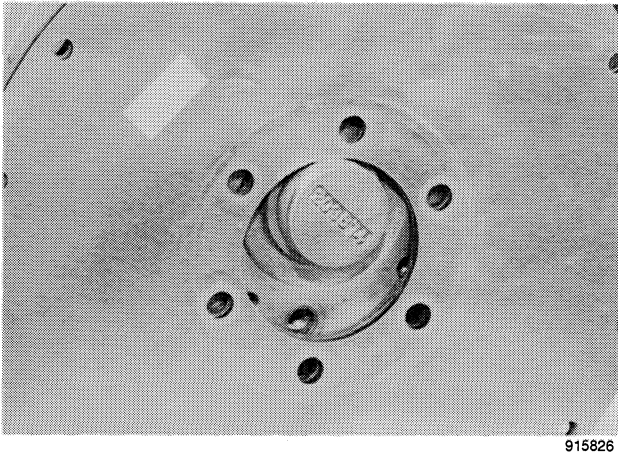

c. Install the flex plates so that the flex plate that has the mark is on the outside.

d. Put the reinforcement ring on the hub.

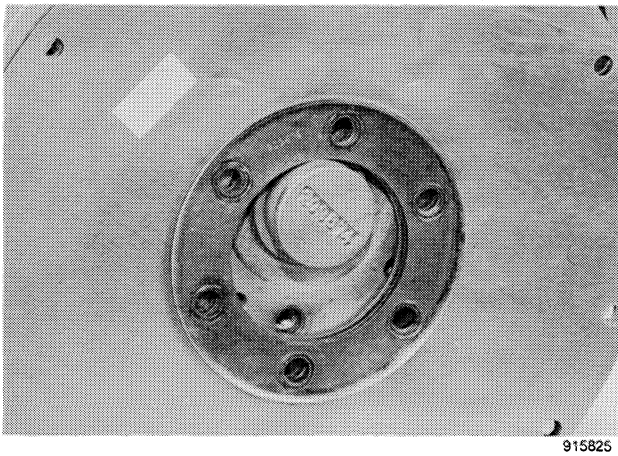

e. Install the cap screws that fasten the flex plates to the hub.

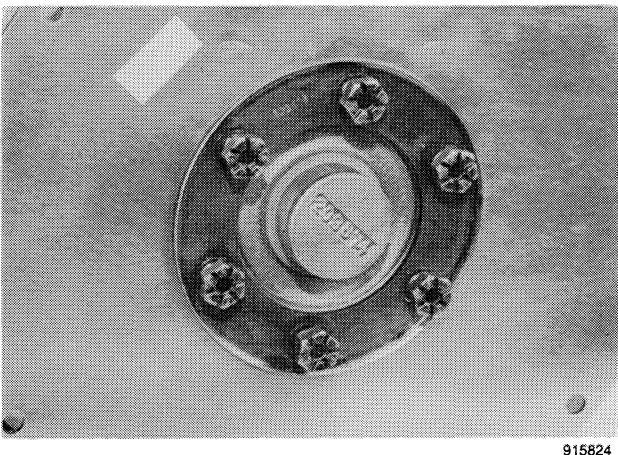

f. Use a punch to align the flex plates and tighten the cap screws.

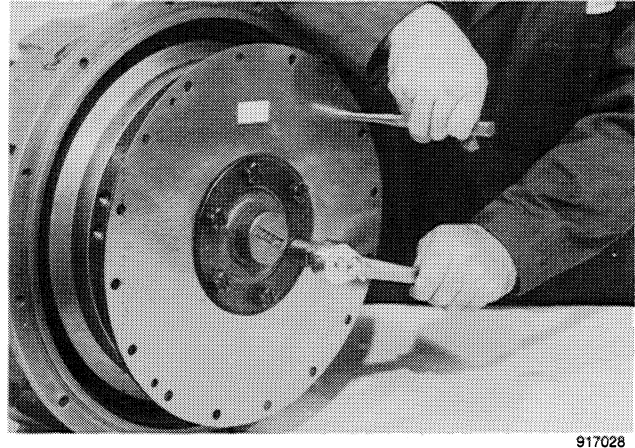

g. Tighten the cap screws that fasten the flex plates to the hub to 108 to 118 pound-feet (146 to 160 N m, 14.9 to 16.3 kg/m).

h. Measure the distance from the front of the mounting flange of the torque converter to the front of the flex plates. This distance must be  $2.180 \pm .020$  inch ( $71.4 \pm 0.5$  mm). If the distance is not as specified, add or remove shims as required.

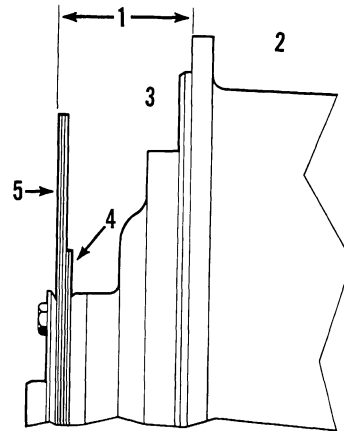

- 1.  $2.810 \pm .020$  INCHES  
( $71.4 \pm 0.5$  mm)
- 2. TORQUE CONVERTER HOUSING
- 3. TORQUE CONVERTER
- 4. SHIM(S)
- 5. FLEX PLATES

**<https://www.ebooklibonline.com>**

Hello dear friend!

Thank you very much for reading.

Enter the link into your browser.

The full manual is available for immediate download.

**<https://www.ebooklibonline.com>**