

1088 Crawler Excavator

Table of Contents

	SECTION N°	FORM N°
1. GENERAL		
Sectional Index		8-86410
Safety, General Information and Torque Specifications.....	1001 *	8-86010
Specifications.....	1002	8-86021
2. ENGINE		
Sectional Index		8-86420
Engine Removal and Installation.....	2000	8-86030
Radiator and Oil Cooler.....	2001	8-86040
Cylinder Head and Valve Train.....	2415	8-26071
Cylinder Block.....	2425	8-26082
Lubrication system.....	2445	8-26091
Cooling System.....	2455	8-26101
Turbocharger.....	2465	8-26110
Turbocharger Failure Analysis.....	2565	9-78235
3. FUEL SYSTEM		
Sectional Index		8-86430
Fuel Systems and filters.....	3410	8-26131
Fuel Injection Pump and Drive Gear.....	3412	8-26141
Fuel Injectors.....	3413	8-26150
4. ELECTRICAL		
Sectional Index		8-86440
Electrical Schematics and Troubleshooting.....	4001 *	8-86000
Battery Testing, Maintenance and Booster Battery Connections.....	4002	8-86050
Starter Motor.....	4003	8-86060
Alternator.....	4004	8-86070
5. TRACK		
Tracks, Rollers and Idlers.....	5002	8-86080
6. POWER TRAIN		
Sectional Index		8-86450
Drive Motor and Final Drive translation.....	6002	8-86090
Swing Motor and Reduction Gears.....	6003	8-86100

THIS TABLE OF CONTENTS REPLACES DON 8-86400.

8. HYDRAULICS

Sectional Index		8-86461
Pictorial Index Hydraulic Components.....	8000	7-40260
Hydraulic Troubleshooting.....	8001 *	8-85992
Low Pressure Pump.....	8002	8-86110
High Pressure Pump and Regulator.....	8003	8-86120
Attachment Valve Bank.....	8004	8-86130
Drive Control Valve.....	8005	8-86140
Option Control Valve.....	8006	8-86150
Counter Rotation Valve.....	8007	8-86970
Swing Brake Release Valve.....	8008	8-86170
Swing Control Valve.....	8009	8-86180
Anti-Surge Valve.....	8010	8-86190
Hydraulic Swivel (Standard Excavators).....	8011	8-86200
Hydraulic Swivel (Excavators with T.T.L).....	8011	7-40490
Drive Speed Limiter.....	8012	8-86210
Drive Brake Release Valve.....	8013	8-86220
Hand and Foot Control Valves.....	8015	8-86240
Hydraulic Oil Tank.....	8016	8-86250
Attachment Cylinders.....	8018	8-86270
Hydraulic Turntable Leveler Cylinder.....	8026	7-40500
Turntable Leveler Control Valve.....	8027	7-40510
Turntable Leveler Check Valve.....	8028	7-40600

9. MOUNTED EQUIPMENT

Sectional Index		8-86470
Upperstructure.....	9001	8-86311
Boom, Dipper and Bucket.....	9002	8-86290
Servicing the Cab.....	9004	8-86320

* Schematic Set Sections

REVISION NO.1
1088 CRAWLER EXCAVATOR
SERVICE MANUAL DON 8-86380

Contents of Revision

Lep 8-86401	Table of Contents
Lep 8-86021	Section 1002 - General Specifications
Lep 8-86461	Sectional Index 8
Lep 7-40260	Section 8000 - Pictorial Index
Lep 8-85992	Section 8001 - Hydraulic Schematics and Troubleshooting
Lep 7-40490	Section 8011 - Hydraulic Swivel
Lep 7-40500	Section 8026 - Hydraulic Turntable Leveler Cylinder
Lep 7-40510	Section 8027 - Turntable Leveler Cylinder
Lep 7-40600	Section 8028 - Turntable Leveler Check Valve
Lep 8-86311	Section 9001 - Upperstructure and Turntable Bearing.

Assembly Instructions

Discard the Table of Contents, Sectional Index 8, General Specifications, Hydraulic Schematics and Troubleshooting, Upperstructure and Turntable Bearing Sections. Insert the new Table of Contents 8 (Lep 8-86401), Sectional Index (Lep 8-86461) and the remaining sections of this revision into your Service Manual. Remove the Spine Label (Lep 8-86380) and replace it with the new Spine Label (Lep 8-86382).

Summary of Revision

This revision includes coverage of the 1088 Turntable Leveler Crawler Excavator.

<https://www.ebooklibonline.com>

Hello dear friend!

Thank you very much for reading.

Enter the link into your browser.

The full manual is available for immediate download.

<https://www.ebooklibonline.com>

Section 1001

SAFETY, GENERAL INFORMATION
AND TORQUE SPECIFICATIONS

1001

GENERAL INFORMATION

CLEANING

Clean all metal parts except bearings, in mineral spirits or by steam cleaning. Do not use caustic soda for steam cleaning. After cleaning dry, and put oil on all parts. Clean oil passages with compressed air. Clean bearings in kerosene, dry the bearings completely and put oil on the bearings.

INSPECTION

Check all parts when the parts are disassembled. Replace all parts that have wear or damage. Small scoring or grooves can be removed with a hone or crocus cloth. Complete visual inspection for indications of wear, pitting and the replacement of parts necessary will prevent early failures.

BEARINGS

Check bearings for easy action. If bearings have a loose fit or rough action replace the bearing. Wash bearings with a good solvent or kerosene and permit to air dry. **DO NOT DRY BEARINGS WITH COMPRESSED AIR.**

NEEDLE BEARINGS

Before you press needle bearings in a bore always remove any metal protrusions in the bore or edge of the bore. Before you press bearings into position put petroleum jelly on the inside and outside diameter of the bearings.

GEARS

Check all gears for wear and damage. Replace gears that have wear or damage.

OIL SEALS, O-RINGS AND GASKETS

Always install new oil seals, o-rings and gaskets. Put petroleum jelly on seals and o-rings.

SHAFTS

Check all shafts that have wear or damage. Check the bearing and oil seal surfaces of the shafts for damage.

SERVICE PARTS

Always install genuine Case service parts, when ordering refer to the Parts Catalog for the correct part number of the genuine Case replacement items. Failures due to the use of other than genuine Case replacement parts are not covered by warranty.

LUBRICATION

Only use the oils and lubricants specified in the Operator's or Service Manual. Failures due to the use of non specified oils and lubricants are not covered by warranty.

STANDARD TORQUE DATA FOR NUTS AND BOLTS

Where no special torque data is specified, the following torque figures should be applied. Threads should be lubricated with engine oil or chassis grease.

TORQUE SPECIFICATIONS \pm 10%									
SIZE	GRADE 8.8			GRADE 10.9			GRADE 12.9		
	lb-ft	Nm	kg/m	lb-ft	Nm	kg/m	lb-ft	Nm	kg/m
M5	4	5.5	0.56	5.5	7.5	0.76	6.6	9	0.92
M6	6.6	9	0.92	9.2	12.5	1.27	11	15	1.53
M8	16.5	22.5	2.3	23	31.5	3.2	26.5	36	3.67
M10	32	44	4.5	45	62	6.3	55	75	7.65
M12	57	77.5	7.9	81	110	11.2	95	130	13.2
M14	88	120	12.2	125	170	17.3	155	210	21.4
M16	140	190	19.4	195	265	27	236	320	32.6
M18	192	260	26.5	269	365	37.2	320	435	44.3
M20	273	370	37.7	383	520	53	457	620	63.2
M22	369	500	51	516	700	71.4	619	840	85.6
M24	471	640	65.2	665	900	92	796	1080	110
M27	702	950	97	996	1350	137.7	1195	1620	165.2
M30	955	1300	132.5	1328	1800	183.6	1593	2160	220.3

TORQUE DATA FOR HYDRAULIC FITTINGS

UNIONS, CONNECTIONS AND PLUGS

Diameter x Pitch	Newton / Metres	Pounds / Feet	Kilogram / Metres
M10 x 1	20	14.5	2
M12 x 1.5	35	26	3.6
M14 x 1.5	45	33.2	4.6
M16 x 1.5	60	44	6.1
M18 x 1.5	70	51	7.1
M22 x 1.5	100	73	10.2
M27 x 2	200	147	20.4
M33 x 2	280	207	28.6
M42 x 2	380	281	38.8

NUTS FOR PIPES AND HOSES

Diameter x Pitch	Newton / Metres	Pounds / Feet	Kilogram / Metres
M16 x 1.5	20	14.5	2
M18 x 1.5	35	26	3.6
M20 x 1.45	45	33.2	4.6
M24 x 1.5	60	44	6.1

FLANGES

Diameter x Pitch	Newton / Metres	Pounds / Feet	Kilogram / Metres
M8 x 1.5	28	21	2.9
M10 x 1.5	55	41	5.6
M12 x 1.75	90	67	9.2
M14 x 2	145	107	14.8
M16 x 2	230	170	23.5

MODEL AND PIN NUMBERS

When ordering parts or when requesting information or assistance, always give the identification numbers of your machine.

Write the model and PIN numbers of your machine on the lines below.

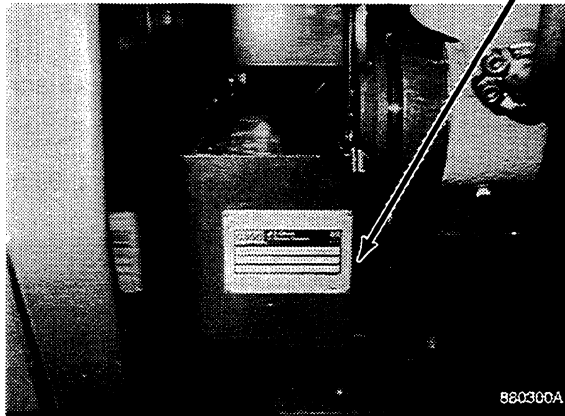

Machine Model Number _____

Machine PIN Number _____

Engine Serial Number _____

High Pressure Pump Serial Number _____

Low Pressure Pump Serial Number _____

Final Drive Serial Number:

Right Hand Side _____

Left Hand Side _____

Section 2000

ENGINE REMOVAL AND INSTALLATION

For 1088 Crawler Excavators

2000

TABLE OF CONTENTS

SPECIAL TORQUES	2
SPECIAL TOOLS	2
ENGINE	
Removal	3
Installation	9



WARNING: This safety symbol is used in this manual to indicate important safety messages. When you see this symbol, read the message carefully. It is shown when possible injury or death can be caused.

SPECIAL TORQUES

Engine Mounting Bolts	217 to 271 Nm	160 to 200 lb ft
Fan Mounting Bolts	43 Nm	32 lb ft
Hydraulic Pump Mounting Bolts	44 Nm	32.5 lb ft
Shock-Absorber Centering-Mount Bolts	220 Nm	162 lb ft

SPECIAL TOOLS

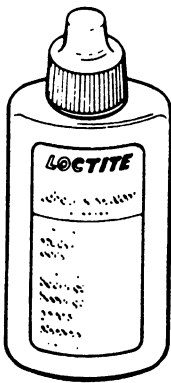

1. LOCTITE 638
CASE PART NUMBER P1003572

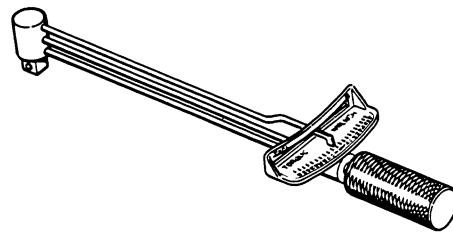

2. TORQUE WRENCH (Nm or lb ft)

Removal



WARNING: When the machine is operating, the engine systems and the hydraulic pump systems heat up to a high temperature. To avoid the possibility of being burnt by hot metal or scalded by hot oil or water, allow the machine to cool before starting any maintenance work.

STEP 1

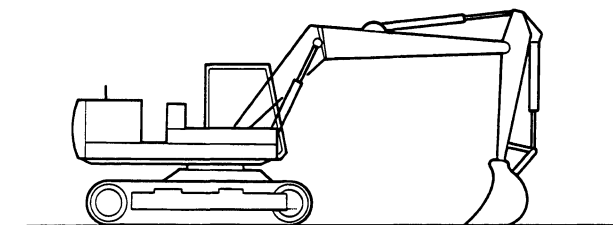

EA2836

Put the machine on level ground. Lower the attachment to the ground. Stop the engine and allow the systems to cool.

STEP 2



Raise the engine upper access cover and install the support rod.
Lift and remove the engine front cover.

STEP 3

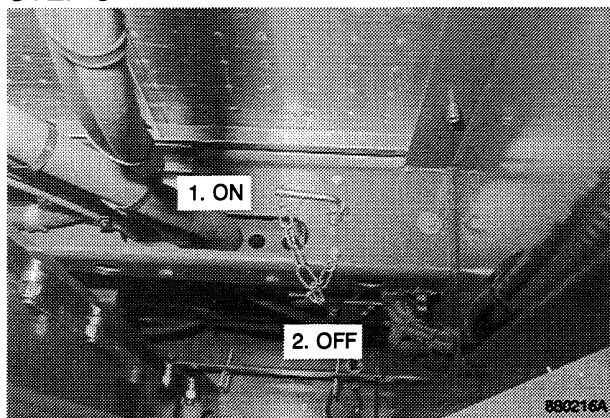

Turn the master disconnect switch, located under the left hand side of the walkway, to the OFF position and remove the key.

STEP 4

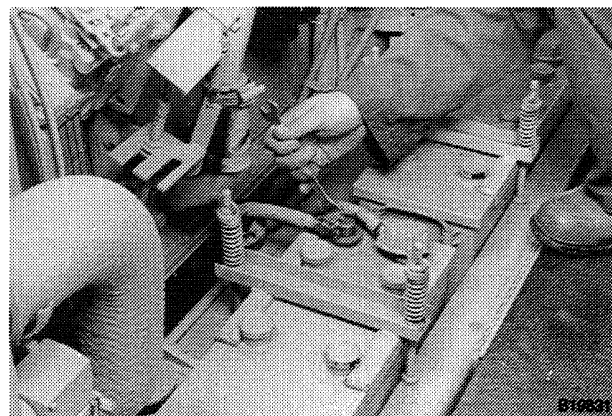

Remove the battery cover.
Disconnect the negative (-) cable first as shown.
Disconnect the remaining cables.
Remove the battery securing clamps and remove the batteries.

STEP 5

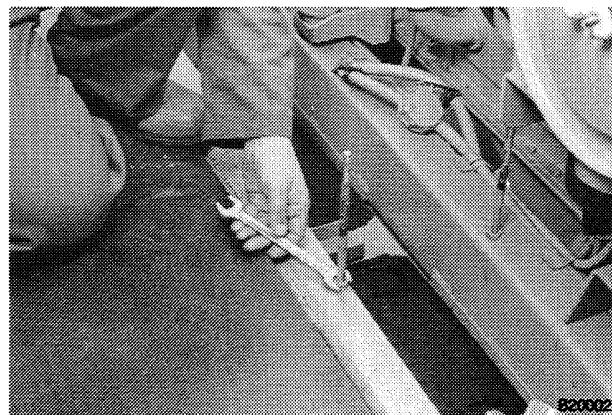

For safety, remove the battery securing bolts and nuts.

STEP 6

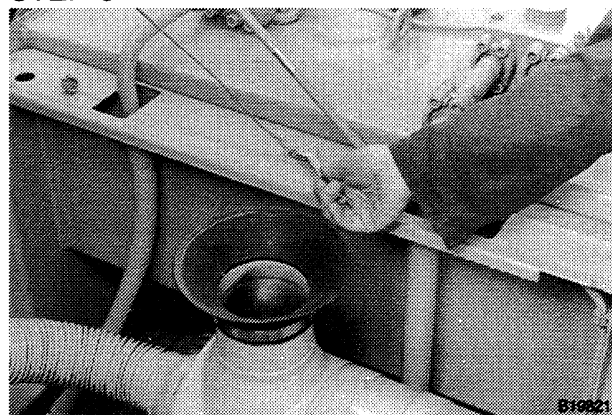

Remove the bolt, spacers and nut securing the engine upper access cover safety cable. Close the cover.

STEP 7

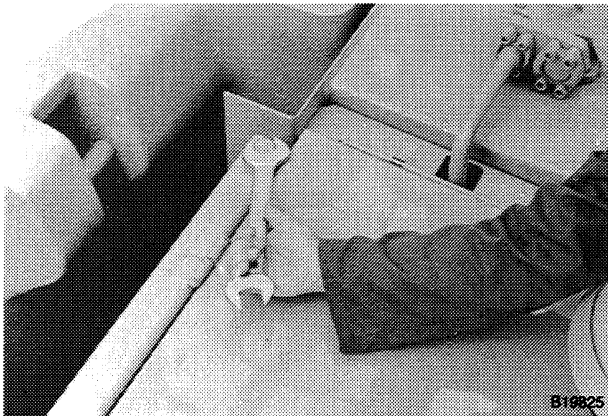

Remove the bolts, spacers and nuts securing the upper access cover. Lift and remove the cover.

STEP 8

Remove the access panel under the engine.

STEP 9

Remove the access panels under the radiator and under the hydraulic oil tank.

STEP 10

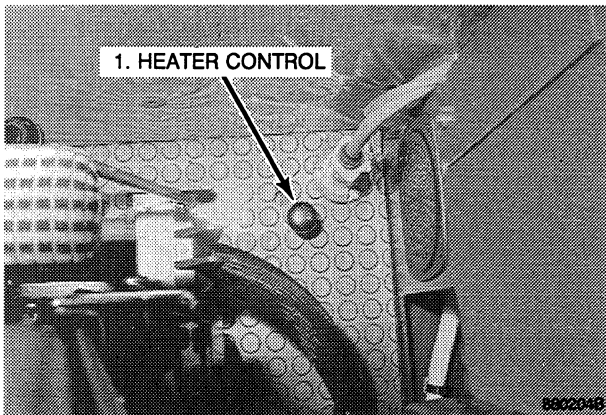

Pull up the heater control in the cab to prevent the unnecessary draining of the cab heating system.

 *Hot coolant can spray out if the radiator cap is removed. To remove the radiator cap, let the cooling system cool, turn to the first notch, and wait until the pressure is released. Then, remove the radiator cap.*

STEP 11

Remove the radiator cap.
Place a clean container of at least 20 litres (5½ US gallons) capacity under the radiator.

STEP 12

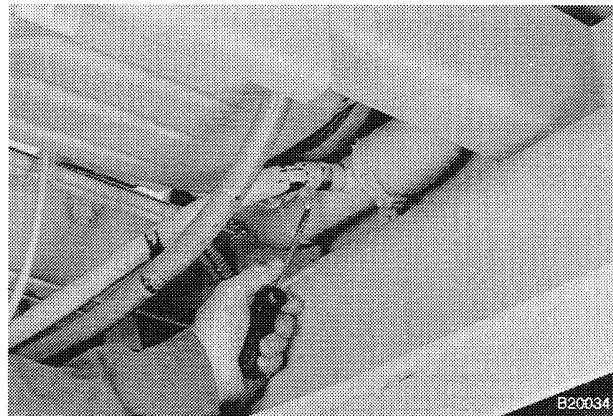

Disconnect the cab heater hose from the engine coolant tube and drain the engine coolant into the container.

STEP 13

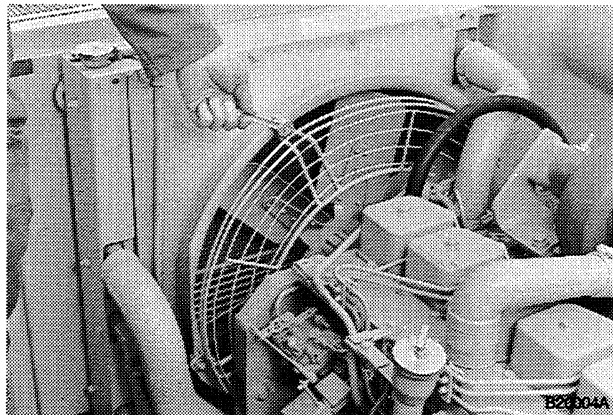

Remove the fan guard securing bolts, spacers and nuts. Remove the fan guard.

STEP 14

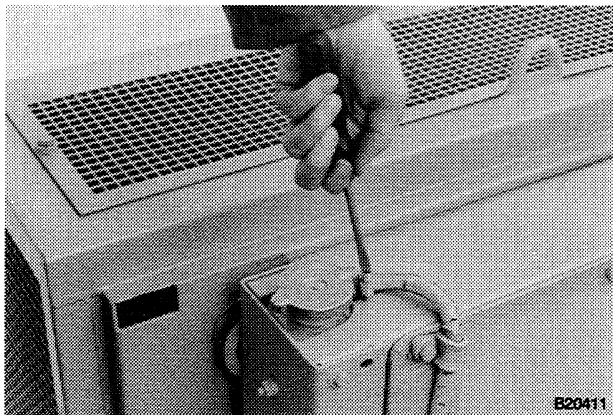

Disconnect the engine coolant recovery hose from the radiator and fan shroud.

STEP 15

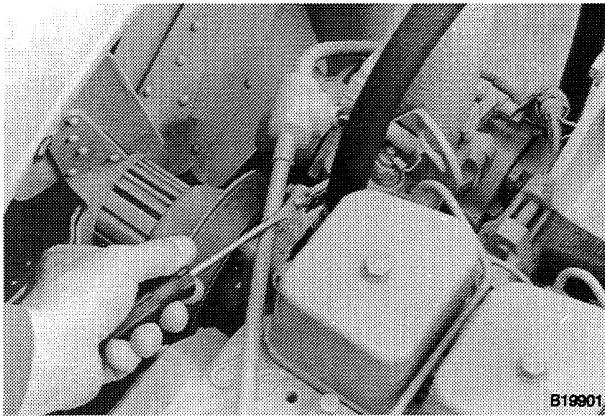

Disconnect the cab heater hose from the engine.

STEP 18

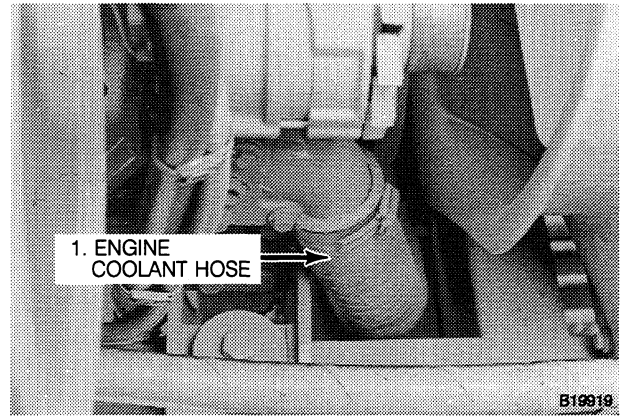

Disconnect the engine coolant hose from the engine.

STEP 16

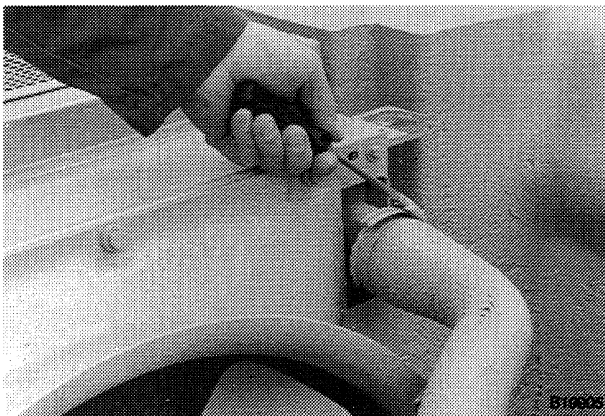

Disconnect the upper radiator hose from the radiator and the engine.

STEP 19

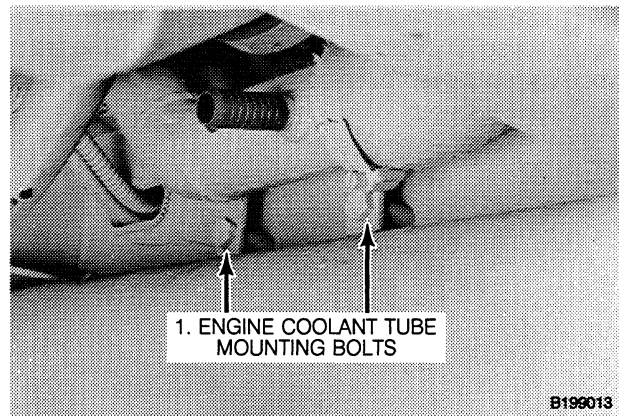

Remove the engine coolant tube mounting bolts, spacers and nuts. Remove the tube complete with hoses attached at both ends.

STEP 17

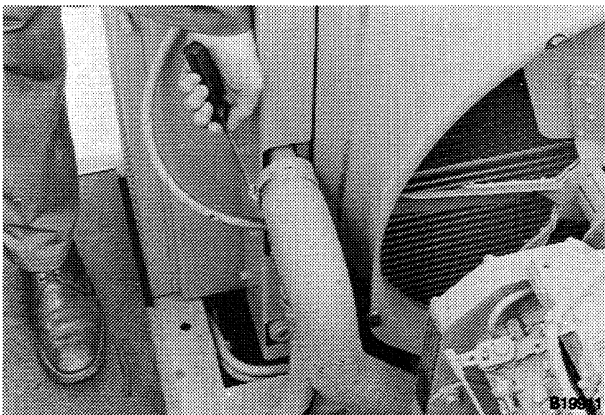

Disconnect the lower radiator hose from the radiator.

STEP 20

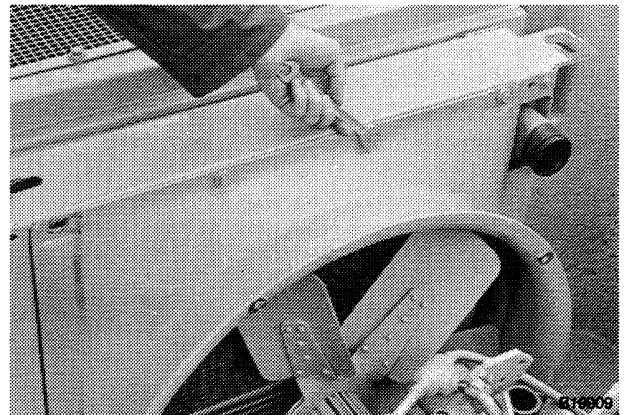

Remove the fan shroud mounting bolts and spacers.

STEP 21

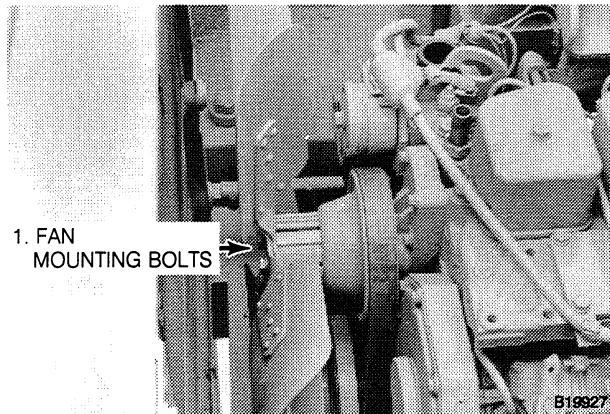

Remove the fan mounting bolts and spacers. Remove the fan, the fan spacer and the fan shroud.

NOTE: *The fan shroud in the photograph above has been removed for photographic purposes only. The fan shroud cannot be removed until the fan and fan spacer have been removed.*

STEP 22

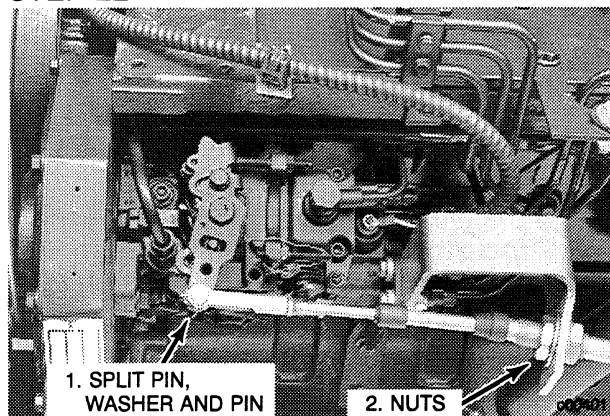

Remove the split pin, washer and pin that hold the throttle cable onto the fuel injection pump lever. Loosen the nuts that hold the throttle cable in the bracket and remove the throttle cable from the engine.

STEP 23

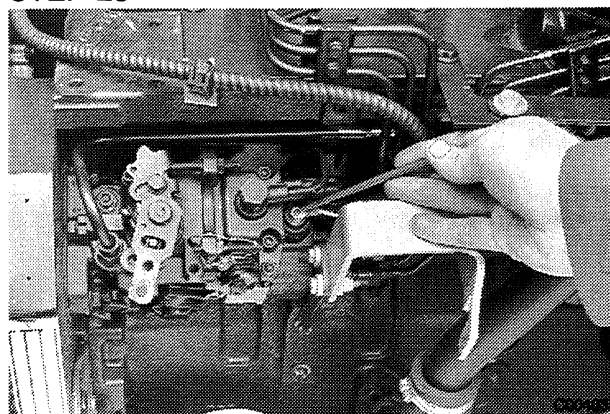

Disconnect the engine shut-down wire from the fuel injection pump.

STEP 24

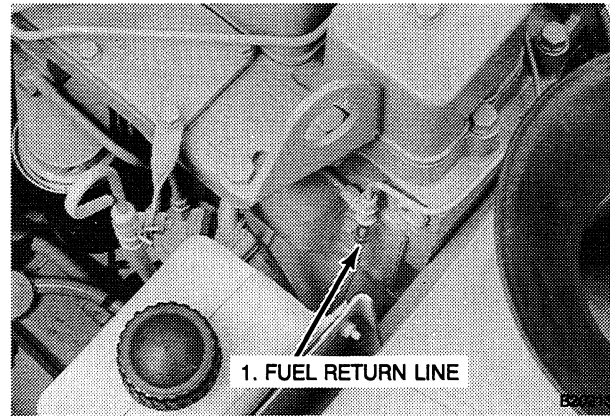

Disconnect the fuel return line from the engine. Disconnect and cap the fuel return line from the tee assembly.

STEP 25

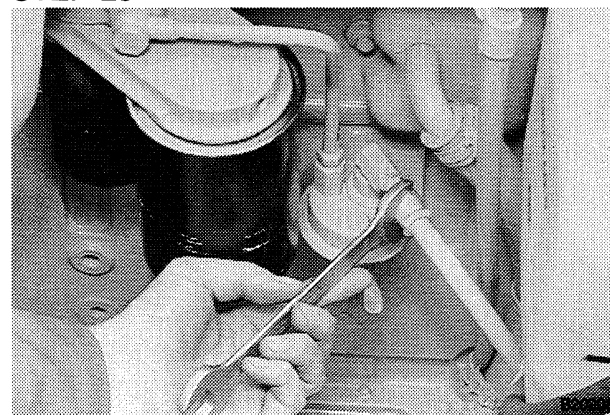

Disconnect and cap the fuel supply line from the fuel lift pump.

STEP 26

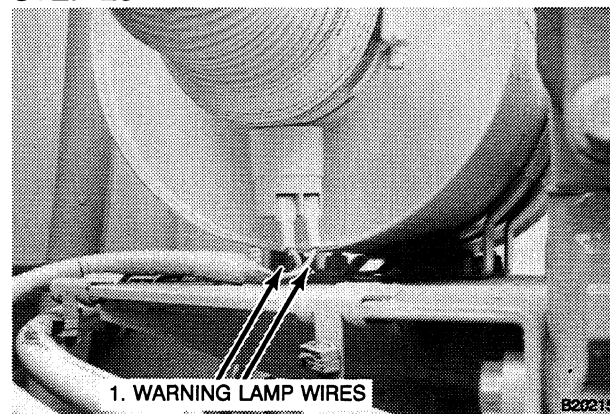

Label and disconnect the air filter warning lamp wires from the air filter.

STEP 27

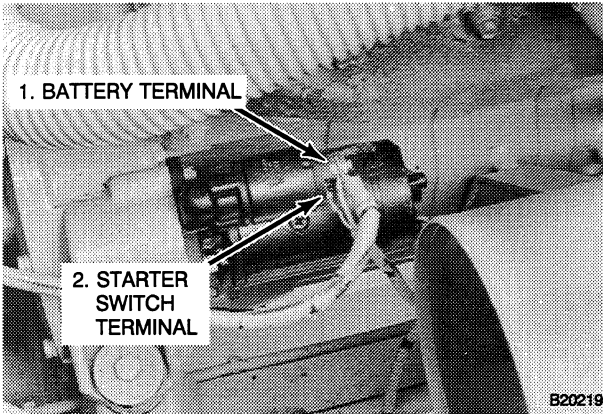

Remove the nut and washer and remove the battery cable and wire number 2 from the battery terminal. Remove the screw and washer and remove wire number 4 from the starter switch terminal.

STEP 28

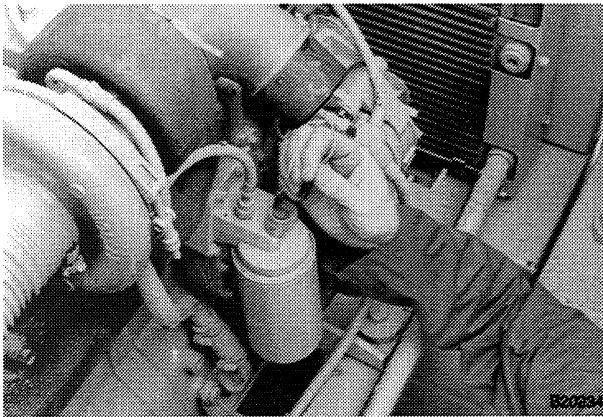

Disconnect the oil pressure warning switch.

STEP 29

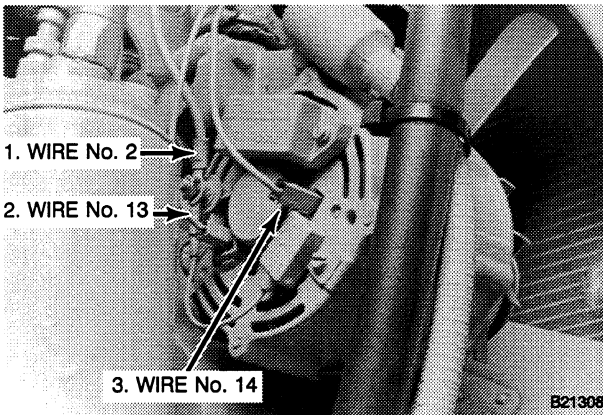

Remove the nut and remove wire number 2 from the B+ terminal on the alternator. Remove wire number 13 from the D+ terminal. Remove wire number 14 from the W terminal.

STEP 30

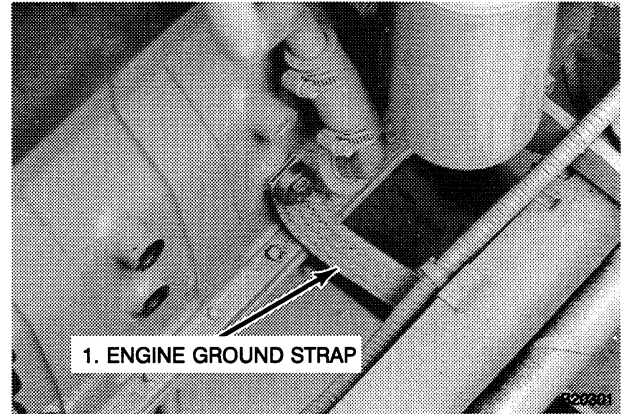

Disconnect the engine ground strap from the engine.

STEP 31

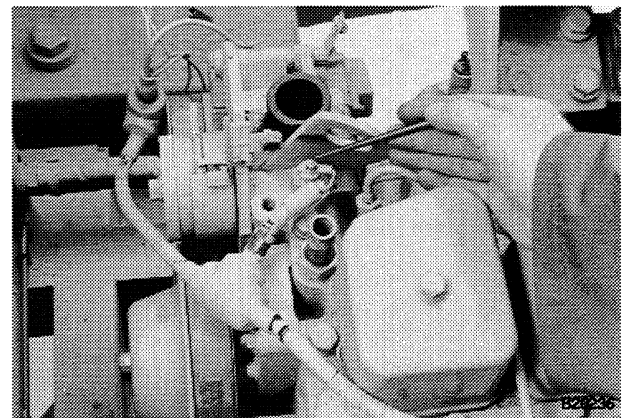

Disconnect the water temperature gauge wire.

STEP 32

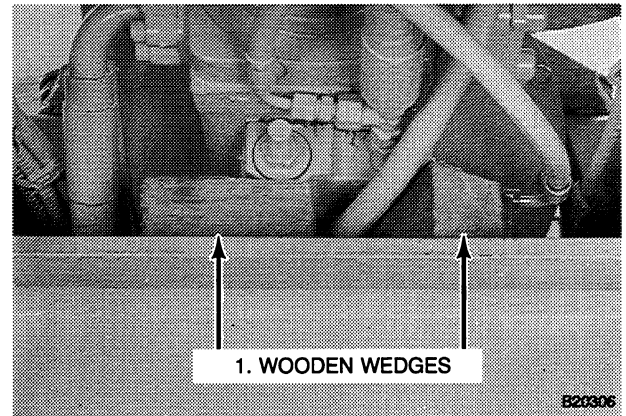

Position wooden wedges under the hydraulic pump to prevent the pump falling when the engine is removed.

STEP 33

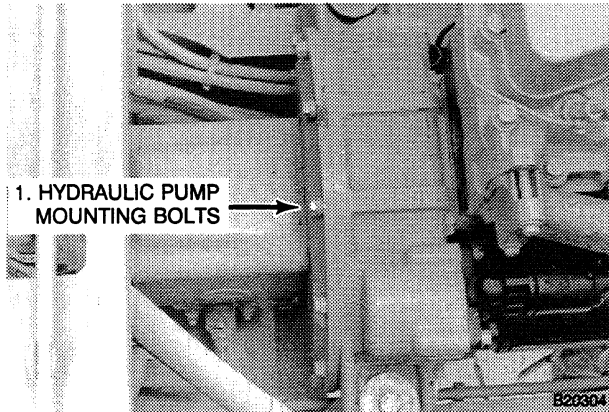

Remove the hydraulic pump mounting bolts and spacers.

STEP 34

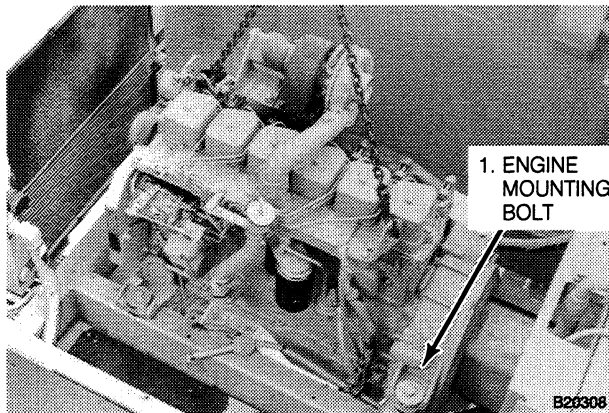

Connect the engine to a hoist using the lifting eyes installed on the engine. Remove the engine mounting bolts, washers, spacers and nuts.

NOTE: *The engine weighs approximately 512 kg (1130 lb).*

STEP 35

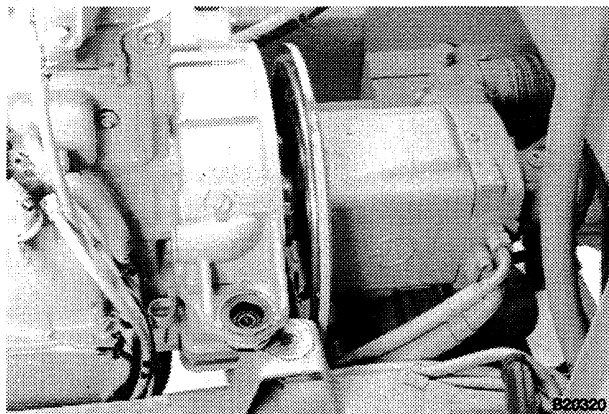

Lift the engine free of the mountings and move towards the radiator until it is free from the hydraulic pump coupling. Carefully remove the engine from the machine.

STEP 36

1. UPPER RUBBER INSULATOR

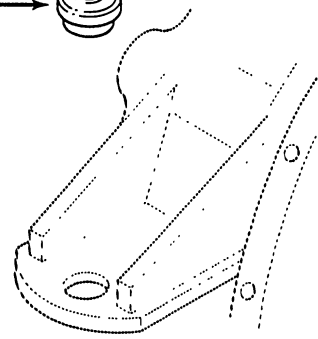

2. LOWER RUBBER INSULATOR



0216S

Inspect the rubber insulators for wear or damage and replace if necessary.

STEP 37

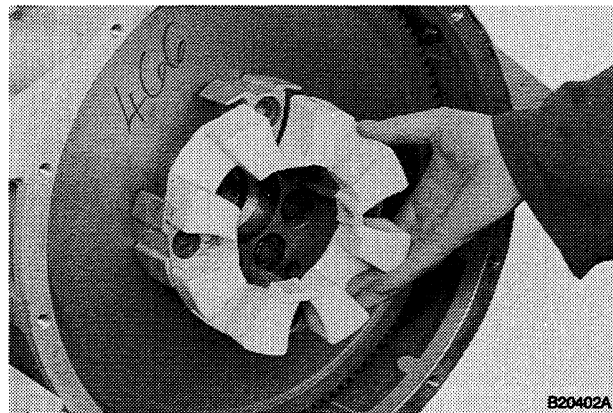

Inspect the hydraulic pump shock absorber for wear or damage and replace if necessary.

STEP 38

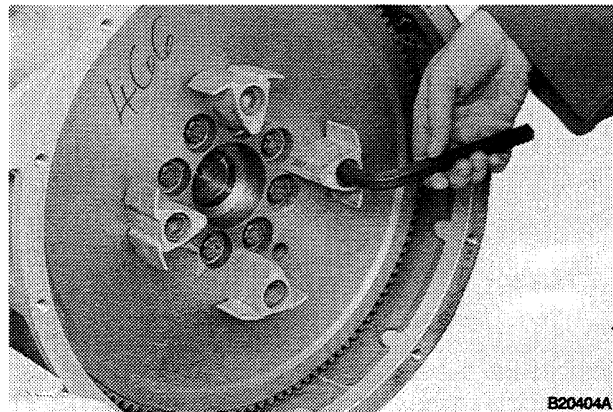

Remove the shock-absorber centering-mount bolts and remove the shock-absorber centering-mounts. Inspect the shock-absorber centering-mounts for wear or damage and replace if necessary.

Installation

STEP 39

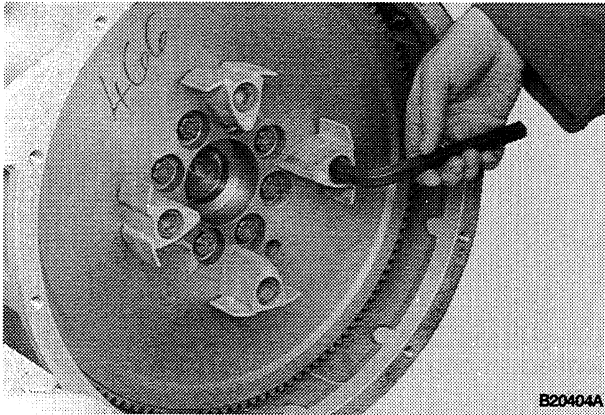

Clean the shock-absorber centering-mount bolts and bolt holes. Apply Loctite 638 to the shock-absorber centering-mount bolts. Install the shock-absorber centering-mounts and bolts. Do not fully tighten the bolts.

STEP 40

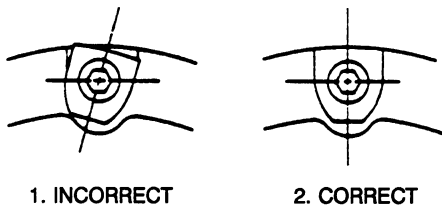
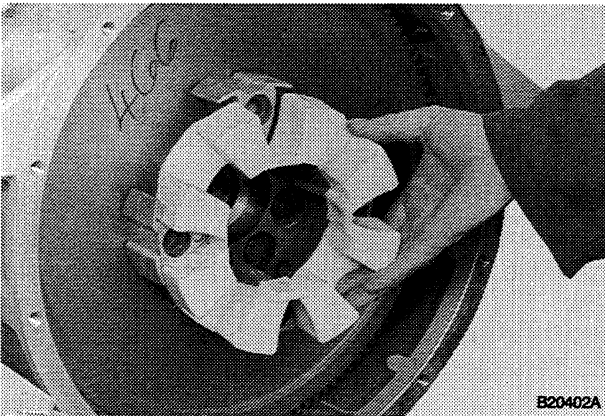

Install the shock-absorber. Make sure that the shock-absorber centering-mounts are centered in the shock-absorber and tighten the bolts to a torque of 220 Nm (162 lb ft).

STEP 41

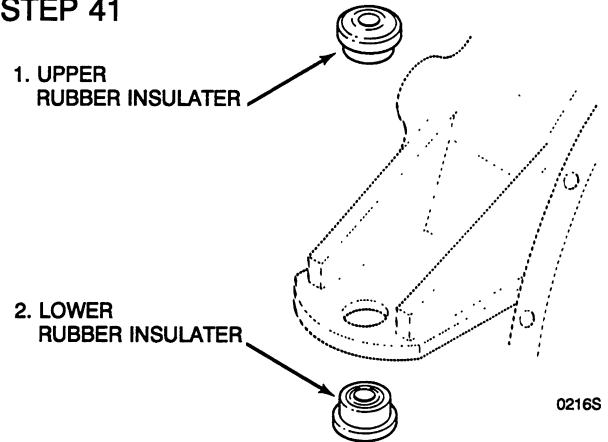

Install the upper and lower rubber insulators. The insulators are a tight fit in the engine supports.

STEP 42

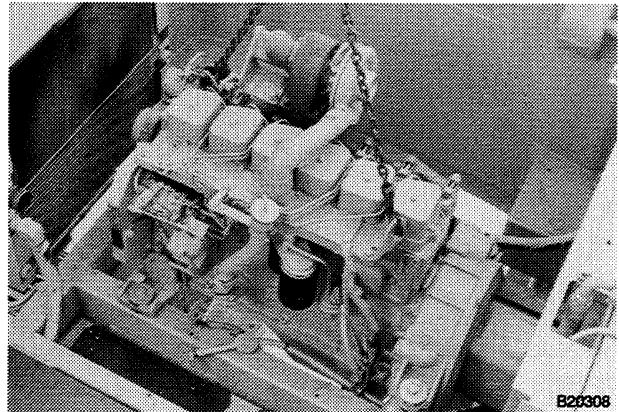

Connect the engine to the hydraulic pump, making sure that the hydraulic pump drive coupling engages correctly.

STEP 43

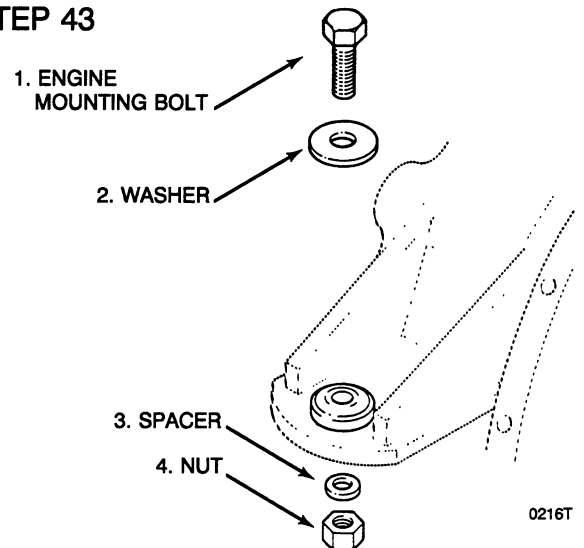

Install the engine mounting bolts, washers, spacers and nuts. Tighten the engine mounting bolts to a torque of 217 to 271 Nm (160 to 200 lb ft).

STEP 44

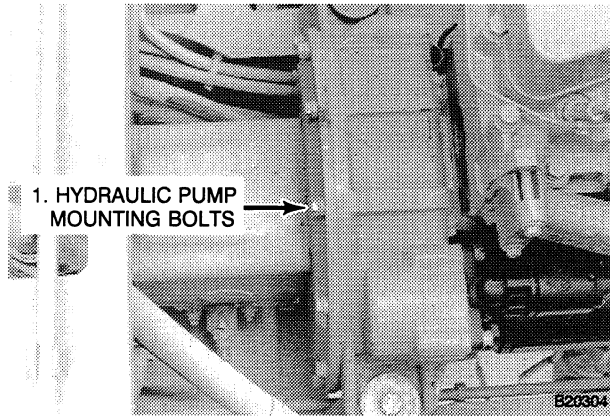

Install and tighten the hydraulic pump mounting bolts and spacers to a torque of 44 Nm (32.5 lb ft).

STEP 45

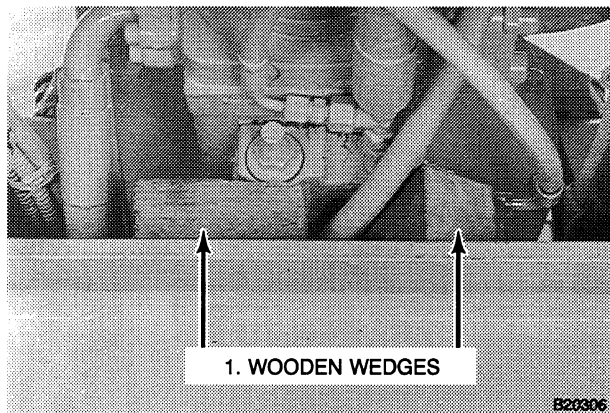

Remove the wooden wedges under the hydraulic pump.

STEP 46

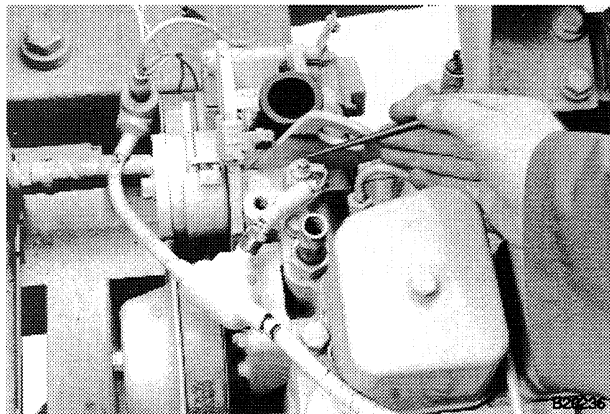

Connect the water temperature gauge wire to the engine.

STEP 47

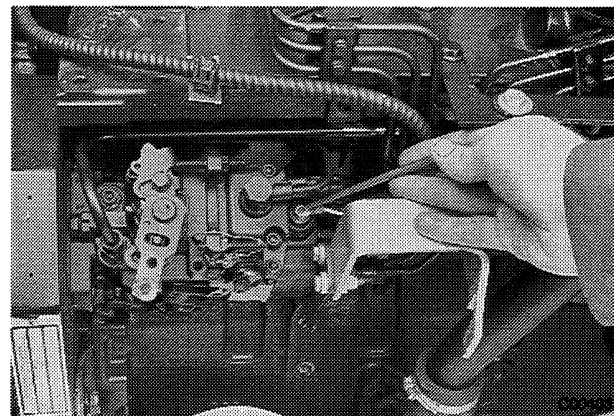

Connect the engine shut-down wire to the fuel injection pump.

STEP 48

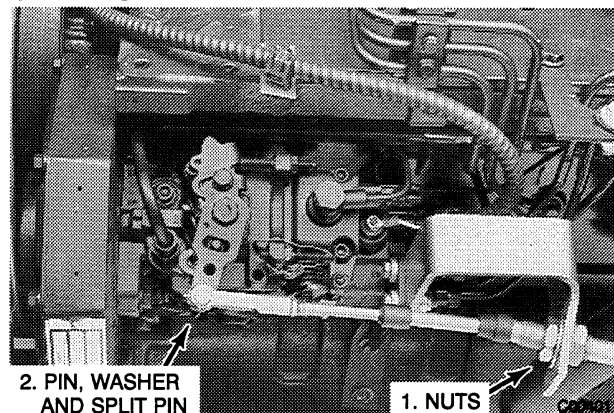

Install the throttle cable in the bracket and tighten the nuts.

Install the pin, washer and split pin connecting the throttle cable to the fuel injection pump lever.

STEP 49

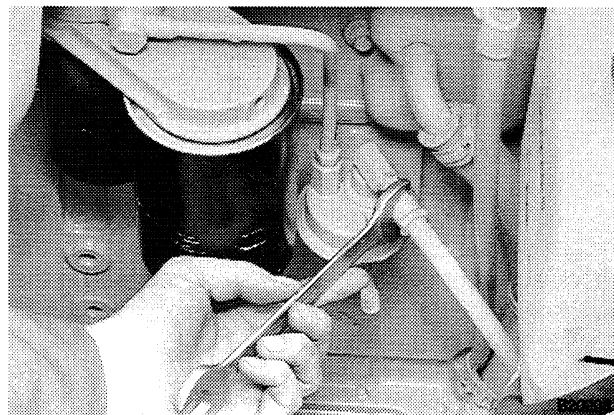

Remove the cap and connect the fuel supply line to the fuel lift pump.

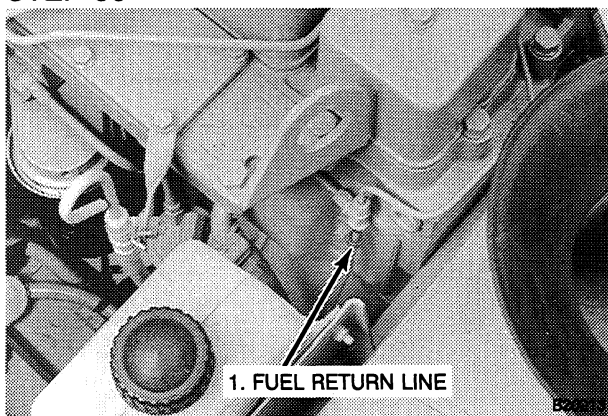
STEP 50

Remove the cap and connect the fuel return line to the tee assembly and then to the engine.

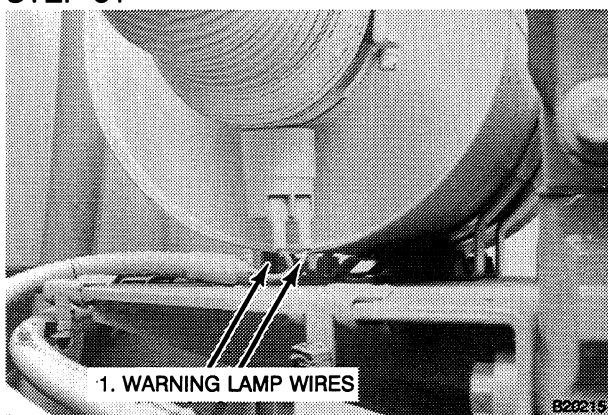
STEP 51

Connect the air filter warning lamp wires to the air filter.

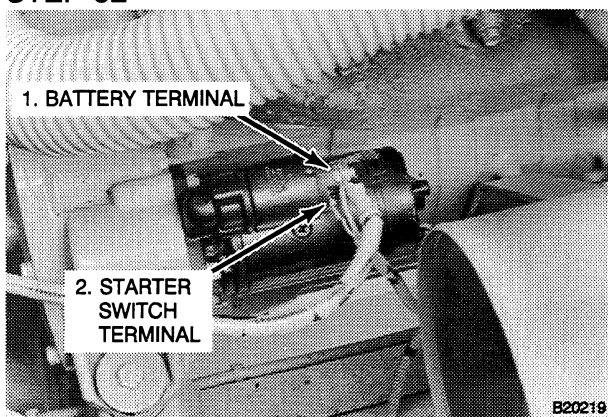
STEP 52

Install the battery cable and wire number 2 on the battery terminal. Install and tighten the washer and nut. Install wire number 4 on the starter switch terminal. Install and tighten the washer and screw.

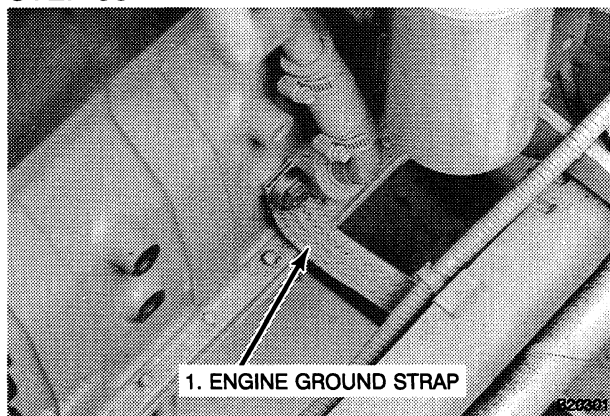
STEP 53

Connect the engine ground strap to the engine.

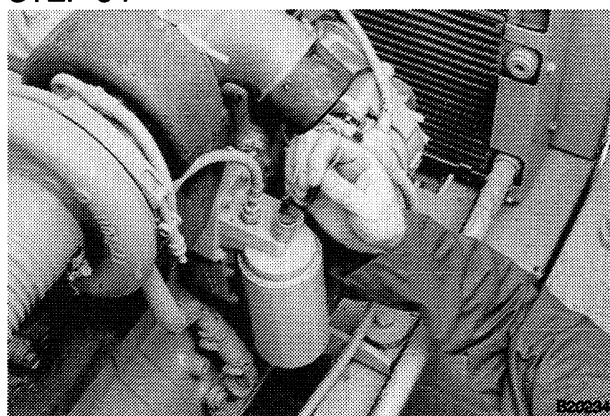
STEP 54

Connect the oil pressure warning lamp wires to the oil filter.

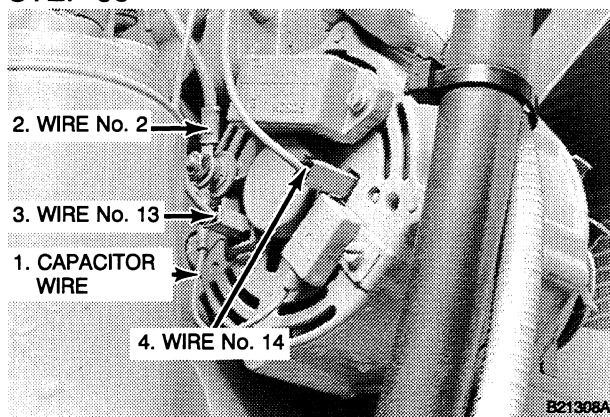
STEP 55

Make sure the capacitor wire is installed on the B+ terminal. Install wire number 2 on the B+ terminal and install and tighten the nut. Connect wire number 13 to the D+ terminal. Connect wire number 14 to the W terminal.

STEP 56

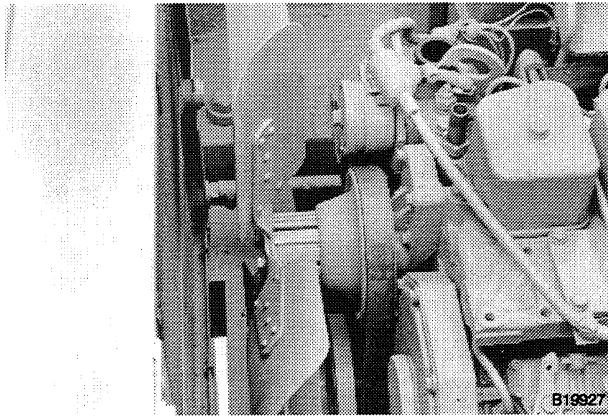

Install the fan shroud, fan spacer and fan. Install the fan mounting bolts and spacers. Tighten the bolts to a torque of 43 Nm (32 lb ft).

NOTE: *The fan shroud is removed from the above photograph for photographic purposes only. Install the fan shroud before the fan spacer and fan are installed.*

STEP 57

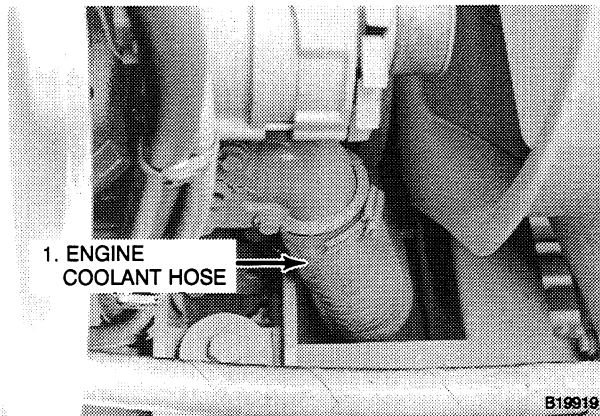

Connect the engine coolant hose to the engine and tighten the clamp.

STEP 58

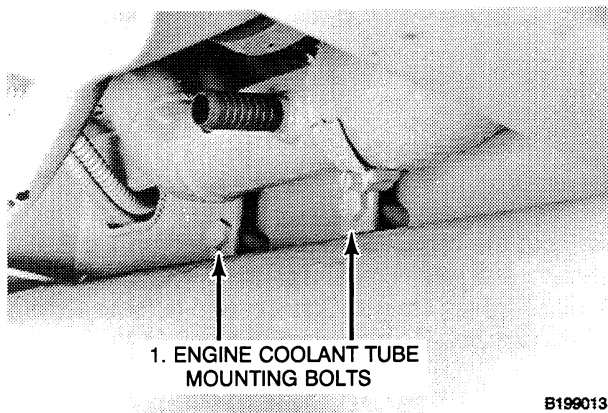

Install the engine coolant tube. Install and tighten the mounting bolts, spacers and nuts.

STEP 59

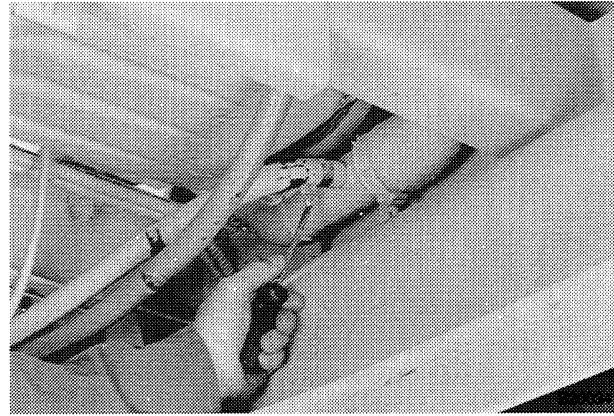

Connect the cab heater hose to the engine coolant tube. Tighten the clamp.

STEP 60

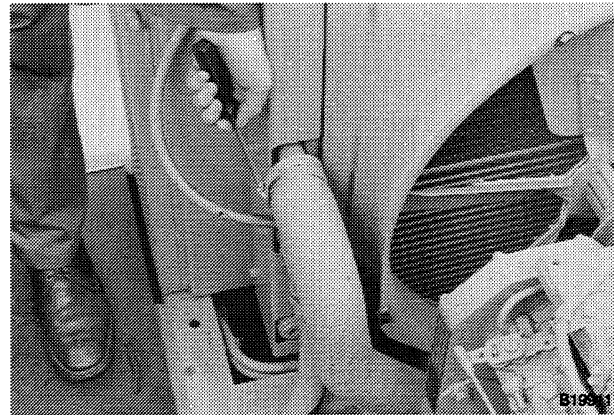

Connect the lower radiator hose to the radiator and tighten the clamp.

STEP 61

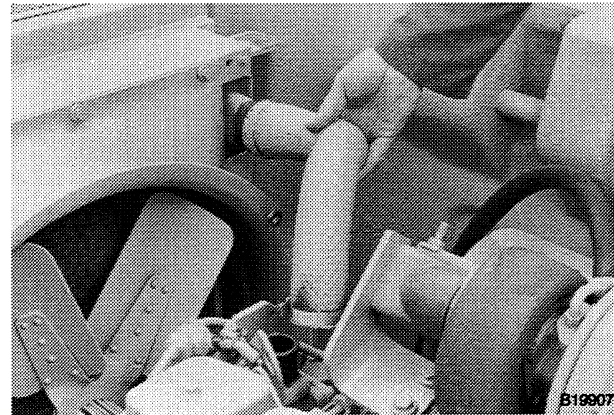

Connect the upper radiator hose to the radiator and the engine and tighten the clamps.

STEP 62

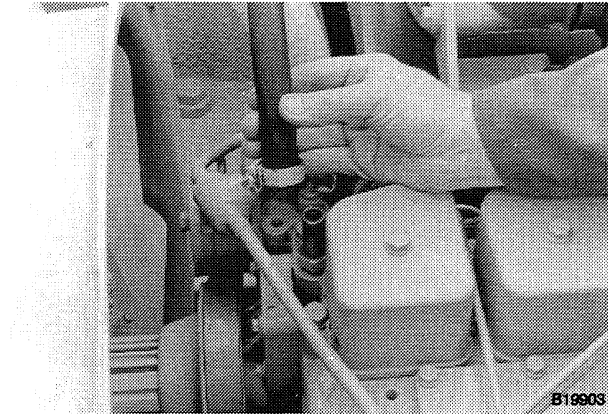

Connect the cab heater hose to the engine and tighten the clamp.

STEP 63

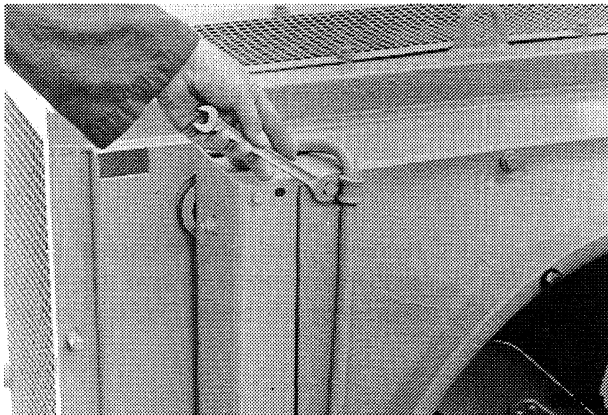

Connect the engine coolant recovery hose to the fan shroud and the radiator.

STEP 64

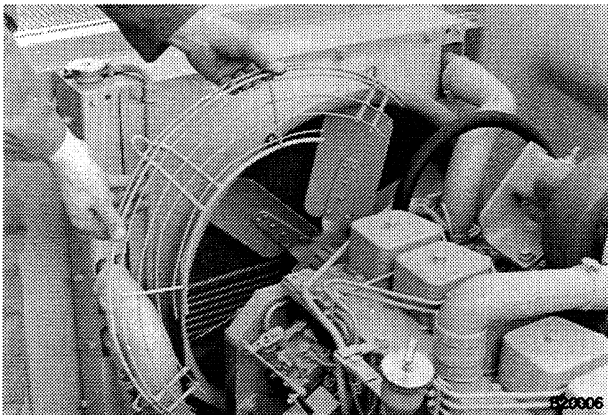

Install the fan guard. Install and tighten the mounting bolts, spacers and nuts.

STEP 65

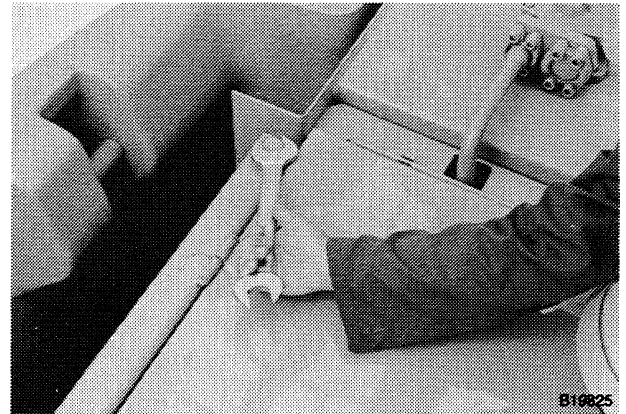

Install the engine upper access cover. Install and tighten the mounting bolts, spacers and nuts. Raise the cover and install the support rod.

STEP 66

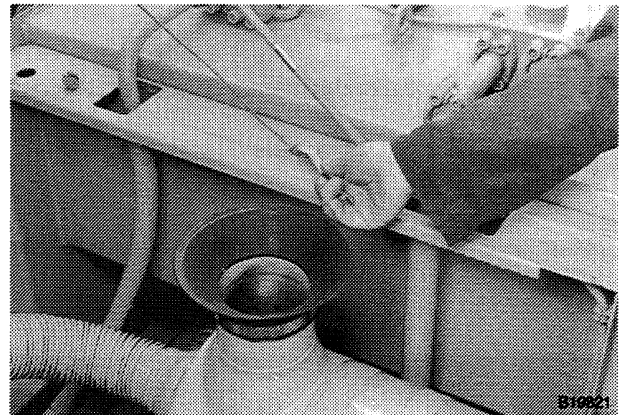

Install and tighten the safety cable securing bolt, spacers and nut.

STEP 67

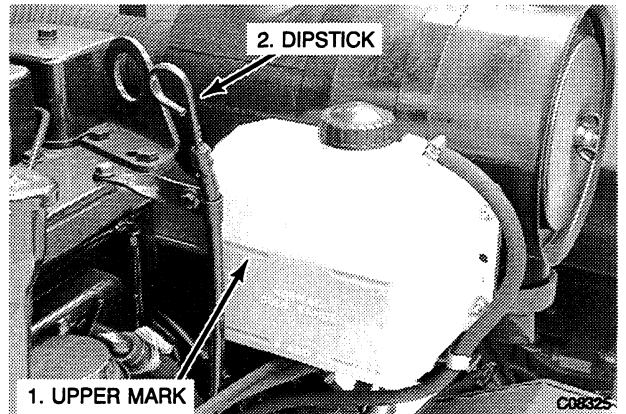

Fill the radiator with specified engine coolant. Install the radiator cap. Fill the coolant recovery bottle with specified engine coolant up to the upper mark. Install the bottle cap.

Fill the engine with specified engine oil up to the FULL mark on the engine oil dipstick.

STEP 68

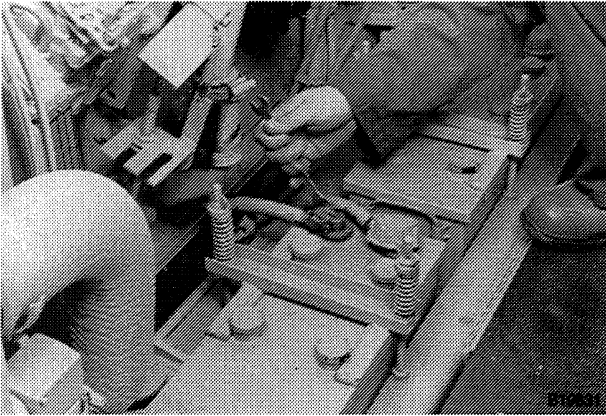

Install the battery securing bolts and nuts. Install the batteries and install and tighten the battery securing clamps. Connecting the negative (-) cable last, connect the battery cables. Install the battery cover

STEP 69

Install the key and turn the master disconnect switch to the ON position.

STEP 70

Remove air from the fuel system. Refer to Section 3410.

 **WARNING:** *Never operate the engine in a closed building. Proper ventilation is required under all circumstances.*

STEP 71

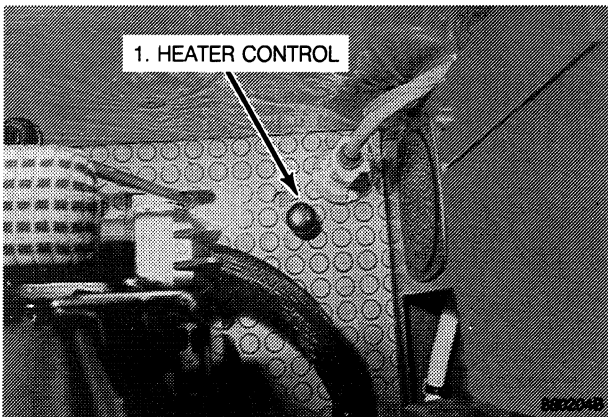

Push down the heater control in the cab to allow circulation of the engine coolant and to allow trapped air to collect at the air bleed screw. Start and run the engine for 5 minutes. Stop the engine.

 **WARNING:** *Hot coolant will spray out of the air bleed screw. To avoid injury, care must be taken when removing air from the cooling system.*

STEP 72

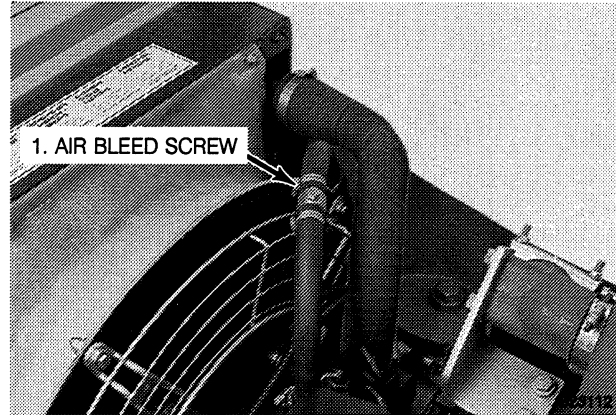

Open the air bleed screw until there is a flow of coolant without bubbles. Tighten the air bleed screw.

STEP 73

Check for and repair any fuel, engine coolant and oil leaks. Check the level of engine oil and the level of engine coolant in the recovery bottle. Top up the levels as required.

STEP 74

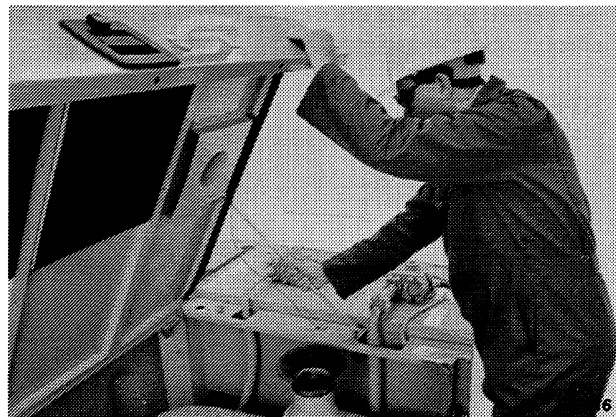

Install the engine front cover. Close the engine upper access cover. Install the access panels under the engine, radiator and hydraulic oil tank.

Section 2001

RADIATOR AND OIL COOLER

For 1088 Crawler Excavators

2001

TABLE OF CONTENTS

SPECIFICATIONS	2
SPECIAL TORQUES.....	2
SPECIAL TOOLS	2
RADIATOR AND OIL COOLER	
Removal	3
Installation	6

SPECIFICATIONS

Coolant Solution	50% Ethylene Glycol / Water Solution
Coolant Capacity.....	19.2 Litres 5.07 US Gallons
Thermostat	82 to 94°C 180 to 220°F
Radiator Cap.....	1.03 Bar 15 psi

IMPORTANT: *When using ethylene glycol coolant solutions, always have a minimum of 50 percent ethylene glycol coolant in the system. Do not put more than 50 percent ethylene glycol in the cooling system unless the ambient air temperature will be less than -36°C (- 34°F). More than 50 percent decreases heat transfer and will cause the engine surface temperature to be higher than normal.*



WARNING: *This safety symbol is used in this manual to indicate important safety messages. When you see this symbol, read the message carefully. It is shown when possible injury or death can be caused.*

SPECIAL TORQUES

Lower Radiator Mounting Bolts	44 Nm	32.5 lb ft
Fan Mounting Bolts.....	43 Nm	32 lb ft

SPECIAL TOOLS

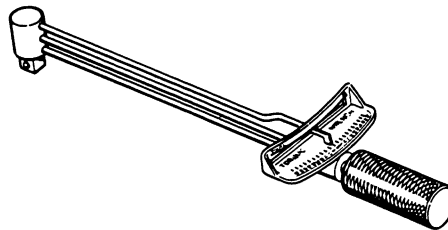

1. TORQUE WRENCH

Removal

STEP 1

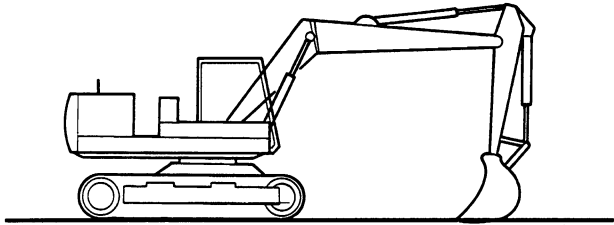

EA2836

Put the machine on level ground. Lower the attachment to the ground. Stop the engine.

STEP 2

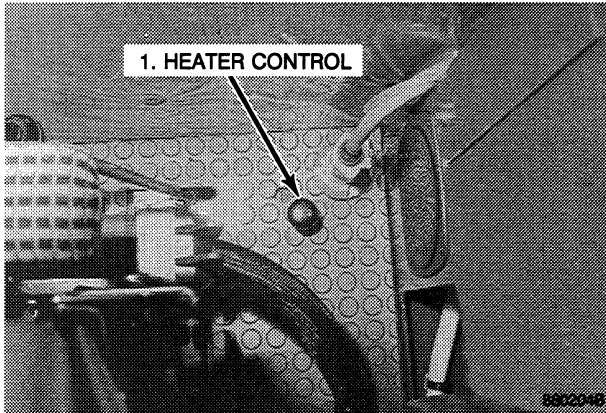

5002048

Pull up the heater control in the cab to prevent unnecessary draining of engine coolant.

STEP 3

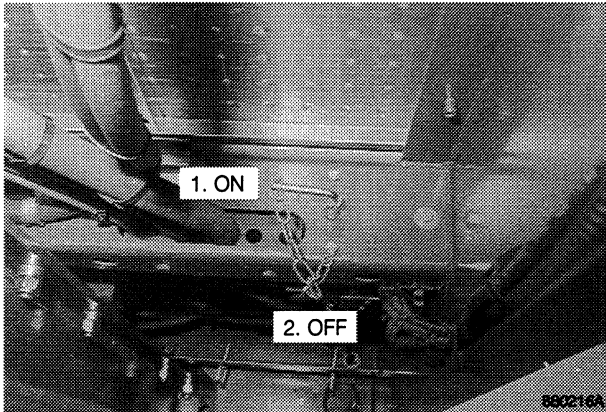

500216A

Turn the master disconnect switch, located under the left hand side of the walkway, to the OFF position and remove the key.

STEP 4

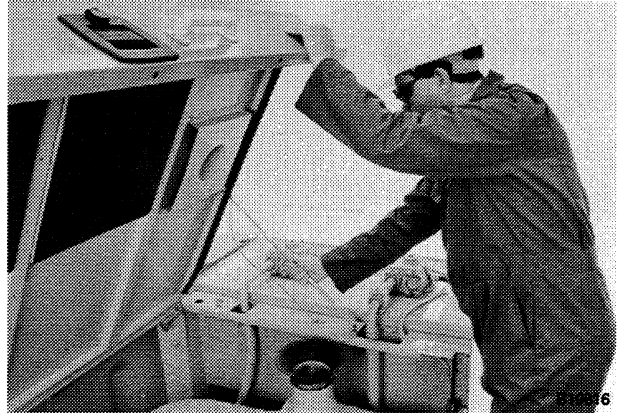

510036

Raise the engine upper cover and install the support rod. Lift and remove the engine front cover.

STEP 5

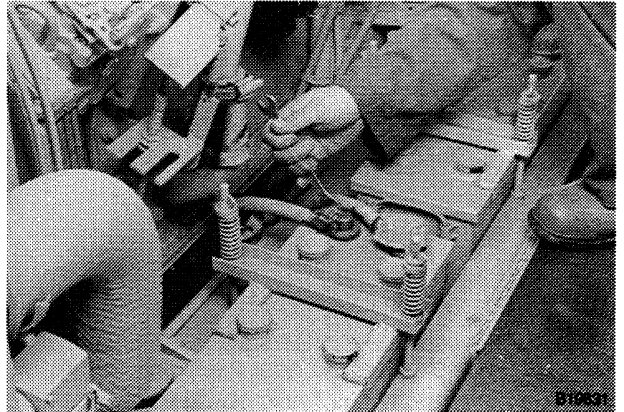

510031

Remove the battery cover. Disconnect the battery negative (-) cable first as shown. Disconnect the remaining cables. Remove the battery clamps and remove the batteries.

STEP 6

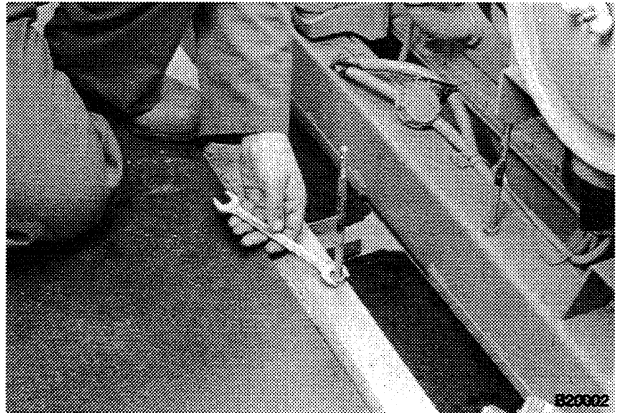

500002

For safety, remove the battery securing bolts and nuts.

STEP 7

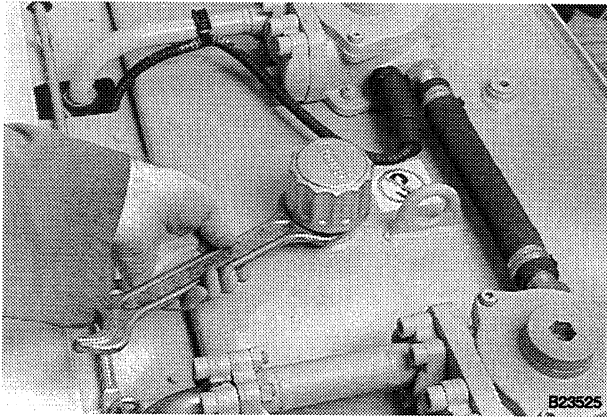

Remove the hydraulic tank breather to release the pressure in the tank. Install and tighten the breather.

STEP 8

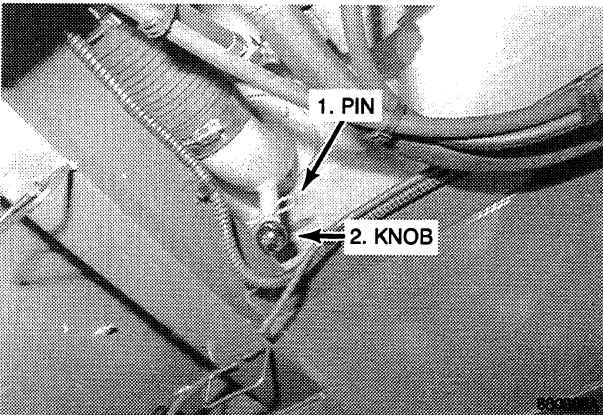

Remove the access panel under the hydraulic oil tank. Remove the pin and pull the knob down to close the hydraulic oil tank shutoff valve.

STEP 9

Remove the access panel under the engine.
Remove the access panel under the radiator.



Hot coolant can spray out if the radiator cap is removed. To remove the radiator cap, let the cooling system cool, turn to the first notch, and wait until the pressure is released. Then, remove the radiator cap.

STEP 10

Remove the radiator cap.

STEP 11

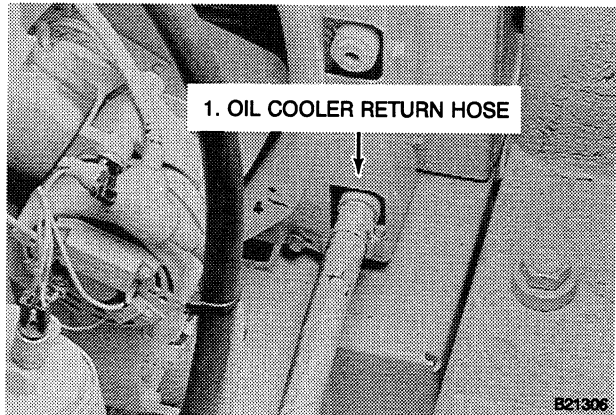
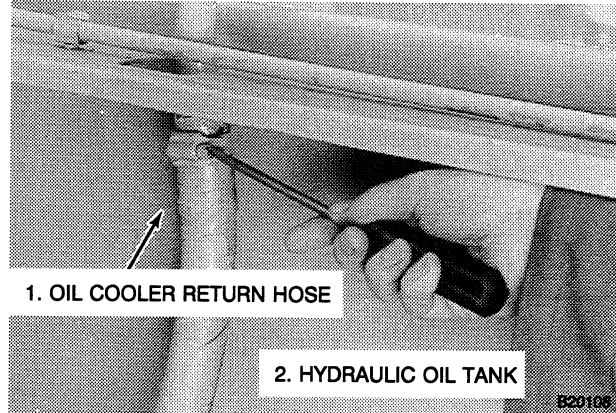

To avoid spillage, disconnect the oil cooler return hose from the hydraulic oil tank and drain the oil from the oil cooler into a clean container. Connect the hose to the tank and then disconnect the hose from the oil cooler.

STEP 12

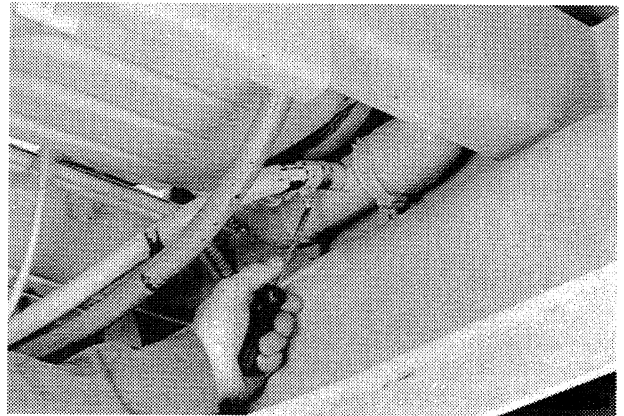

Place a clean container under the radiator, disconnect the heater hose and drain the radiator.

STEP 13

Remove the top and bottom radiator hoses.

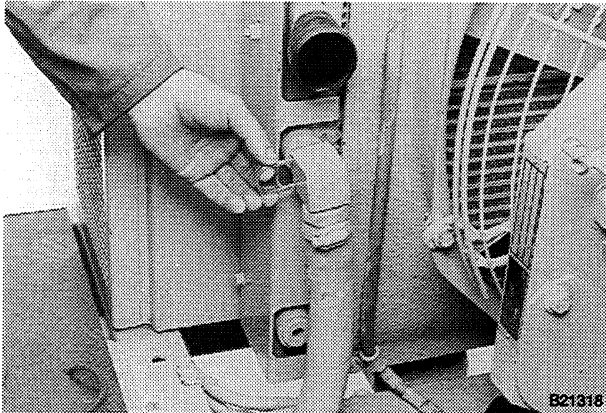
STEP 14

Remove the clip from the oil cooler feed block and disconnect the block from the oil cooler.

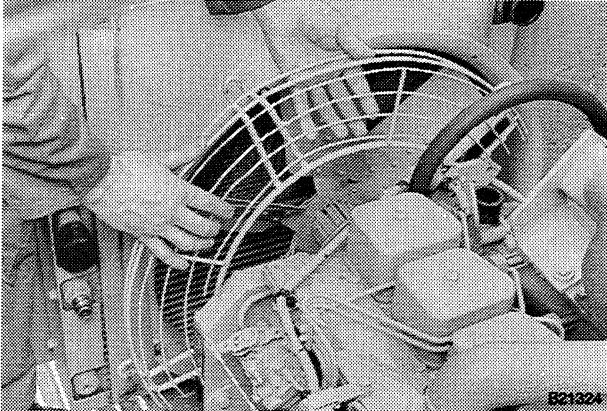
STEP 15

Remove the fan guard mounting bolts, spacers and nuts. Remove the fan guard.

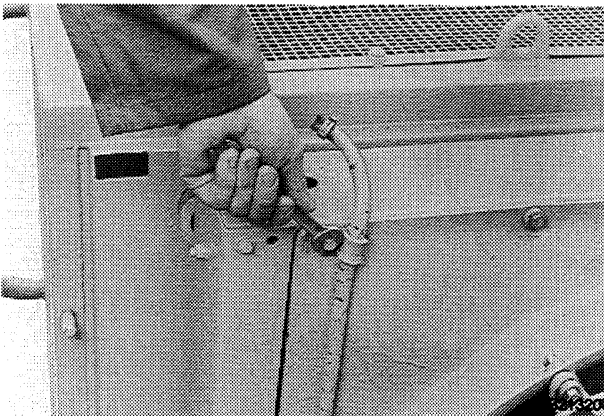
STEP 16

Disconnect the coolant recovery hose and remove the fan shroud mounting bolts and spacers.

STEP 17

Remove the fan mounting bolts and spacers. Remove the fan, fan spacer and shroud.

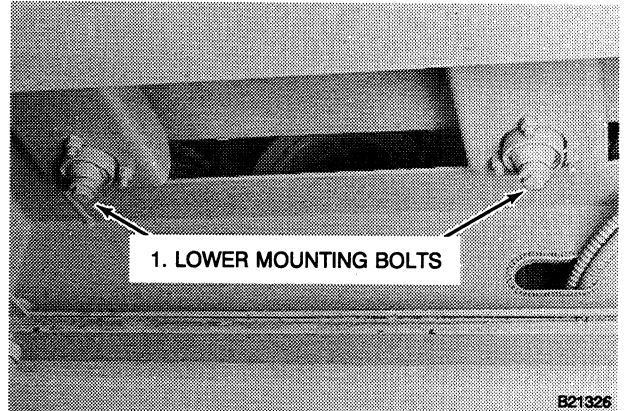
STEP 18

Remove the radiator lower mounting bolts and spacers.

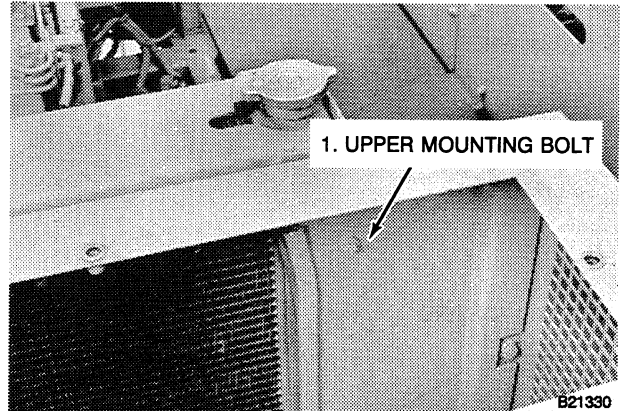
STEP 19

Remove the radiator shroud upper grille mounting bolts and spacers and remove the grille. Remove the radiator upper mounting bolts and spacers.

STEP 20

Remove the radiator.

NOTE: Remove the upper rubber radiator mountings from the radiator. Remove the lower rubber radiator mountings from the radiator shroud. Check the rubber radiator mountings for wear or damage and replace as necessary.



Suggest:

If the above button click is invalid.

Please download this document

first, and then click the above link

to download the complete manual.

Thank you so much for reading

Installation

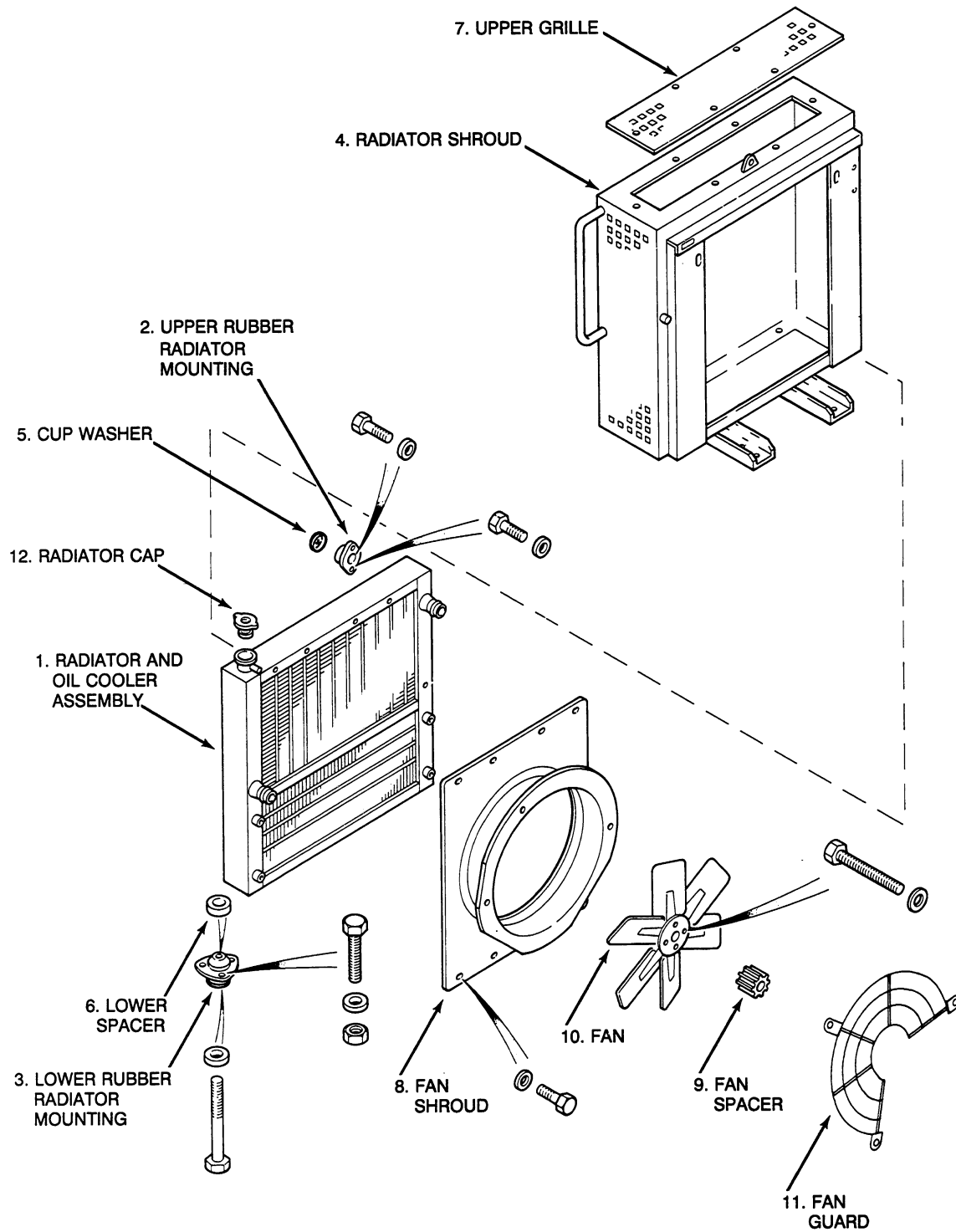

20011A

<https://www.ebooklibonline.com>

Hello dear friend!

Thank you very much for reading.

Enter the link into your browser.

The full manual is available for immediate download.

<https://www.ebooklibonline.com>