

1021F
1121F
Tier 2
Wheel Loader

SERVICE MANUAL

Part number 47392461
1st edition English
July 2012



Contents

INTRODUCTION

Engine.....	10
Engine and crankcase.....	10.001
Air cleaners and lines.....	10.202
Engine lubrication system	10.304
Aftercooler.....	10.310
Fan and drive.....	10.414
Transmission.....	21
Powershift transmission	21.113
Powershift transmission external controls	21.135
Gearbox internal components	21.145
Powershift transmission internal components.....	21.155
Four-Wheel Drive (4WD) system	23
Drive shaft.....	23.314
Front axle system	25
Powered front axle	25.100
Front bevel gear set and differential.....	25.102
Final drive hub, steering knuckles, and shafts	25.108
Rear axle system.....	27
Powered rear axle	27.100
Brakes and controls	33
Parking brake / Parking lock.....	33.110
Hydraulic service brakes	33.202
Hydraulic systems.....	35
Hydraulic systems	35.000
Variable displacement pump	35.106
Reservoir, cooler, and filters.....	35.300

Pilot system.....	35.357
Main control valve	35.359
Auxiliary hydraulic valves and lines	35.525
Front loader arm hydraulic system	35.701
Steering.....	41
Auxiliary steering	41.910
Wheels.....	44
Front wheels.....	44.511
Cab climate control	50
Air conditioning	50.200
Electrical systems	55
Electrical system	55.000
Fuel tank system	55.011
Engine cooling system	55.012
Engine control system.....	55.015
Transmission control system	55.024
Service brake electrical system	55.030
Parking brake electrical system	55.031
Hydraulic system control	55.036
Steering control system	55.047
Heating, Ventilation, and Air-Conditioning (HVAC) control system.....	55.050
Cab Heating, Ventilation, and Air-Conditioning (HVAC) controls.....	55.051
Harnesses and connectors	55.100
Engine starting system	55.201
Cold start aid	55.202
Alternator	55.301
Battery.....	55.302
External lighting	55.404
External lighting switches and relays.....	55.405

<https://www.ebooklibonline.com>

Hello dear friend!

Thank you very much for reading.

Enter the link into your browser.

The full manual is available for immediate download.

<https://www.ebooklibonline.com>

Warning indicators, alarms, and instruments.....	55.408
Loader arm and bucket control system.....	55.415
Cab/Platform harnesses and connectors.....	55.510
Cab controls	55.512
Cab lighting	55.514
Wiper/Washer system	55.518
Cab brake controls	55.519
Cab controls (Lift arm, Boom, Dipper, Bucket)	55.524
FAULT CODES	55.DTC
Platform, cab, bodywork, and decals	90
Machine shields and guards.....	90.105
Protections and footboards.....	90.118
Pneumatically-adjusted operator seat.....	90.124
Cab	90.150



INTRODUCTION

Torque

1021F INT, 1121F INT

Alternator

Alternator pulley retaining nut	95 - 109 N·m (70 - 80 lb ft)
Battery terminal nut	6 - 8 N·m (55 - 72 lb in)
Indicator light terminal nut	2 - 3 N·m (16 - 24 lb in)

Axle

Planetary carrier lock screws	200 N·m (148 lb ft)
Brake spring retainer cover	34 N·m (25 lb ft)
Axle wheel end screw plug	50 N·m (37 lb ft)
Nut Securing Brake Tube to Connector	100 N·m (74 lb ft)
Brake Tube Fitting to Wheel End Fitting	36 N·m (27 lb ft)
Axle housing bolts	560 N·m (413 lb ft)
Input flange slotted nut	1200 N·m (885 lb ft)
Differential releasing housing cover bolts	185 N·m (136 lb ft)
Differential housing cover bolts	400 N·m (295 lb ft)
Wheel mounting bolts	644 - 719 N·m (475 - 530 lb ft)
Axle breather valve	4 - 6 N·m (35 - 53 lb in)
Front axle mounting bolts	1519 - 1708 N·m (1120 - 1260 lb ft)
Rear trunnion cover bolts	103 - 115 N·m (76 - 85 lb ft)
Rear trunnion spacer bolts	285 - 319 N·m (210 - 235 lb ft)
Trunnion casting mounting	651 - 732 N·m (480 - 540 lb ft)

Chassis

Cab and canopy mounting bolts	773 - 854 N·m (570 - 630 lb ft)
Counterweight mounting bolts	1125 - 1261 N·m (830 - 930 lb ft)
Lower step support bolts	27 - 31 N·m (20 - 23 lb ft)
Battery hold down bolts	651 - 732 N·m (480 - 540 lb ft)

Cooling

Cooling frame mounting	271 - 298 N·m (200 - 220 lb ft)
Fan mounting nut	109 - 122 N·m (80 - 90 lb ft)

Drivetrain

Flex plate to flywheel bolts	33 - 41 N·m (24 - 30 lb ft)
Carrier bearing bolt	149 - 163 N·m (110 - 120 lb ft)
Drive line mounting bolts	136 - 149 N·m (100 - 110 lb ft)
Transmission sight gauge mounting bolts	3 - 5 N·m (24 - 48 lb in)
Transmission shock mount nuts	929 - 1044 N·m (685 - 770 lb ft)
Transmission-to-bracket bolts	1125 - 1275 N·m (830 - 940 lb ft)
Transmission-to-flywheel housing bolts	54 - 60 N·m (40 - 44 lb ft)
Transmission fill tube bolts	17 - 33 N·m (151 - 292 lb in)
Banjo tube bolt	160 N·m (118 lb ft)
Bypass valve hose clamps	10 - 11 N·m (90 - 100 lb in)

Engine

Air intake hose clamps	4 - 5 N·m (35 - 44 lb in)
Aspirator hose clamps	3 N·m (30 lb in)
Muffler flex tube clamp	18 - 22 N·m (13 - 16 lb ft)
Muffler clamp at turbo	5 - 6 N·m (44 - 53 lb in)
Starter motor mounting bolts	41 - 48 N·m (30 - 35 lb ft)
Engine support bracket-to-rear chassis bolts	386 - 434 N·m (285 - 320 lb ft)
Engine shock mount nuts	397 - 447 N·m (293 - 330 lb ft)

Fuel tank

Tighten the fuel sender bolts in the sequence as shown in the image (2) to a torque of **6 - 8 N·m (53 - 71 lb in)**.

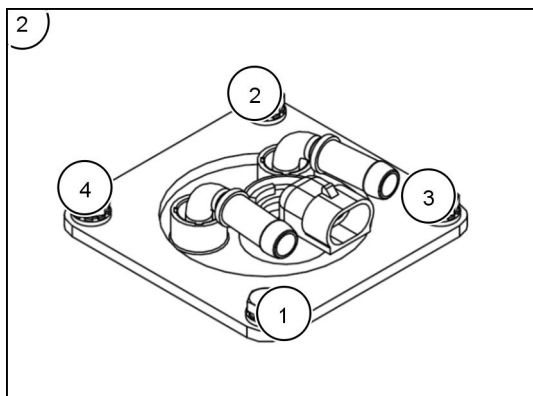

RCPH11WHL117AAR 1

Fuel sender mounting bolts	6 - 8 N·m (53 - 71 lb in)
Fuel tank skid plate bolts (bolts and nuts are to be torqued only one time. Replace as necessary)	122 - 164 N·m (90 - 121 lb ft)
Fuel tank mounting bolts (bolts and nuts are to be torqued only one time. Replace as necessary)	301 - 407 N·m (222 - 300 lb ft)

Hydraulics

Priority valve mounting bolts	85 - 102 N·m (63 - 75 lb ft)
Main hydraulic pump elbow	85 - 102 N·m (63 - 75 lb ft)
Hydraulic tank sight gauge mounting	3 - 6 N·m (27 - 53 lb in)
Surge tank hose clamp mounting	48 N·m (35 lb ft)
Brake pump mounting bolts	149 - 170 N·m (110 - 125 lb ft)
Hydraulic oil tank suction hose clamps	10 - 11 N·m (90 - 100 lb in)
Split, half clamp flange bolts (hydraulic tank-to-pumps and priority valve-to-pump)	73 - 90 N·m (54 - 67 lb ft)
Split, half clamp flange bolts (priority valve-to-loader valve)	198 - 242 N·m (146 - 179 lb ft)
Pump mounting bolts	149 - 170 N·m (110 - 125 lb ft)

CASE

CONSTRUCTION

SERVICE MANUAL

Engine

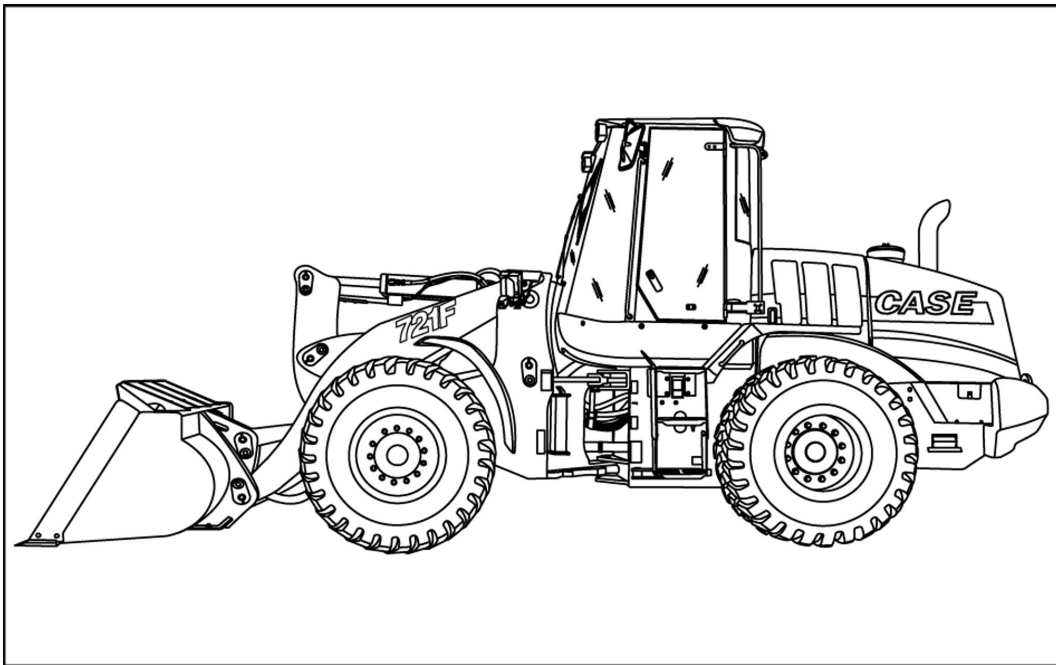

1021F
1121F

Engine - Remove

1021F INT, 1121F INT

Prior operation:

Engine hood - Remove (90.105)

NOTE: Put caps on the fittings and plugs in the hoses to prevent foreign material from entering the system when disconnecting fuel lines or hydraulic hoses.

1. Park the machine on a level surface and lower the bucket to the ground. Put the articulation lock **(1)** in the locked position.

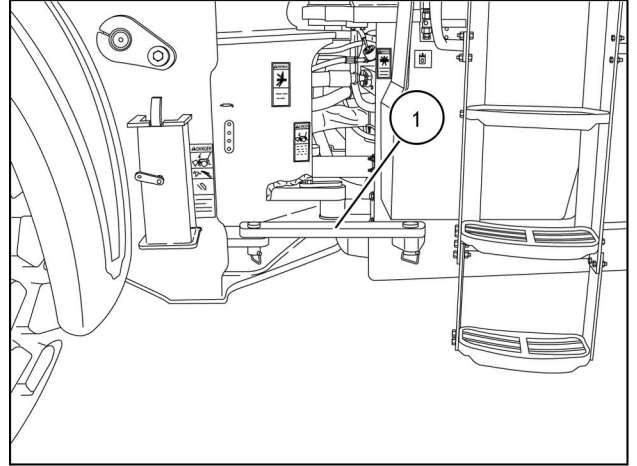

RCPH11WHL039AAH 1

2. Key in the run position, engine off, place the pilot control switch **(1)** in the normal operation position.

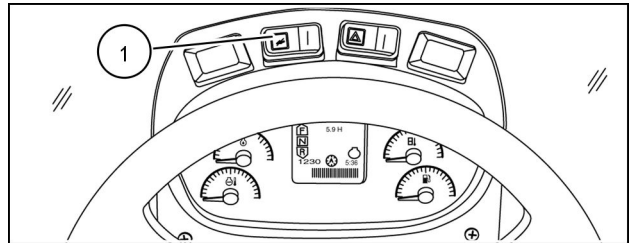

RCPH10WHL982FAH 2

3. Move the loader hydraulic control handle to the raise and lower position in order to release any hydraulic pressure in the lift circuit.
4. Move the loader control handle in and out of the tilt position several times, this will relieve any pressure in the pilot accumulator.
5. Release the pressure in the ride control accumulator with the bleeder valve in the valve load travel stabilizer.
6. Depress the brake pedal several times to discharge brake accumulators.
7. Slowly loosen the filler cap on the hydraulic oil tank to release air pressure.

8. Put the master disconnect switch **(1)** in the off position.

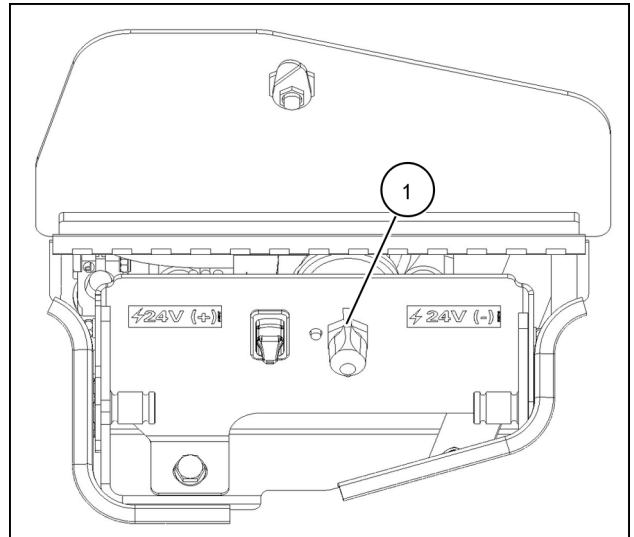

RCPH11WHL094AAH 3

9. Drain the engine radiator coolant.
10. Drain the engine oil.
11. Loosen the hose clamp **(1)** on the air intake hose under the air inlet hood.

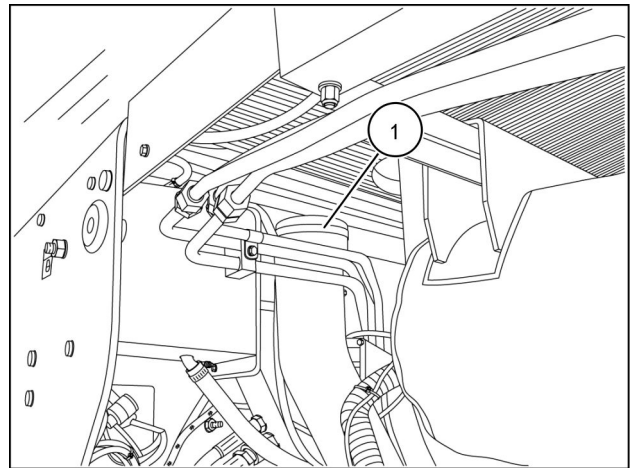

RCPH11WHL053AAR 4

12. Remove the mounting bolts on the exhaust stack hood. Attach lifting equipment to the exhaust stack. Remove the exhaust stack hood **(1)**.

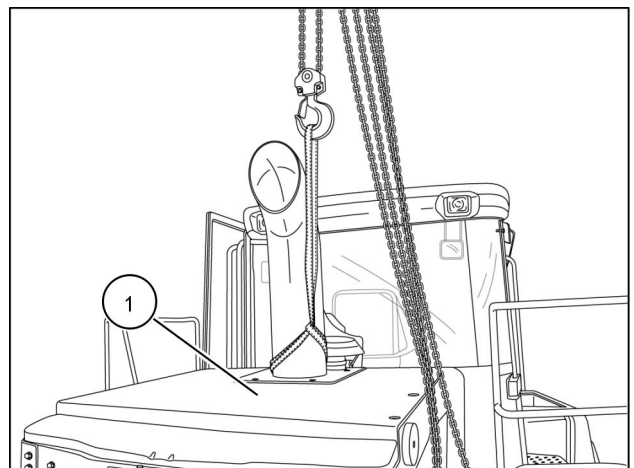

RCPH11WHL010AAR 5

13. Remove the muffler assembly.

14. Disconnect the deaeration tank overflow hose (2).
15. Remove the P-clamps (1) that secure the overflow hose to the wall and brackets. Position the overflow hose away from the engine and engine wall.

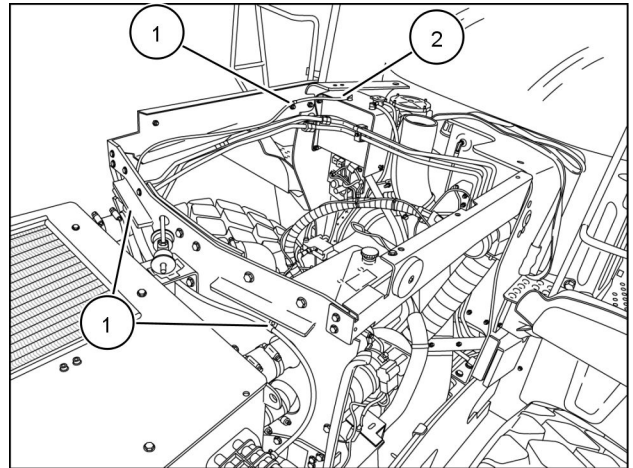

RCPH11WHL012AAR 6

16. Remove the left bracket (1) and right bracket (2).

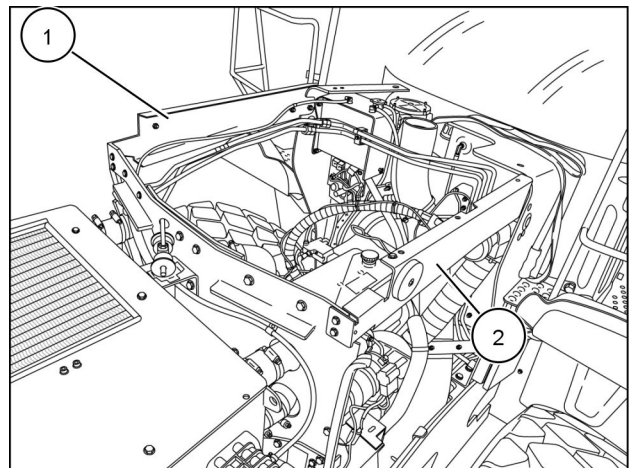

RCPH11WHL012AAR 7

17. Remove the hydraulic oil lines (1).

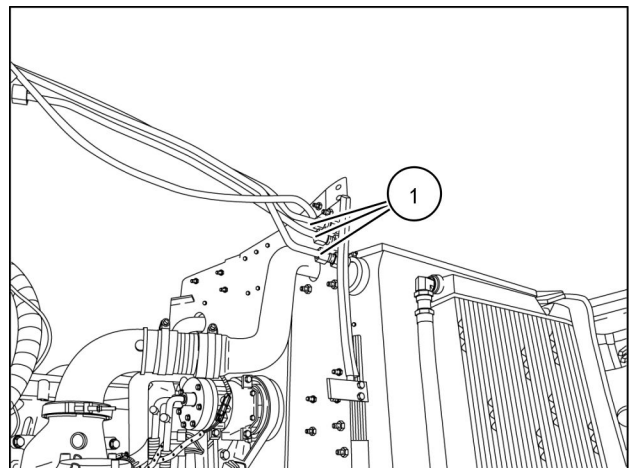

RCPH11WHL013AAR 8

18. Remove the after air cooler tube (1) .
19. Remove the bulkheads (2).

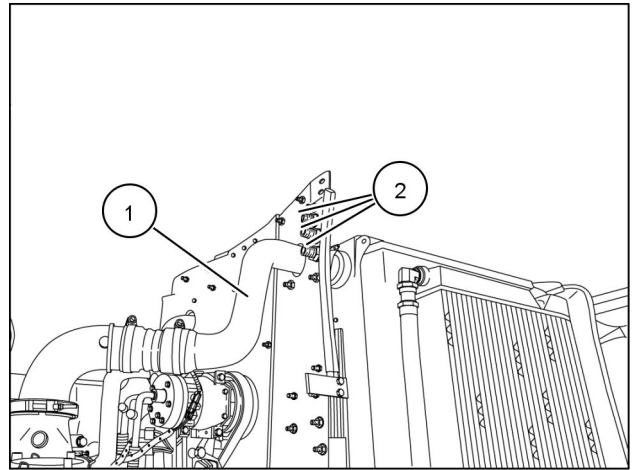

RCPH11WHL014AAR 9

20. Remove the oil dipstick P-clamp (3) . Pull the oil dipstick tube (1) through the wall.
21. Label and disconnect the hood lift strut electrical connector (2).

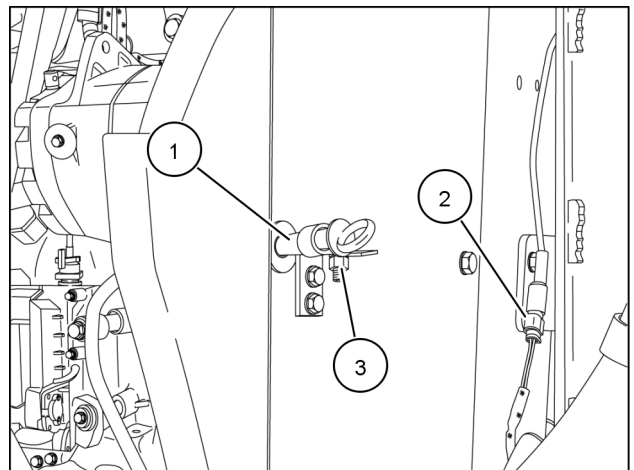

RCPH11WHL015AAR 10

22. Remove the before air cooler tube (1).
23. Remove the upper radiator tube (2).

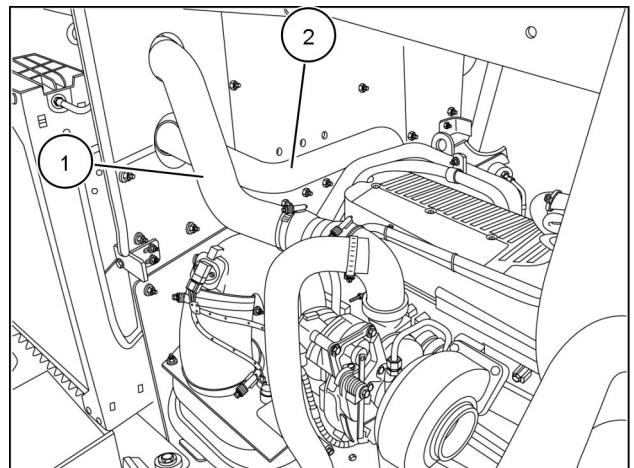

RCPH11WHL016AAR 11

24. Label and disconnect the humidity sensor electrical connector **(1)**.
25. Remove the turbo inlet tube **(2)**.
26. Label and disconnect the air filter restriction sensor electrical connector **(3)**.

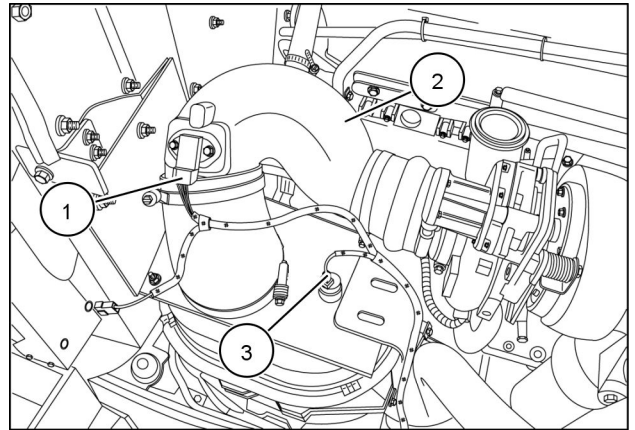

RCPH11WHL017AAR 12

27. Remove the wire harness P-clamp **(1)**.
28. Loosen the hose clamp on the air intake hose **(2)**. Disconnect the air intake hose **(3)**.

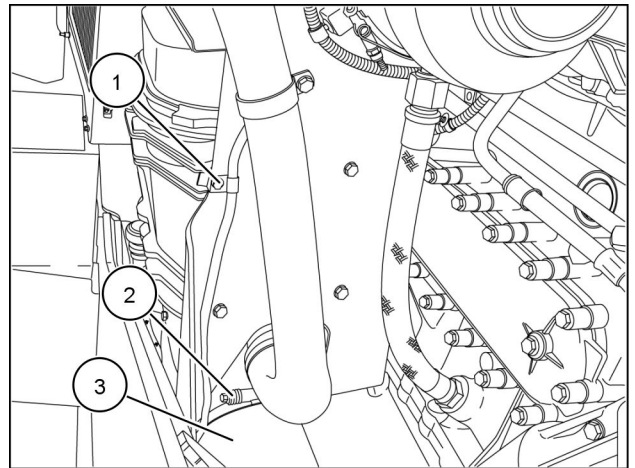

RCPH11WHL018AAR 13

29. Remove the lower, right panel **(1)** on the engine wall.

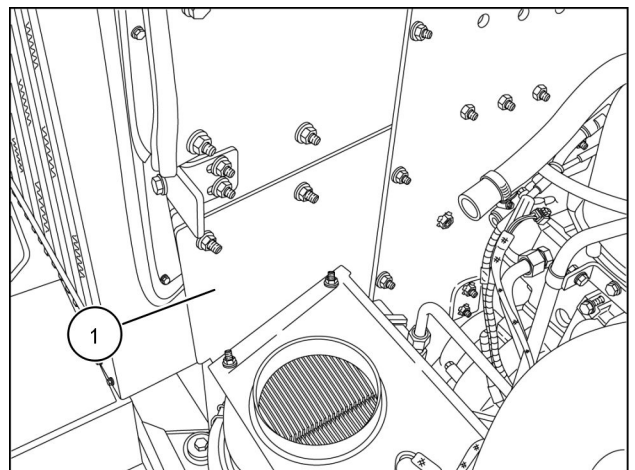

RCPH11WHL020AAR 14

30. Remove the air box assembly.

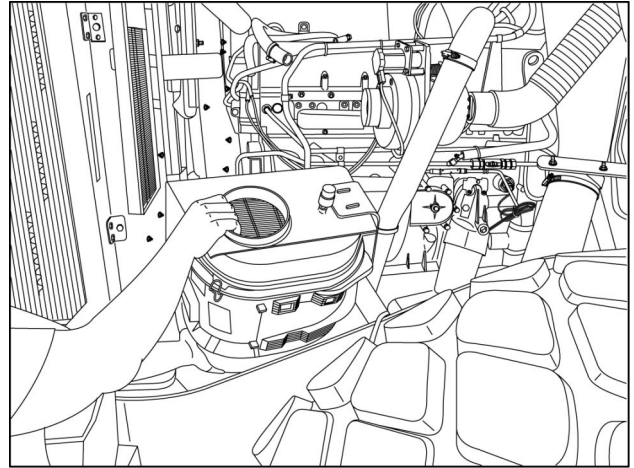

RCPH11WHL019AAR 15

31. Remove the lower radiator tube (1) .

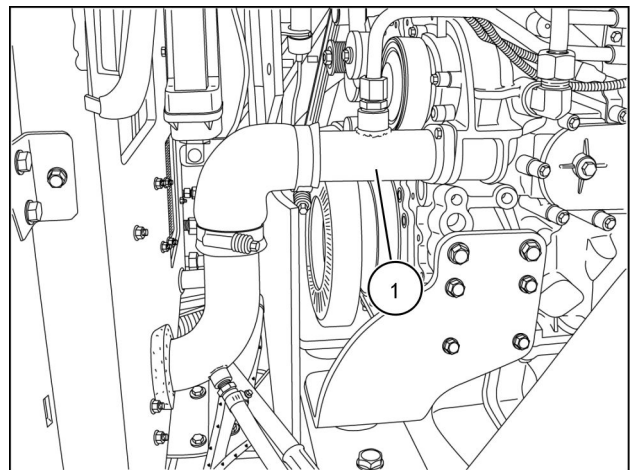

RCPH11WHL021AAR 16

32. Attach lifting equipment to the engine wall. Remove the engine wall's hold-down bolts. Lift and remove the engine wall.

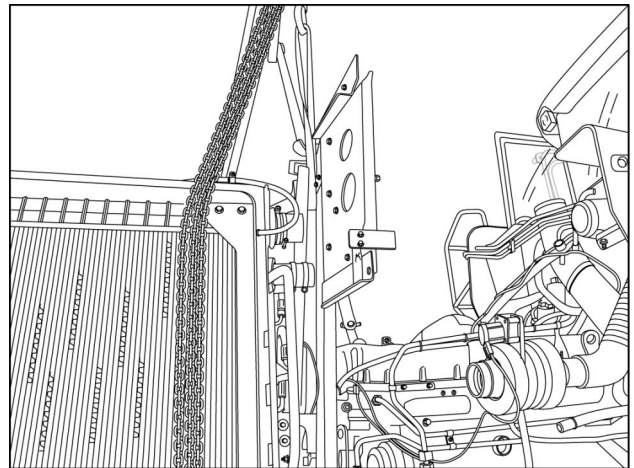

RCPH11WHL039AAR 17

33. Remove the turbo exhaust tube (1).

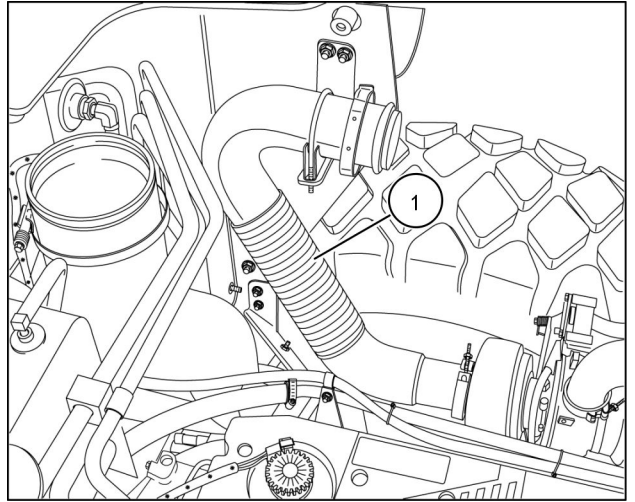

RCPH11WHL022AAR 18

34. Remove two bolts (2), washers (3), and nuts (4). Remove the air intake hose (1).

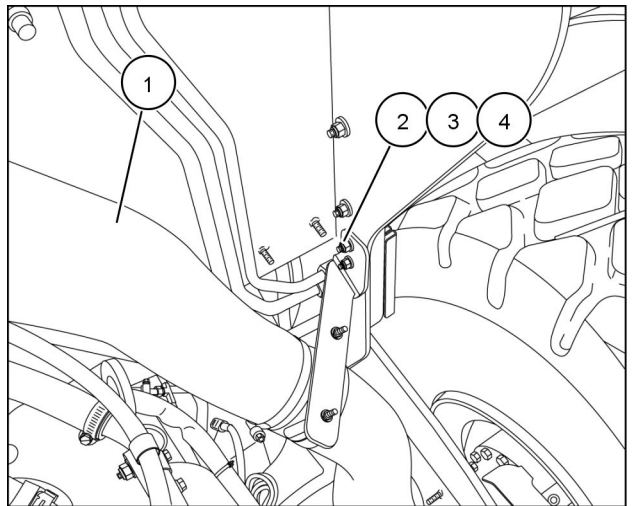

RCPH11WHL023AAR 19

35. Disconnect the inlet and outlet heater core heater hoses (1).

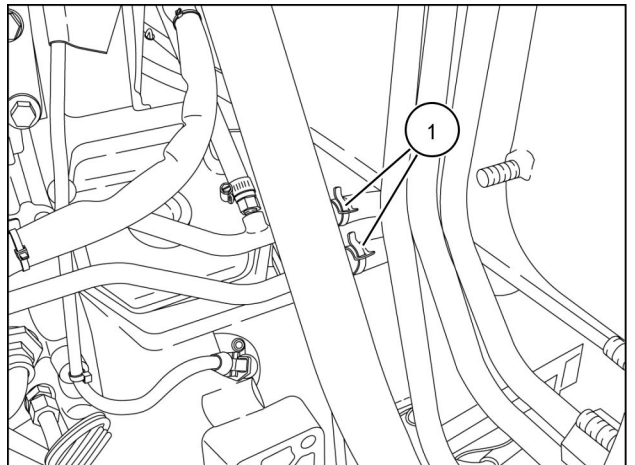

RCPH11WHL038AAR 20

36. Disconnect the starter battery cables **(1)** and starter switch wire **(2)**.

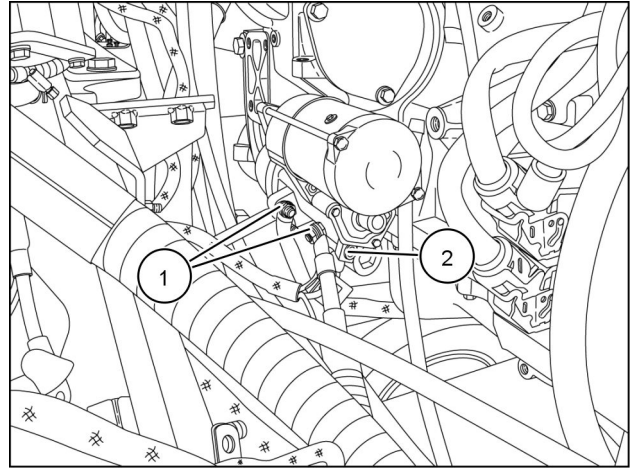

RCPH11WHL049AAR 21

37. Disconnect the following from the crank case ventilation/fuel filter bracket assembly:

- Fuel pump electrical connector
- Water sensor electrical connector
- Ground wire
- Wire harness P-clamp
- Crank case filter inlet hose
- Crank case filter outlet hose
- Crank case filter oil return hose
- Fuel pump inlet tube
- Fuel pump outlet tube

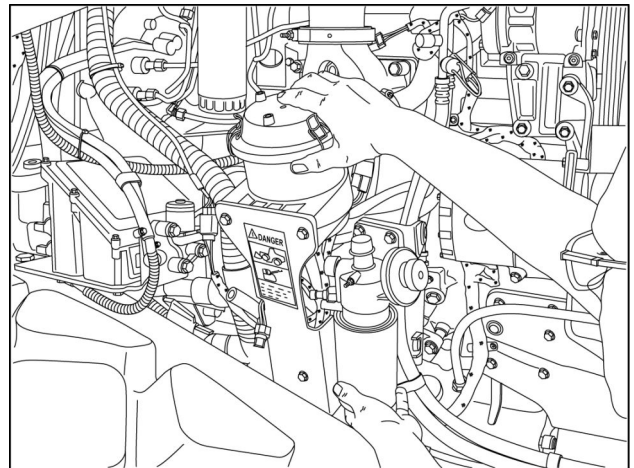

RCPH11WHL040AAR 22

38. Remove the crank case ventilation/fuel filter bracket assembly.

39. Label and disconnect the engine control module electrical connector **(1)**.

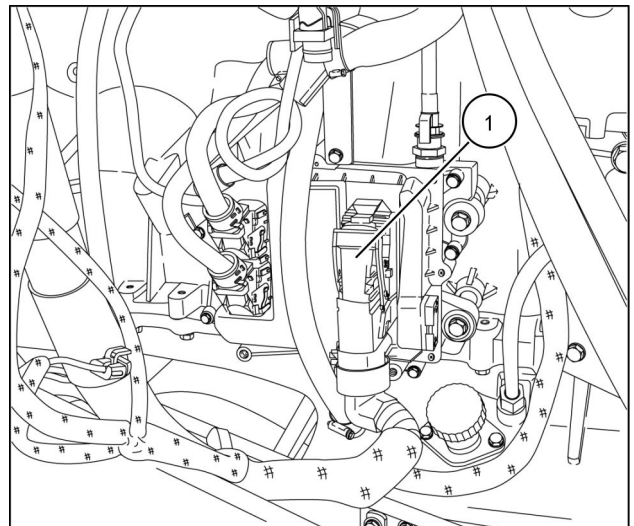

RCPH11WHL041AAR 23

40. Disconnect the fuel return line **(1)**.
41. Disconnect the battery positive wire **(2)** on the air grid heater.

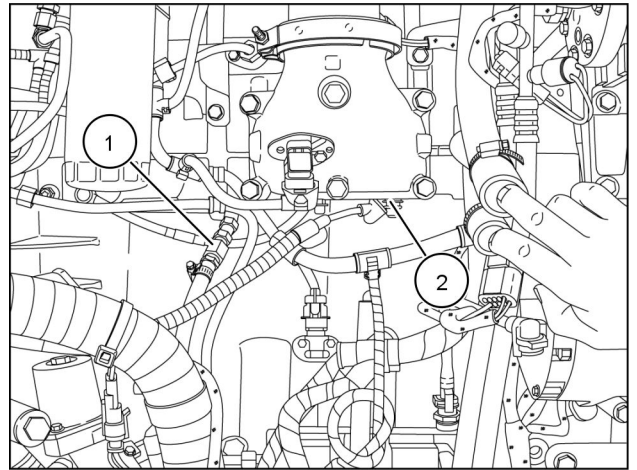

RCPH11WHL042AAR 24

42. Disconnect the engine ground wires **(1)**.
43. Remove the wire harness P-clamp **(2)**.

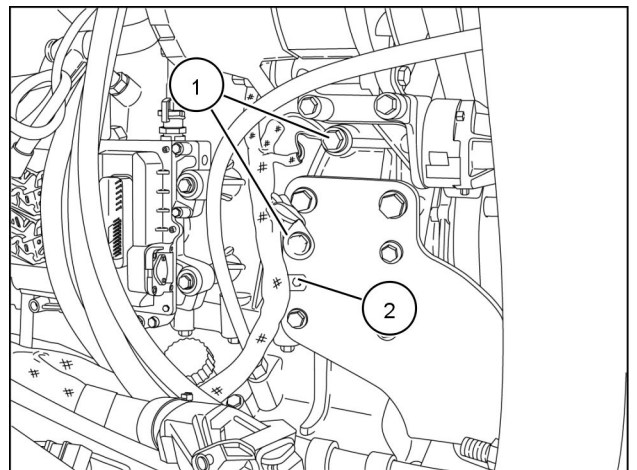

RCPH11WHL043AAR 25

44. Remove the engine serpentine belt **(1)**.

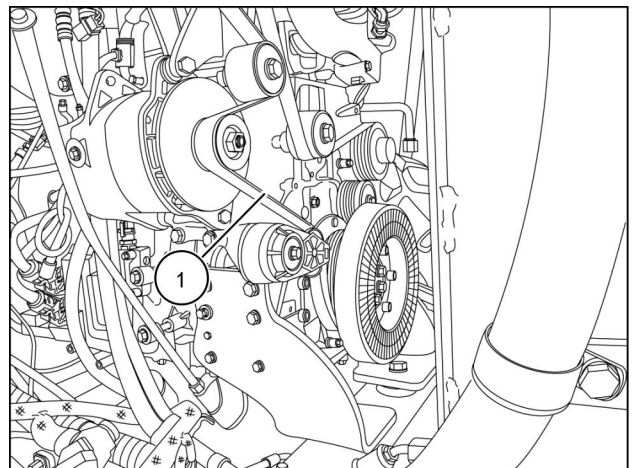

RCPH11WHL051AAR 26

45. Label and disconnect the A/C compressor electrical connector **(1)**.
46. Label and disconnect the A/C pressure switch electrical connector **(4)**.
47. Remove the alternator power wire. **(3)**.
48. Label and disconnect the bulk electrical connector **(5)**.

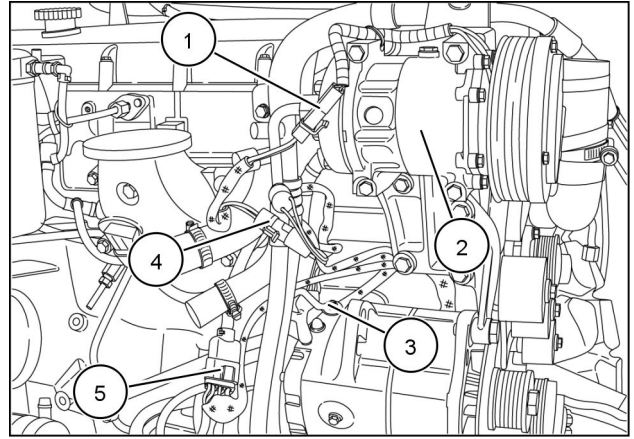

RCPH11WHL045AAR 27

49. Remove the A/C compressor **(2)**. Position the A/C compressor **(2)** away from the engine.
50. Remove the wire harness P-clamps **(1)**.

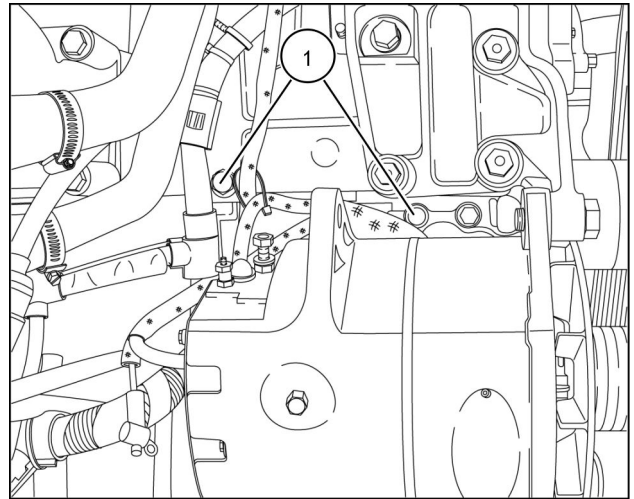

RCPH11WHL046AAR 28

51. Remove the engine oil drain tube **(1)**.

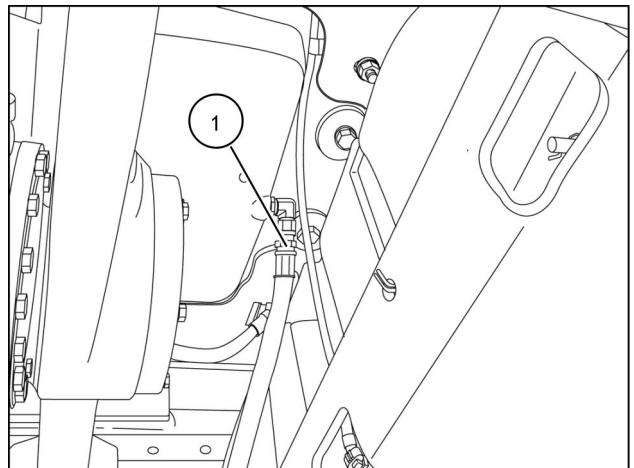

RCPH11WHL047AAR 29

52. Attach lifting equipment to the engine. Support the engine.

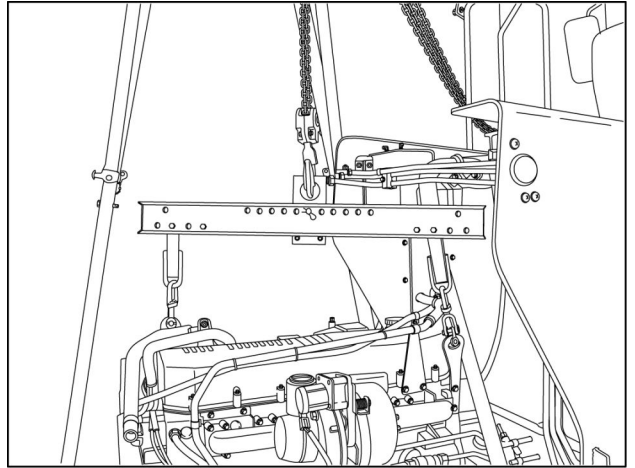

RCPH11WHL048AAR 30

53. Remove the hydraulic oil return tube P-clamp (1). Position the hydraulic oil return tube away from the converter housing cover plate.

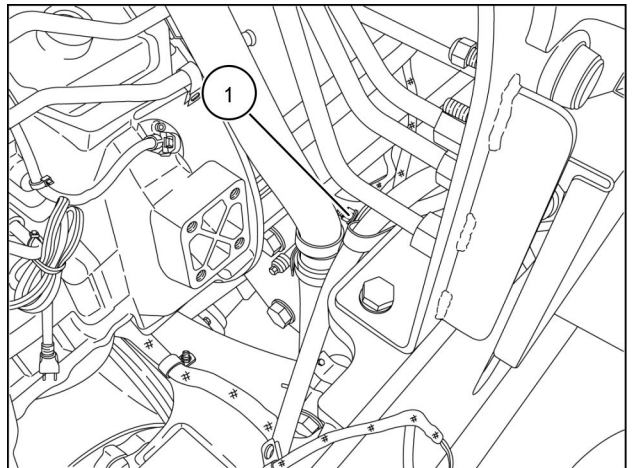

RCPH11WHL050AAR 31

54. For 1021F models, do procedure A. For 1121F models, do procedure B.
- A. Remove the converter housing cover plate (1). See figure 32.
 - B. Remove access cover located above starter, then remove plug behind cover. Carefully remove torque converter bolts through plug hole. Use care to ensure bolts do not fall into engine housing. Supporting figure is currently not available.

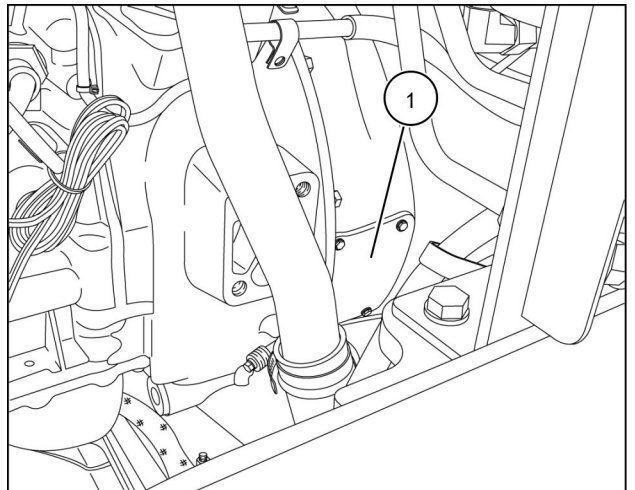

RCPH11WHL034AAR 32

55. Remove the flex plate bolts (1).

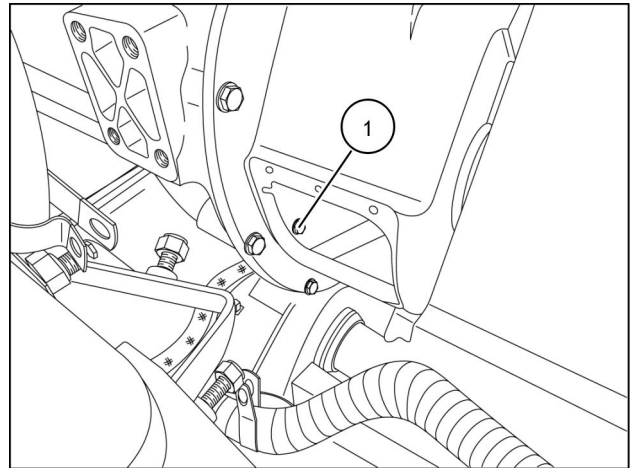

RCPH11WHL035AAR 33

56. Remove the harmonic balancer (1).

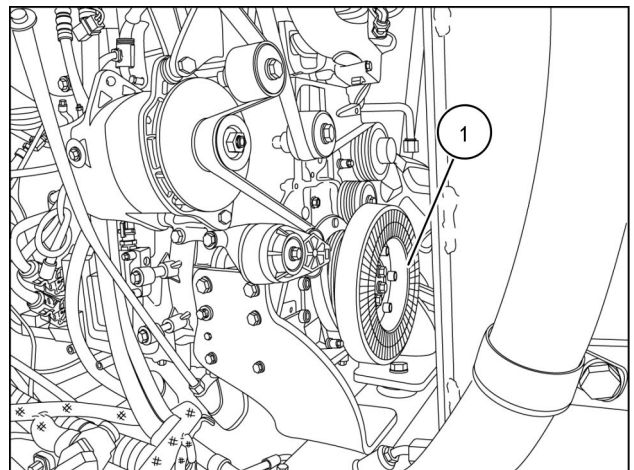

RCPH11WHL051AAR 34

57. Remove the front engine mounts (1) and engine mount plate (2).

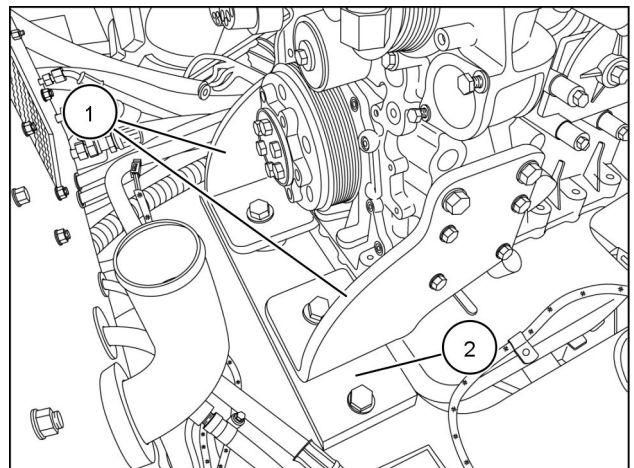

RCPH11WHL052AAR 35

58. Remove the bell housing bolts (1).

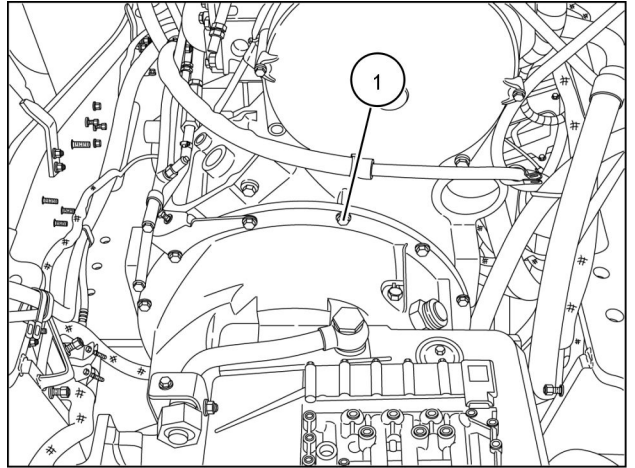

RCPH11WHL036AAR 36

59. Remove the engine.

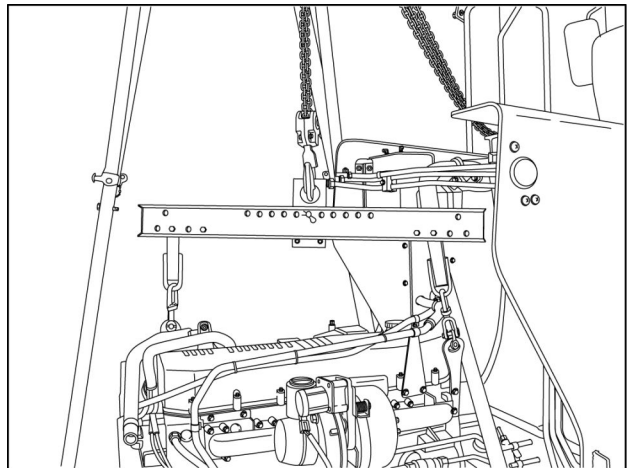

RCPH11WHL048AAR 37

Engine - Install

1021F INT, 1121F INT

1. Carefully lower the engine into the chassis.

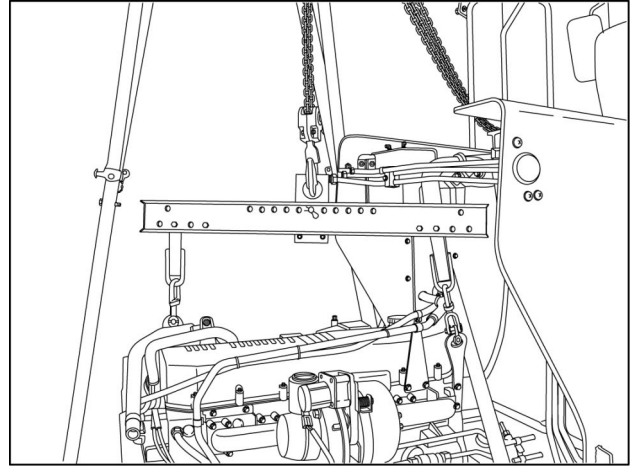

RCPH11WHL048AAR 1

2. Install the bell housing bolts (1). Tighten the bell housing bolts (1) to a torque of **54 - 60 N·m (40 - 44 lb ft)**.

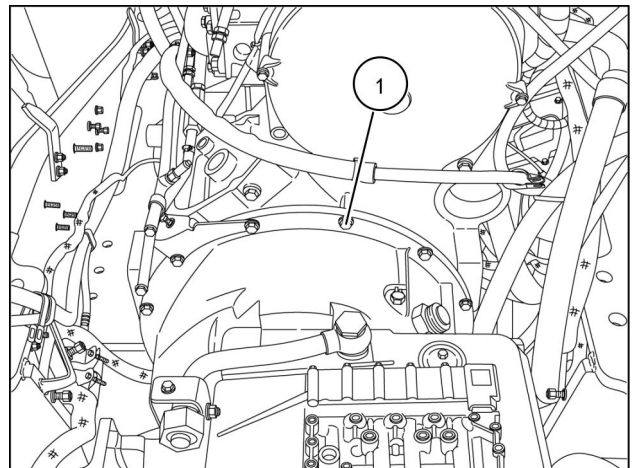

RCPH11WHL036AAR 2

3. Install the engine mount plate (5) and the engine mount brackets (1), but do not tighten the bolts to a torque value.
4. Tighten the engine bracket upper bolts (2) to a torque of **171 - 231 N·m (126 - 170 lb ft)**. Tighten the engine bracket lower bolts (3) to a torque of **69 - 80 N·m (51 - 59 lb ft)**. Tighten the engine mount plate bolts (4) to a torque of **386 - 434 N·m (285 - 320 lb ft)**. Tighten the engine bracket-to-engine mount plate bolts (6) to a torque of **397 - 447 N·m (293 - 330 lb ft)**.

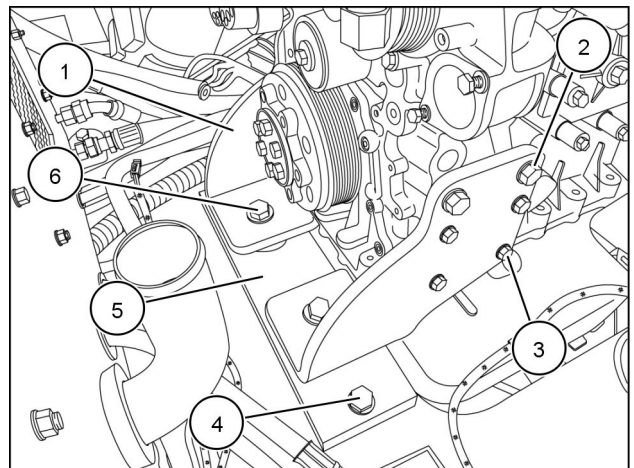

RCPH11WHL052AAR 3

5. Install the harmonic balancer (1). Tighten the harmonic balancer bolts (2) to a torque of **115 N·m (85 lb ft)**.

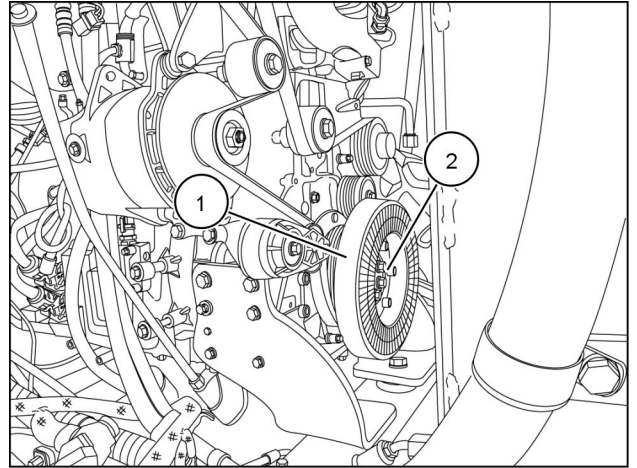

RCPH11WHL051AAR 4

6. Install the flex plate bolts (1). Tighten the flex plate bolts (1) to a torque of **33 - 41 N·m (24 - 30 lb ft)**.

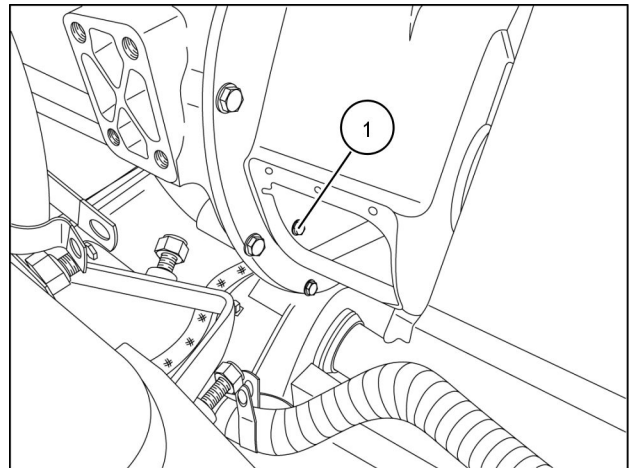

RCPH11WHL035AAR 5

7. For 1021F models, do procedure A. For 1121F models, do procedure B.
- A. Apply **DOW 732 RTV SILICONE CLEAR** to the converter housing cover plate (1). See figure 6.
 - B. Carefully install torque converter bolts through plug hole. Tighten bolts to standard torque. Install plug and housing cover plate. Supporting figure is currently not available.

8. Install the converter housing cover plate (1).

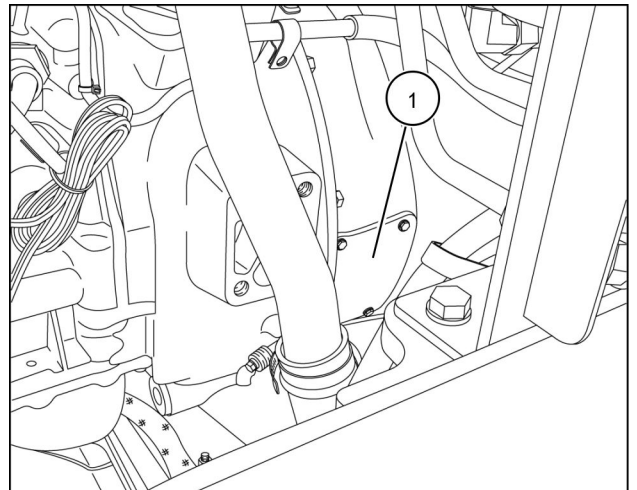

RCPH11WHL034AAR 6

9. Connect the inlet and outlet heater core heater hoses (1).

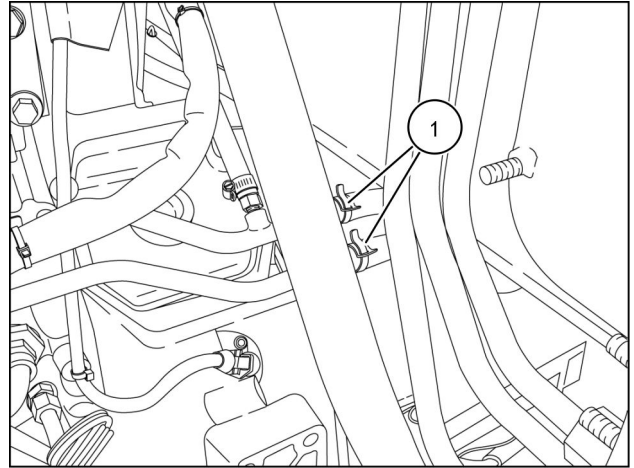

RCPH11WHL038AAR 7

10. Reposition the hydraulic oil return tube. Install the hydraulic oil return tube P-clamp (1).

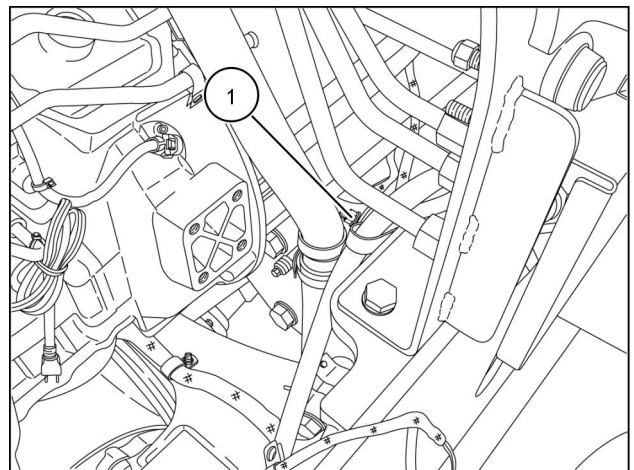

RCPH11WHL050AAR 8

11. Install the air box snorkel (1). Install two bolts (2), washers (3), and nuts (4).

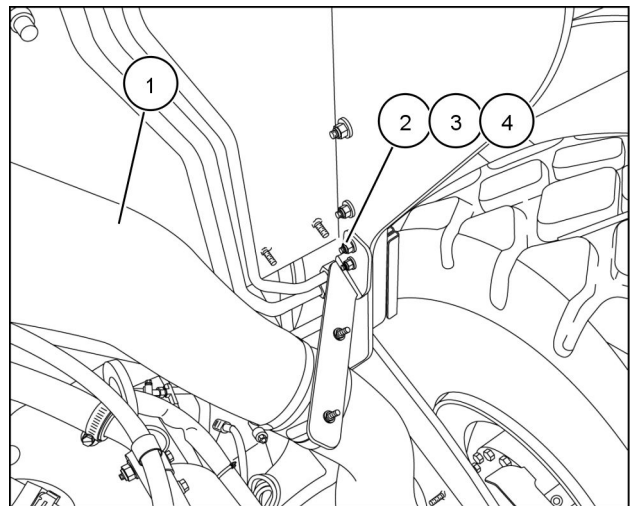

RCPH11WHL023AAR 9

12. Install the turbo exhaust tube (1).
13. Tighten the turbo muffler clamp (2) to a torque of **5 - 6 N·m (44 - 53 lb in)**.

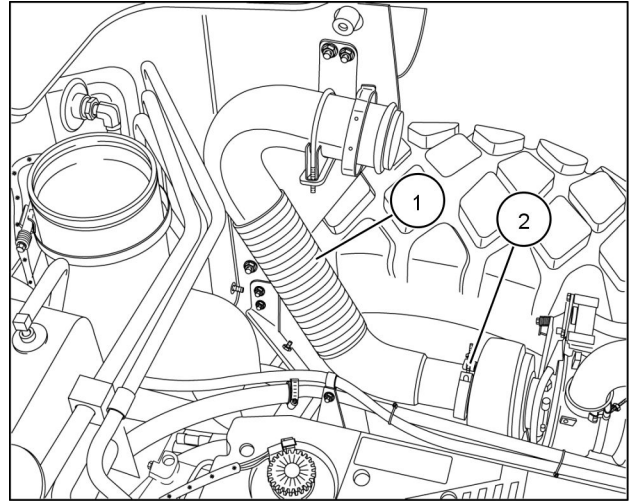

RCPH11WHL022AAR 10

14. Remove lifting equipment (1) from the engine.

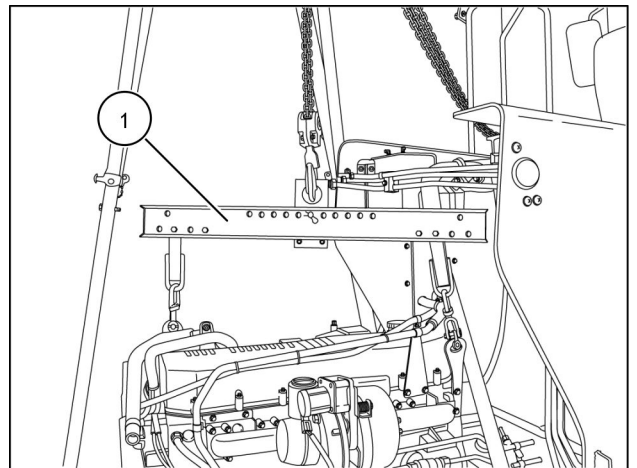

RCPH11WHL048AAR 11

15. Install the engine wall.

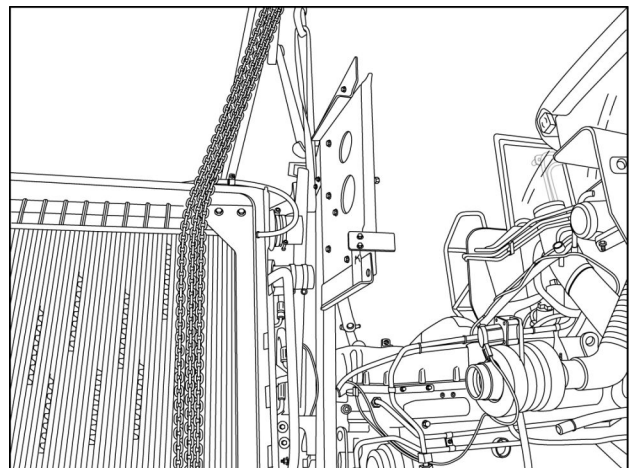

RCPH11WHL039AAR 12

16. Install the lower radiator tube (1).

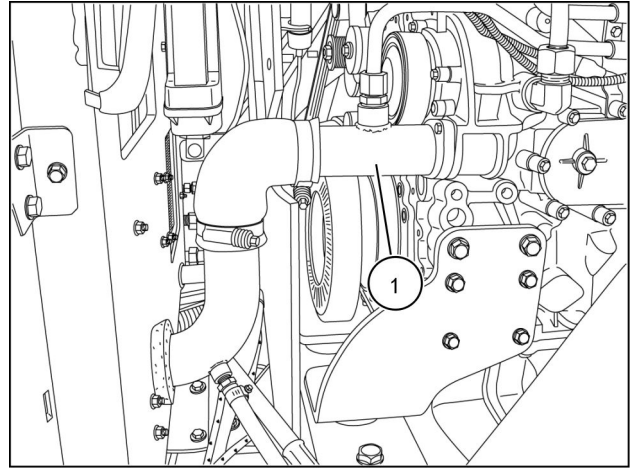

RCPH11WHL021AAR 13

17. Install the air box.

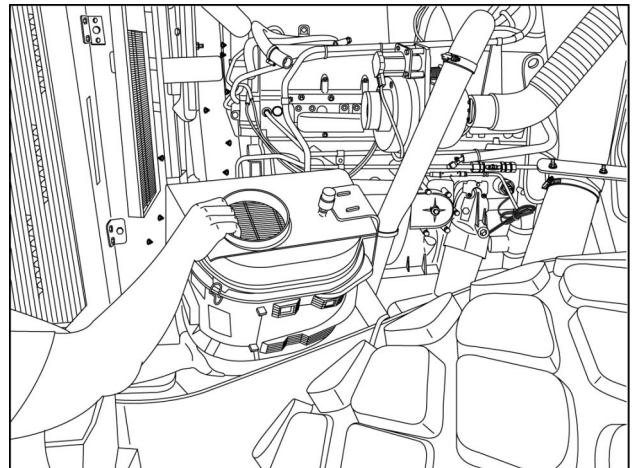

RCPH11WHL019AAR 14

18. Install the wire harness P-clamp (1) .
19. Connect the air intake hose (3). Tighten the hose clamp on the air intake hose (2) to a torque of **4 - 5 N·m (35 - 40 lb in)**.

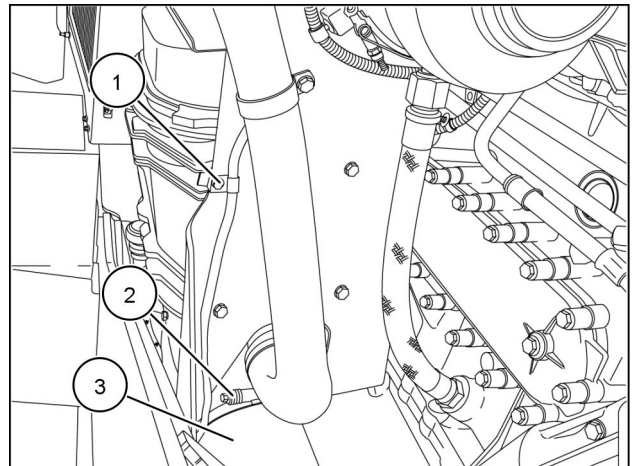

RCPH11WHL018AAR 15

20. Install the lower, right panel (1) on the engine wall.

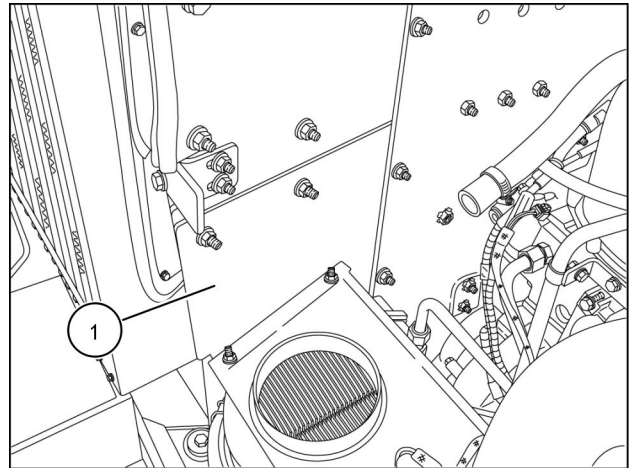

RCPH11WHL020AAR 16

21. Install the turbo inlet tube (2).
22. Tighten the air intake hose clamp (3) to a torque of **4 - 5 N·m (35 - 40 lb in)**.
23. Connect the humidity sensor electrical connector (1).
24. Connect the air filter restriction sensor electrical connector (4).

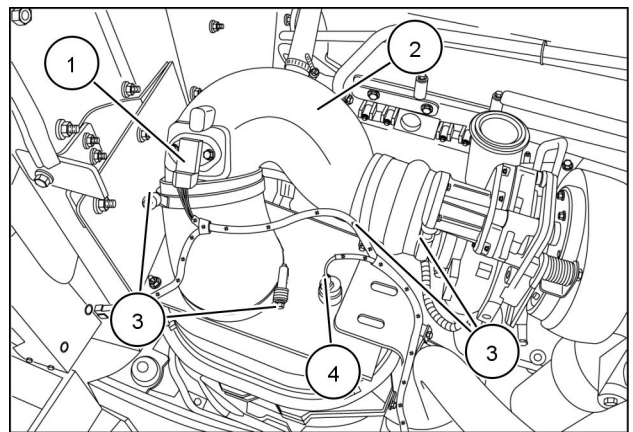

RCPH11WHL017AAR 17

25. Install the upper radiator tube (2).
26. Install the before air cooler tube (1).

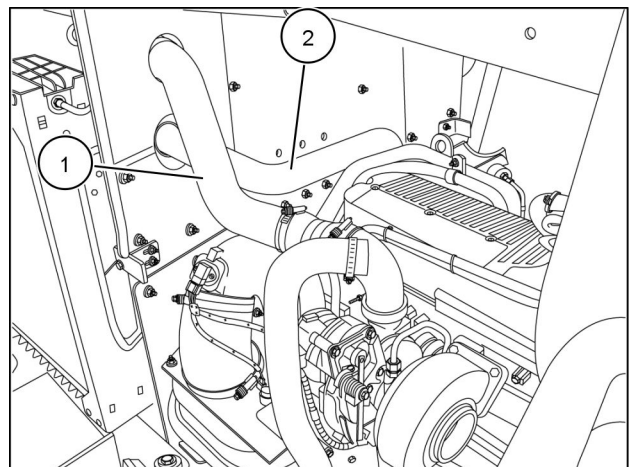

RCPH11WHL016AAR 18

27. Install the engine oil drain tube (1).

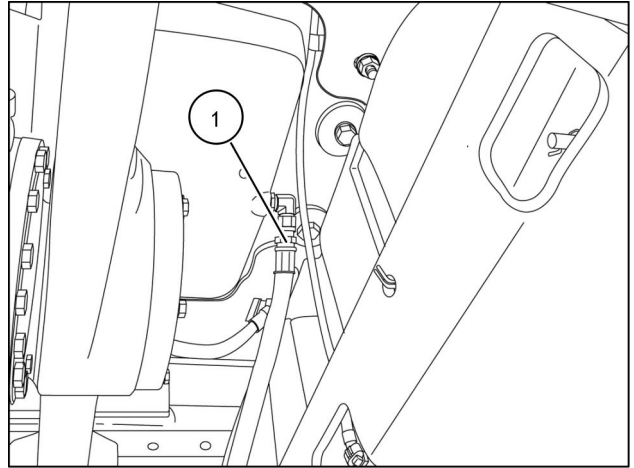

RCPH11WHL047AAR 19

28. Install the wire harness P-clamps (1).

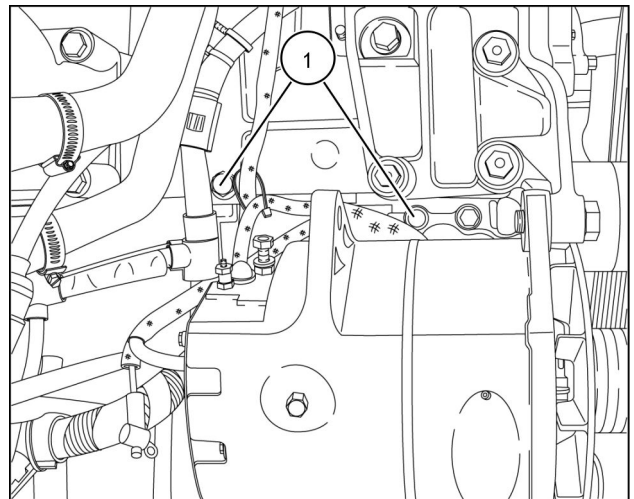

RCPH11WHL046AAR 20

29. Install the engine serpentine belt (1).

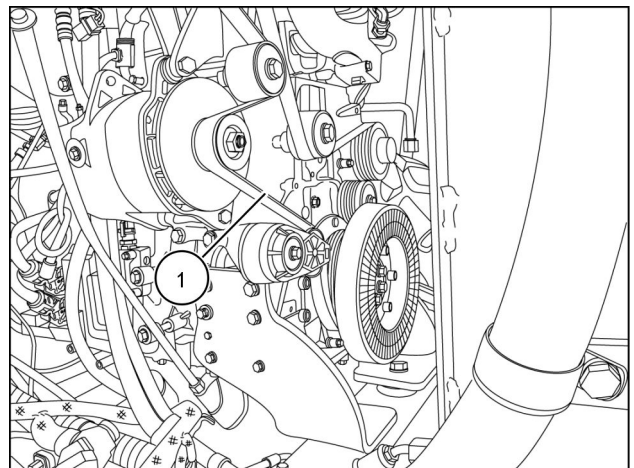

RCPH11WHL051AAR 21

30. Install the A/C compressor (2).
31. Connect the A/C compressor electrical connector (1).
32. Connect the A/C pressure switch electrical connector (4).
33. Connect the alternator power wire (3). Tighten the nut to a torque of **6 - 8 N·m (55 - 70 lb in)**.
34. Connect the bulk electrical connector (5).

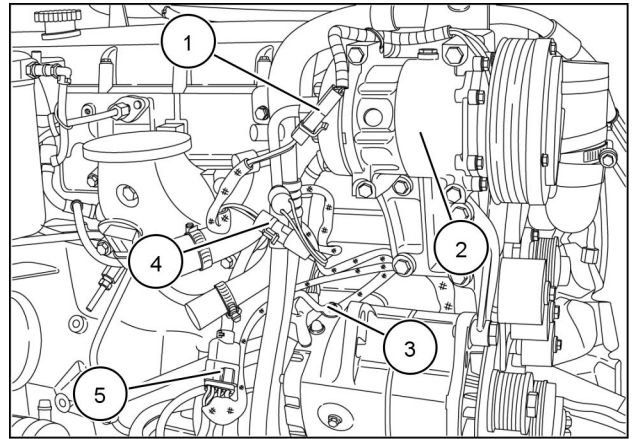

RCPH11WHL045AAR 22

35. Connect the engine ground wires (1).
36. Install the wire harness P-clamp (2).

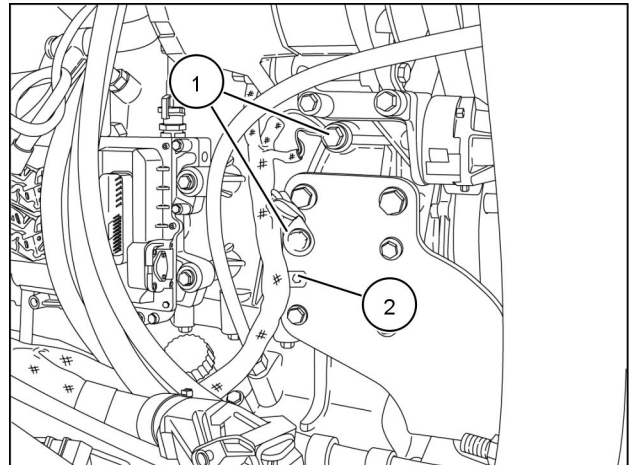

RCPH11WHL043AAR 23

37. Connect the fuel return line (1).
38. Connect the battery positive wire (2) on the air grid heater.

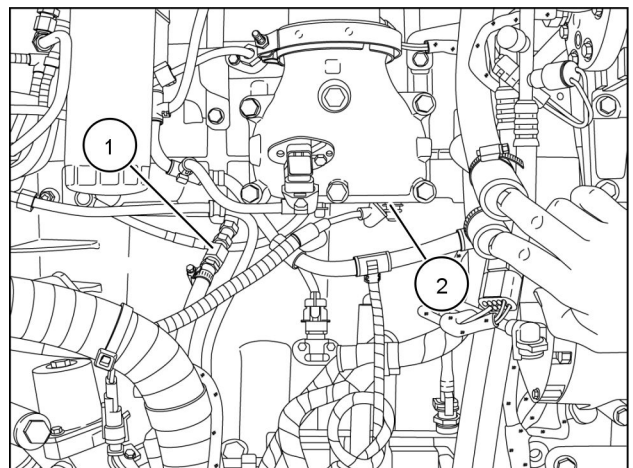

RCPH11WHL042AAR 24

39. Connect the engine control module electrical connector (1).

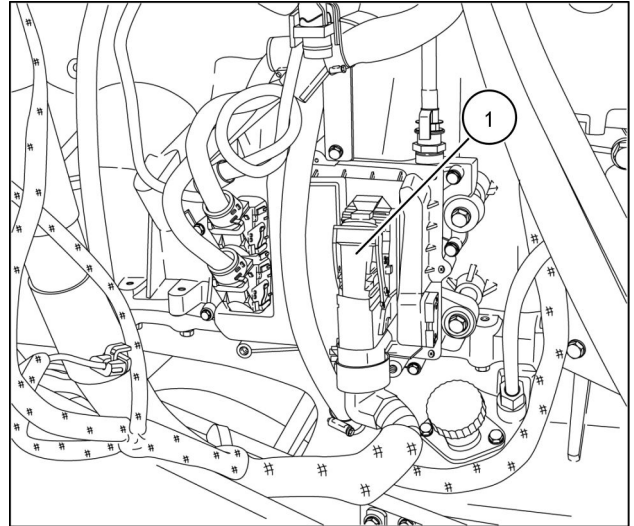

RCPH11WHL041AAR 25

40. Install the crank case ventilation/fuel filter bracket assembly.

41. Connect the following on the crank case ventilation/fuel filter assembly:

- Fuel pump electrical connector
- Water sensor electrical connector
- Ground wire
- Wire harness P-clamp
- Crankcase filter inlet hose
- Crankcase filter outlet hose
- Crankcase filter oil return hose
- Fuel pump inlet tube
- Fuel pump outlet tube

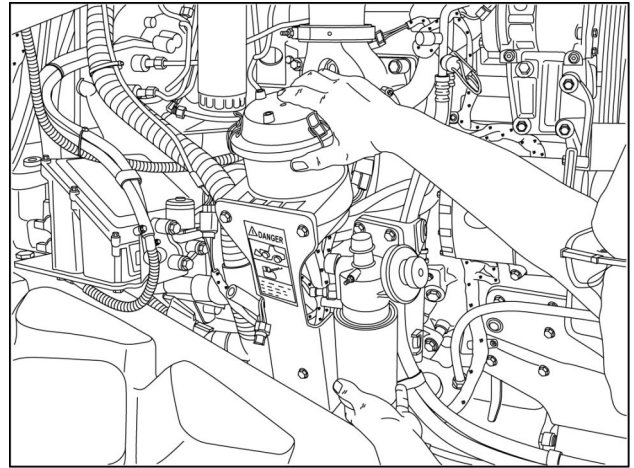

RCPH11WHL040AAR 26

42. Connect the starter battery cables (1) and starter switch wire (2).

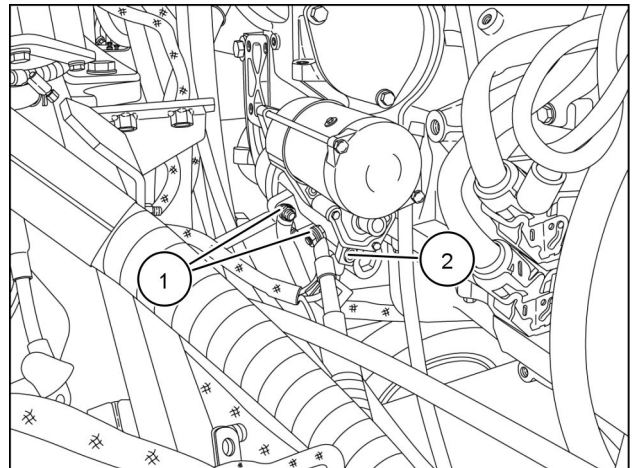

RCPH11WHL049AAR 27



Suggest:

If the above button click is invalid.

Please download this document

first, and then click the above link

to download the complete manual.

Thank you so much for reading

43. Connect the hood lift strut electrical connector **(2)**.
44. Slip the oil dipstick tube **(1)** through the engine wall. Install the dipstick tube P-clamp **(3)**.

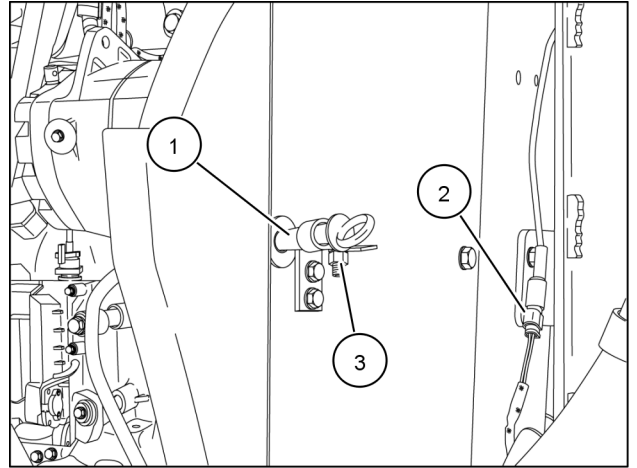

RCPH11WHL015AAR 28

45. Install the bulkheads **(2)**.
46. Install the after air cooler tube **(1)**.

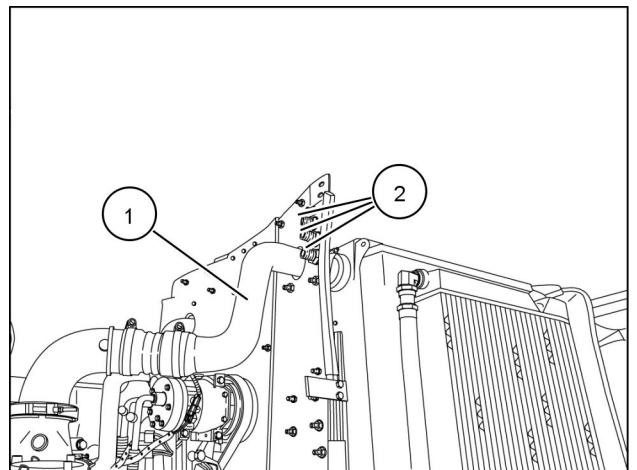

RCPH11WHL014AAR 29

47. Install the hydraulic lines **(1)**.

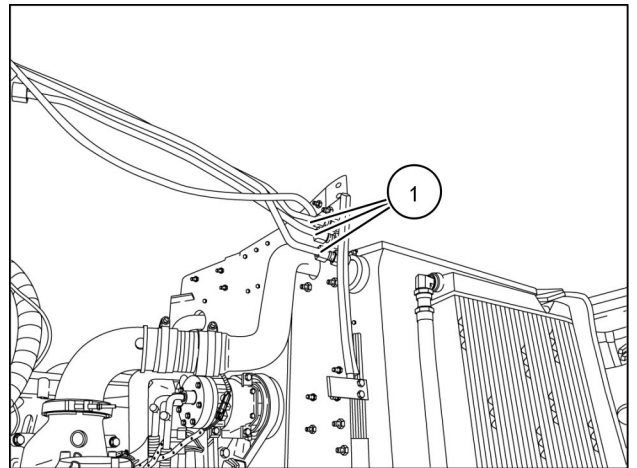

RCPH11WHL013AAR 30

<https://www.ebooklibonline.com>

Hello dear friend!

Thank you very much for reading.

Enter the link into your browser.

The full manual is available for immediate download.

<https://www.ebooklibonline.com>