

# 980 EXCAVATOR

## TABLE OF CONTENTS

SERIES/SECTION	SECTION NO.	FORM NO.
10 SERIES - GENERAL		
General Information .....	10	
General Engine Specifications .....	1010	9-75906
Detailed Specifications .....	1020	9-76875
20 SERIES - ENGINE		
Engine Diagnosis .....	2001	9-76365
Engine Tuneup .....	2002	9-76379
Cylinder Head, Valve Train and Camshaft .....	2015	9-76166
Cylinder Block, Sleeves, Pistons and Rods .....	2025	9-76176
Crankshaft, Main Bearings, Flywheel and Oil Seals .....	2035	9-76187
Lubrication System, Oil Pump, Heat Exchanger and Oil Flow Diagrams .....	2046	9-76805
Cooling System, Water Manifolds, Water Pump and Thermostats .....	2055	9-76337
Turbocharger Failure Analysis .....	2565	9-78235
30 SERIES - FUEL SYSTEM		
Fuel System and Filters .....	3010	9-75297
Robert Bosch Fuel Injection Pump .....	3012	9-74937
Roosa Master Fuel Injectors .....	3013	9-74959
40 SERIES - HYDRAULICS		
Hydraulic Specifications, Diagram, Trouble Shooting, and Adjustments .....	42	9-73475
Hydraulic Pump and Motors .....	43	9-73475
Hydraulic Control Valves, Relief Valves, Check Valves and Swivel .....	44	9-73475
Hydraulic Cylinders .....	46	9-73475
50 SERIES - TRACK AND SUSPENSION		
Track and Suspension .....	50	9-73475
60 SERIES - POWER TRAIN		
Final Drive Transmission .....	64	9-73475
Swing Reducer and Brake .....	65	9-73475
Turntable Bearing .....	66	9-73475
70 SERIES - BRAKES		
Track Drive Brake .....	71	9-73475
80 SERIES - ELECTRICAL		
Electrical .....	81	9-73475

**SECTION**

**10**

**GENERAL INFORMATION**

**<https://www.ebooklibonline.com>**

Hello dear friend!

Thank you very much for reading.

Enter the link into your browser.

The full manual is available for immediate download.

**<https://www.ebooklibonline.com>**

## TABLE OF CONTENTS

Engine Specifications . . . . .	2
Overall Unit Dimensions . . . . .	3
Track Dimensions . . . . .	4-5
Boom and Dipper Dimensions . . . . .	5
Electrical System . . . . .	6
Hydraulic Valves Pressure Settings . . . . .	6
Scheduled Maintenance Chart . . . . .	7-9
Lubricants and Fluids Charts . . . . .	10
Pictorial Listing of Lubrication Fittings . . . . .	11-17
Checking Engine Oil . . . . .	18
Changing Engine Oil and Filter . . . . .	18-19
Diesel Fuel System . . . . .	19-20

## ENGINE SPECIFICATIONS

### GENERAL

Make and Model	Case 504BDT
Type	.6 cylinder, 4 stroke cycle, valve-in-lead turbo charged
Horsepower	
Maximum Gross (See Note 1)	165 H.P. @ 2200 RPM
*SAE net flywheel (See Note 2)	150 H.P. @ 2200 RPM
Bore and Stroke	4-5/8" (117.5 mm) x 5" (127 mm)
Piston Displacement	504 cubic inches (8.26 liters)
Firing Order	1-5-3-6-2-4
Compression Ratio	15.8 to 1
Engine Speeds	
No load governed speed	2330-2370 RPM
Full load rated	2200 RPM
Engine idling speed	750-800 RPM
Exhaust Valve Rotators	Positive Type
Torque, Pounds-Feet, SAE	445 @ 1500 RPM
*Valve Tappet Clearance (Exhaust) (Hot)	.020" (0.508 mm)
(Cold)	.025" (0.635 mm)
(Intake) (Hot & Cold)	.015" (0.381 mm)

\*Hot Settings are made after the engine has operated at thermostat controlled temperatures

### PISTON AND CONNECTING RODS

Rings per piston	3
Number of Compression rings	2
Number of Oil rings	1
Type Pins	Full floating type
Type Bearing	Replaceable Precision, Steel back, Copper-Lead or Aluminum Alloy Liners

### MAIN BEARINGS

Number of Bearings	7
Type of Bearings	Replaceable Precision Steel back, Copper-Lead or Aluminum Alloy Liners

### ENGINE LUBRICATING SYSTEM

Crankcase Capacity (W/O Filter Change)	15 Quarts
With Filter Change	17 Quarts
Oil Pressure	45 to 60 PSI with Engine Warm and Operating at Rated Engine Speed
Type System	Pressure and Spray Circulation
Oil Pump	Gear Type
Oil Filter	Full Flow Spin on Type

### FUEL SYSTEM

Pump Timing	.30° BTC Static
Recommended Fuel	No. 2 Diesel
Fuel Pressure @ Injection Pump	25 PSI (1.75 Kg/cm <sup>2</sup> )
Nozzel Opening Pressure	3150 to 3250 PSI
Fuel Tank	75 gals (283.87L)
Radiator Pressure Cap	7 P.S.I.(.49 Kg/cm <sup>2</sup> )
Engine Oil Pressure	45 to 60 PSI (3.16 kg/cm <sup>2</sup> to 3.87 Kgs/cm <sup>2</sup> )

#### NOTE1

Manufacturer's rating of maximum engine horsepower at flywheel without accessories. Fuel set at maximum quantity for this application.

#### NOTE2

SAE net flywheel horsepower of engine as applied to this vehicle when equipped with all accessories.

## OVERALL UNIT DIMENSIONS

A. Width of revolving super-structure	A. 94-1/2" A. 2400.3 mm
B. Maximum height of cab above grade.	B. 9' 9" B. 2971.8 mm
C. Swing clearance (radius of rear end from axis of rotation)	C. 9' 6-1/2" C. 2908.3 mm
D. Minimum clearance under crawler base to grade	D. 15" Hitch Pin 22" To Undercarriage D. 381 mm to Hitch 558.8 mm to undercarriage.
E. Height of boom foot pin above grade.	E. 77.43" Less Leveler 85.38" With Leveler E. 1965.96 mm Less Leveler 2166.6 mm With Leveler
G. Distance under counterweight to grade.	G. 42.30" Less Leveler 50.25" With Leveler G. 1074.4 mm Less Leveler 1275.08 mm With Leveler
H. Overall width when running boards are used.	H. 94-1/2" H. 2400.3 mm
J. Overall length of crawler	J. 13' 5" J. 4089.4 mm
K <sub>1</sub> . Overall width of crawler retracted	K <sub>1</sub> . 9' 4" With 24" Shoes 9' 10" With 30" Shoes K <sub>1</sub> . 2844.8 mm With 609.6 mm Shoes 2,997.2 mm With 762 mm Shoes
K <sub>2</sub> . Overall width of crawler extended.	K <sub>2</sub> . 10' 4" with 24" pads K <sub>2</sub> . 10' 10" with 30" pads
L. Width of crawler tread shoes	L. 24" or 30" L. 609.6 mm or 762 mm

## TRACK DIMENSIONS

<p>A. Track Rollers</p> <ol style="list-style-type: none"> <li>1. Construction</li> <li>2. Number of rollers - top each side</li> <li>3. Number of rollers - bottom each side</li> <li>4. Roller centers - top</li> <li>5. Roller spacing - bottom</li> <li>6. Roller diameter</li> </ol>	<p>A.</p> <ol style="list-style-type: none"> <li>1. Cast and Machined</li> <li>2. 2</li> <li>3. 9</li> <li>4. 40.5"</li> <li>4. 1028.7 mm</li> <li>5. 11.65"</li> <li>5. 295.9 mm</li> <li>6. 9.50"</li> <li>6. 241.3 mm</li> </ol>
<p>B. Track Shoes</p> <ol style="list-style-type: none"> <li>1. Number used (one track)</li> <li>2. Track shoe width               <ol style="list-style-type: none"> <li>a. standard</li> <li>b. optional</li> </ol> </li> <li>3. Type - track shoe               <ol style="list-style-type: none"> <li>a. standard</li> <li>b. optional</li> </ol> </li> </ol>	<p>B.</p> <ol style="list-style-type: none"> <li>1. 49</li> <li>2.           <ol style="list-style-type: none"> <li>a. 24"</li> <li>a. 609.6 mm</li> <li>b. 30"</li> <li>b. 762 mm</li> </ol> </li> <li>3.           <ol style="list-style-type: none"> <li>a. 3 Bar Grouser</li> <li>b. 3 Bar Grouser</li> </ol> </li> </ol>
<p>C. Idlers - Track</p> <ol style="list-style-type: none"> <li>1. Construction</li> <li>2. Numbers Used - each side</li> <li>3. Idler centers</li> </ol>	<p>C.</p> <ol style="list-style-type: none"> <li>1. Cast and machined</li> <li>2. 1</li> <li>3. 130.40"</li> <li>3. 3312.1 mm</li> </ol>
<p>II. Additional Carrier Data</p>	<p>II. Additional Carrier Data</p>
<p>A. Track Gauge</p> <ol style="list-style-type: none"> <li>1. Narrow</li> <li>2. Wide</li> </ol>	<p>A.</p> <ol style="list-style-type: none"> <li>1. 7' 4"</li> <li>2. 8' 4"</li> <li>1. 2235.2 mm</li> <li>2. 2540 mm</li> </ol>
<p>B. Length of Track on Ground</p> <p>C. Area of Ground Contact with:</p> <ol style="list-style-type: none"> <li>1. 24" shoes</li> <li>2. 30" shoes</li> </ol>	<p>B. 13' 8"</p> <p>B. 3352.8 mm</p> <p>C.</p> <ol style="list-style-type: none"> <li>1. 6,336 sq. in.</li> <li>1. 40,879 cm<sup>2</sup></li> <li>2. 7,920 sq. in.</li> <li>2. 51,099 cm<sup>2</sup></li> </ol>

### TRACK DIMENSIONS

D. Ground Pressure - Pound/Square Inch 1. 24" shoes 2. 30" shoes	D. 1. 6.7 P.S.I. 2. 5.7 P.S.I.
E. Track Adjustment	E. Hydraulic
F. Overall length in Travel Position	F. 29' 4" F. 8940.8 mm
III. Structural Components	III. Structural Components
A. Carrier Frame 1. Construction	A. 1. Welded Plate
B. Turntable 1. Construction	B. 1. Welded Plate
C. Boom 1. Construction	C. 1. Welded Box 2. Welded Plate

### BOOM and DIPPER DIMENSIONS

	Boom Pin Upper Hole		Boom Pin Lower Hole	
	Dipperstick		Dipperstick	
	9'	10'5	9'	10.5'
Maximum reach at grade level	30' 3" 9220.2 mm	31' 7" 9626.6 mm	30' 3" 9220.2 mm	31' 7" 9626.6 mm
Maximum digging depth to tip of teeth	20' 8" 6299.2 mm	21' 10" 6654 mm	14' 9" 4495.8 mm	16' 1" 4902.2 mm
Maximum depth of cut for 8 foot level bottom - straight	20' 4" 6196.6 mm	21' 6" 6553 mm	14' 5" 4392.3 mm	15' 9" 4800.6 mm
Maximum height of attachment	23' 3" 7086.6 mm	23' 4" 7112 mm	30' 10" 9398 mm	31' 3" 9525 mm

## ELECTRICAL SYSTEM

IV. Electrical System	IV. Electrical System
A. System Voltage	A. 24 volt
B. Alternator Amps	B. 35 Amp
C. Battery Amp Hours Rating 1. Number used	C. 180 Amps Hrs @ 20 hr. rating 1. 2

## HYDRAULIC VALVE PRESSURE SETTINGS

Main Valve	2500 P.S.I.
Crowd - High Pressure Secondaries	3000 P.S.I.
Hoist - High Pressure Secondaries	3000 P.S.I.
Tool - High Pressure Secondaries	3000 P.S.I.
Track - High Pressure Secondaries	2250 P.S.I.
Swing - High Pressure Secondaries	3000 P.S.I.
Swing Cushion Valve	1350 P.S.I.

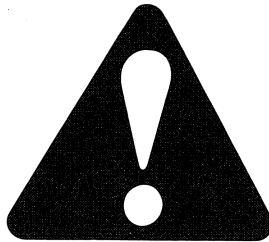

**KNOW THE AREA AROUND YOUR EXCAVATOR.  
CHECK FOR CLEARANCE BEFORE SWINGING.**

## SCHEDULED MAINTENANCE CHART

This section contains the routine and periodic maintenance information necessary to keep your machine in top operating condition. Following the maintenance chart is the easiest and most economical means of assuring many hours of satisfactory operation.

**NOTE:**

Grease fittings which are exposed to severe conditions of dust, water or mud should be lubricated more often than suggested in the Maintenance Chart.

INTERVAL	SERVICE	LUBRICANT/PART
Run - in (after 20 Hours)	Replace 33 Micron Hydraulic Oil Filter Element, clean 100 Mesh Screens	Use non-flammable solvent to clean Mesh Screens
	Change Engine Oil and Oil Filters	See Chart on Page 10.
	CAUTION: When ambient temperature changes be certain to change oil as specified in Lubricants and Fluids Chart page 10.	
Every 10 hours or Daily	Grease Leveler Fittings	Multipurpose No. 1 Lithium "Soap Base" grease - below 32° F.
	Grease Boom Fittings	
	Grease Crawler Drive Pillow Blocks	Multipurpose No. 2 Lithium "Soap Base" grease - above 32° F.
	Check Hydraulic Oil Tank Level	To check level - Crowd in Curl Tool, Bucket on Level Ground
	Track Rollers	Check for Leakage Lifetime Lubricated; no scheduled maintenance required (HDM 30W)
	Drain water from Fuel Tank	Open petcock under turntable
	Check Engine Oil Level	Level between full and fill lines on dipstick

### SCHEDULED MAINTENANCE CHART

INTERVAL	SERVICE	LUBRICANT/PART
Every 10 Hours or Daily	Check Engine Coolant Level	1/2 permanent type (ethylene glycol) anti-freeze, 1/2 water
	Fill Fuel Tank	No. 2 Diesel Fuel
	Lubricate Turntable Open Gear	Use Open Gear Lubricant
	Operator's Compartment	Clean thoroughly check cotter pins on control rod linkage
After 1st 50 hours or 1st week of operation	Check torques on all turntable bearing capscrews	See Turntable Capscrew Maintenance Section 66
Every 50 hours or Weekly	Check fluid level in batteries	Distilled water
	Check V-belt deflection on engine	1/2" deflection
	Clean Fuel Strainer	Use non-flammable solvent
	Lubricate Control Linkage	Multipurpose No. 1 Lithium "Soap Base" grease - below 32° F.
	Lubricate Turntable Bearing	Multipurpose No. 2 Lithium "Soap Base" grease - above 32°F.
	Check Oil Level in Final Drive Transmissions	SAE 90, API-GL4
	Check Oil Level in Swing Reducer	SAE 90, API-GL4
	Excavator Tracks	Check and Adjust tension as necessary
	Check Air Filter Element	Clean and replace as necessary
Every 100 hours	Change Engine Oil	See Lubricants and Fluids Chart Page 10
Every 200 Hours	Change Engine Oil Filter Elements	See Lubricants and Fluids Chart Page 10

### SCHEDULED MAINTENANCE CHART

INTERVAL	SERVICE	LUBRICANT/PART
Every 300 hours or 6 weeks	Check torques on all turntable bearing bolts	See Turntable Capscrew Maintenance Section 66
Every 500 hours or Two Months	Change Hydraulic Oil Filter Element, Clean Mesh Screens	See Lubricants and Fluids Chart Use a non-flammable solvent to clean mesh screens.
Every 1500 hours or Semi-Annually	Drain and Refill Track Drive Transmissions	SAE 90, API-GL4
	Drain and Refill Swing Reducer	SAE 90, API-GL4
	Drain and Refill Hydraulic Oil Tank	Case TCH fluid
	Clean Battery and Connecting Posts	Use a solution of baking soda and water.
	Drain and Flush Radiator and Cooling System. Install Fresh Coolant	1/2 Permanent type (ethylene glycol) anti-freeze 1/2 water
Every 3000 Hours or Yearly	Have Authorized Case Dealer inspect, clean and service Turbocharger	

## LUBRICANTS AND FLUIDS CHART

	CAPACITY	RECOMMENDATIONS
Turntable Open Gear		Mobil Mobiltac-E Texaco Crater Compound Sunoco 407 Compound B Sohio Sohitac No. 1 - or equivalent
Engine Crankcase	15 U.S. qts. 10 Imp. qts.	Engine oil meeting the following specifications. Case HDM or MIL- L-2104 C including SAE J 183 designations SD and CD
Engine crankcase (with filter change)  See Note Below	17 U.S. qts. 14.17 Imp. qts.	Above 32 <sup>o</sup> F.      SAE 30 10 <sup>o</sup> - 50 <sup>o</sup> SAE 20W Below 40 <sup>o</sup> SAE 10W
Complete Hydraulic System  Hydraulic Tank	50 U.S. Gals. 41.66 Imp. Gals.  18 U.S. Gals 15 Imp. Gals	Case TCH Fluid or as Alternate; SAE 10W (System Temperatures 0 <sup>o</sup> F. to 180 <sup>o</sup> F.) and SAE 20-20 W (System Temperatures 50 <sup>o</sup> F. to 210 <sup>o</sup> F.) Artic Conditions - 5W to 5W-20
Fuel Tank	75 U.S. Gals. 62.5 Imp. Gals.	No. 2 Diesel Fuel
Drive Transmission	1 U.S. Gal. .834 Imp. Gal.	SAE 90, API-GL4 MIL-L-2105-B
Swing Gearbox	11 pints 1.14 Imp. Gals.	SAE 90, API - GL4 MIL-L-2105-B
Pressure Fittings		Multipurpose No. 1 Lithium "Soap Base" grease - below 32 <sup>o</sup> F. Multipurpose No. 2 Lithium "Soap Base" grease - above 32 <sup>o</sup> F.
Engine Coolant	11 U.S. Gals. 9.16 Imp. Gals.	1/2 high boiling point permanent (ethylene glycol) type anti-freeze 1/2 water (protects to - 34 <sup>o</sup> F.)

NOTE: It is extremely important that a stable, high quality engine lubricating oil be selected for use in the Case Diesel Engine. It is also extremely important that the correct weight (SAE Viscosity Rating) of oil be selected for the prevailing air temperature. This assures you that the oil will remain fluid or free flowing within the specified temperature ranges.

## PICTORIAL LISTING OF LUBRICATION FITTINGS

### LUBRICATION INTERVAL

Follow suggested intervals except where unit is operating in severe or abnormal conditions. In these cases, lubricate more often.

### RECOMMENDED LUBRICANT

Below 32° Multipurpose or No. 1 lithium base grease

Above 32° Multipurpose or No. 2 lithium base grease

**DRIVE SPROCKET PILLOW BLOCKS:** Lubricate daily or sooner, depending on working conditions. If working in water or extreme mud conditions, flush pillow blocks twice daily with pressure gun until contaminated grease disappears. See Figure 1.

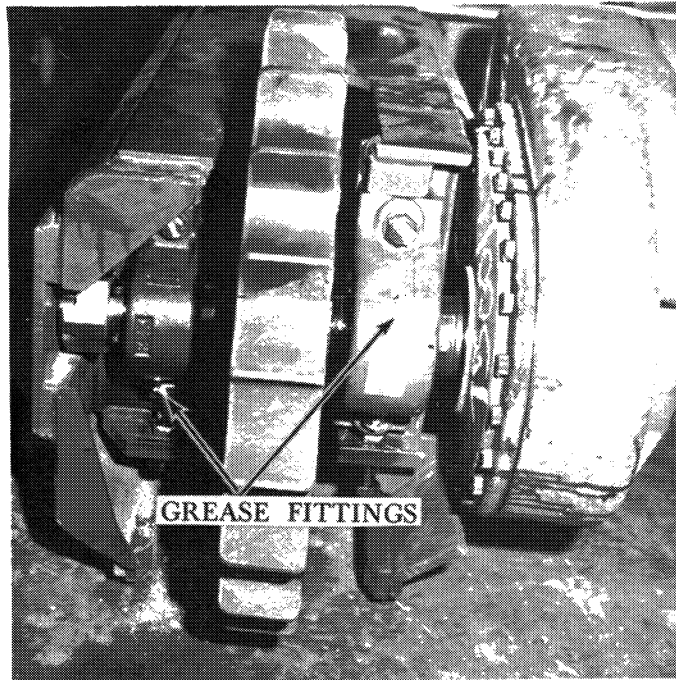

Figure 1. Grease Fitting on Drive Sprocket Pillow Blocks

**BOOM AND CYLINDERS:** Fittings are located at positions indicated in Figures 10 through 15. Lubricate all fittings daily.

**LEVELER CYLINDERS AND PIVOTS:** Lubricate daily. Make sure Leveler Locks are in position for safety while lubricating. Figures 5 and 9 show locations of fittings on Cylinders and Pivots.

**TURNTABLE BEARING:** There are four fittings located at 90 degree angles around the turntable bearing. Lubricate weekly with a lithium "Soap Base" Grease No. 1 below 32 degrees F; No. 2 above 32 degrees F.

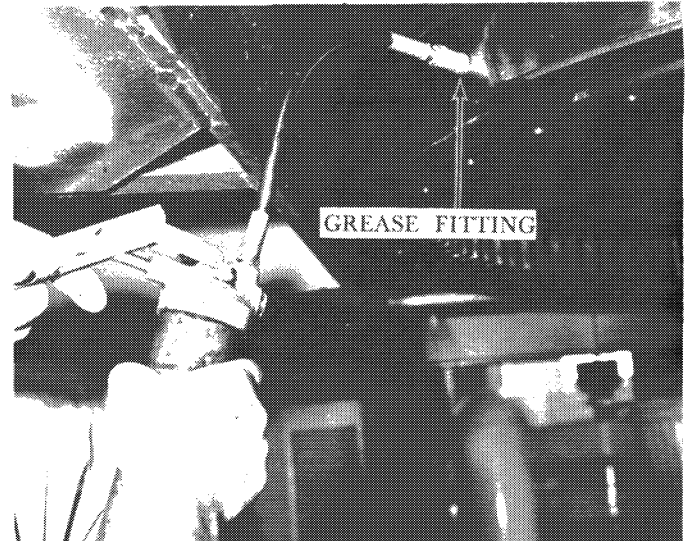

Figure 2. Grease Fitting Turntable Bearing (one of four)

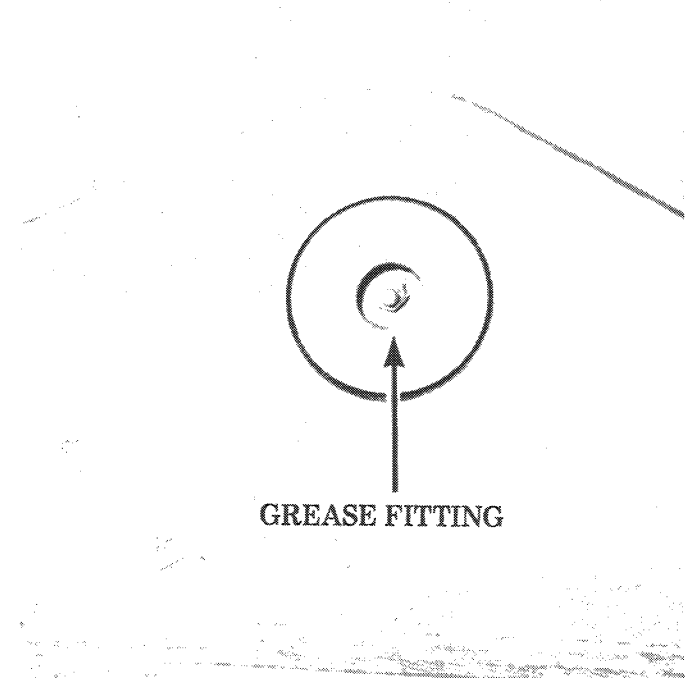

Figure 3. Location of Grease Fitting on One of Two Turntable Pivots.

**CONTROL LINKAGE AND BELLCRANKS:** Lubricate all fittings weekly. Use extension on grease gun to reach fittings under turntable.

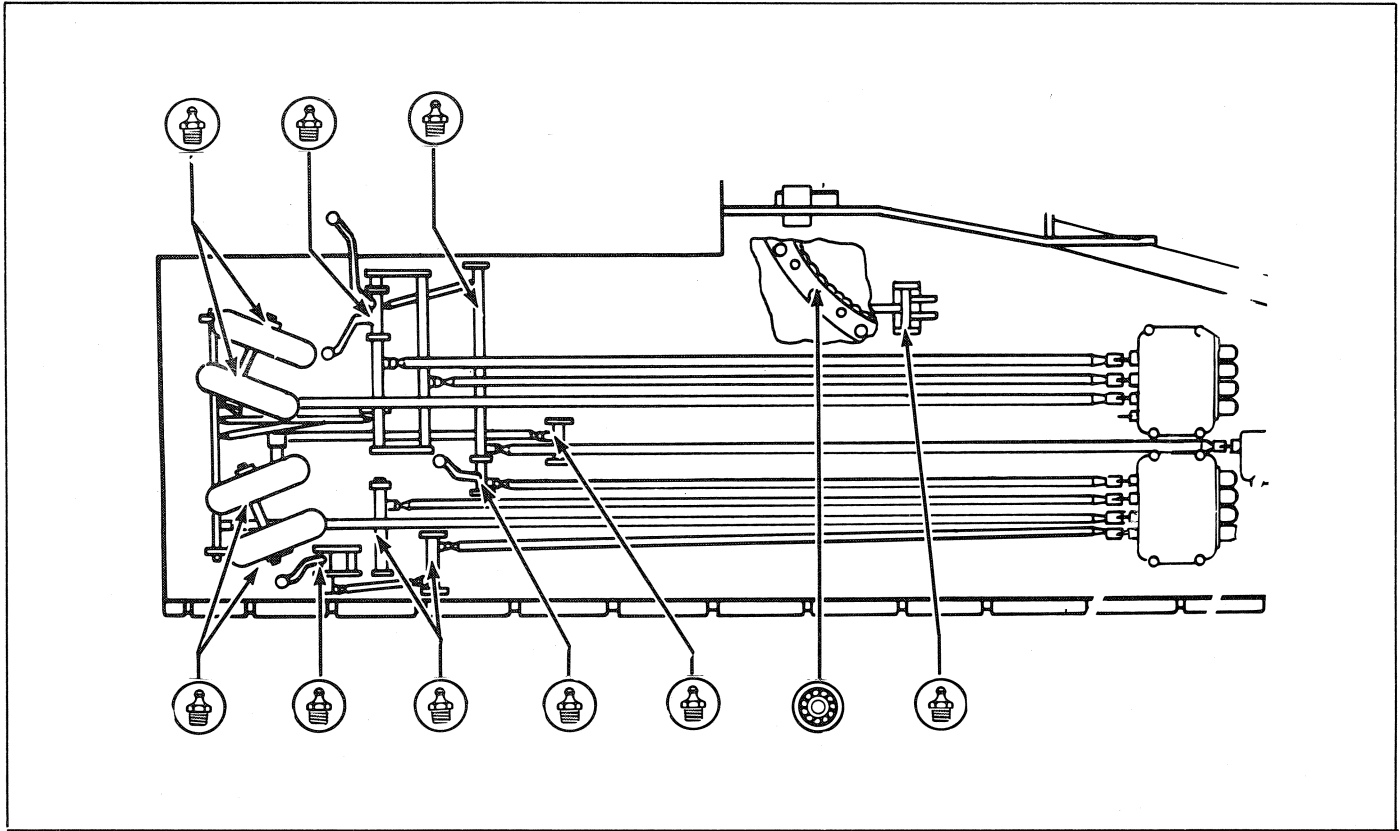

Figure 4. Control Linkage and Bellcrank Grease Fittings.

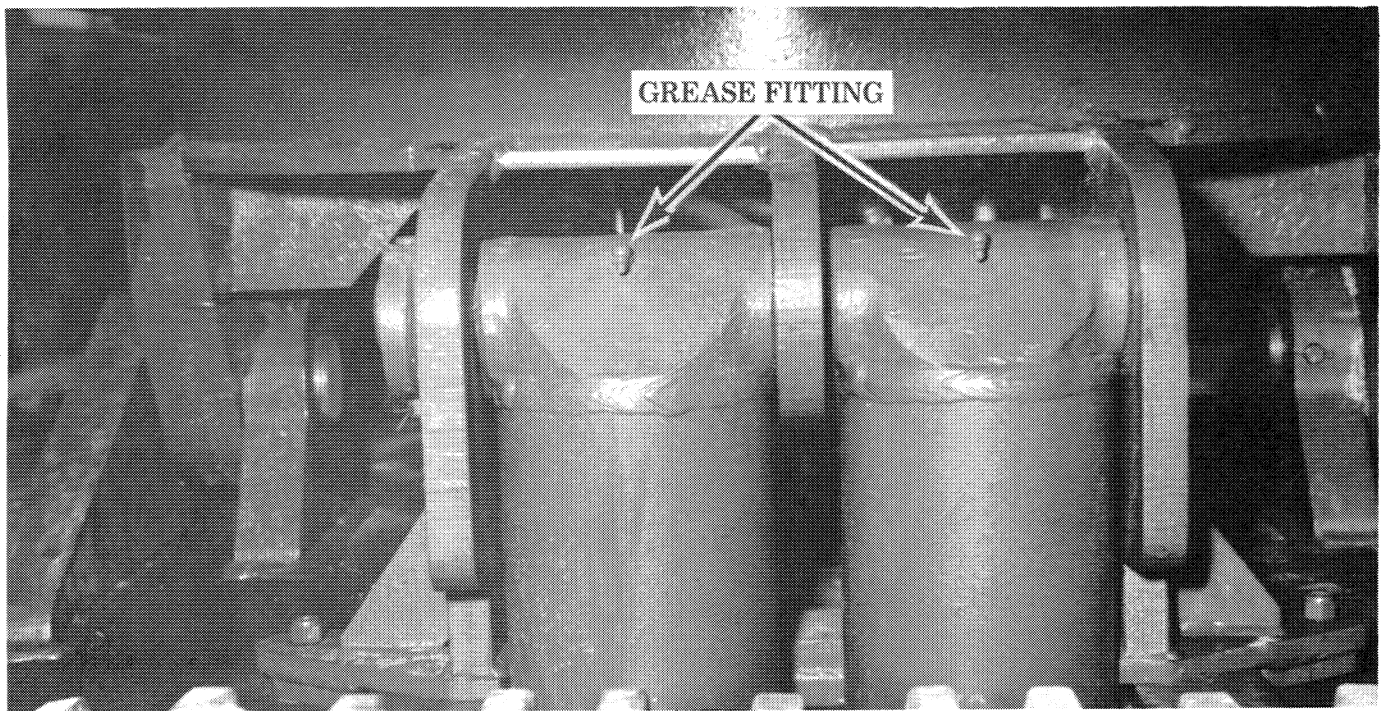

Figure 5. Grease Fitting On Top Of Leveler Cylinder.  
One On Each End Of Cylinder - two Cylinders.

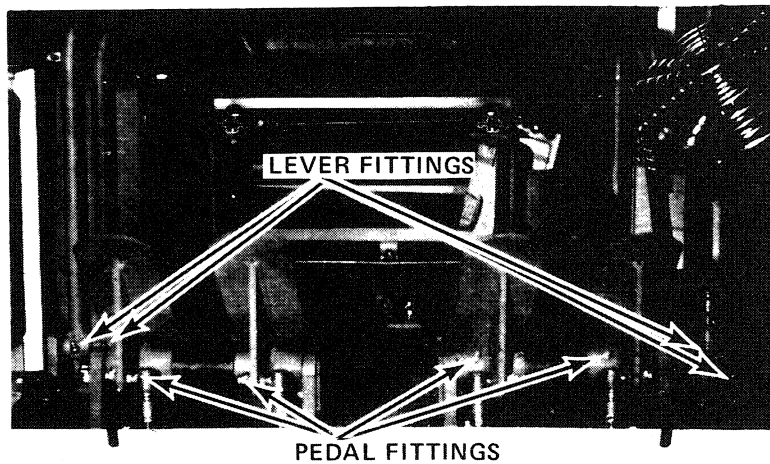

Figure 6. Grease Fitting on Pedal and Lever Linkage



Figure 7. Grease Fittings on Detent Bellcrank and Leveler Control Rod Linkage

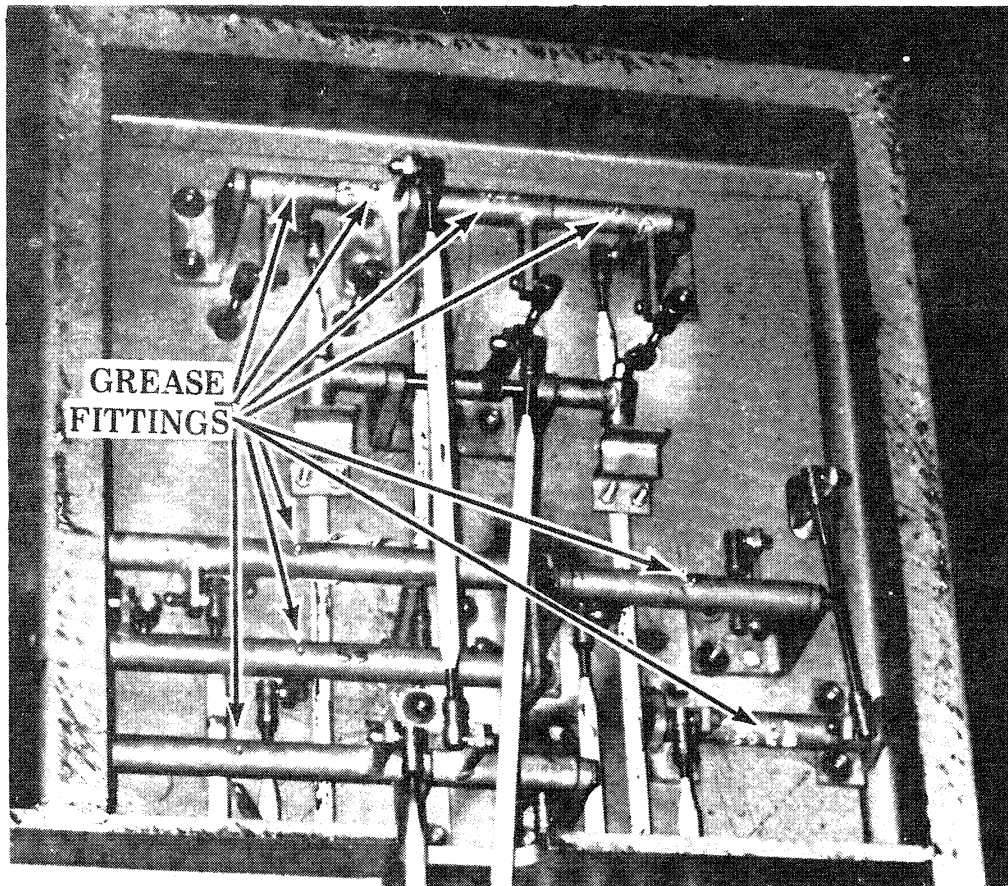

Figure 8. Grease Fittings on Bellcranks Under Operator's Cab.

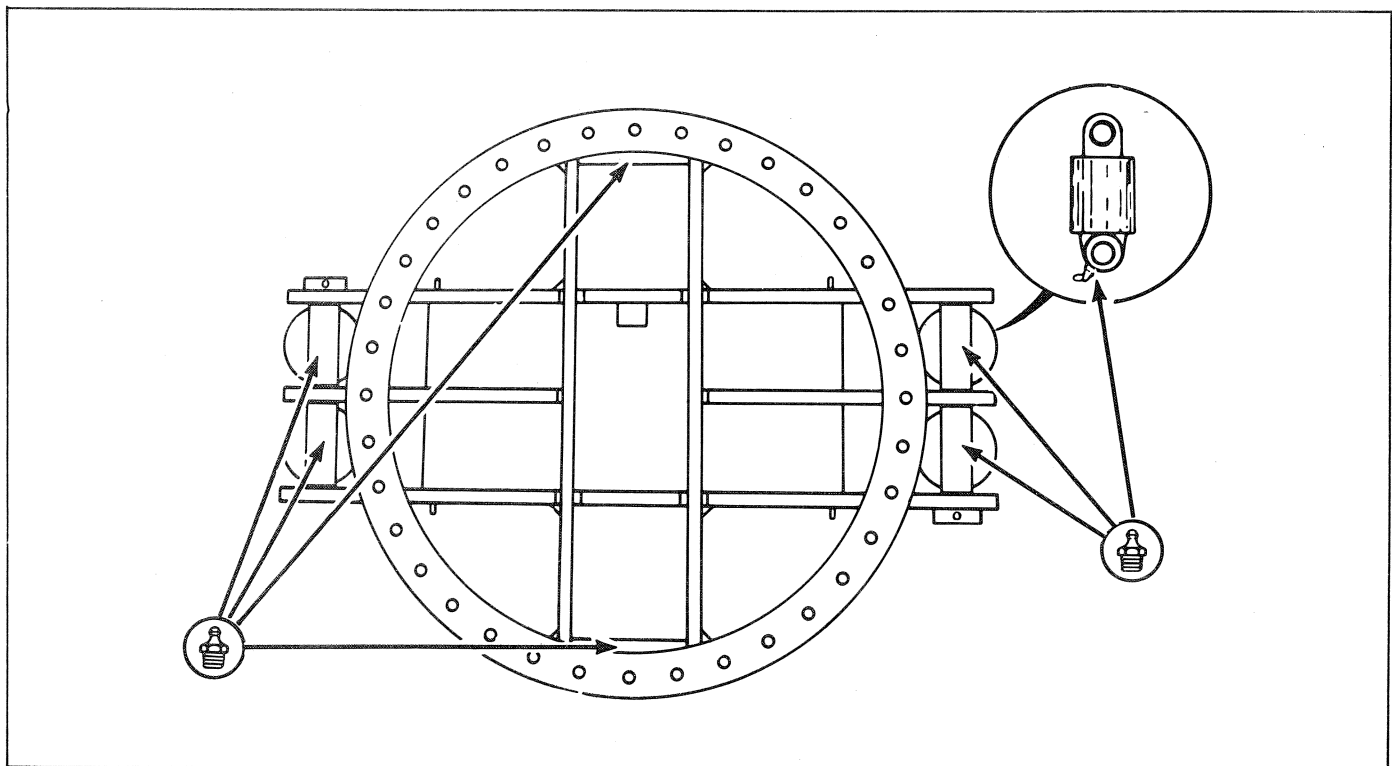

Figure 9. Leveler Grease Fitting Locations.

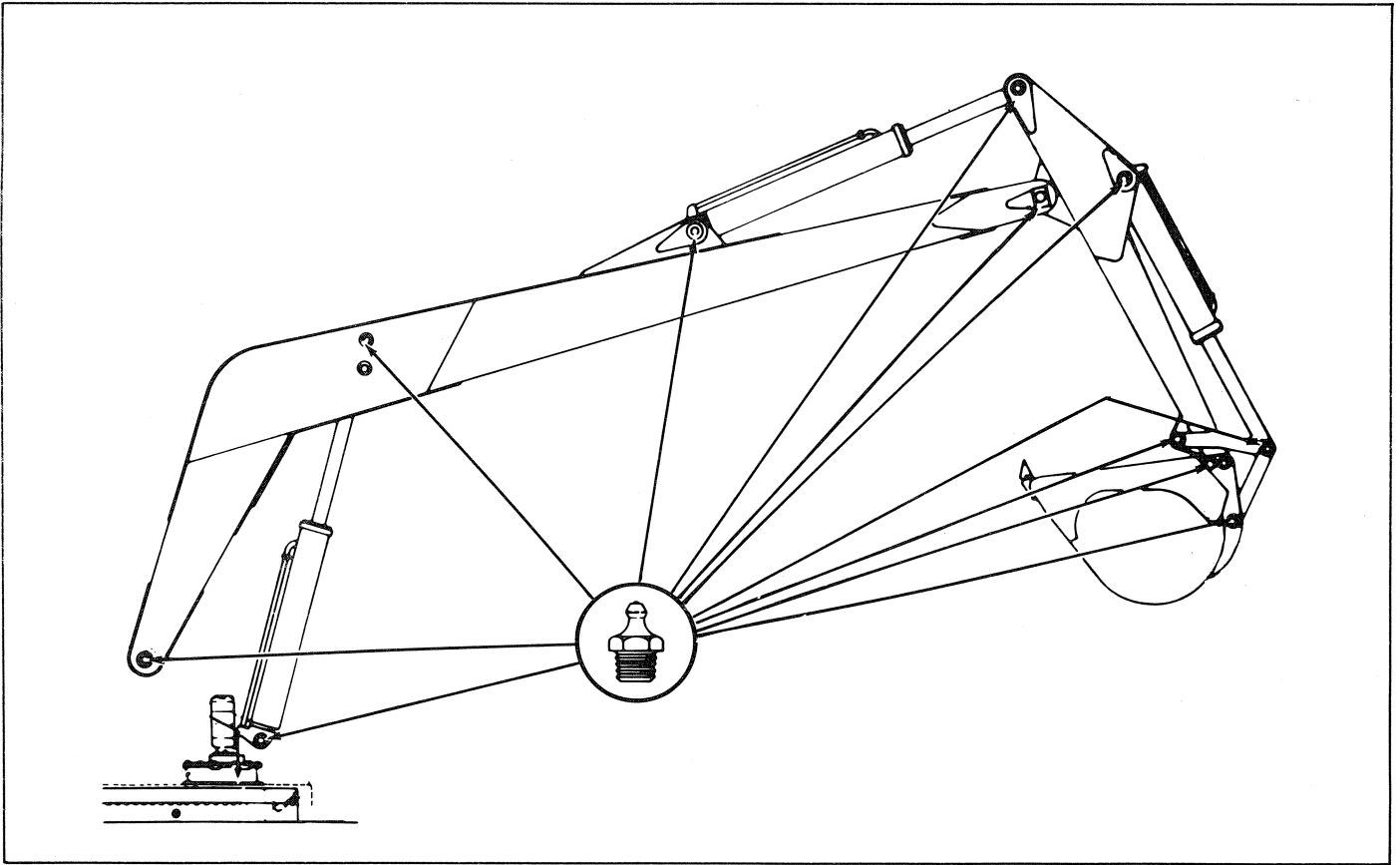

Figure 10. Boom and Cylinders Grease Fittings

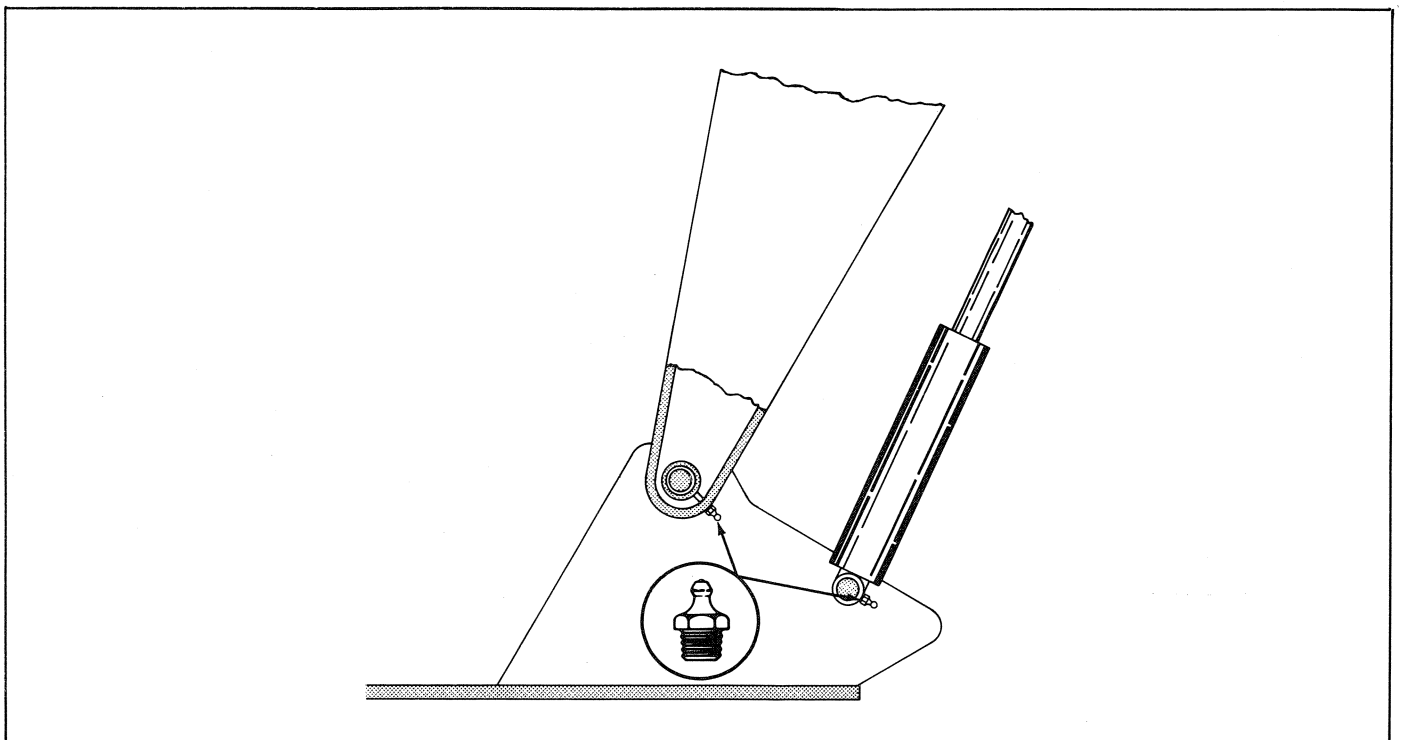

Figure 11. Grease Fittings on Base End of Hoist Cylinder and Main Boom to Mast Hinge Pin.

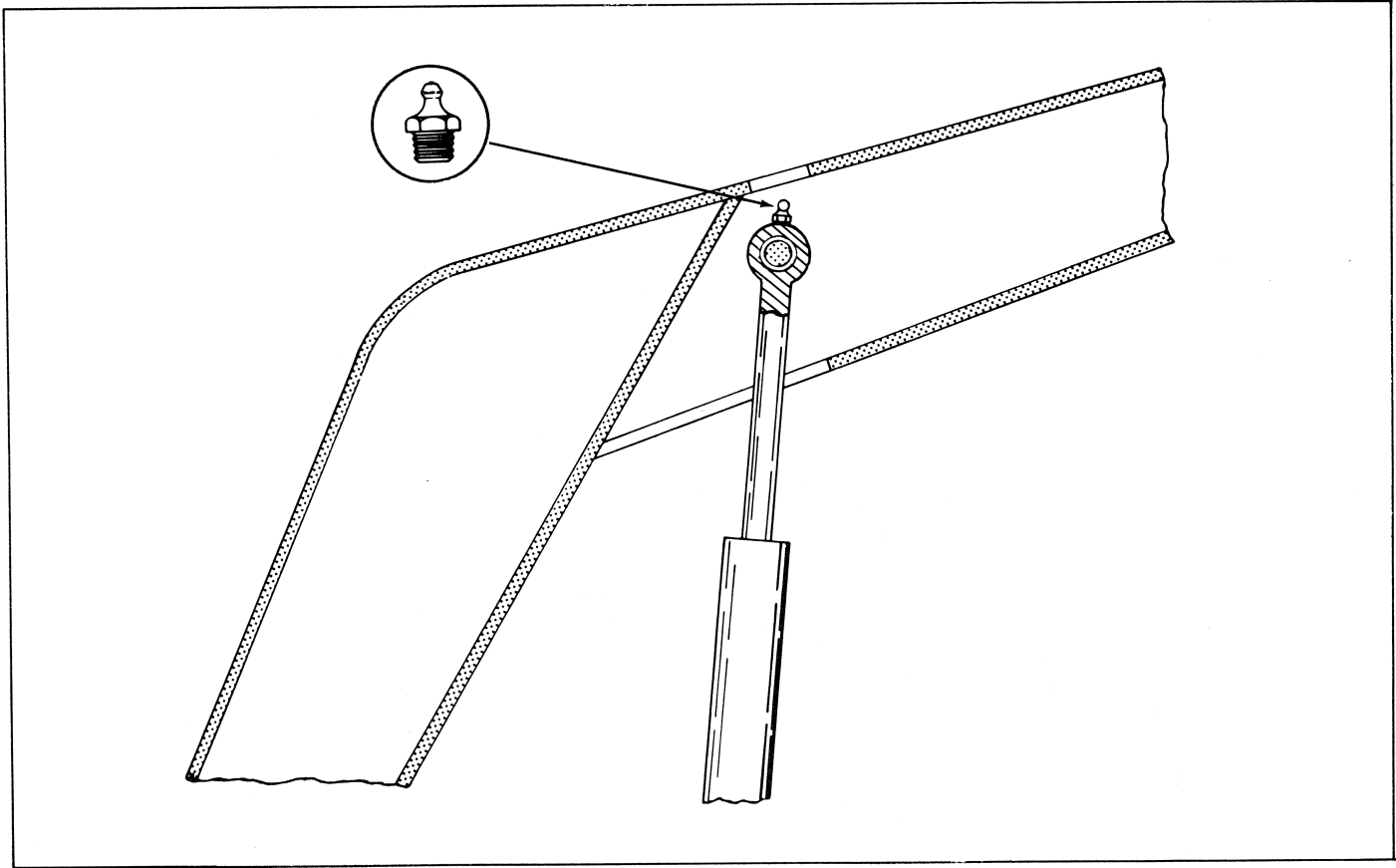

Figure 12. Grease Fitting on Rod End of Hoist Cylinder.  
Access through Hole in top of Beam.

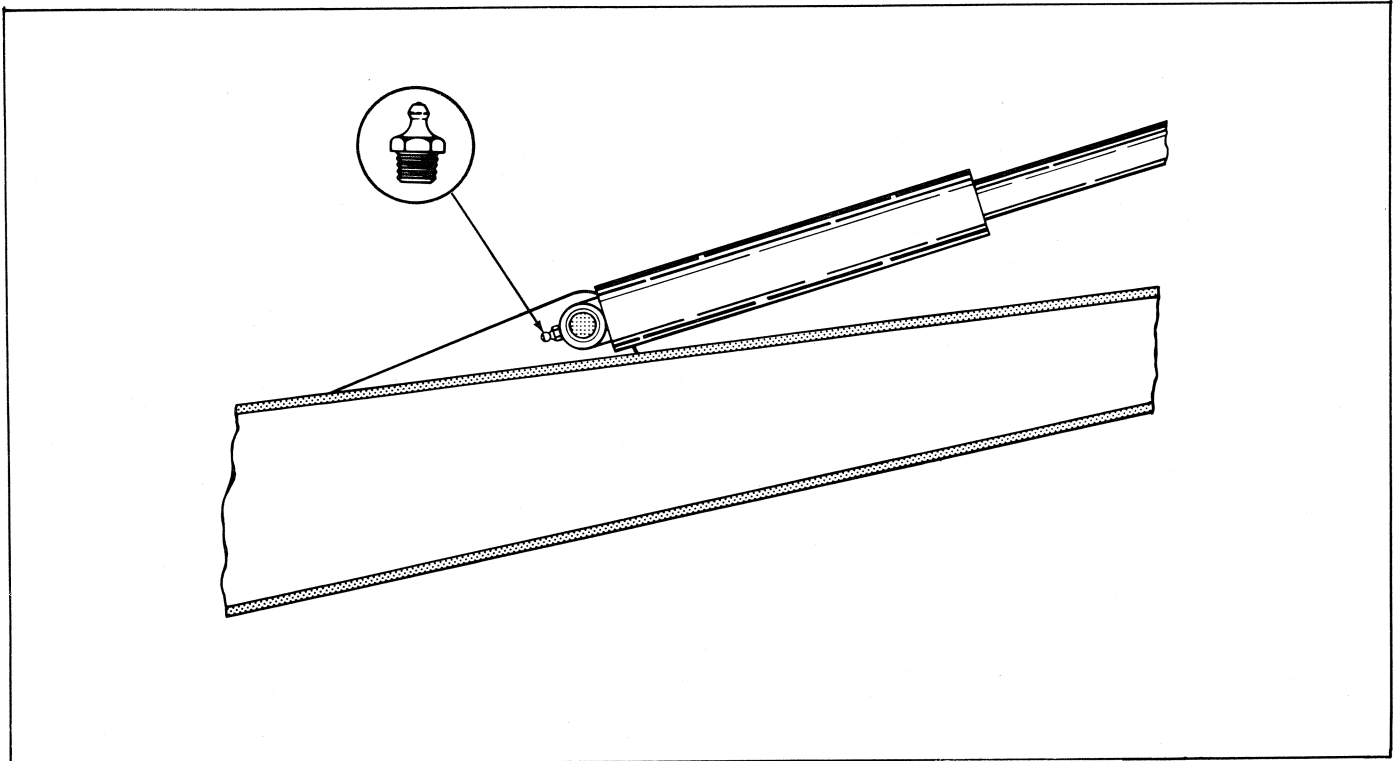

Figure 13. Grease Fitting on Base End of Crowd Cylinder

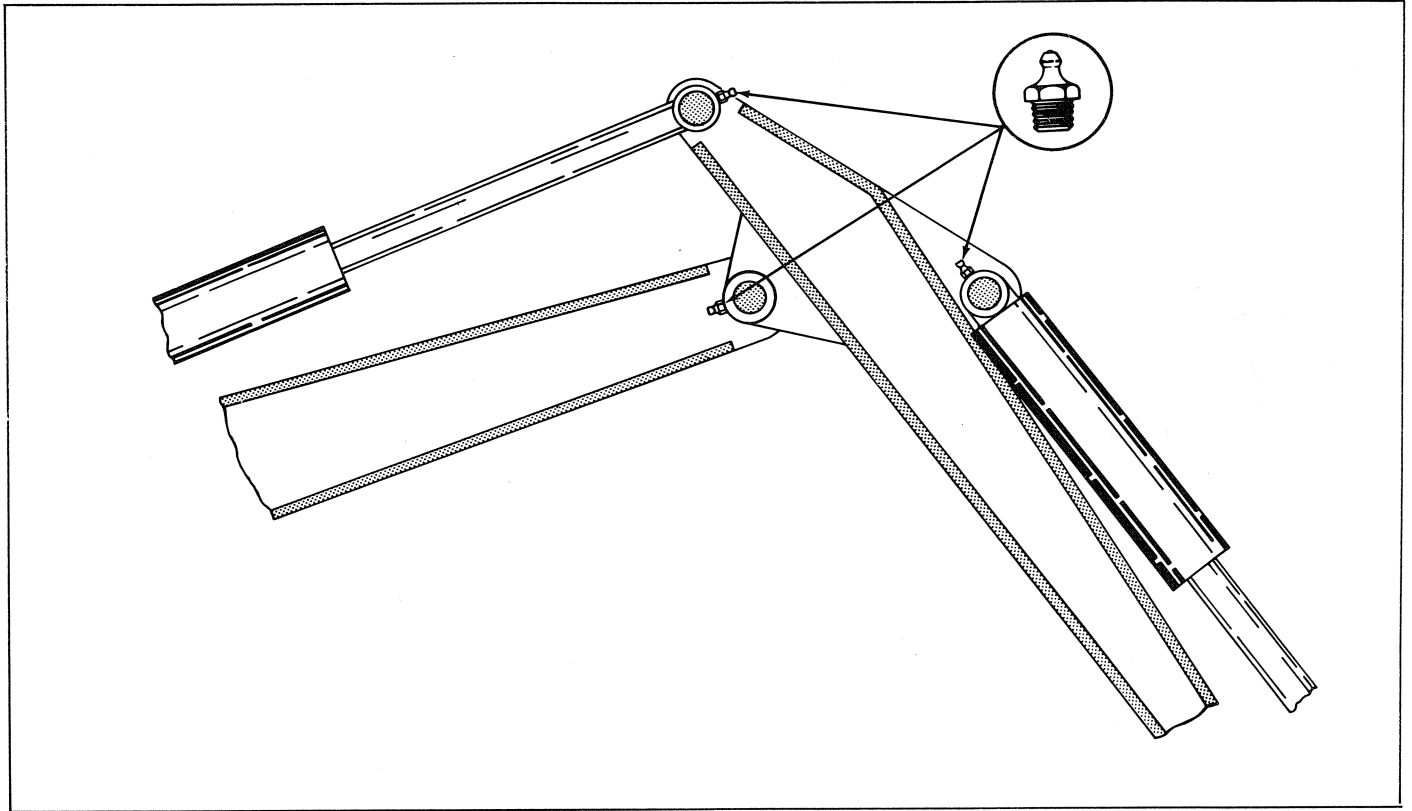

Figure 14. Grease Fitting on Base End of Tool Cylinder, Rod End of Crowd Cylinder and Intermediate to Dipperstick Hinge Pin.

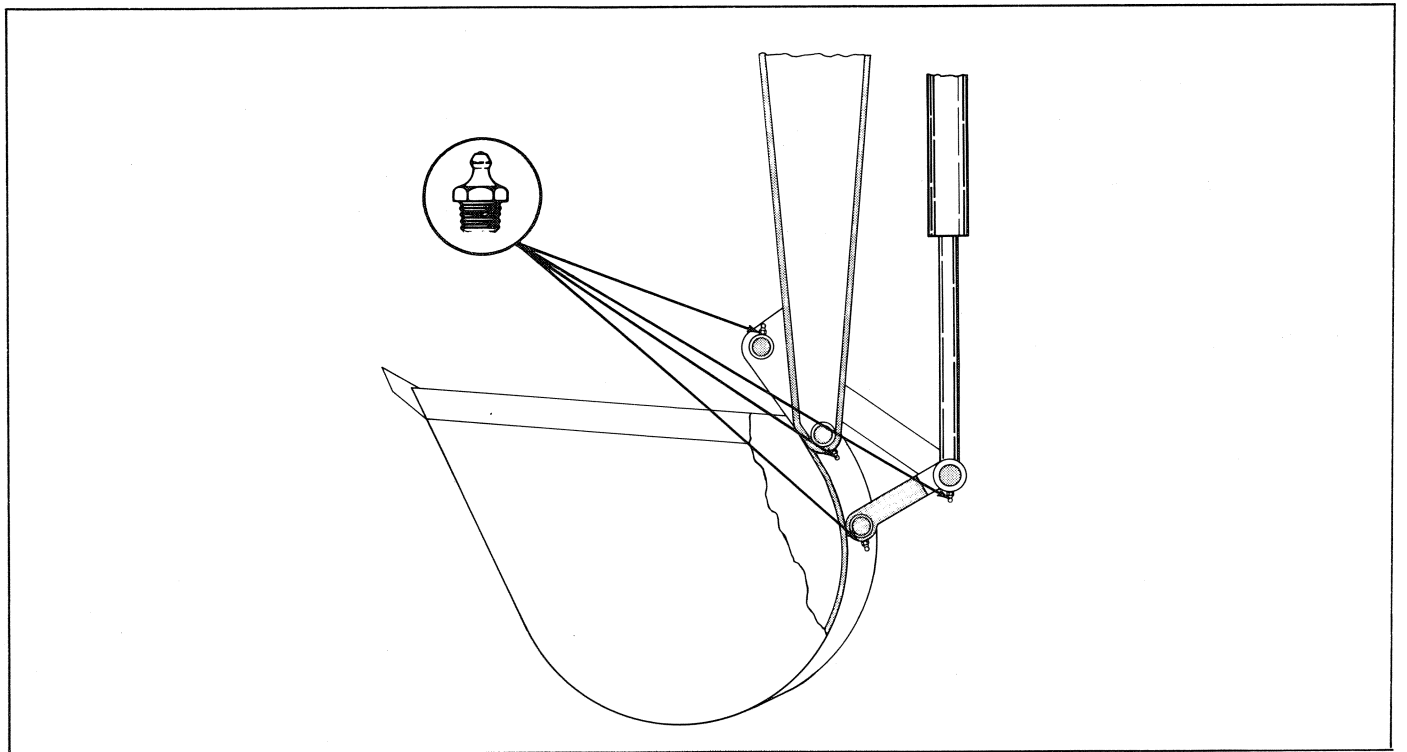

Figure 15. Grease Fittings on Rod End of Tool Cylinder, Dipperstick to Bucket Hinge Pin and Connecting Link Hinge Pins.

## CHECKING ENGINE OIL LEVEL

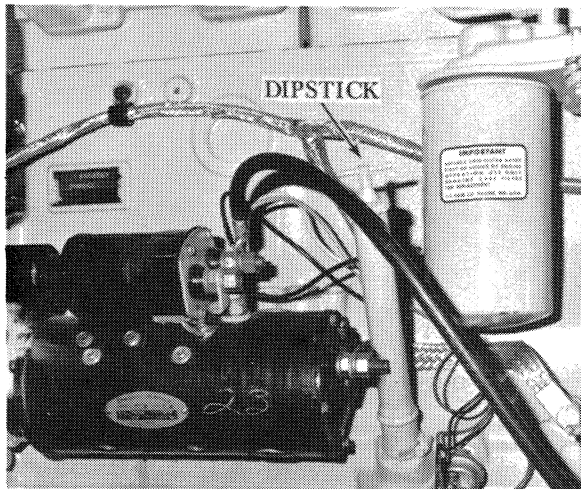
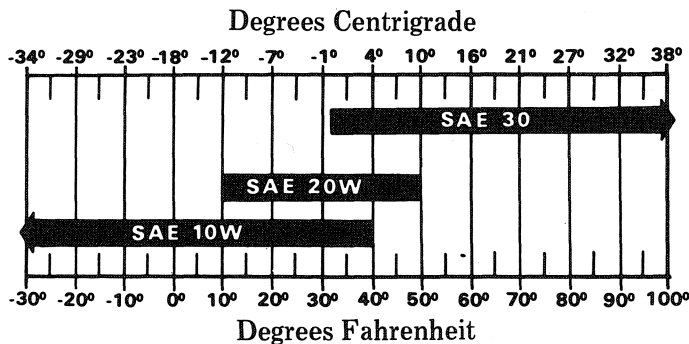

Figure 16. Location of Engine Dipstick

Check engine oil level daily, using the dipstick on the right hand side of the engine, Figure 16. To reach dipstick, open door at rear of excavator and reach inside shroud. Oil level should be between FULL and LOW marks on the dipstick. Do not check oil level when engine is running. Be sure the turntable is level before checking level of oil.

## PREVAILING AIR TEMPERATURE



## ENGINE LUBRICATING OIL SERVICE DESIGNATION

Use only Case HDM or SAE J183, CD and SD Service Classification Oil in the engine crankcase that has passed the required engine performance test for the MIL-L2104C Rating.

## CHANGING ENGINE OIL.

### Change Interval

After the first 20 hours of operation and each 100 hours or every 2 weeks, whichever occurs first. If operating conditions are severe, oil should be changed more often.

### NOTE:

**OIL SHOULD BE DRAINED WHILE HOT FOR THE MOST THOROUGH REMOVAL OF CONTAMINANTS.**

1. Remove the oil pan drain plug and drain engine crankcase of oil.
2. After oil is drained reinstall oil pan drain plug.
3. Select a high quality oil that meets all specifications in chart on page 10 and the oil service classification mentioned earlier.
3. Refill with 15 measured U.S. quarts of oil to the crankcase.

**IMPORTANT:** Make certain the excavator is setting on level ground to assure an accurate oil level check.

4. With the fuel shut off control pulled to the "off" position and ignition switch on, press the start button, cranking the engine until the engine oil pressure gauge pointer reaches the green zone or for a maximum of 30 seconds. Push the fuel shut off control down to the "run" position, then press the start button until engine starts and run for 5 minutes at approximately 1000 RPM. This will assure that adequate lubrication has reached the turbocharger bearings before applying full throttle or load. Shut the engine off and check oil level with dipstick. Check filter area for any oil leaks. Add oil if necessary.

## CHANGING ENGINE OIL FILTERS

### Change Interval

After the first 20 hours of operation and every 200 hours thereafter.

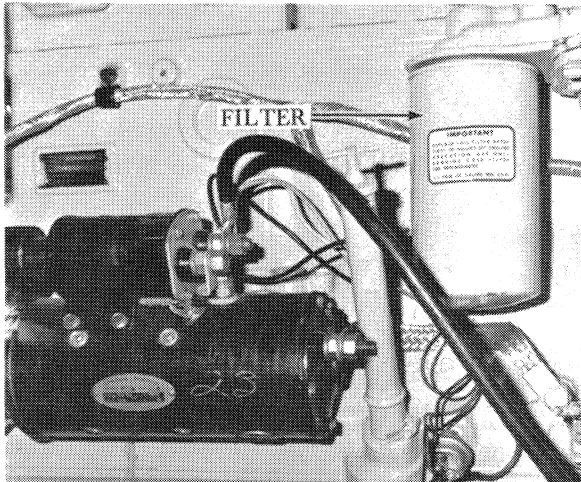

Figure 17. Engine Oil Filters

1. Remove the oil pan drain plug and drain engine crankcase of all oil.
2. With a clamp type wrench, remove the two oil filters.
3. Apply a coat of clean oil to the gasket of the new CASE oil filters. Install each filter by turning until gasket contact is made. Hand tighten 1/4 to 1/2 of a turn.

4. Loosen each filter approximately 1 full turn. Retighten until gasket contact is made. Hand tighten 1/4 to 1/2 turn to obtain the proper seal.
5. Install the oil pan drain plugs and torque to 18 to 20 ft./lbs. (2.5 to 2.9 m-kg.).
6. Add 17 measured U.S. quarts of new engine oil.

**IMPORTANT:** Make certain the excavator is setting on level ground to assure an accurate oil level check.

7. With the fuel shut off control pulled to the "off" position and ignition switch on, press the start button, cranking the engine until the engine oil pressure gauge pointer reaches the green zone or for a maximum of 30 seconds. Push the fuel shut off control down to the "run" position, then press the start button until engine starts and run for 5 minutes at approximately 1000 RPM. This will assure that adequate lubrication has reached the turbocharger bearings before applying full throttle or load. Shut the engine off and check oil level with dipstick. Check filter area for any oil leaks. Add oil if necessary.

Genuine Case Filter Elements are obtainable from your Authorized Case Dealer. Do not use substitutes. **IMPORTANT: CHANGE THE OIL FILTERS AT THE RECOMMENDED TIME INTERVALS.**

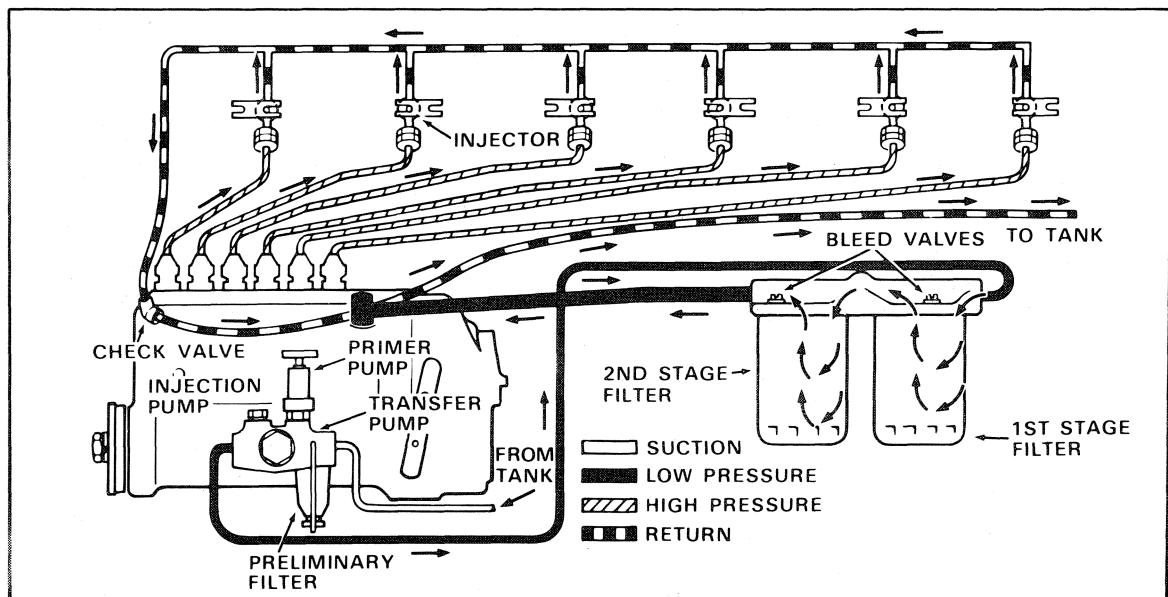

Figure 18. Fuel Flow and Return to Tank

## DIESEL FUEL SYSTEM

The fuel system in your Case Diesel Excavator consists of a fuel supply tank, fuel filters and the fuel injection equipment. The service life of the fuel injection equipment on your diesel engine is wholly dependent upon the cleanliness of the fuel. If abrasives or water are permitted to reach the highly precisioned moving parts in the injection equipment, rapid wear will result and poor performance may be expected. To prevent abrasives or water from reaching the injection equipment, it is important that you use clean fuel and regularly service the filters and water trap as described in this manual.

### GENERAL DESCRIPTION

Figure 18 illustrates the fuel flow from the engine fuel supply tank to the combustion chambers and excess fuel return to fuel tank. The fuel system is composed of the following components:

### FUEL STORAGE

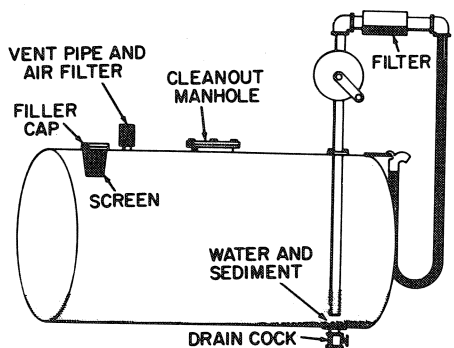

**Figure 19. Recommended Fuel Storage Tank**

The importance of proper fuel handling and storage cannot be too strongly emphasized. Storage tanks must be kept free from rust, scale, sediment, and other foreign matter that will contaminate fuel. The specific gravity of diesel fuel is such that foreign matter will remain in suspension for long periods of time. For this reason, it is important that diesel fuel be allowed to settle for at least 24 hours without being disturbed in any way before it is put into the fuel tank. The motion of an excavator in operation will keep the foreign matter in contaminated fuel from settling and some of this material will be transported into the fuel injection system. The abrasive action of fuel contaminants on precision parts in the injection pump and spray nozzles will result in a loss of engine

power and eventual failure of these parts.

Any water that might find its way into diesel fuel, either through moisture condensation or by other means, will unite with sulphur to form destructive acids. For this reason, it is also highly important that special attention be paid to methods of protecting diesel fuel from water while storing and handling.

### FUEL STORAGE TANK

1. A rust-proof storage tank similar to the one illustrated in Figure 19 provides a good permanent storage tank. Main storage tanks of this type should be provided with a shelter so fuel can be kept as cool as possible.
2. A pump equipped with a long hose and nozzle and mounted in the top of the storage tank will provide a means of transferring fuel directly to the crawler fuel tank without contamination resulting from the use of dirty buckets or funnels.

The intake pipe of such a pump should be raised high enough from the bottom of the tank so as to avoid picking up any water or foreign matter that might have settled there. Fuel also should be filtered between the fuel tank and the dispensing hose.

3. A water trap and drain should be provided in the bottom of any fuel storage tank so that water and foreign matter can be drained daily.
4. A vent pipe and an air filter should be provided in the top of the tank to supply air necessary for extracting the fuel. An air filter protects against foreign matter that would otherwise enter the tank through this opening.
5. A cleanout manhole should be provided in the top of the tank so that the tank can be periodically drained and thoroughly cleaned. The manhole cover should be water tight, and it should only be removed when cleaning the tank.
6. An opening should be provided in the top of the tank for refilling. This opening should be covered with a water tight cap, and a screen should be installed to protect against dirt particles that would otherwise enter when refilling.

# Section 1010

## GENERAL ENGINE SPECIFICATIONS 980 EXCAVATOR

### 504BDT DIESEL ENGINES

THE ENGINE MODEL AND SERIAL NUMBER IS STAMPED ON A PLATE LOCATED ON THE SIDE OF THE ENGINE ABOVE THE CRANKING MOTOR.

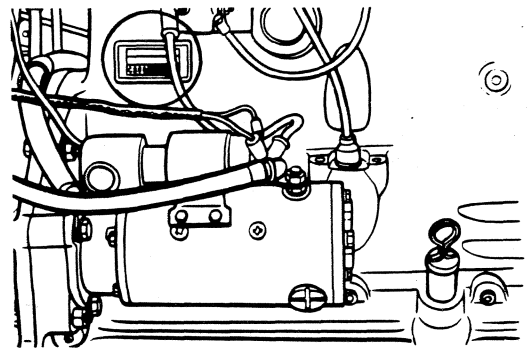

#### General

Type .....	6 Cylinder, 4 Stroke Cycle, Valve-in-Head Turbo-Charged
Firing Order .....	1-5-3-6-2-4
Bore .....	4-5/8 Inches (117.5mm)
Stroke .....	5 Inches (127mm)
Piston Displacement .....	504 Cubic Inches (8 259cm <sup>3</sup> )
Compression Ratio .....	15.8 to 1
No Load Governed Speed .....	2230-2270 RPM
Rated Engine Speed .....	2100 RPM
Engine Idling Speed .....	725 to 775 RPM
Exhaust Valve Rotators .....	Positive Type
*Valve Tappet Clearance (Exhaust) .....	(Hot) .020 Inch (0.508mm) (Cold) .025 Inch (0.635mm)
(Intake) .....	(Hot and Cold) .015 Inch (0.381mm)

\*Hot Settings Are Made After the Engine Has Operated At Thermostat Controlled Temperature For At Least Fifteen Minutes.



**Suggest:**

**If the above button click is invalid.**

**Please download this document**

**first, and then click the above link**

**to download the complete manual.**

**Thank you so much for reading**

## **Piston and Connecting Rods**

Rings per Piston .....	3
Number of Compression Rings .....	2
Number of Oil Rings .....	1
Type Pins .....	Full Floating Type
Type Bearing .....	Replaceable Precision, Steel Back, Copper-Lead or Aluminum Alloy Liners

## **Main Bearings**

Number of Bearings .....	7
Type Bearings ....	Replaceable Precision Steel Back, Copper-Lead or Aluminum Alloy Liners

## **Engine Lubricating System**

Crankcase Capacity .....	12 U.S. Qts., 9.9 Imperial Qts. (11.4 liters)
with Filter Change .....	13 U.S. Qts., 10.8 Imperial Qts. (12.3 liters)
Oil Pressure .....	45 (310 kPa) to 60 (413 kPa) PSI with Engine Warm and Operating at Rated Engine Speed
Type System .....	Pressure and Spray Circulation
Oil Pump .....	Gear Type
Oil Filter .....	Full Flow Spin on Type

## **Fuel System**

Fuel Injection Pump .....	Robert Bosch, Type PES Multiple Plunger
Pump Timing .....	30 Degrees Before Top Dead Center (Port Closing)
Fuel Injectors .....	Pencil Type, Opening Pressure 3200 PSI (22 063 kPa)
Fuel Transfer Pump .....	Plunger Type, Integral Part of Injection Pump
Governor.....	Variable Speed, Fly-Weight Centrifugal Type, Integral Part of Injection Pump
1st Stage Fuel Filter .....	Full Flow Spin on Type
2nd Stage Fuel Filter .....	Full Flow Spin on Type

**<https://www.ebooklibonline.com>**

Hello dear friend!

Thank you very much for reading.

Enter the link into your browser.

The full manual is available for immediate download.

**<https://www.ebooklibonline.com>**