

1. Trim along dashed line.
2. Slide into pocket on Binder Spine.

TYPE 1-4

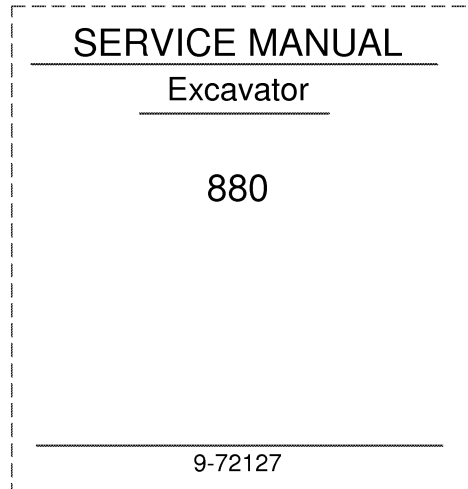

1. Trim along dashed line.
2. Slide into pocket on Binder Spine.

TYPE 1-4

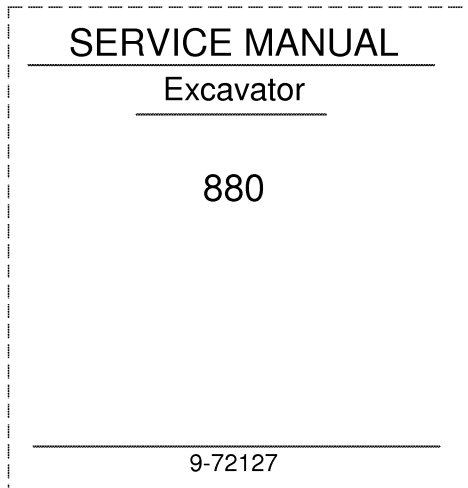

1. Trim along dashed line.
2. Slide into pocket on Binder Spine.

TYPE 1-4

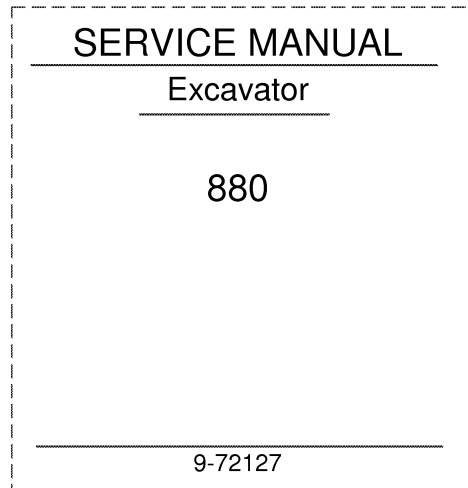

1. Trim along dashed line.
2. Slide into pocket on Binder Spine.

TYPE 1-4

880 EXCAVATOR

TABLE OF CONTENTS

SERIES/SECTION	SECTION NO.	FORM NO.
10 SERIES - GENERAL		
General Engine Specifications - 880 Excavator	11	9-74205
Scheduled Maintenance and Lubrication Guides	13	9-72126
Detailed Engine Specifications	1023	9-78645
20 SERIES - ENGINES		
General Engine Maintenance	21	9-72126
Air Cleaner System Maintenance	24	9-72126
Engine Diagnosis	2001	9-76365
Engine Tune-Up	2002	9-76379
Cylinder Head, Valve Train and Camshaft	2015	9-76166
Cylinder Block, Sleeves, Pistons and Rods	2025	9-76176
Crankshaft, Main Bearings, Flywheel and Oil Seals	2035	9-76187
Lubrication System	2047	9-78667
Cooling System	2055	9-76337
Turbocharger Failure Analysis	2565	9-78235
30 SERIES - FUEL SYSTEM		
Fuel System and Filters	3010	9-75297
Robert Bosch Fuel Injection Pump	3012	9-74937
Roosa Master Fuel Injectors	3013	9-74959
40 SERIES - HYDRAULICS		
Equipment Hydraulics System	41	9-72126
Hydraulic System and Component Trouble Shooting, Testing and Operation	42	9-72126
Main Hydraulic Pump	43	9-72126
Hydraulic Center Swivel and Drive Motors	43A	9-72126
Hydraulic Valves: Control, In-Valve, In-Line and Check	44	9-72126
Hydraulic Cylinders	46	9-80901
Swing Motor and Reduction Gearbox	47	9-72126
50 SERIES - TRACK AND SUSPENSION		
Track and Suspension System	50	9-72126
60 SERIES - DRIVE TRAIN		
Final Drive Transmissions	64	9-72126
70 SERIES - Brakes		
Drive Brake and Swing Brake Assemblies	71	9-72126
80 SERIES - ELECTRICAL		
Electrical System	81	9-72126

Section 11

GENERAL ENGINE SPECIFICATIONS 880 EXCAVATOR

THE MODEL AND ENGINE SERIAL NUMBER IS STAMPED ON A PLATE LOCATED ON THE SIDE OF THE ENGINE ABOVE THE CRANKING MOTOR.

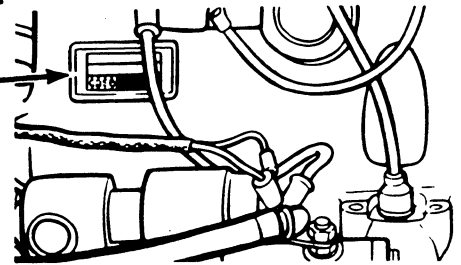

DIESEL ENGINES

General

Type	4 Cylinder, 4 Stroke Cycle, Valve-in-Head Turbo-Charged
Firing Order	1-3-4-2
Bore	4-5/8 Inches
Stroke	5 Inches
Piston Displacement	336 Cubic Inches
Compression Ratio	16.5 to 1
No Load Governed Speed	2385 - 2415 RPM
Rated Engine Speed	2200 RPM
Engine Idling Speed	725 to 775 RPM
Exhaust Valve Rotators	Positive Type
*Valve Tappet Clearance (Exhaust)	(Hot) .020 Inch (Cold) .025 Inch
(Intake)	(Hot and Cold) .015 Inch

*Hot Settings Are Made After the Engine Has Operated At Thermostat Controlled Temperature For At Least Fifteen Minutes.

Piston and Connecting Rods

Rings per Piston	3
Number of Compression Rings	2
Number of Oil Rings	1
Type Pins	Full Floating Type
Type Bearing	Replaceable Precision, Steel Back, Copper-Lead Alloy Liners

Main Bearings

Number of Bearings	5
Type Bearings	Replaceable Precision Steel Back, Copper-Lead Alloy Liners

Engine Lubricating System

Crankcase Capacity	10 Quarts
with Filter Change	11 Quarts
Oil Pressure	45 to 55 Pounds with Engine Warm and Operating at Rated Engine Speed
Type System	Pressure and Spray Circulation
Oil Pump	Gear Type
Oil Filter	Full Flow Spin on Type

Fuel System

Fuel Injection Pump	Robert Bosch, Type PES Multiple Plunger
Pump Timing	30 Degrees Before Top Dead Center (Port Closing)
Fuel Injectors	Pencil Type (Opening Pressure 2800 PSI)
Fuel Transfer Pump	Plunger Type, Integral Part of Injection Pump
Governor	Variable Speed, Fly-Weight Centrifugal Type, Integral Part of Injection Pump
1st Stage Fuel Filter	Full Flow Spin on Type
2nd Stage Fuel Filter	Full Flow Spin on Type

<https://www.ebooklibonline.com>

Hello dear friend!

Thank you very much for reading.

Enter the link into your browser.

The full manual is available for immediate download.

<https://www.ebooklibonline.com>

SECTION
13
SCHEDULED
MAINTENANCE
AND
LUBRICATION GUIDES

General Maintenance of Component Parts and Hydraulic System with Lubrication Guides, Charts and Photographs.

LUBRICANTS and FLUIDS CHART

LUBRICATION POINTS	CAPACITY	RECOMMENDED LUBRICANT
ENGINE CRANKCASE	10 U.S. qts. 8 Imp. qts.	Engine oil meeting following specifications: Service DS; Series 3 & MIL-L-45199
ENGINE CRANKCASE (W/FILTER CHANGE)	11 U.S. qts. 9 Imp. qts.	Above 32° F..... SAE 30 10°-50°..... SAE 20W Below 32°..... SAE 10W
SEE NOTE BELOW		
COMPLETE HYDRAULIC SYSTEM	33 Gals.	Case TCH Fluid or as Alternate: SAE 10W - 0°F, to 180°F, system temperature; SAE 20 - 20W 50°F, to 210°F, system temperature. Arctic Conditions - SAE 5W or 5W-20.
HYDRAULIC TANK	18.0 Gals.	
FUEL TANK	75 Gals.	No. 2 diesel fuel
DRIVE TRANSMISSION	4 quarts	SAE 90, API-GL4
SWING GEARBOX	11 pints	SAE 90, API-GL4
PRESSURE FITTINGS		Multipurpose # 1 Lithium "Soap Base" Grease - below 32° F. Multipurpose # 2 Lithium "Soap Base" Grease - above 32° F.

ENGINE COOLANT

9.5 U.S. gals.
7.6 Imp. gals.

1/2 high boiling point permanent (ethylene glycol) type antifreeze, 1/2 water (protects to -34° F.)

NOTE: It is extremely important that a stable, high quality Engine lubricating oil be selected for use in the Case Diesel Engine. It is also extremely important that the correct weight (SAE Viscosity Rating) of oil be selected for the prevailing air temperature. This assures you that the oil will remain fluid or free flowing within the specified temperature ranges.

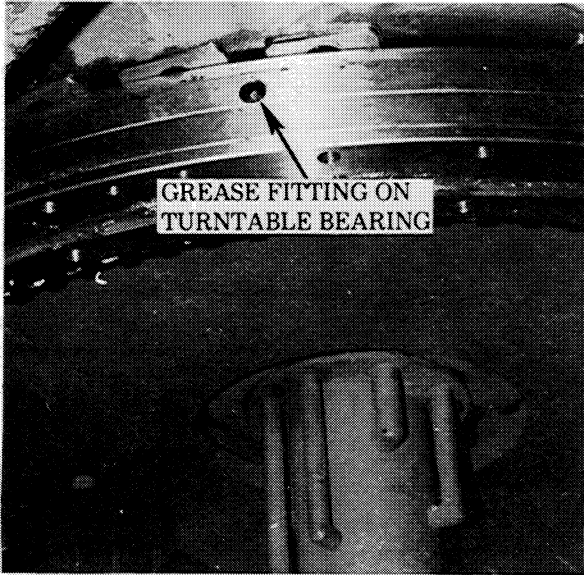

GREASE FITTING ON
TURNABLE BEARING

Figure 1

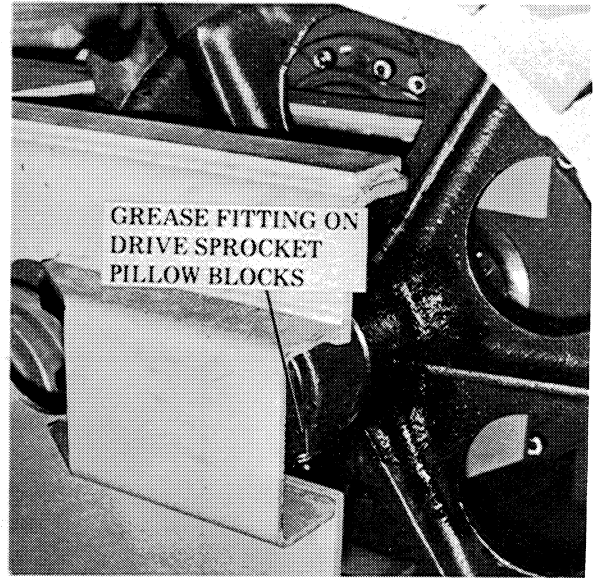

GREASE FITTING ON
DRIVE SPROCKET
PILLOW BLOCKS

Figure 2

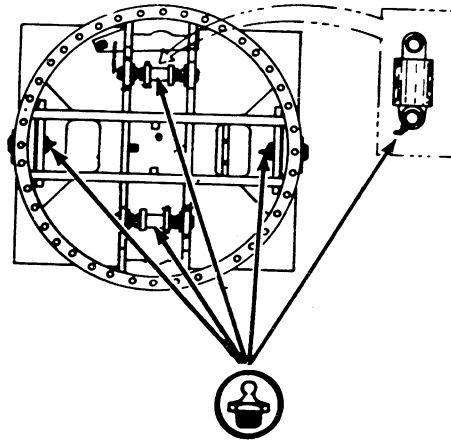
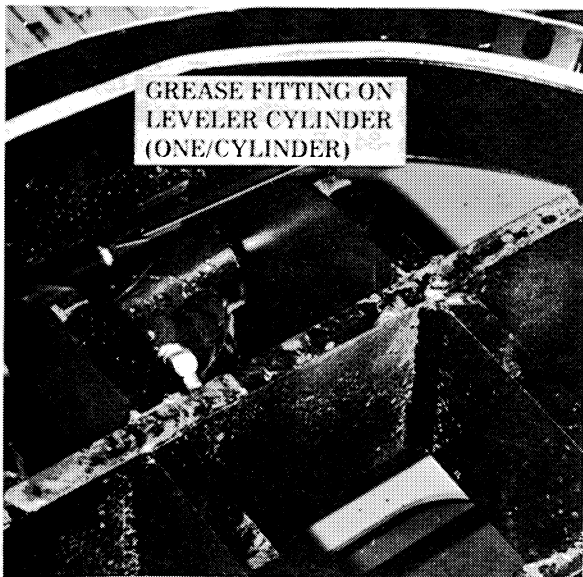
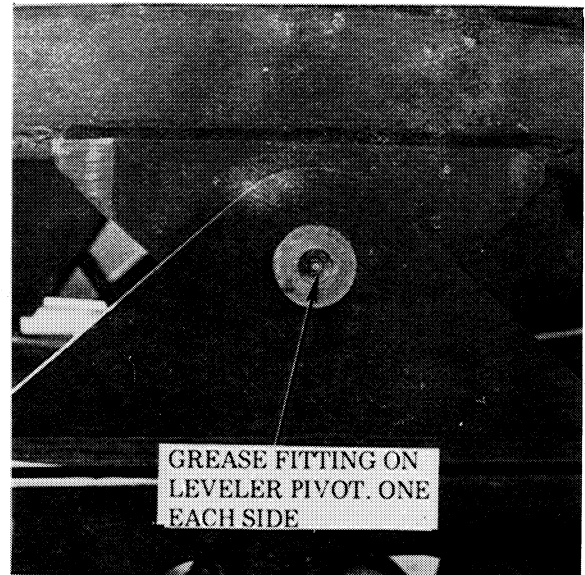

Figure 3. Location of Grease Fittings on Leveler Assembly



GREASE FITTING ON
LEVELER CYLINDER
(ONE/CYLINDER)

Figure 4



GREASE FITTING ON
LEVELER PIVOT. ONE
EACH SIDE

Figure 5

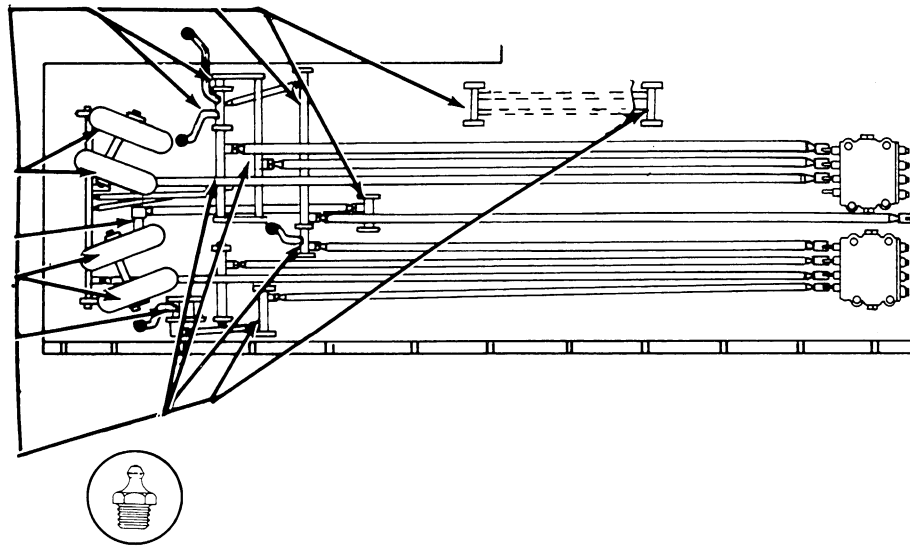

Figure 6. Location of Grease Fittings on Control Linkage and Bellcranks.

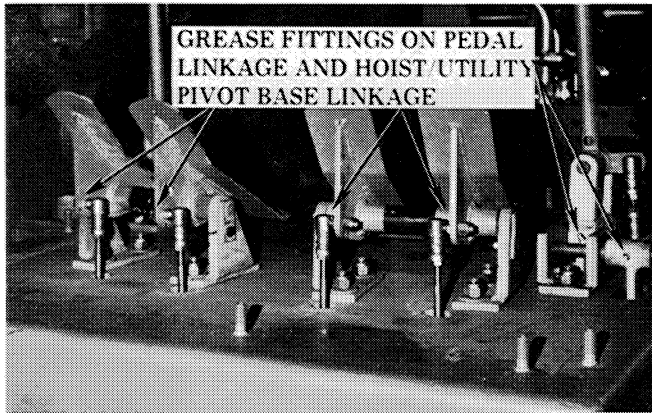

Figure 7

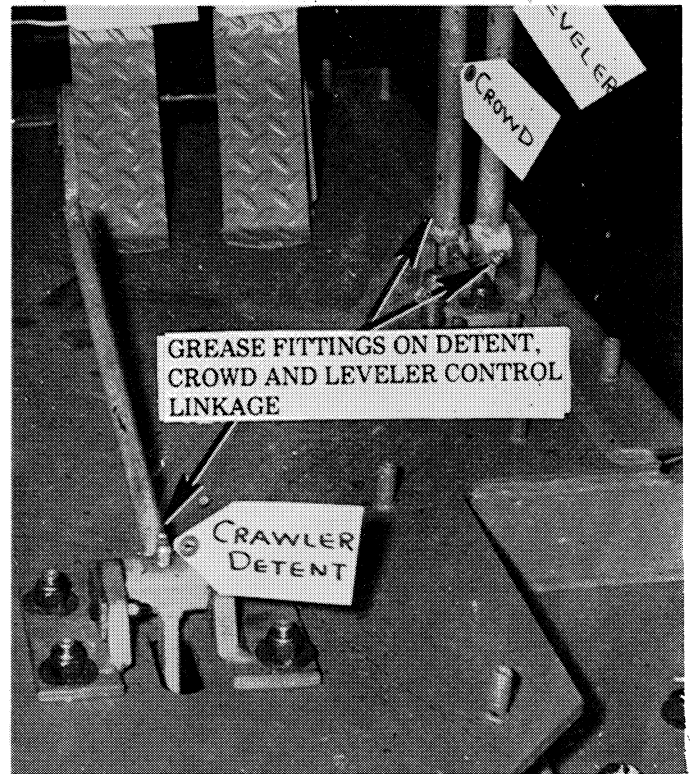

Figure 8

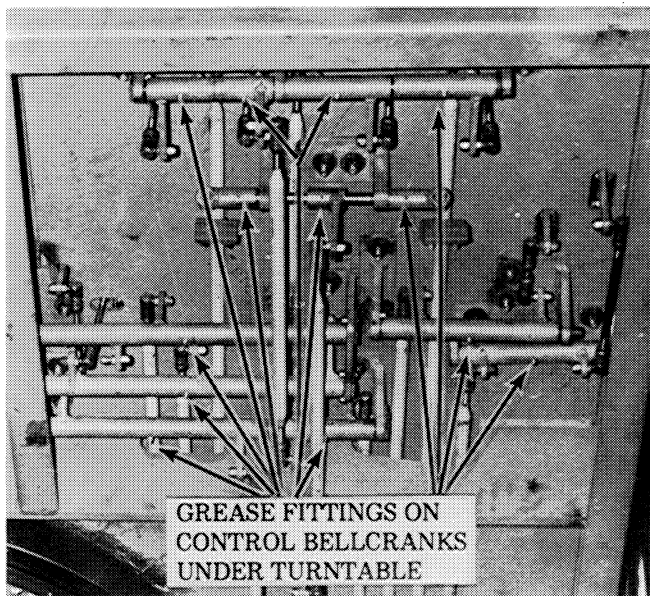

Figure 9

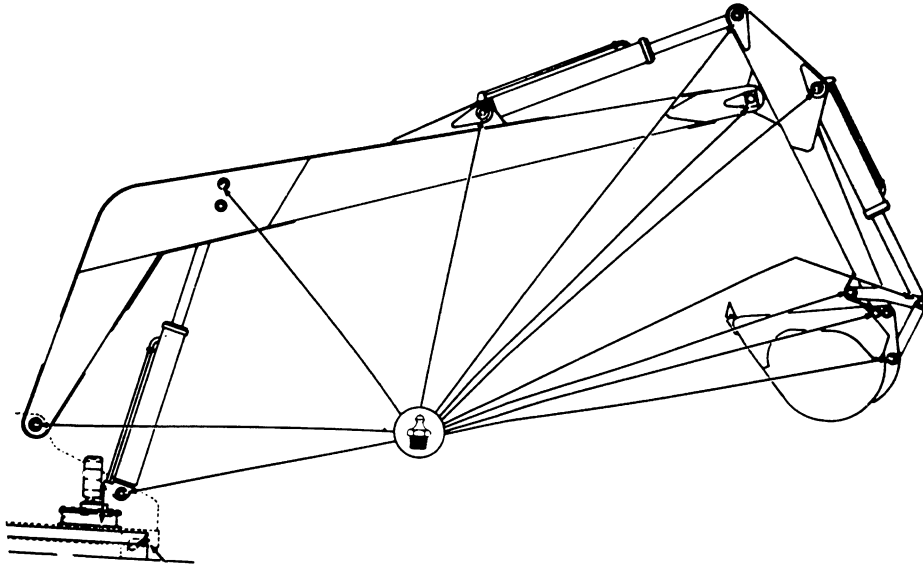

Figure 10. Location of Grease Fittings on Boom and Cylinders.

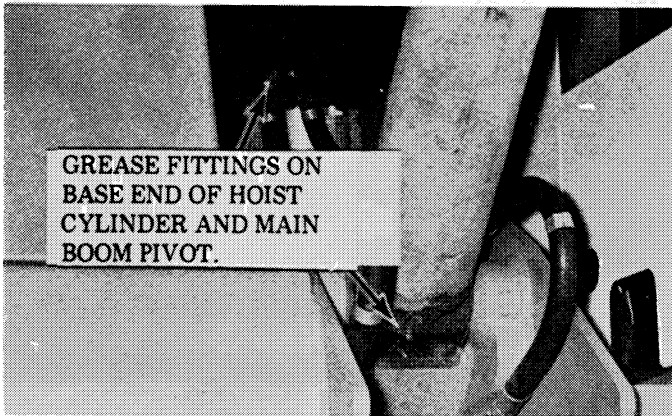

Figure 11

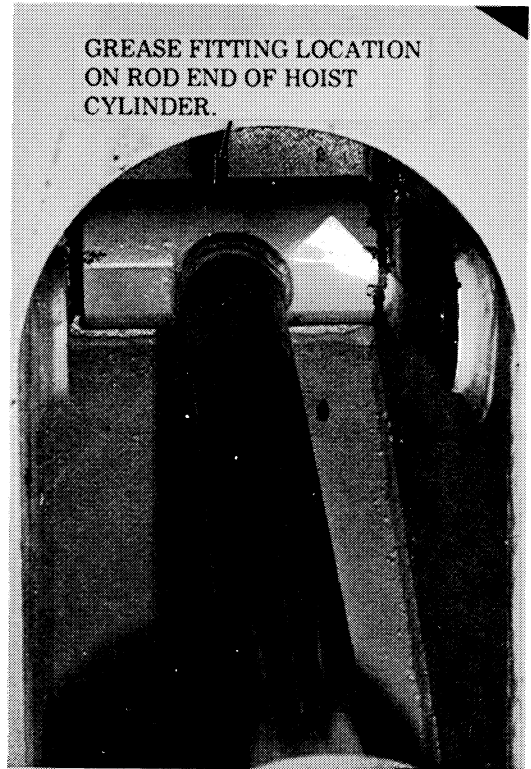

Figure 12

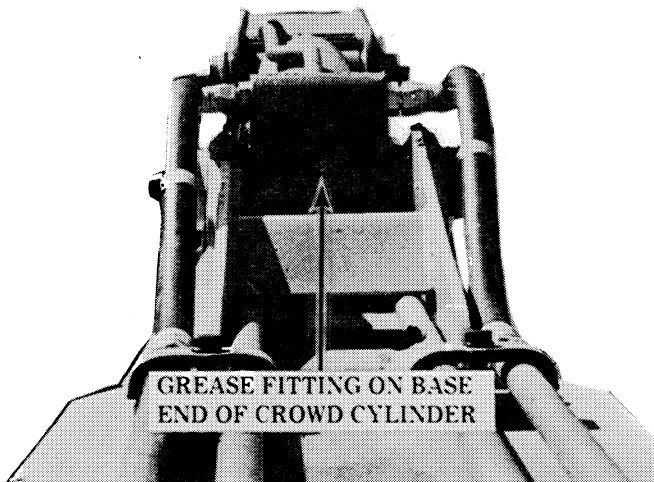

Figure 13

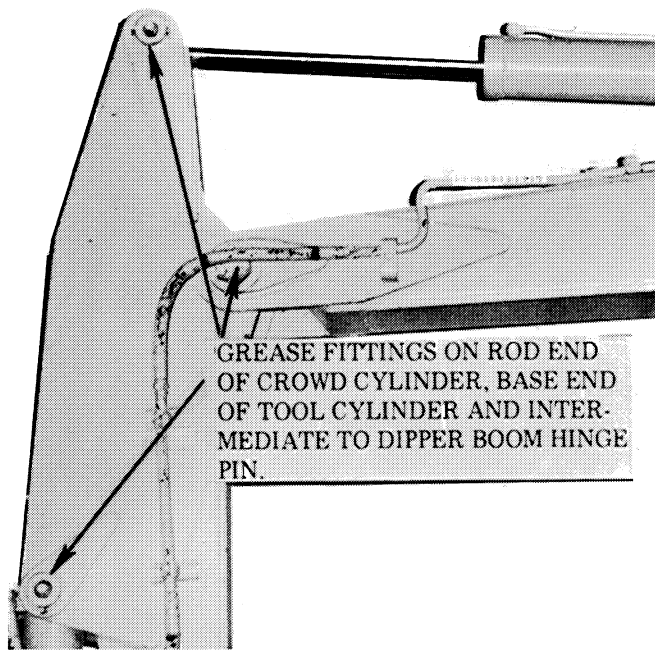

Figure 14

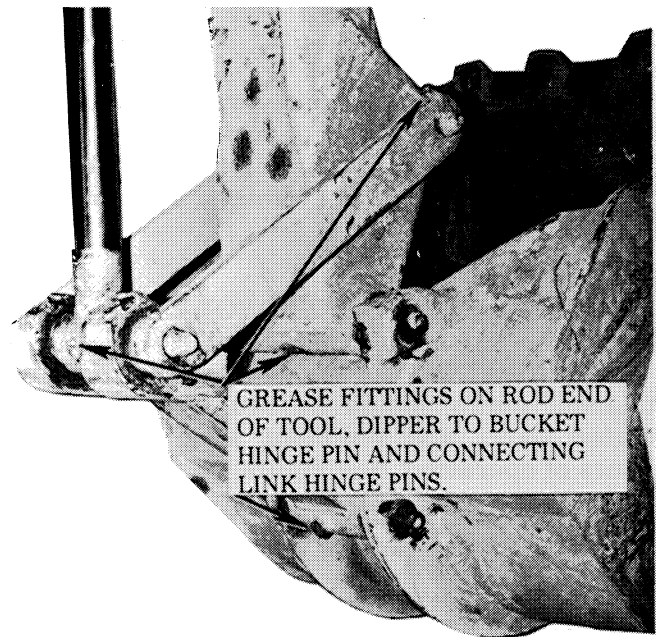

Figure 15

ENGINE OIL AND FILTERS

CHECKING ENGINE OIL LEVEL

Check the Engine oil level daily, using the dipstick on the right side of the Engine (rear of Excavator). See Figure 16. Oil level should be between the Full and Low marks on the dipstick. Do not check the oil level while the machine is running. Be sure the Excavator is level when checking the oil.

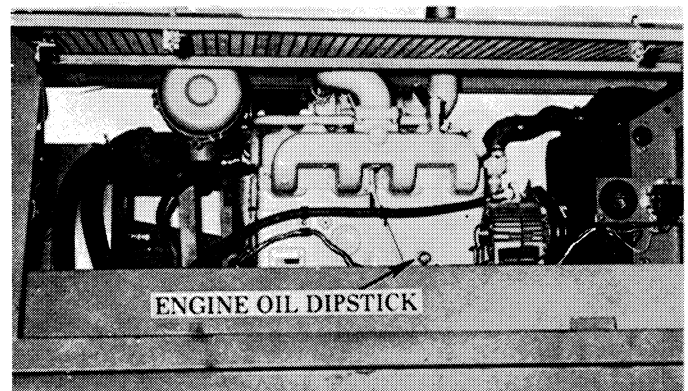

Figure 16

CHANGING ENGINE OIL

The engine oil should be changed every 100 hours of operation, or every two weeks, whichever occurs first. This is a suggested maximum; if operating conditions are severe, the oil should be changed more often.

REPLACING ENGINE OIL FILTER

The spin-on type oil filter is located on the left hand side of the engine, see Figure 17.

You cannot determine the condition of an oil filter by appearance. It may not appear excessively dirty, but it can be completely contaminated with abrasive material. Therefore, change the oil filter AT LEAST every second oil change.

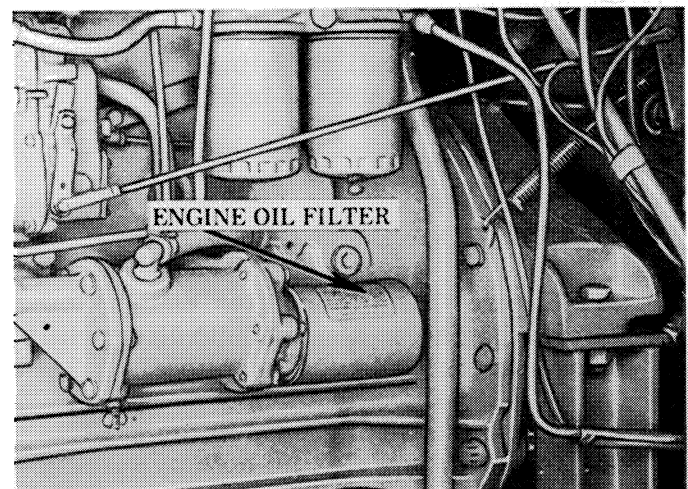

Figure 17

REPLACING FUEL FILTERS

Service the fuel filters every 500 hours, or when loss of horsepower is evident. To correct loss of power, service the filters in the following order: (1) Transfer pump (2) First and Second Stage.

TRANSFER PUMP FILTER BOWL

The filter bowl, located beneath the fuel transfer pump should be drained of accumulated water and sediment after every 300 hours of operation. See Figure 18.

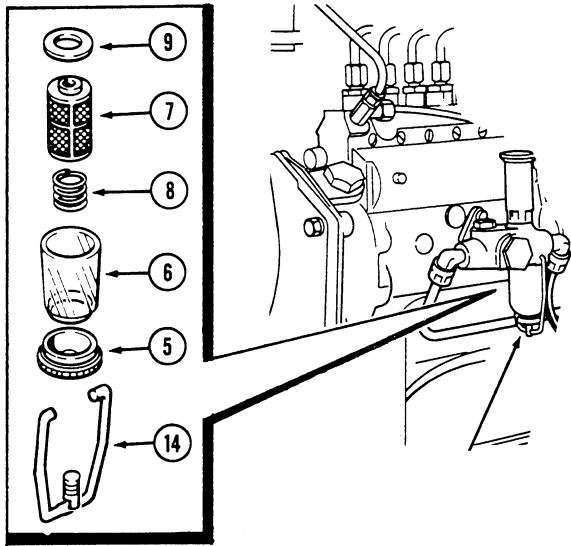

Figure 18

Loosen the bowl bail. Remove bowl with gasket, spring and screen, and clean out sediment and water. Reseat screen, spring and gasket, and replace bowl in bail. Tighten bail so that bowl is retained, but still loose. Loosen hand pump plunger on transfer pump and operate hand pump until the bowl overflows. Then tighten bail nut being careful not to overtighten and crack the bowl.

FIRST AND SECOND STAGE FILTERS

1. See Figure 19. Clean filter bodies and surrounding area. Remove both filters with a strap wrench. Discard the filters.
2. Apply a thin film of grease to the gaskets on the new filters. Install both by turning on clockwise until gasket contact is made. Hand tighten $1/2$ to $3/4$ turn. Bleed system.

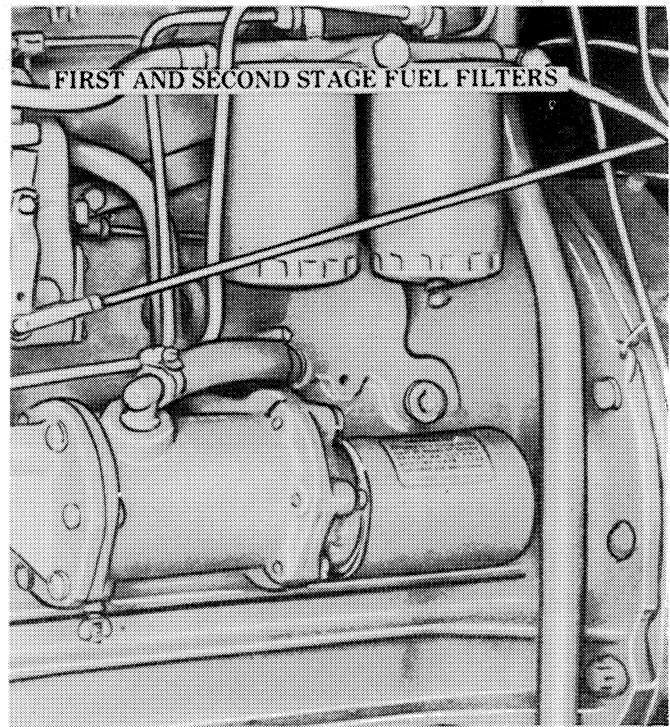

Figure 19

FIRST STAGE FUEL FILTER

If accumulated water is suspected in the first stage fuel filter, loosen the drain plug on the filter bottom. Do not remove the plug. Allow the fuel to drain until clear of water. Tighten the drain plug. See Figure 20.

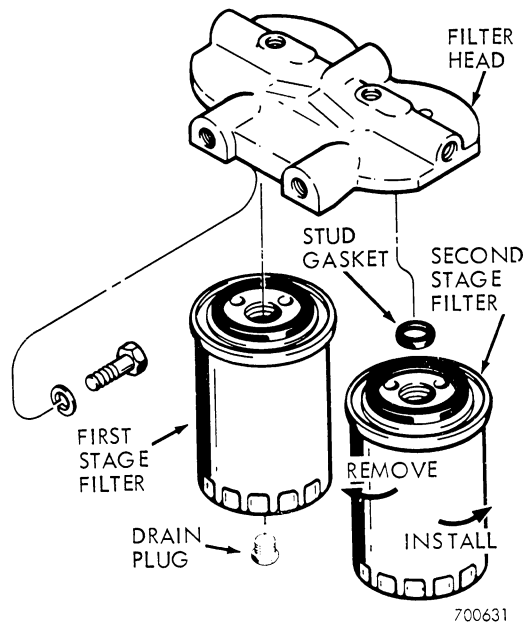

Figure 20

BLEEDING THE SYSTEM

Air must be bled from the fuel system if (1) the engine runs out of fuel, (2) the fuel system is serviced, or (3) the engine is taken out of storage.

1. Loosen the hand pump plunger on transfer pump and open bleed screw on top of the first stage filter. Operate the hand pump until clear fuel appears.
2. Bleed the second stage filter in the same manner as the first stage.
3. Start the engine. If roughness or missing is detected, bleed each injector line by "cracking" open the tube nut at the injector.

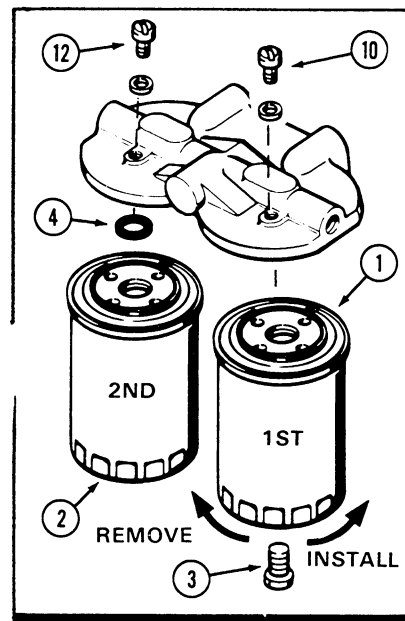

Figure 21

AIR CLEANING SYSTEM

Although filter elements are normally considered expendable, proper and careful cleaning can extend their life several times. Maintenance schedule will depend upon the dust conditions in which the engine operates. The service interval can vary from once a day to once a year. Because some engines operate constantly in a dusty environment and others operate in relatively clean air, each engine air cleaner will require servicing at different intervals. Work out a schedule that is frequent enough to avoid down-time for service on the job, but doesn't over-service. Over-service is common and can be costly.

DUST COLLECTION CUP

Empty the dust cup at regular intervals. These intervals may vary from 4 hours to 600 hours, depending on dust conditions. Do not allow the dust level in the cup to build up to closer than 1/2 inch from the slot in the dust cup baffle. Refer to Figure 22. Stop the engine. Remove the dust cup, then remove the baffle from the cup and empty the dust. Replace the baffle in the cup, making sure that the baffle is properly seated. Check the dust sealing edge for damage. Check the dust cup gasket (if so equipped). Replace the dust cup and make sure it is properly positioned on the air cleaner body. The proper cup position is indicated by the arrows located on the bottom of the cup. Also, the slot in the dust cup baffle must be at the top.

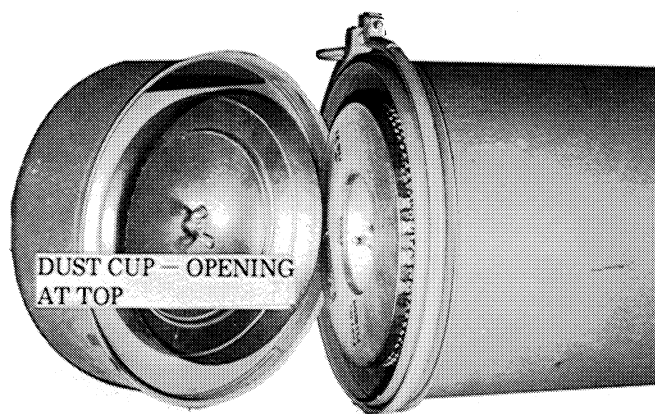

Figure 22

MAIN ELEMENT

Excessive smoke or loss of power are good indications that the main element should be cleaned or replaced. Check the restriction indicator mounted between the engine and the air cleaner for a correct analysis of the condition of the main element. Try to clean the element before the indicator reaches the red portion of the gauge.

NOTE: In the event you feel the restriction indicator is malfunctioning, remove it and place a water manometer tube in its place. Start the engine and check the amount of restriction on the manometer. The main element should be cleaned or replaced when restriction reaches 15 inches of water.

If you used a manometer, as in the above Note, be sure to replace the restriction indicator or put a plug in the restriction tap. This will prevent the entry of dirt or foreign material into the system.

Standby filter elements, either new or cleaned, will speed servicing and reduce down-time.

CAUTION: Do not over-service. Over-servicing increases the chances of damage to the filter element and getting dust into the engine.

CAUTION: Do not start the engine when the filter element is removed from the air cleaner. While cleaning element, place a warning tag on the air cleaner and another tag on the starting switch.

WASHING THE ELEMENT

Washing is the preferred method of cleaning the element because it removes more dust and soot and restores the element to an almost new condition. This will result in better engine performance and longer intervals between service. It is handy to have a spare element available for use while the serviced element is drying. This will reduce down-time to only a few minutes and allow sufficient time to properly service the restricted element.

To wash the filter element, use Case Filter Element Cleaner, Part No. A40910, which is available from your Authorized Case Dealer. Mix 2 ounces of cleaner to one gallon of water (temperature 70° to 100° F.). Soak the element in this solution for 15 minutes; see Figure 24. Rinse thoroughly. Do not use water pressure over 40 PSI at the nozzle. Let the element air-dry completely before installing. Do not use air pressure to dry the element.



Figure 24 - Soaking the Element

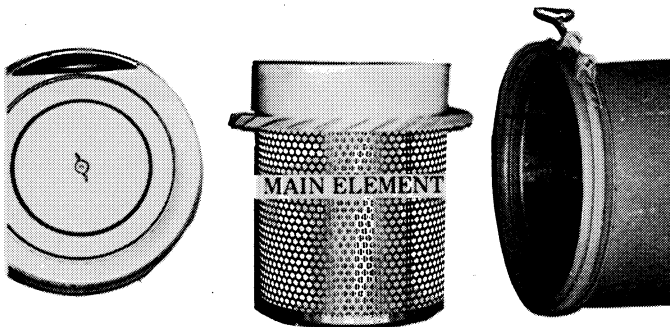

Figure 23

COMPRESSED AIR CLEANING

The element can also be cleaned with compressed air, using a maximum 100 PSI pressure at the nozzle. Keep the air nozzle a reasonable distance from the filter element. Use of compressed air is not always recommended because it will not remove carbon and soot like washing does.

The filter element must also be checked for dents in the metal covering. Any dent in the covering is a potential puncture because it lets the paper element rub the dent putting a hole in the paper. If any fuzz is noted around a dent or any place in the element, the element is punctured. Replace it immediately or serious damage will result. Do not accept a new filter or install a new or used filter if the metal covering is dented.

CAUTION: Never attempt to clean the element by rapping it. Rapping the element will dent the metal covering. The inner paper element will in turn rub this dent, causing the element to puncture.

INSPECTING ELEMENT

To inspect the element after it is clean and dry, use a light bulb. By rotating the filter element against the light, the element can be checked for damage or pinholes. Visually check the rubber gasket for damage. If any holes appear in the element or the gasket is damaged, the element must be replaced.

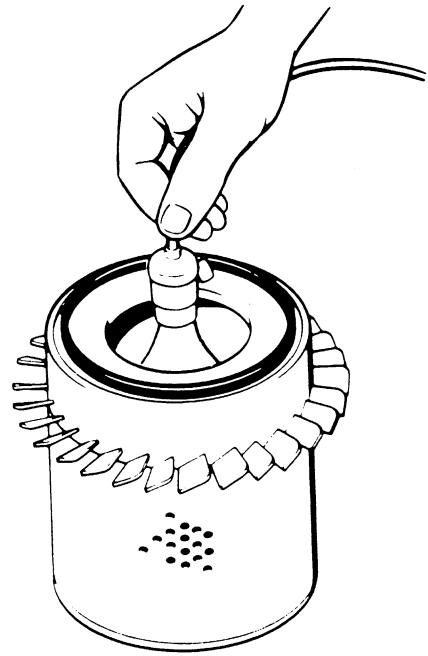

Figure 25 - Inspecting the Element

COOLING SYSTEM

RADIATOR CAP

Coolant capacity9.5 US gallons
 Radiator cap pressure.....7 PSI
 Thermostat range
 starts to open at 175°-182° F., fully open at 202° F.
 Standard factory coolant installation.....
50% water, 50% antifreeze

The radiator pressure cap serves two purposes:

1. It pressurizes the cooling system at 7 PSI, thereby raising the boiling point of the coolant, and reduces loss of coolant by evaporation, surging and boiling. The efficiency of a pressurized system is maintained by immediate repair of leaks and replacement of weak or defective parts.
2. It serves as a relief valve if system pressure rises above 7 PSI.

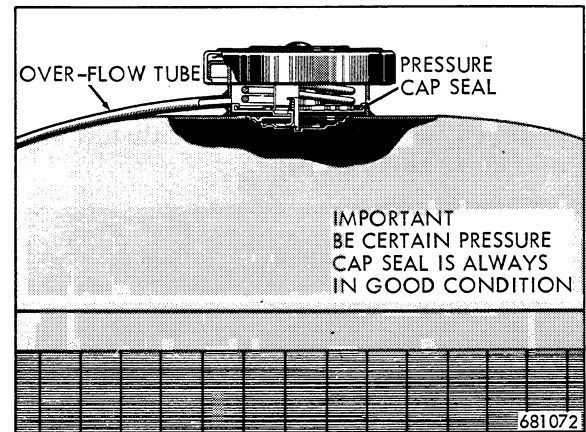

Figure 26 - Radiator Pressure Cap

WARNING: Always remove the pressure cap slowly. Quick removal of the cap can reduce system pressure enough to make the coolant boil out of the radiator opening and result in painful burns to the operator.

ANTIFREEZE

Use only a reputable brand of permanent type, high boiling point, ethylene glycol antifreeze.

The crawler is shipped from the factory with a 50% solution of permanent type (ethylene glycol) antifreeze, and 50% water. The antifreeze should never be used for more than one winter due to the natural breakdown of rust inhibitors.

Do not mix different types or brands of antifreeze in the cooling system. They may not be chemically compatible, and the mixtures will not give correct test readings.

NOTE: The use of low boiling point, alcohol type antifreeze is not recommended. Evaporation loss would be excessive because the alcohol boiling point is frequently below the crawler minimum operating temperature.

CLEANING THE SYSTEM

Clean the cooling system at least twice a year or every 1000 hours of operation. Clean oftener in areas where hard water containing scale forming materials is all that is available.

To clean the cooling system:

1. While the coolant is still hot, open the radiator drain valve and the engine block drain valve. See Figure 27. Drain all coolant and close the valves.

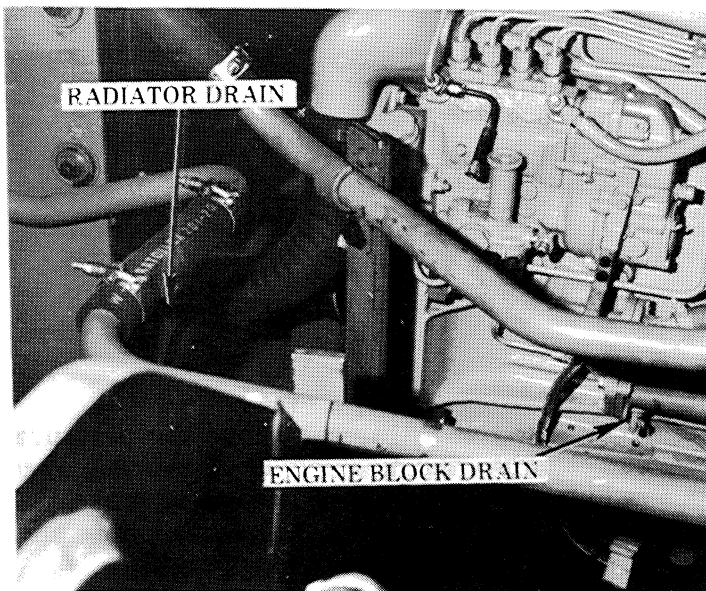

Figure 27

2. Add a radiator cleaner to the system and refill with clean water. Any nationally known commercial brand cleaner marketed by a reputable manufacturer may be used. Follow the directions provided with the cleaner.
3. After draining the cleaning solutions, flush the system with clean water before refilling the radiator.
4. Check the hoses, elbows, pump and water manifold for leakage.
5. Make sure the outside of the engine is clean and that the radiator fins are free of dirt accumulations. Blow dirt and trash out of the radiator with compressed air.
6. Refill the cooling system to within 2 inches of the top of the radiator neck.
7. Run the engine approximately 5 minutes to bleed the air out of the system. Recheck the coolant level and add coolant, if necessary.

WATER COOLANT

If water alone is used in the cooling system during the summer months, add a rust inhibitor.

If possible, use soft water. If only hard water is available, check the system at frequent intervals for signs of scale formation.

CAUTION: Never pour coolant into a hot engine. The engine block or cylinder heads could crack because of sudden contraction caused by temperature differences between the metal and the coolant.

Never remove the radiator cap when the engine temperature gauge shows the engine is overheated. Coolant may boil away allowing engine parts to cool too fast and causing the block or heads to crack.

THERMOSTAT

TEMPERATURE RANGE

The cooling system is equipped with a thermostat that starts to open at 175°-182° F., and is fully open at 202° F., and remains open above 202° F. Coolant temperature will vary according to the excavator workload. If the radiator is equipped with a properly functioning 7 PSI pressure cap, the excavator can operate with engine coolant temperatures up to 230° F. without damage to the engine or loss of coolant.

CHECKING THERMOSTATS

During operation, check the engine temperature gauge frequently. Should the engine warm up very slowly under load, or if the engine temperature gauge needle does not reach the recommended operating range, remove and check the thermostat. This can be done by suspending the thermostat in a pan of water that is being heated and checking the opening temperature with a thermomoter.

If a thermostat is inoperative, discard it and install a Genuine Case thermostat having the same heat range as the original. The thermostat must start to open at 175°-182° F. and be fully open at 202° F.

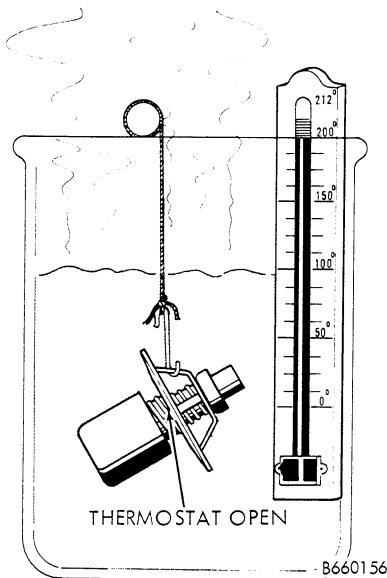

Figure 28 - Checking Thermostat

An engine that is not working under a load may be slow to warm up to operating temperature. This is normal and is due to the large capacity of the cooling system. However, when the engine is under load, it should warm up reasonably soon.

REPLACING THERMOSTAT

To replace the thermostat:

1. Partially drain the cooling system to below the level of the thermostat and raise the access cover on top of the hood.
2. Remove the two thermostat housing bolts and lockwashers, and loosen hose clamps on the upper hose.
3. Remove all the old gasket material.
4. Install new thermostat.
5. Install a new gasket on water manifold. Place a thin film of sealing compound on both sides of the gasket.
6. Reinstall housing, housing bolts and hose clamps.
7. Close coolant drain valves. Refill cooling system. Operate engine for about five minutes and check for leaks. Check coolant level and add coolant if necessary.

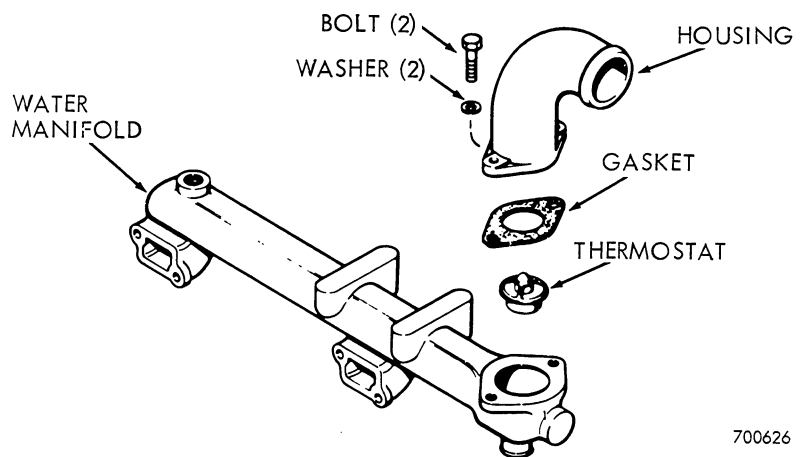

Figure 29 - Installing Thermostat

FAN

A pusher type fan is standard equipment. A suction type fan is available as optional equipment from your Authorized Case Dealer.

If necessary to replace the fan, always order a Genuine Case fan intended for the engine so that the cooling system will operate at top capacity.

FAN BELTS

Check the engine fan belts weekly or every 50 hours. The belts drive the fan, water pump and alternator. If too tight, there is rapid wear of alternator and water pump bearings. If too loose, the belts will slip, wear fast, and permit engine overheating and battery run-down.

BELT TENSION

Properly adjusted vee belts can be depressed 1/2 inch midway between the alternator pulley and then fan pulley. To tighten belts, loosen alternator mounting bolt at adjusting strap, and swing alternator away from machine.

CAUTION: The fan belts must ride on the sides of the pulley — never on the bottom.

The fan belts are a matched set. Do not replace the belts individually. Always use a matched set.

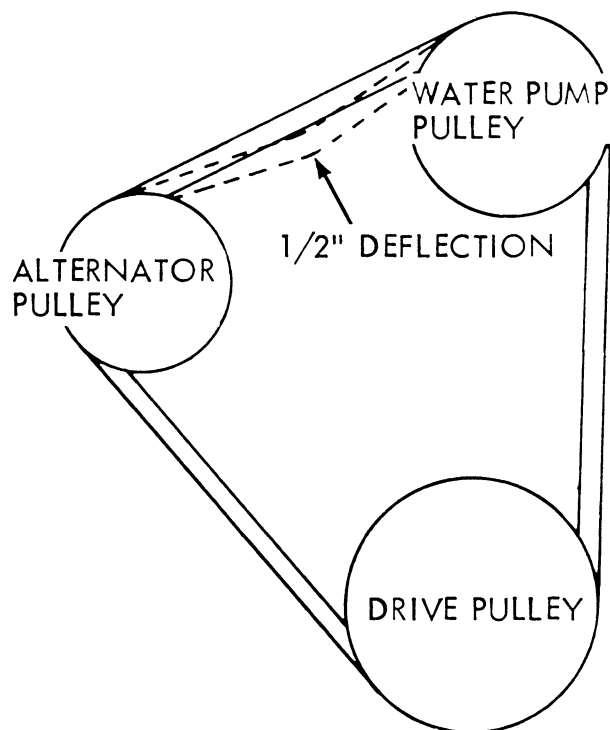

Figure 30 - Adjusting Fan Belts

700721

TURBOCHARGER

The turbocharger, which is standard equipment on the 880 Excavator, is an economical method of boosting engine power, but it is critically dependent on:

1. Clean and sufficient air intake.
2. Clean and adequate engine oil.

It is mandatory that regular maintenance and careful checking be done on the air cleaner system and the engine oil filtering system.

AIR CLEANING

The high speed turbine and compressor of the turbocharger are highly vulnerable to foreign particles in the air intake and exhaust. To avoid such damage:

1. Follow closely the maintenance schedule for the air cleaning system.
 - a. Keep filter and dust cup free and unclogged.
 - b. Replace damaged or defective filters immediately.
2. Inspect air intake lines and connections for leaks which let foreign particles bypass the air cleaning system.

LUBRICATION

ENGINE OIL

Engine oil acts as a lubricant and a coolant for the turbocharger bearings, and as a heat barrier between the hot turbine and compressor. Dirty oil leads to turbocharger overheating failure, and possible damage to the engine itself. To avoid such damage:

1. Change engine oil on a regular schedule, and as often as necessary to keep it clean.
2. Change the oil filter on a regular basis, or as often as necessary to keep it and the oil clean.

OIL FAILURE

In addition to dirty oil, which signals poor maintenance, the following can cause turbocharger damage or failure:

1. OIL LAG - This problem occurs:
 - a. During cold weather starting, when engine oil is too stiff to flow quickly to turbocharger bearings.
 - b. After oil and filter changes, when the lubrication system needs some priming.
 - c. While starting under load, before the oil is warm enough to adequately lubricate load-bearing components.

Do not rev up the engine immediately after a cold start. Warm up the engine for about five minutes at 1/4 throttle and no-load. Engine oil will have a chance to warm up and adequately lubricate turbocharger bearings before load conditions are imposed on them.

If the excavator has been in storage for a month or more, the turbocharger lubrication system should be primed by cranking the engine for about 30 seconds with the fuel supply shut off.

2. OIL STARVATION - Dirty oil leads to worn bearings, oil pump failure, plugged oil lines and clogged filters. These problems in turn cause oil starvation to critical turbocharger components which are damaged by loss of oil pressure and overheating. Clean engine oil and adequate filtration will prevent oil starvation.

STOPPING

If the engine has been under heavy, severe load and is shut off without several minutes of idling for cooling purposes, the turbocharger will keep rotating at high speed without lubrication or cooling. Reduce engine speed to 1/2 throttle for about 5 minutes to lubricate and cool the turbocharger while it is decelerating.

If the excavator is kept outdoors overnight, cover the exhaust stack to keep moisture out of the turbocharger bearings. The stack should also be covered when moving the excavator on a low-boy trailer or on any other method of transporting.

HYDRAULIC SYSTEM

HYDRAULIC RESERVOIR OIL LEVEL

The oil level in the hydraulic reservoir should be checked daily or every 10 hours, whichever occurs first.

The oil level can be checked by removing the filler cap and checking level on the dipstick. Clean thoroughly around the filler opening before removing the cap. Oil should be at the level of the FULL mark. Figure 31 shows location of fill cap on reservoir.

Before checking oil level, completely extend the bucket and dipper cylinders, and retract the boom cylinder. The turntable should be level and the machine parked on a level surface.

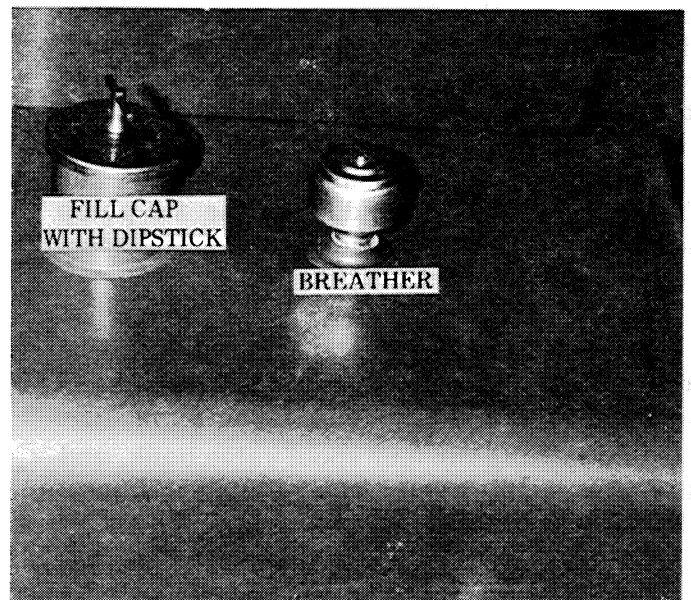

Figure 31

CHANGING HYDRAULIC OIL

The hydraulic oil should be changed every 1500 hours, or semi-annually, whichever occurs first. Unless there is evidence of oil contamination, a reservoir drain and refill is sufficient. After the crawler's first 20 hours of operation during the run-in period, change the oil and the oil filters.

The oil should be drained while at operating temperature. At the same time, the 100 Mesh Screen in the reservoir outlet should be removed and cleaned in a non-flammable solvent.

Refill the reservoir with clean Case TCH Fluid in the amounts specified under Refill on page 3 .

HYDRAULIC RESERVOIR BREATHER

The reservoir breather should be serviced whenever the hydraulic oil is changed, every 1500 hours or twice yearly.

The breather is located on top of the tank, encased in a red housing. Remove the breather and wash the element in a non-flammable solvent. Blow dry with compressed air. Refer to Figure 31.

HYDRAULIC FILTERS (IN-LINE AND IN-TANK)

There are three hydraulic filters incorporated into the 880's hydraulic oil system. Two of the filters are rated at 100 Mesh Screen, and the third is a 33 Micron element. One of the 100 Mesh Screen filters is located in the outlet port of the Hydraulic tank, see Figure 32; the other will be found in the output line from the oil cooler leading to the #1 pump section (the section feeding the three spool valve bank). Refer to Figure 33.

The 33 Micron Filter will be found in the return line from the three spool valve bank leading to the #2 section of the pump (the section feeding the four spool valve bank, and the one spool leveler control valve. Figure 33 gives location.

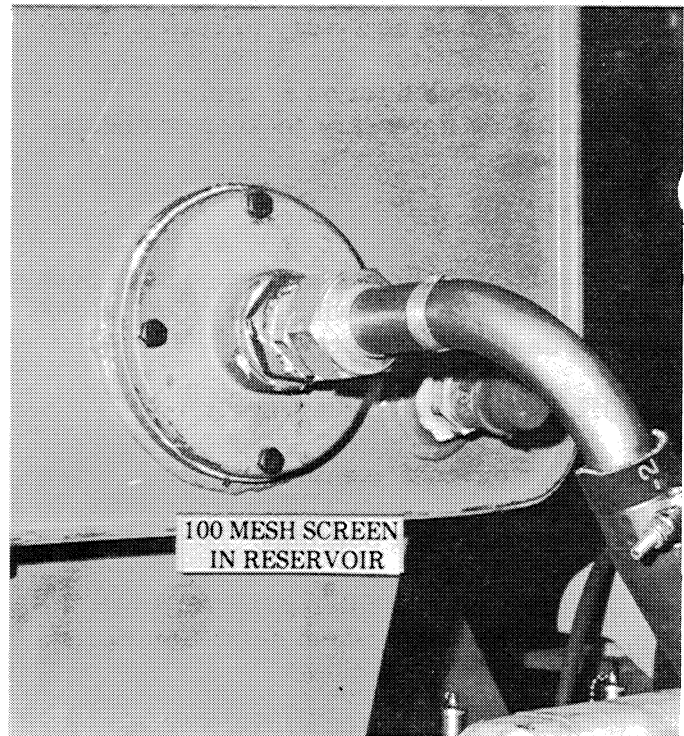

Figure 32

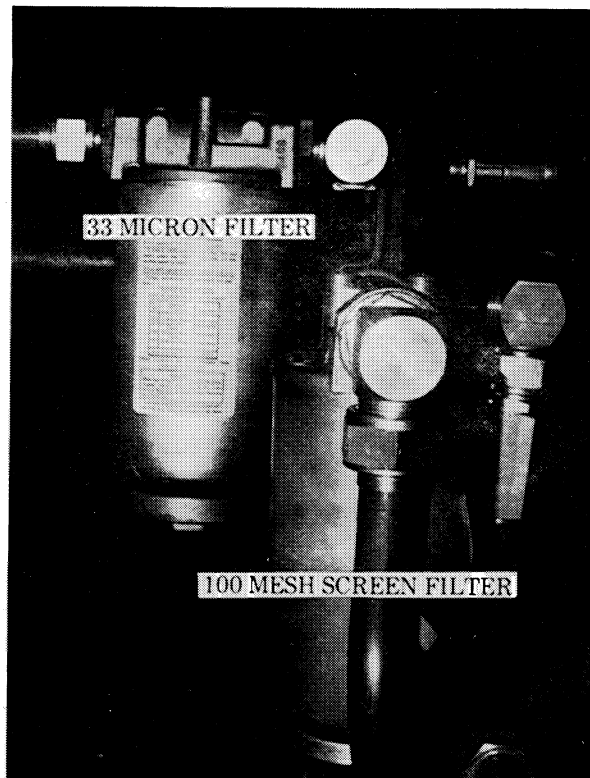

Figure 33

The 33 Micron Filter Element should be removed and changed; and the 100 Mesh Screens should be removed and cleaned every 500 hours, or two months, whichever occurs first. Clean the Mesh Screens in a non-flammable solvent. Obtain a replacement element for the 33 Micron Filter from your Authorized Case Dealer.

Use the following procedure:

1. Clean the entire outside of the filter housing.
2. Unscrew and drop the center post.
3. Remove filter housing, back-up washer, gasket and filter element.
4. Discard old element and seals. CLEAN ALL PARTS and filter housing in a suitable non-flammable solvent. Dry them thoroughly with compressed air.
5. Obtain a new filter element and seals. Reassemble as shown in Figure 34.

NOTE: When reassembling, be sure the center post has a gasket seal. Gasket, bottom of housing, and flange of center post must be free of oil and grease when center post is tightened to prevent extrusion of gasket.

6. Torque center post to no more than 12 ft. lbs.

NOTE: The by-pass valve at the top of the filter allows dirty oil, cold oil, or oil at excess pressure to pass by the filter, thus preventing damage to the filter element.

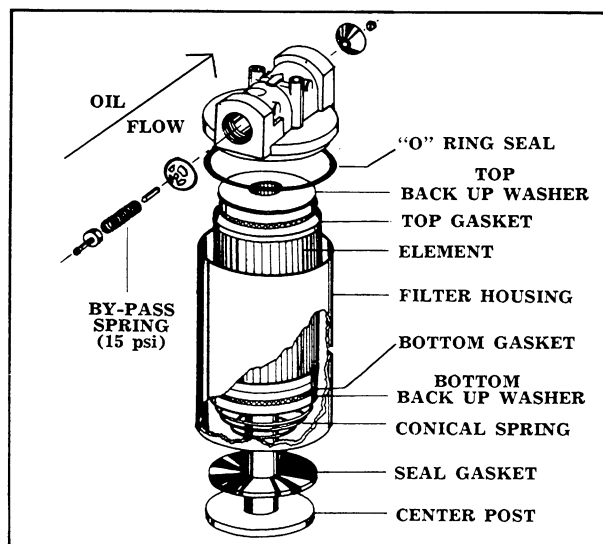

Figure 34

MECHANICAL COMPONENT MAINTENANCE

SWING REDUCTION GEARBOX

Oil level should be checked weekly or every 50 hours, whichever occurs first. Oil should be changed every 1500 hours, or semi-annually, whichever occurs first. Check, drain and fill plugs are indicated in Figure 35. Use SAE 90, API-GL4 all seasons.

FINAL DRIVE TRANSMISSIONS

Check level of oil weekly or every 50 hours, whichever occurs first. Drain oil and refill semi-annually or every 1500 hours, whichever occurs first. Check, fill and drain locations are indicated in Figure 36. Use SAE 90, API-GL4 all seasons.

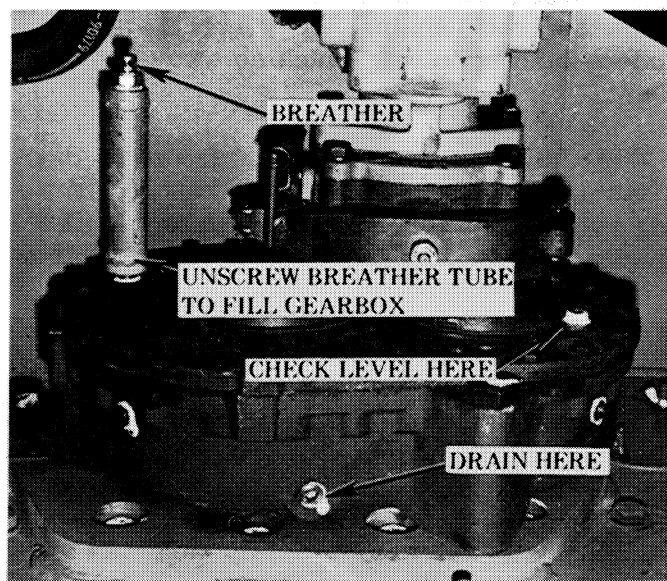

Figure 35

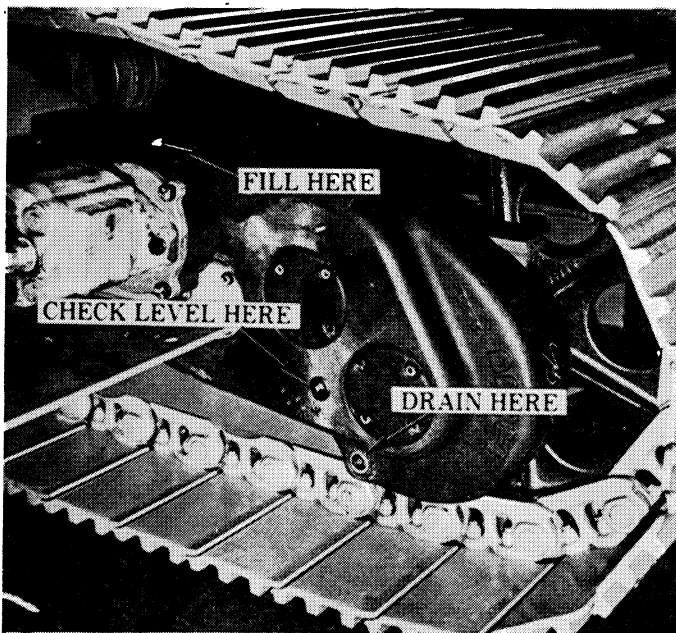

Figure 36

CRAWLER DRIVE BRAKES (AUTOMATIC)

Check adjustment on brakes monthly or every 250 hours, whichever occurs first. Refer to section 71 for adjustment procedure.

TRACK AND ROLLER MAINTENANCE

Clean tracks and rollers, especially during cold weather. Don't allow the tracks to freeze to the ground. Drive the crawler up on planks or timbers and cover with a tarpaulin for the night. Wet mud and slush should be cleaned from the track chains, track sprockets and rollers before putting machine away for the night.

In the event the tracks do freeze to the ground, do not try to break the crust by driving away. Use a pinch bar or torch to free the tracks.

Check tension on tracks daily, and adjust for your specific operating conditions. Operating conditions are the biggest factor in relation to proper track chain tension. A track that is properly adjusted for running on hard packed material will be too tight while operating in very sticky mud, wet snow, sanitary landfills, etc. A chain properly adjusted for the sticky mud type conditions will be too loose for operating on hard packed material.

Loose track chains tend to climb sprocket teeth and will jump under heavy pulls. Track chains that are kept too tight will cause undue wear on pins, bushings and front idler bearings. Refer to Section 58 for adjustment procedure on track tension.

TURNTABLE OPEN GEAR

Lubricate daily or every 8 to 10 hours, depending on severity of use. Use a spray-on open gear lubricant such as Mobil Mobiltac - E, Sohio Sohitac # 1, Sunoco 407 Compound B, Texaco Crater Compound or functional equivalent.

Procedure: Remove the access hole cover in the turntable deck (Figure 37 shows location), and spray lubricant at the gear teeth while turntable is rotated slowly through several revolutions.

NOTE: Never place your hand inside the access hole while the turntable is moving. If you find it necessary to place hand inside opening, stop the turntable and set the swing brake.

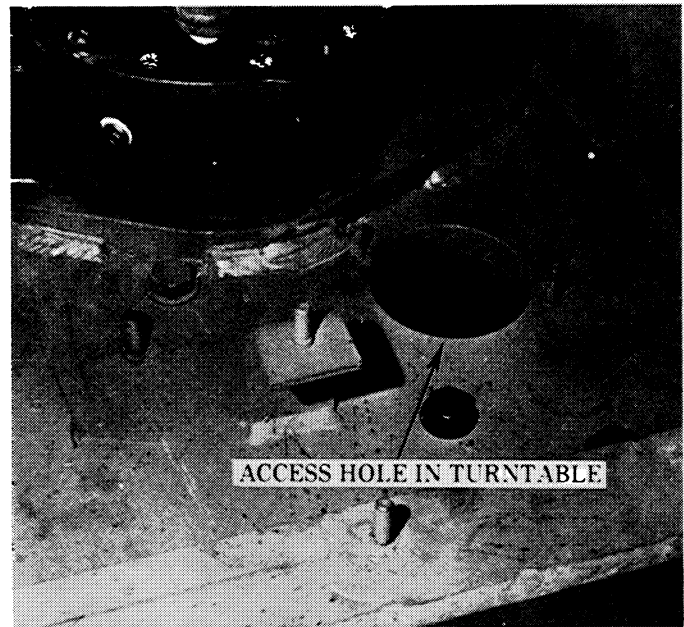

Figure 37

Section

1023

SPECIFICATION DETAILS

336BD ENGINES

Written In *Clear
And
Simple
English*

FRACTION to DECIMAL to MILLIMETER CONVERSION TABLE

Fraction	Decimal	MM	Fraction	Decimal	MM	Fraction	Decimal	MM
1/64	.0156	0.397	23/64	.3593	9.128	45/64	.7031	17.859
1/32	.0312	0.794	3/8	.3750	9.525	23/32	.7187	18.256
3/64	.0468	1.191	25/64	.3906	9.922	47/64	.7343	18.653
1/16	.0625	1.587	13/32	.4062	10.319	3/4	.7500	19.050
5/64	.0781	1.984	27/64	.4218	10.716	49/64	.7656	19.447
3/32	.0937	2.381	7/16	.4375	11.113	25/32	.7812	19.844
7/64	.1093	2.778	29/64	.4531	11.509	51/64	.7968	20.240
1/8	.1250	3.175	15/32	.4687	11.906	13/16	.8125	20.637
9/64	.1406	3.572	31/64	.4843	12.303	53/64	.8281	21.034
5/32	.1562	3.969	1/2	.5000	12.700	27/32	.8437	21.431
11/64	.1718	4.366	33/64	.5156	13.097	55/64	.8593	21.828
3/16	.1875	4.762	17/32	.5312	13.494	7/8	.8750	22.225
13/64	.2031	5.159	35/64	.5468	13.890	57/64	.8906	22.622
7/32	.2187	5.556	9/16	.5625	14.287	29/32	.9062	23.019
15/64	.2343	5.953	37/64	.5781	14.684	59/64	.9218	23.415
1/4	.2500	6.350	19/32	.5937	15.081	15/16	.9375	23.812
17/64	.2656	6.747	39/64	.6093	15.478	61/64	.9531	24.209
9/32	.2812	7.144	5/8	.6250	15.875	31/32	.9687	24.606
19/64	.2968	7.541	41/64	.6406	16.272	63/64	.9843	25.003
5/16	.3125	7.937	21/32	.6562	16.669	1	1.0000	25.400
21/64	.3281	8.334	43/64	.6718	17.065			
11/32	.3437	8.731	11/16	.6875	17.462			

INCH to MILLIMETER CONVERSION TABLE

Inch	MM	Inch	MM	Inch	MM	Inch	MM
1	25.400	6	152.000	10	254.000	60	1,524.000
2	50.800	7	177.800	20	508.000	70	1,778.000
3	76.200	8	203.200	30	762.000	80	2,032.000
4	101.600	9	228.600	40	1,016.000	90	2,286.000
5	127.000	10	254.000	50	1,270.000	100	2,540.000

TABLE OF CONTENTS

RUN-IN INSTRUCTIONS	4
ENGINE SPECIFICATION DETAILS	
Cylinder Sleeves	5
Piston with 1.62" (41.15 mm) Pin Bore	5
Piston with 1.80" (45.72 mm) Pin Bore	5
Piston Pin for Piston with 1.62" (41.15 mm) Pin Bore	5
Piston Pin for Piston with 1.80" (45.72 mm) Pin Bore	5
Piston Rings	6
Connecting Rod for Piston with 1.62" (41.15 mm) Pin Bore	6
Connecting Rod for Piston with 1.80" (45.72 mm) Pin Bore	6
Crankshaft with 3" (76.2 mm) Main Bearing Journals	7
Crankshaft with 3.5" (88.9 mm) Main Bearing Journals	7,8
Camshaft	8
Valve Push Rod Lifters	8
Gear Train	9
Oil Pump and Two Gear Balancer	9
Oil Pump and Three Gear Balancer	9
Oil Pump, Front Mounted	10
Cylinder Head	10
Exhaust Valve	10
Intake Valve	10
Intake and Exhaust Valve Guides	11
Valve Spring	11
Rocker Arm Assembly	11
Intake Valve Timing	11
SPECIAL TORQUES	12,13
GENERAL TORQUES SPECIFICATION TABLE	14

RUN-IN INSTRUCTIONS

Engine Lubrication

Fill the engine crankcase with CASE HDM oil and install new engine oil filters, after an engine has been rebuilt.

NOTE: Use a *SERIES 3 DS* or *CD SERVICE CLASSIFICATION* oil that has the correct viscosity rating for ambient air temperature, if CASE HDM oil is not used.

Change the engine oil while the engine is hot and replace the engine oil filters, after the first 20 hours of operation.

Change the engine oil and filters at the given intervals, after the 20 hours, as found in the Operator's Manual.

Run-In Procedure For Rebuilt Engines (With A Dynamometer)

The following procedure must be followed when using a PTO dynamometer to run-in the engine. The dynamometer will make sure of the control of the engine load at each speed and will remove stress on new parts during run-in.

During the run-in, continue to check the oil pressure, coolant level and coolant temperature.

STEP	TIME	ENGINE SPEED	DYNAMOMETER SCALE LOAD*
1	**10 Minutes	1000 RPM	Not Any
2	**10 Minutes	1800 RPM	Not Any
3	20 Minutes	1800 RPM	1/3
4	20 Minutes	1800 RPM	1/2
5	***30 Minutes	100 RPM below rated speed	3/4
6	Tighten the cylinder head bolts to the torque that is found in Section 2015 of the service manual.		

* According to normal dynamometer scale load at rated speed for the specific vehicle model. Decrease this scale load as shown.

** The best run-in procedure will constantly change the throttle between 750 to 1000 RPM, for the first 10 minutes and from 1000 to 1800 RPM, for the next 10 minutes. The purpose of this changing RPM is to change the lubrication and coolant flow.

*** 30 minutes at 3/4 load is a minimum amount of time the engine can be run. It is best that when possible, the engine (especially a turbocharged diesel) must be run for four (4) hours or more, at the above speed and load before checking the full engine horsepower or before using the engine for heavy field work.

Run-In Procedure For Rebuilt Engines (Without A Dynamometer)

STEP	TIME	ENGINE SPEED	LOAD
1	*10 Minutes	1000 RPM	Not Any
2	*10 Minutes	1800 RPM	Not Any
3	30 Minutes	2/3 Rated RPM	Light Load
4	1 Hour	Full RPM (not over 2000 RPM)	80 to 90%
5	Tighten the cylinder head bolts to the torque that is found in Section 2015 of the service manual.		

* If engine must then run at or near full load to operate the machine, remove the load for the first hour and run at high idle for several minutes at 15 minute intervals.

Run-In Procedure

Keep in one gear lower than normal for the first 8 hours of field operation. DO NOT "lug" the engine for the next 12 hours. Prevent "lugging" by moving the shift lever to a lower gear. The engine must not be "lugged" below the Rated Engine RPM during the early hours of life.



Suggest:

If the above button click is invalid.

Please download this document

first, and then click the above link

to download the complete manual.

Thank you so much for reading

DETAILED ENGINE SPECIFICATIONS

Cylinder Sleeves

	U.S. Value	Metric Value
Type	Wet, Can Be Replaced	
Material	Cast Iron	
ID of Sleeve	4.6250 to 4.6263"	117.475 to 117.508 mm
Maximum Service Limit	4.6283"	117.559 mm
Sleeve Out of Round (Installed in Block)	0.002"	0.0508 mm
Maximum Service Limit	0.002"	0.0508 mm
Taper (Installed in Block)	0.001"	0.0254 mm
Maximum Service Limit	0.002"	0.0508 mm
Clearance at Bottom of Piston, 90 Degree to Piston Pin ..	0.0052 to 0.0075"	0.1321 to 0.1905 mm
Maximum Service Limit	0.010"	0.254 mm

Piston with 1.62" (41.15 mm) Pin Bore

Type	Cam Ground	
Material	Aluminum Alloy	
OD at Bottom, 90 Degree to Piston Pin	4.6188 to 4.6198"	117.3175 to 117.3429 mm
Minimum Service Limit	4.6178"	117.2921 mm
ID of Piston Pin Bore	1.6251 to 1.6253"	41.2775 to 41.2826 mm
Maximum Service Limit	1.6258"	41.2953 mm
Width of 1st Ring Groove	0.097 to 0.098"	2.464 to 2.489 mm
Maximum Service Limit	0.0985"	2.502 mm
Width of 2nd Ring Groove	0.097 to 0.098"	2.464 to 2.489 mm
Maximum Service Limit	0.0985"	2.502 mm
Width of 3rd Ring Groove	0.188 to 0.189"	4.775 to 4.801 mm
Maximum Service Limit	0.190"	4.826 mm

Piston with 1.80" (45.72 mm) Pin Bore

Type	Cam Ground	
Material	Aluminum Alloy	
OD at Bottom, 90 Degree to Piston Pin	4.6188 to 4.6198"	117.3175 to 117.3429 mm
Minimum Service Limit	4.6178"	117.2921 mm
ID of Piston Pin Bore	1.8001 to 1.8005"	45.7225 to 45.7327 mm
Maximum Service Limit	1.8010"	45.7454 mm
Width of 1st Ring Groove	Not Measureable	
Width of 2nd Ring Groove	Not Measureable	
Width of 3rd Ring Groove	0.188 to 0.189"	4.775 to 4.801 mm
Maximum Service Limit	0.190"	4.826 mm

Piston Pin for Piston with 1.62" (41.15 mm) Pin Bore

Type	Floats	
OD of Pin	1.6244 to 1.6246"	41.2598 to 41.2648 mm

Piston Pin for Piston with 1.80" (45.72 mm) Pin Bore

Type	Floats	
OD of Pin	1.7994 to 1.7996"	45.7048 to 45.7098 mm

<https://www.ebooklibonline.com>

Hello dear friend!

Thank you very much for reading.

Enter the link into your browser.

The full manual is available for immediate download.

<https://www.ebooklibonline.com>