

1. Trim along dashed line.
2. Slide into pocket on Binder Spine.

TYPE 1-4

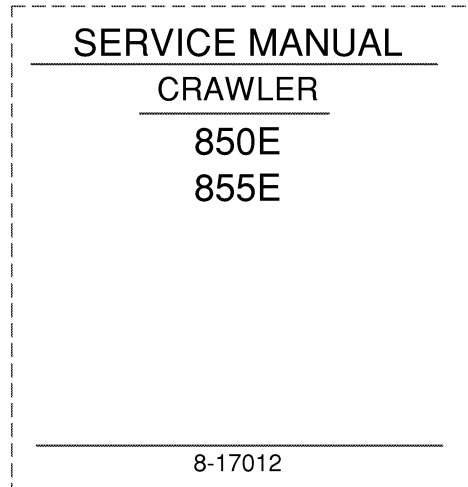

1. Trim along dashed line.
2. Slide into pocket on Binder Spine.

TYPE 1-4

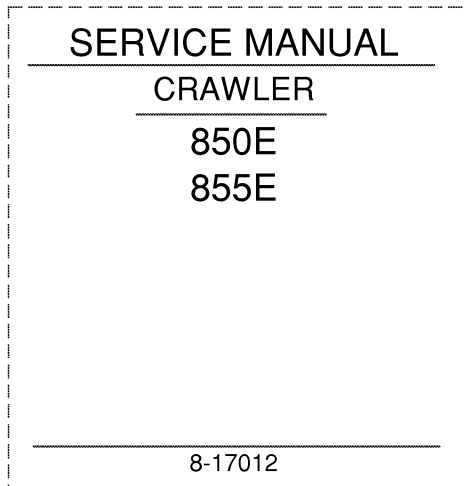

1. Trim along dashed line.
2. Slide into pocket on Binder Spine.

TYPE 1-4

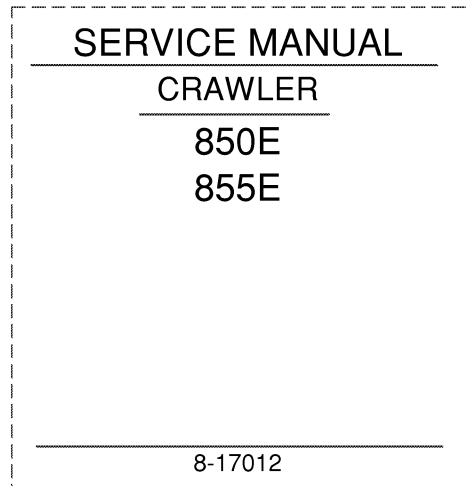

1. Trim along dashed line.
2. Slide into pocket on Binder Spine.

TYPE 1-4

850E/855E Crawler
Service Manual
8-17012
Table of Contents

Description	Section No.	Form No.
General		
Tab 1		
Section Index - General		8-19180
Standard Torque Specifications	1001	8-71601
Fluids and Lubricants	1002	8-18970
Loctite Product Chart		8-98900
Engine		
Tab 2		
Section Index - Engine		7-43920
Engine Stall Tests	2000	8-19190
Removal and Installation and Radiator Removal and Installation	2001	8-19200
Detailed Engine Specifications	2401	8-26063
Cylinder Head and Valve Train	2415	8-26073
Cylinder Block	2425	8-28084
Lubrication System	2445	8-26093
Cooling System	2455	8-26103
Turbocharger	2465	8-26110
Turbocharger Failure Analysis	2565	9-78235
Fuel System		
Tab 3		
Section Index - Fuel System		8-19210
Fuel System and Filters	3410	8-26131
Fuel Injection Pump - CAV	3411	8-97711
Fuel Injection Pump - Bosch	3412	8-26143
Fuel Injectors	3413	8-26152
Electrical		
Tab 4		
Section Index - Electrical		8-19220
Electrical Specifications, Troubleshooting and Schematic	4001	8-19230
Starter and Starter Solenoid	4002	8-73830
Batteries	4003	8-11361
Instrument panel and Gauges	4004	8-19020
Alternator	4009	8-16570
Track		
Tab 5		
Section Index - Track		8-14520
Undercarriage Fundamentals	5001	8-99830
Inspection of Track System Components	5501	8-19160
Case Lubricated Track	5504	8-14531
Sealed Track and Track Frame	5506	8-14541
Idler, Track Adjuster and Recoil Housing	5508	8-14550
Sprocket	5509	8-19240
Carrier Roller	5510	8-14570
Track Roller	5511	8-14580

Reprinted



850E/855E Crawler
Service Manual

Table of Contents

Description	Section No.	Form No.
Power Train	Tab 6	
Section Index - Power Train		8-14590
Specifications, Schematic and Troubleshooting	6002	8-19030
Torque Converter and Torque Converter Housing	6006	8-14610
Transmission Control Valve	6007	8-19040
Modulator Valve	6008	8-19050
Transmission	6016	8-19061
Final Drive	6017	8-14641
Brakes	Tab 7	
Section Index - Brakes		8-19070
Removal and Installation of Brake Valve and Removing Air from the Brake System	7001	8-19080
Brake Valve	7002	8-19090
Brakes	7003	8-19101
Hydraulics	Tab 8	
Section Index - Hydraulics		7-43890
Removal and Installation of Control Valves and Pump	8001	7-44640
Specifications, Troubleshooting and Schematics	8002	8-19250
Cleaning the Hydraulic System	8003	8-14710
Equipment Pump	8005	8-14720
Loader Control Valve	8006	8-19260
Dozer Control Valve	8007	8-19300
Cylinders	8008	8-19271
Backhoe Control Valve	8009	7-43860
Stabilizer Control Valve	8010	7-43870
Mounted Equipment	Tab 9	
Section Index - Mounted Equipment		8-19280
Pedals and Levers	9000	8-19290
Air Conditioning Troubleshooting	9001	8-18910
Discharging and Charging Air Conditioning System	9002	8-19310
Air Conditioning Compressor and Clutch	9003	8-19320
Loader	9004	8-19330
Dozer Blade	9005	8-19340
Backhoe	9006	7-34880
Ripper	9031	8-14780
ROPS Cab and Canopy	9061	8-19350
Suspension Seat	9063	7-43910

<https://www.ebooklibonline.com>

Hello dear friend!

Thank you very much for reading.

Enter the link into your browser.

The full manual is available for immediate download.

<https://www.ebooklibonline.com>

Section 1001

STANDARD TORQUE SPECIFICATIONS

CASE CORPORATION
700 State Street
Racine, WI 53404 U.S.A.

CASE CANADA CORPORATION
3350 South Service Road
Burlington, ON L7N 3M6 CANADA

Rac 8-71601

© 1994 Case Corporation
Printed in U.S.A.
Issued November, 1991

TABLE OF CONTENTS

TORQUE SPECIFICATIONS - DECIMAL HARDWARE 2

TORQUE SPECIFICATIONS - METRIC HARDWARE 3

TORQUE SPECIFICATIONS - STEEL HYDRAULIC FITTINGS 4

TORQUE SPECIFICATIONS - STEEL HYDRAULIC FITTINGS 5

TORQUE SPECIFICATIONS - DECIMAL HARDWARE

Use the torques in this chart when special torques are not given. These torques apply to fasteners with both UNC and UNF threads as received from suppliers dry, or when lubricated with engine oil. Not applicable if special graphities, Molydisulfide greases, or other extreme pressure lubricants are used.

Grade 5 Bolts, Nuts, and Studs		
		
Size	Pound-Inches	Newton metres
1/4 inch	108 to 132	12 to 15
5/16 inch	204 to 252	23 to 28
3/8 inch	420 to 504	48 to 57
Size	Pound-Feet	Newton metres
7/16 inch	54 to 64	73 to 87
1/2 inch	80 to 96	109 to 130
9/16 inch	110 to 132	149 to 179
5/8 inch	150 to 180	203 to 244
3/4 inch	270 to 324	366 to 439
7/8 inch	400 to 480	542 to 651
1.0 inch	580 to 696	787 to 944
1-1/8 inch	800 to 880	1085 to 1193
1-1/4 inch	1120 to 1240	1519 to 1681
1-3/8 inch	1460 to 1680	1980 to 2278
1-1/2 inch	1940 to 2200	2631 to 2983

Grade 8 Bolts, Nuts, and Studs		
		
Size	Pound-Inches	Newton metres
1/4 inch	144 to 180	16 to 20
5/16 inch	288 to 348	33 to 39
3/8 inch	540 to 648	61 to 73
Size	Pound-Feet	Newton metres
7/16 inch	70 to 84	95 to 114
1/2 inch	110 to 132	149 to 179
9/16 inch	160 to 192	217 to 260
5/8 inch	220 to 264	298 to 358
3/4 inch	380 to 456	515 to 618
7/8 inch	600 to 720	814 to 976
1.0 inch	900 to 1080	1220 to 1465
1-1/8 inch	1280 to 1440	1736 to 1953
1-1/4 inch	1820 to 2000	2468 to 2712
1-3/8 inch	2380 to 2720	3227 to 3688
1-1/2 inch	3160 to 3560	4285 to 4827

NOTE: Use thick nuts with Grade 8 bolts.

TORQUE SPECIFICATIONS - METRIC HARDWARE

Use the following torques when specifications are not given.

These values apply to fasteners with coarse threads as received from supplier, plated or unplated, or when lubricated with engine oil. These values do not apply if graphite or Molydisulfide grease or oil is used.

Grade 8.8 Bolts, Nuts, and Studs		
		
Size	Pound-Inches	Newton metres
M4	24 to 36	3 to 4
M5	60 to 72	7 to 8
M6	96 to 108	11 to 12
M8	228 to 276	26 to 31
M10	456 to 540	52 to 61
Size	Pound-Feet	Newton metres
M12	66 to 79	90 to 107
M14	106 to 127	144 to 172
M16	160 to 200	217 to 271
M20	320 to 380	434 to 515
M24	500 to 600	675 to 815
M30	920 to 1100	1250 to 1500
M36	1600 to 1950	2175 to 2600

Grade 10.9 Bolts, Nuts, and Studs		
		
Size	Pound-Inches	Newton metres
M4	36 to 48	4 to 5
M5	84 to 96	9 to 11
M6	132 to 156	15 to 18
M8	324 to 384	37 to 43
Size	Pound-Feet	Newton metres
M10	54 to 64	73 to 87
M12	93 to 112	125 to 150
M14	149 to 179	200 to 245
M16	230 to 280	310 to 380
M20	450 to 540	610 to 730
M24	780 to 940	1050 to 1275
M30	1470 to 1770	2000 to 2400
M36	2580 to 3090	3500 to 4200

Grade 12.9 Bolts, Nuts, and Studs



Usually the torque values specified for grade 10.9 fasteners can be used satisfactorily on grade 12.9 fasteners.

TORQUE SPECIFICATIONS - STEEL HYDRAULIC FITTINGS

Tube OD Hose ID	Thread Size	Pound- Inches	Newton metres
37 Degree Flare Fitting			
1/4 inch 6.4 mm	7/16-20	72 to 144	8 to 16
5/16 inch 7.9 mm	1/2-20	96 to 192	11 to 22
3/8 inch 9.5 mm	9/16-18	120 to 300	14 to 34
1/2 inch 12.7 mm	3/4-16	180 to 504	20 to 57
5/8 inch 15.9 mm	7/8-14	300 to 696	34 to 79
Tube OD Hose ID	Thread Size	Pound- Inches	Newton metres
3/4 inch 19.0 mm	1-1/16-12	40 to 80	54 to 108
7/8 inch 22.2 mm	1-3/16-12	60 to 100	81 to 135
1.0 inch 25.4 mm	1-5/16-12	75 to 117	102 to 158
1-1/4 inch 31.8 mm	1-5/8-12	125 to 165	169 to 223
1-1/2 inch 38.1 mm	1-7/8-12	210 to 250	285 to 338

Tube OD Hose ID	Thread Size	Pound- Inches	Newton metres
Straight Threads with O-ring			
1/4 inch 6.4 mm	7/16-20	144 to 228	16 to 26
5/16 inch 7.9 mm	1/2-20	192 to 300	22 to 34
3/8 inch 9.5 mm	9/16-18	300 to 480	34 to 54
1/2 inch 12.7 mm	3/4-16	540 to 804	57 to 91
Tube OD Hose ID	Thread Size	Pound- Inches	Newton metres
5/8 inch 15.9 mm	7/8-14	58 to 92	79 to 124
3/4 inch 19.0 mm	1-1/16-12	80 to 128	108 to 174
7/8 inch 22.2 mm	1-3/16-12	100 to 160	136 to 216
1.0 inch 25.4 mm	1-5/16-12	117 to 187	159 to 253
1-1/4 inch 31.8 mm	1-5/8-12	165 to 264	224 to 357
1-1/2 inch 38.1 mm	1-7/8-12	250 to 400	339 to 542

Split Flange Mounting Bolts		
Size	Pound- Inches	Newton metres
5/16-18	180 to 240	20 to 27
3/8-16	240 to 300	27 to 34
7/16-14	420 to 540	47 to 61
Size	Pound- Feet	Newton metres
1/2-13	55 to 65	74 to 88
5/8-11	140 to 150	190 to 203

Section

2001

ENGINE REMOVAL AND INSTALLATION
RADIATOR REMOVAL AND INSTALLATION

TABLE OF CONTENTS

RADIATOR REMOVAL.....2

RADIATOR INSTALLATION6

ENGINE REMOVAL.....10

ENGINE INSTALLATION19

ILLUSTRATION OF ENGINE MOUNTING.....27

RADIATOR REMOVAL

STEP 1

Loosen the cap screws that hold the guards in position below the engine and torque converter.

STEP 2

Before removing the cap screws, raise a jack into contact with the guard to hold the guard in position when the cap screws are removed to prevent personal injury.

STEP 3

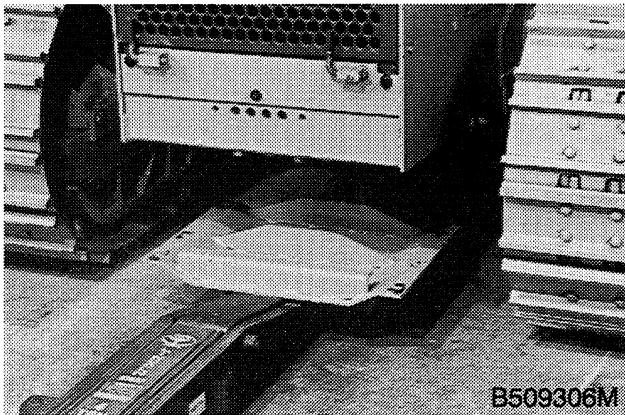

Remove the cap screws. Lower the guard and remove the guard from under the machine.

STEP 4

If the machine is a loader, raise the loader frame and lower the strut onto the lift cylinder.

STEP 5



Remove the upper side panels from the machine.

STEP 6

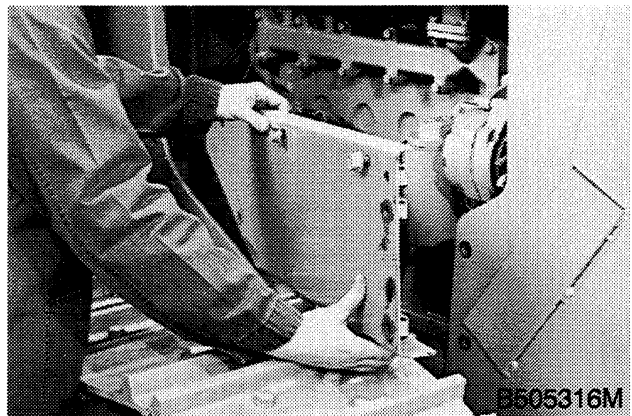

Remove the lower side panels from the machine.

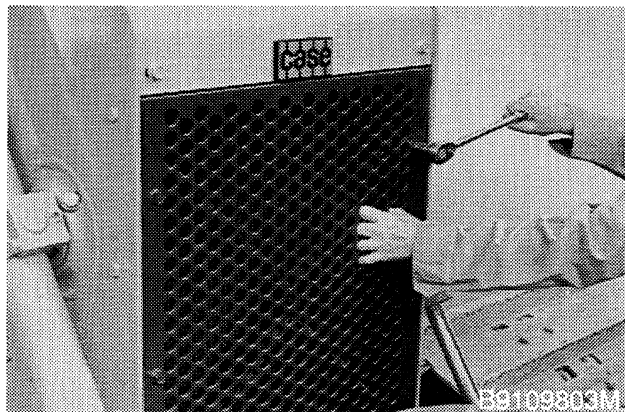
STEP 7

Remove the cap screws that hold the grille in position.

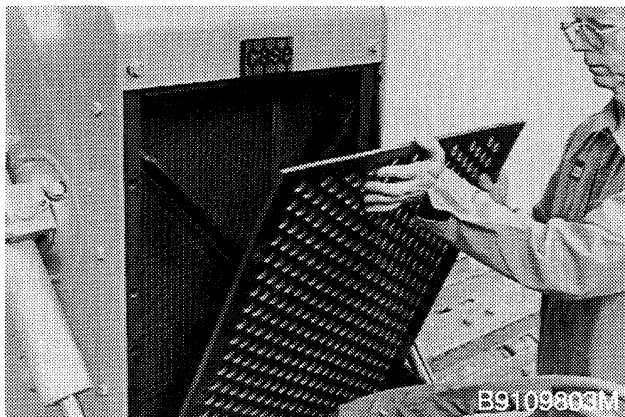
STEP 8

Tilt the grille forward and remove the grille from the mounting pins.

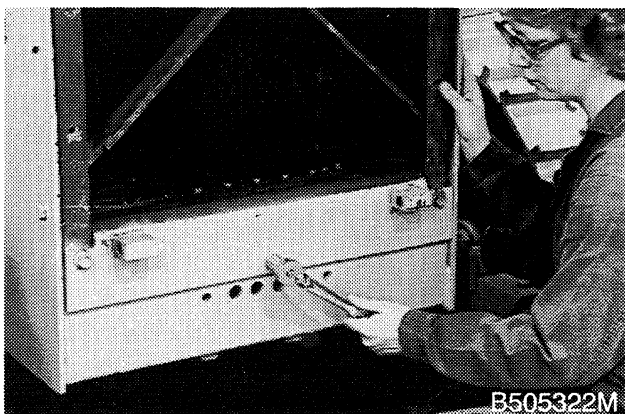
STEP 9

Remove the cap screws that fasten the mounting bracket to the frame.

STEP 10

Remove the mounting bracket.

STEP 11

Remove the radiator cap.

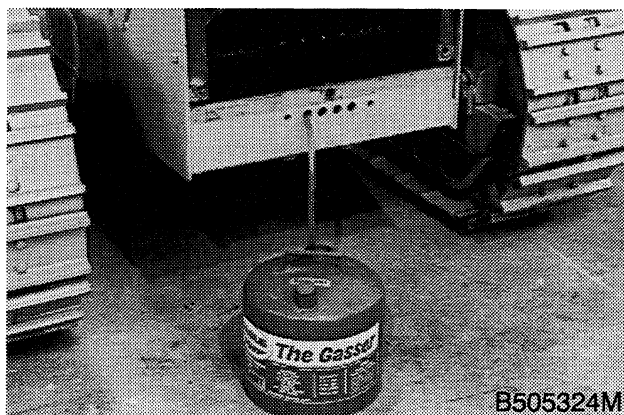
STEP 12

Connect a tube to the radiator drain valve and drain the coolant from the radiator. Use clean containers if the coolant is to be used again.

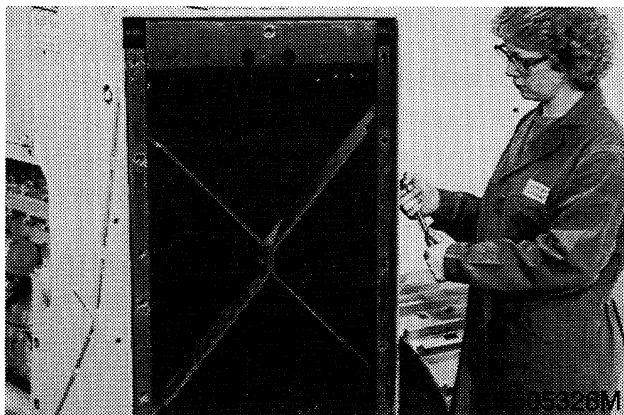
STEP 13

Remove the nuts, lock washers, and bolts that hold the left grille mount in position.

STEP 14

Remove the left grille mount.

STEP 15

Remove the nuts, lock washers, and bolts that hold the left and right grille mount in position.

STEP 16

Remove the left and right grille mount and cross brace from the machine.

STEP 17

Disconnect horn wires from horns.

STEP 18

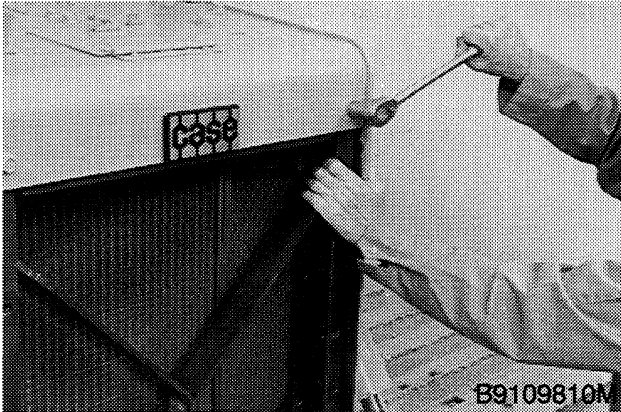

Remove the four nuts, lock washers, and cap screws that fasten the top plate to the frame.

STEP 19

Remove the bolt and lock washer that fasten the center support to the top plate.

STEP 20

Remove the top plate from the machine.

STEP 21

Remove the bolt and lock nut that fasten the clamp on the tube for the oil cooler to the radiator shroud.

STEP 22

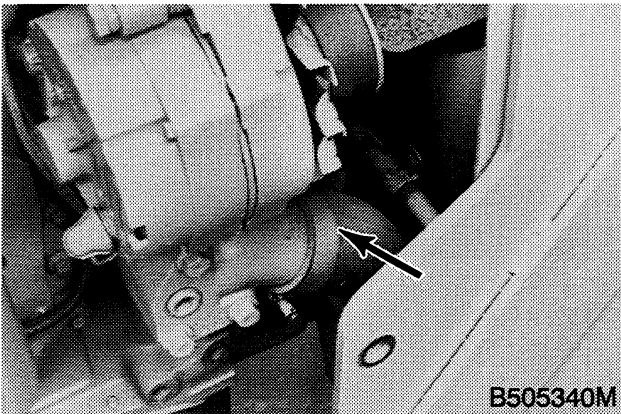

Loosen the clamp that fastens the bottom radiator hose to the water pump.

STEP 23

Remove the bottom radiator hose from the water pump.

STEP 24

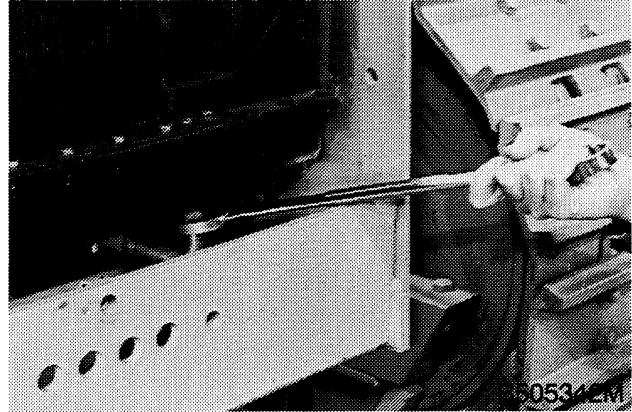

Disconnect the tube from the fitting in the bottom of the oil cooler.

STEP 25

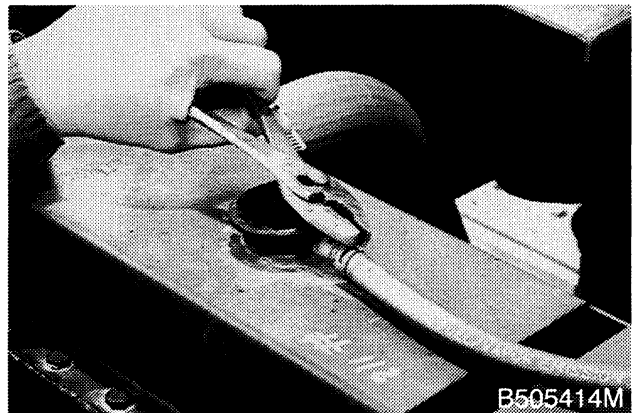

Disconnect the coolant reservoir hose from the radiator.

STEP 26

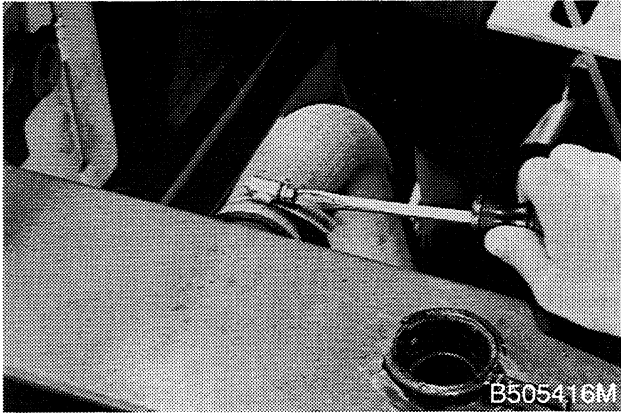

Loosen the clamp that fastens the top radiator hose to the radiator.

STEP 27

Remove the top radiator hose from the radiator.

STEP 28

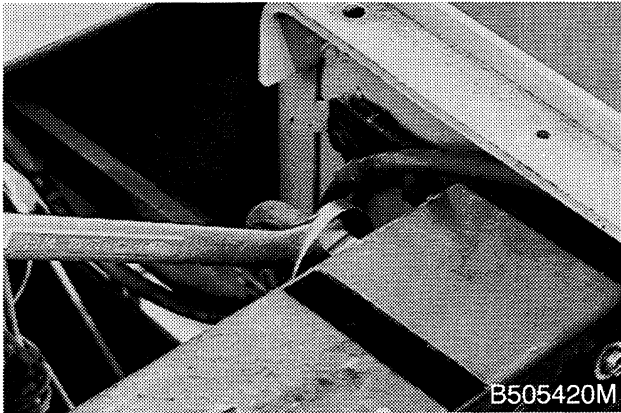

Disconnect the tube from the fitting in the top of the oil cooler.

STEP 29

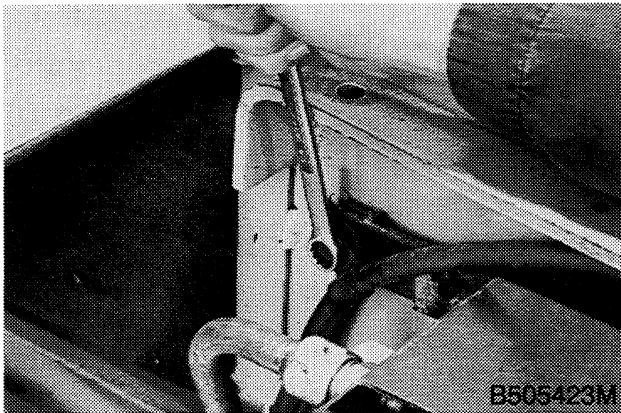

Remove the cap screws, lock washers, and flat washers that fasten the top radiator supports to the frame. Move the hose from the radiator to the coolant reservoir out of the way.

STEP 30

Connect acceptable lifting equipment to the radiator.

STEP 31

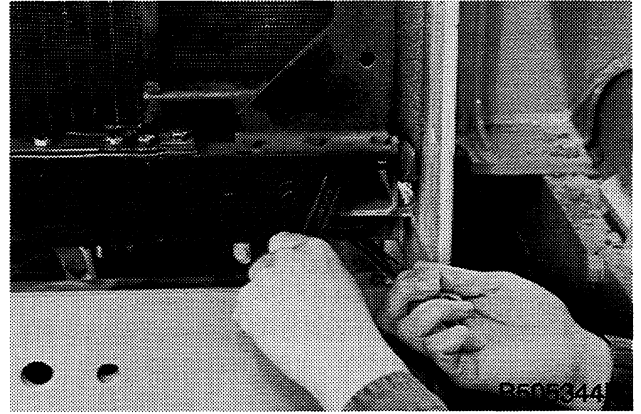

Remove the nuts, flat washers, and bolts that fasten the radiator to the radiator mounts.

STEP 32

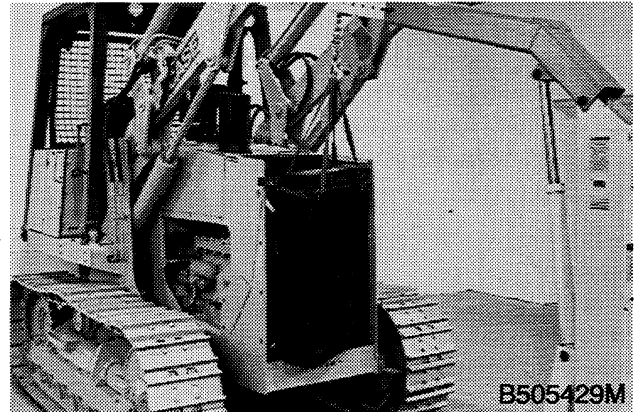

Remove the radiator from the machine.

RADIATOR INSTALLATION

STEP 33

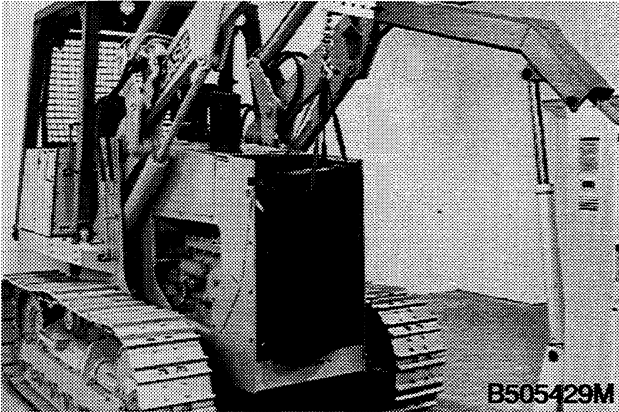

Put the radiator in position in the machine.

STEP 34

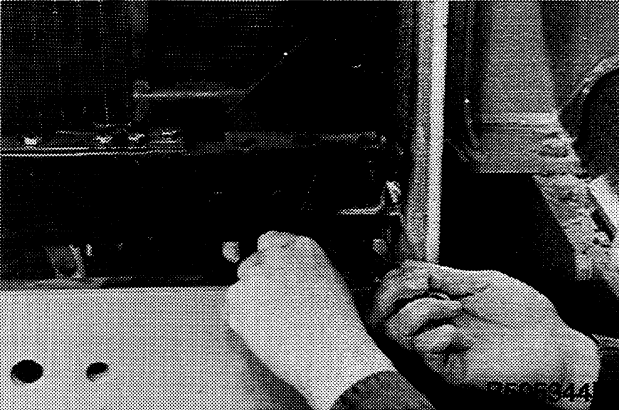

Install the nuts, flat washers, and bolts that fasten the radiator to the radiator mounts. Tighten the bolts to 50 to 60 pound-feet (68 to 82 Nm).

STEP 35

Remove the lifting equipment from the radiator.

STEP 36

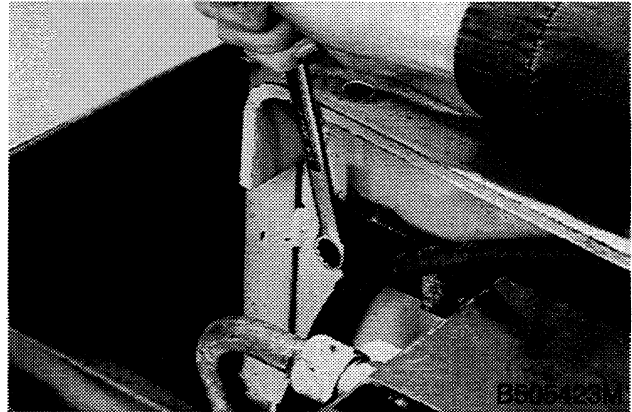

Install the cap screws, lock washers, and flat washers that fasten the top radiator supports to the frame and install the clamp on the hose from the radiator to the coolant reservoir.

STEP 37

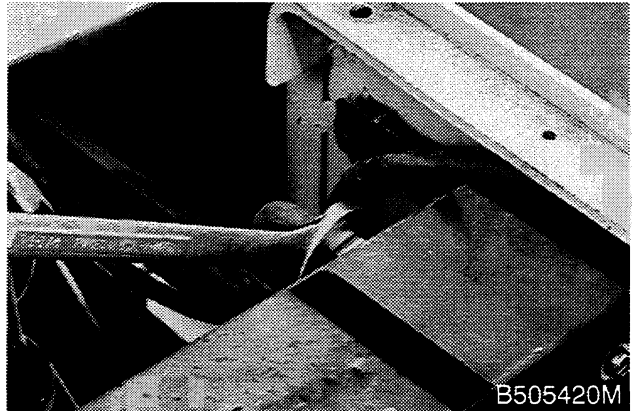

Connect the tube to the fitting at the top of the oil cooler.

STEP 38

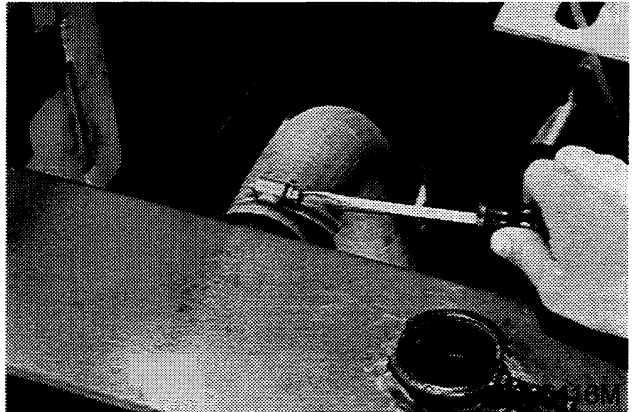

Install the upper radiator hose on the radiator. Tighten the clamp.

STEP 39

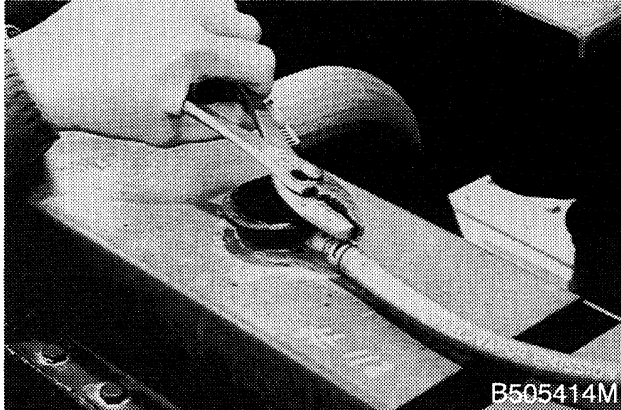

Connect the hose from the coolant reservoir to the radiator.

STEP 40

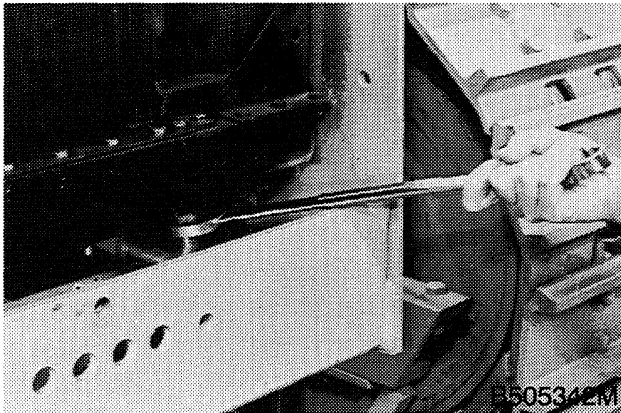

Connect the tube to the fitting in the bottom of the oil cooler.

STEP 41

Install the bolt and self-locking nut that fastens the clamp on the tube for the oil cooler to the radiator shroud.

STEP 42

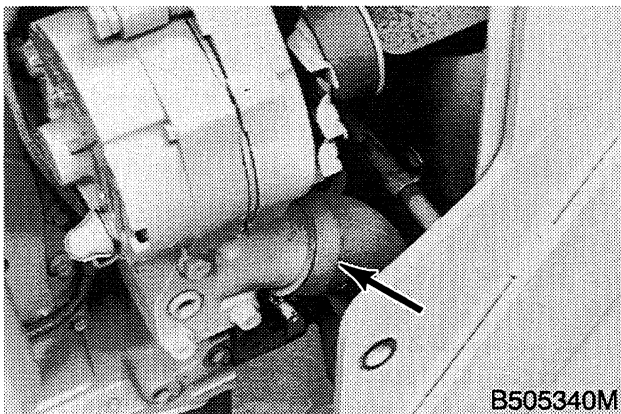

Install the lower radiator hose on the water pump. Tighten the clamp.

STEP 43



Fill the radiator. If new coolant is being installed, the coolant must be at least half permanent antifreeze. Install the radiator cap. Fill the coolant reservoir to the FULL mark.

STEP 44

Make sure the crankcase has been filled with the correct engine oil. See Section 1002.

STEP 45

If the transmission was drained, see Section 1002 and fill the transmission.

STEP 46

Start the engine and run the engine at low idle. Check to make sure that the gauges show the correct indications. Check for leaks. Stop the engine.

STEP 47

Put the top plate in position on the machine.

STEP 48

Connect horn wires to horns.

STEP 49

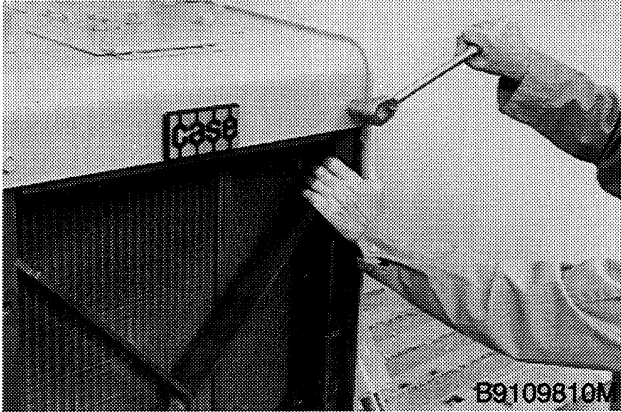

Install the bolt and lock washer that fasten center support to the top plate. Install the four nuts, lock washers, and cap screws that fasten the top plate to the frame.

STEP 51

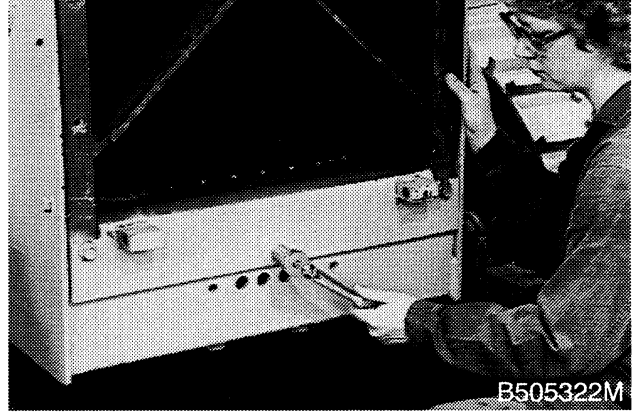

Put the mounting bracket in position on the frame. Install the cap screws that fasten the mounting bracket to the frame.

STEP 50



Put the right grille mount and cross brace in position on the frame. Install the nuts, lock washers, and bolts that fasten the grille mount and cross brace to the frame. Put the grille mount in position on the frame. Install the nuts, lock washers, and bolts that fasten the grille mount and cross brace to the frame.

STEP 52

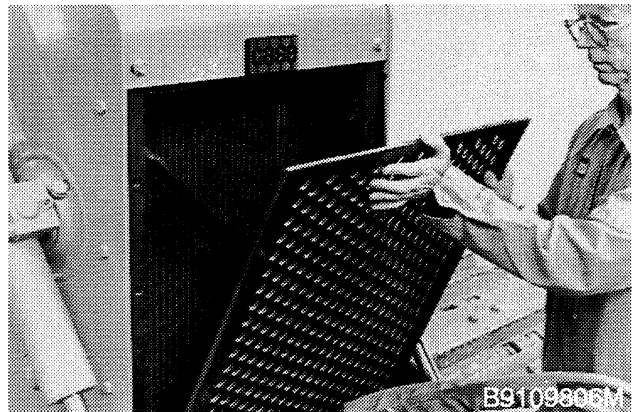

Engage the shafts on the grille with the holes in the mounting brackets. Raise the grille into position.

STEP 53

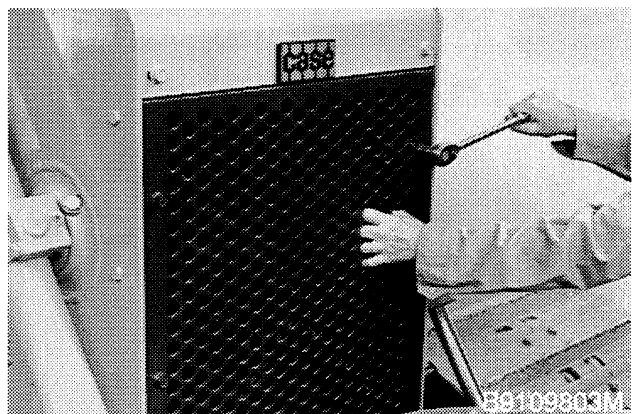

Hold the grille in position and install the cap screws that fasten the grille to the radiator and grille mounts.

STEP 54

Install the cotter pin in each shaft at the bottom of the grille.

STEP 55

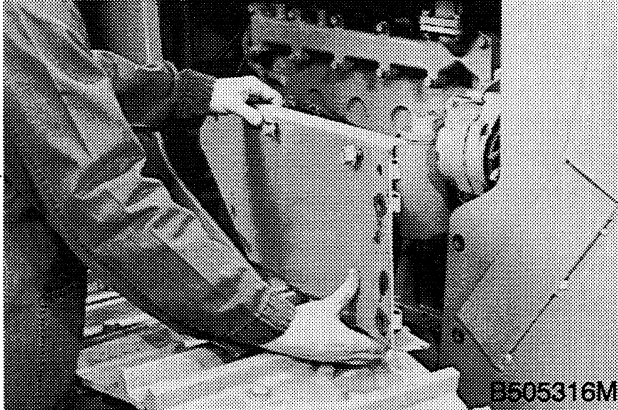

Install the lower side panels on the machine. Tighten the cap screws.

STEP 56

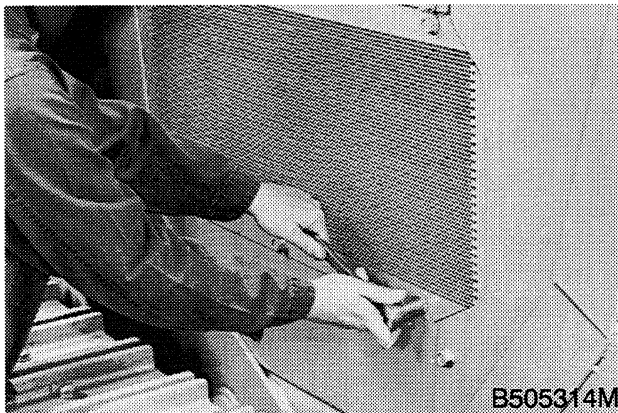

Install the upper side panels on the machine. Tighten the cap screws.

STEP 57

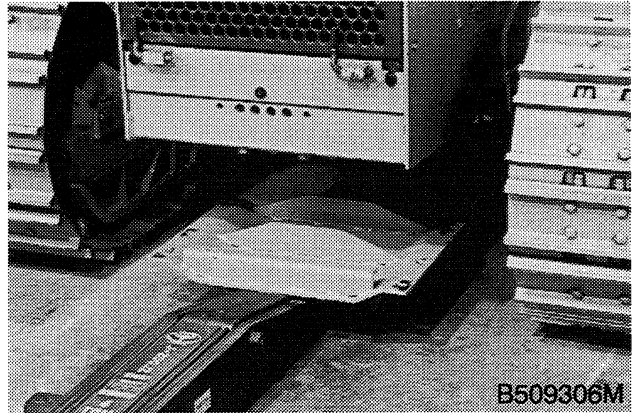

Install the guards below the engine, torque converter, and transmission using a jack to raise guards into position.

STEP 58

Install, but do not tighten, the cap screws that fasten the guard in position.

STEP 59

Install the remainder of the guards. Tighten the cap screws that hold each guard in position.

STEP 60

If the machine is a loader, fasten the strut to the loader frame and lower the loader frame.

ENGINE REMOVAL

STEP 61

Do Radiator Removal in this section.

Because the only support for the torque converter is the engine, the torque converter must be removed with the engine.

STEP 62

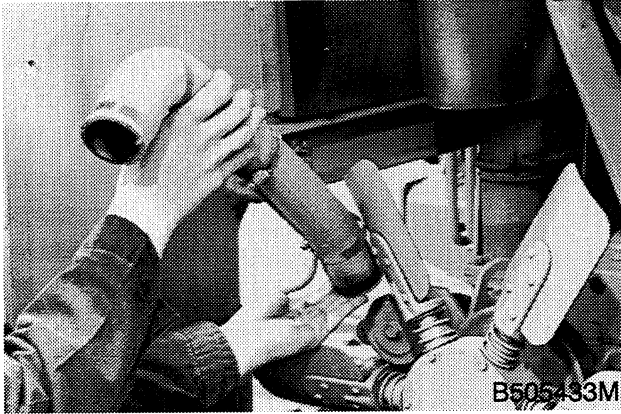

Remove the top radiator hose from the engine.

STEP 63

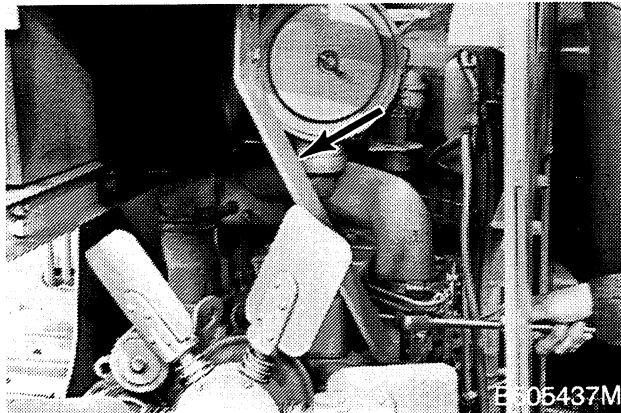

Remove the muffer support from the engine.

STEP 64

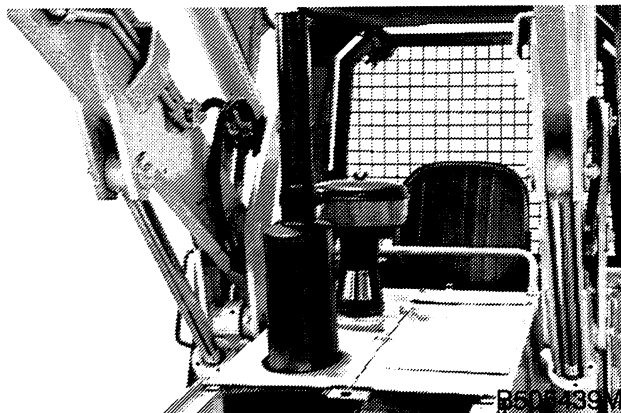

Remove the extension pipe from the muffer.

STEP 65



Remove the muffer from the engine. Remove the hoods from the machine.

STEP 66

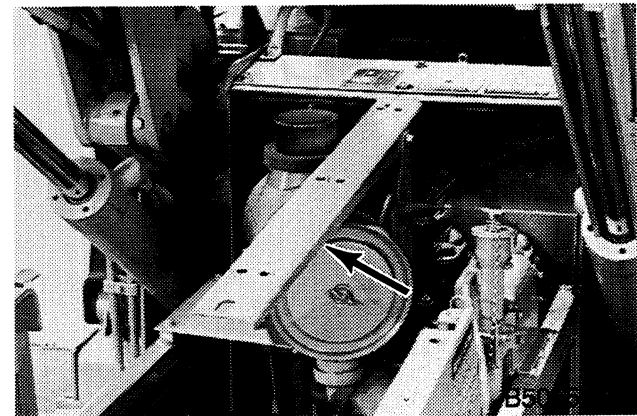

Remove the center support from the machine.

STEP 67

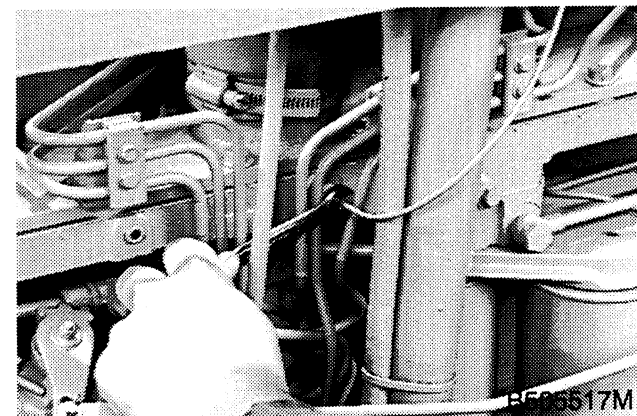

Disconnect the fitting from the nozzle for the ether injection system in the intake manifold.

STEP 68

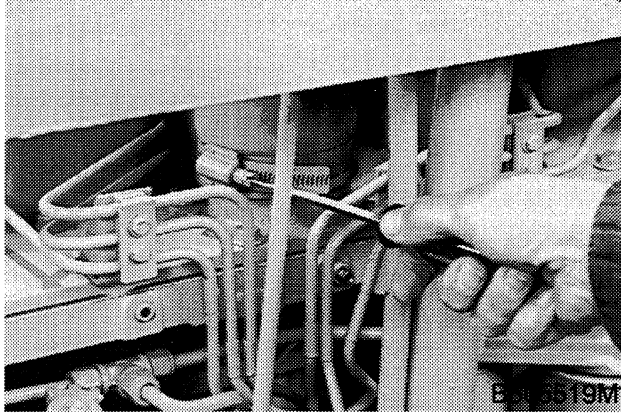

Loosen the clamp on the hose for the air cleaner.

STEP 69

Remove the hose for the air cleaner from the intake manifold or turbocharger.

STEP 70

Cover the opening in the intake manifold.

STEP 71

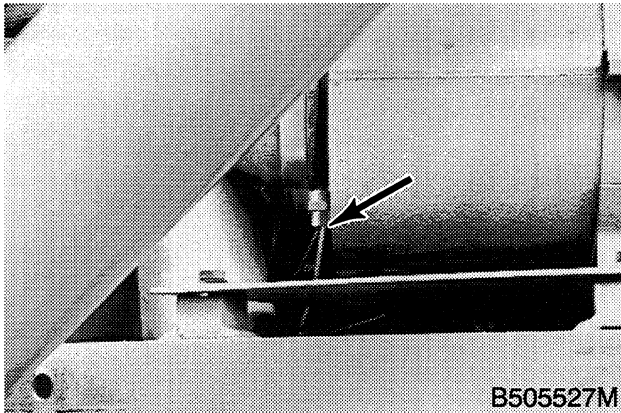

Disconnect the tube from the air cleaner.

STEP 72

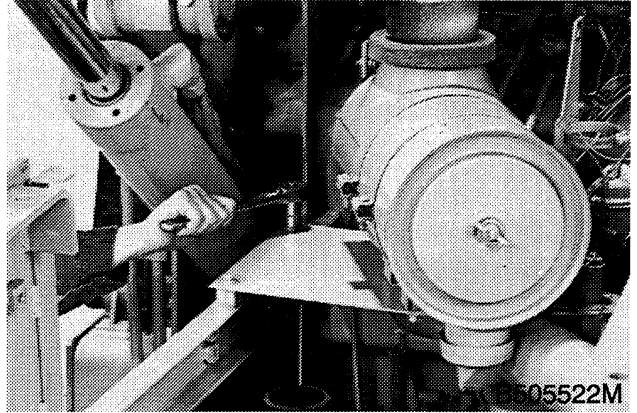

Remove the cap screws and lock washers that fasten the air cleaner mounting bracket to the machine.

STEP 73

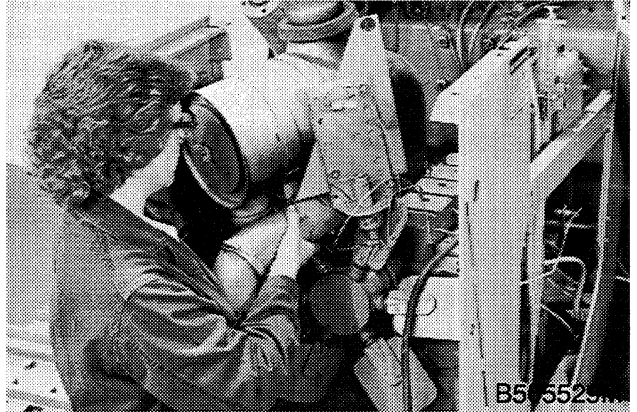

Remove the air cleaner, ether injection system, and mounting bracket from the machine.

STEP 74

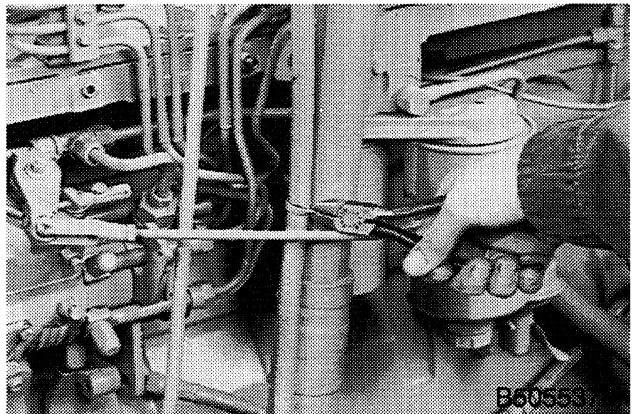

Remove the tie strap that fastens the coolant reservoir hose to the engine oil fill tube.

STEP 75

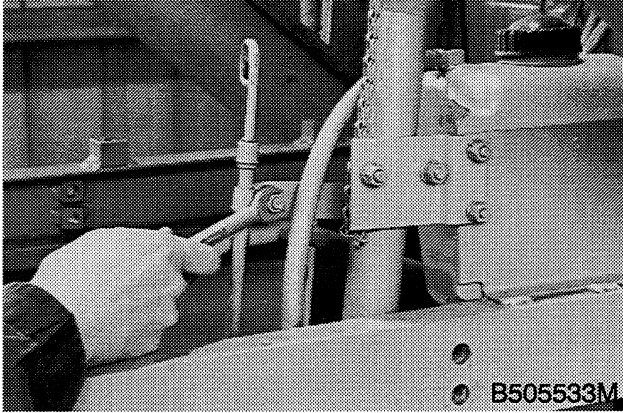

Remove the bolt, lock washer, flat washer, and nut that fasten the clamp on the engine oil dipstick tube to the bracket.

STEP 76

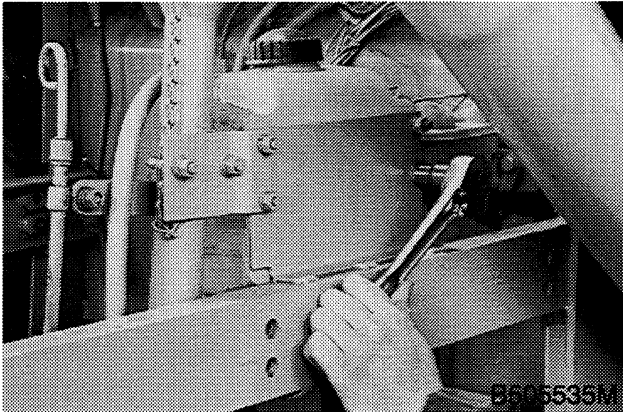

Remove the bolts, lock washers, and nuts that fasten the coolant reservoir to the mounting bracket.

STEP 77

Remove the coolant reservoir from the machine.

STEP 78

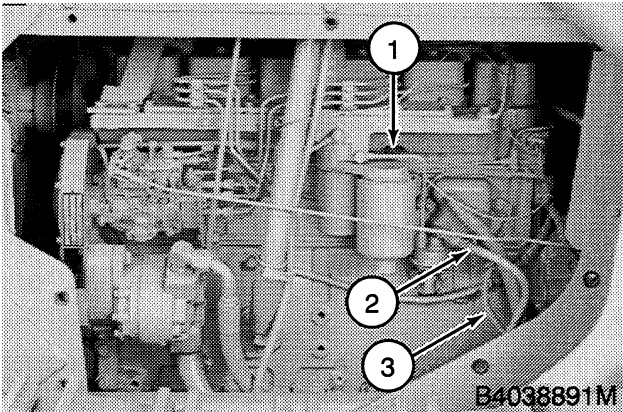

- 1. Engine Temperature Sensor
- 2. To Fuel Pump
- 3. From Fuel Injectors

Disconnect and remove the accelerator rod from the fuel injection pump and the throttle cross shaft.

STEP 79

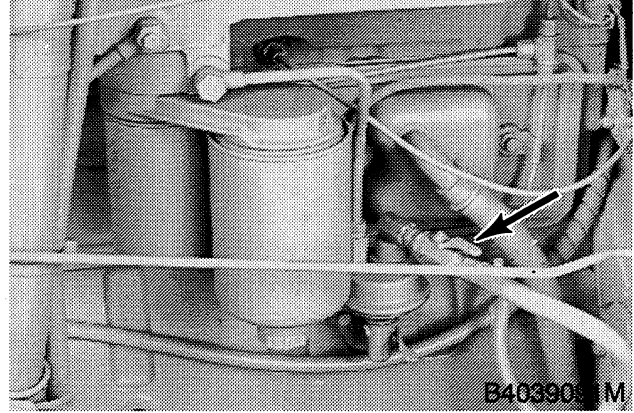

Close the fuel shutoff valve in the fuel lines.

STEP 80

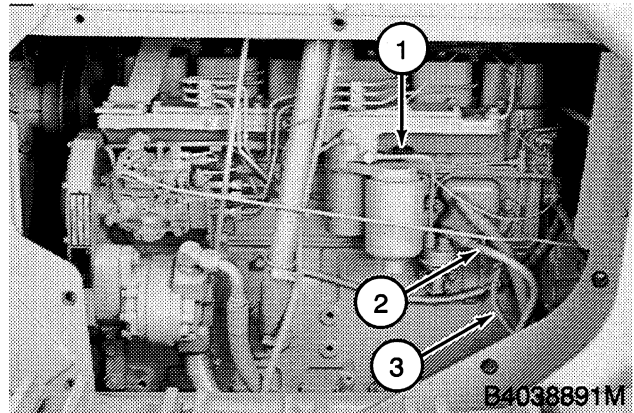

- 1. Engine Temperature Sensor
- 2. To Fuel Pump
- 3. From Fuel Injectors

Completely loosen the nut that holds the engine temperature sensor in position. Remove the engine temperature sensor from the engine.

STEP 81

Loosen the clamp on the hose to the fuel pump. Remove the hose from the fuel pump.

STEP 82

Loosen the clamp on the hose from the fuel injectors. Remove the hose from the fuel injector line.

STEP 83

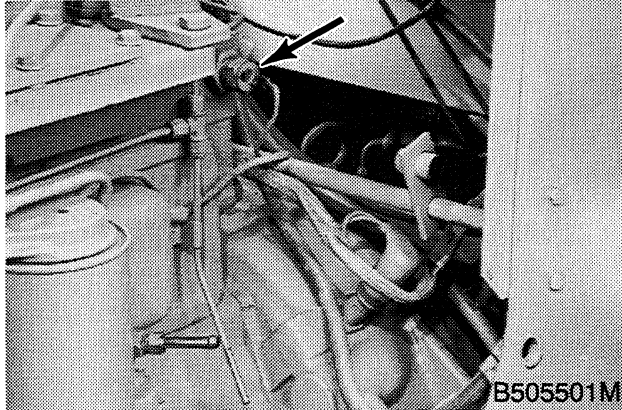

Remove the wires from the engine temperature switch for the ether injection system.

STEP 84

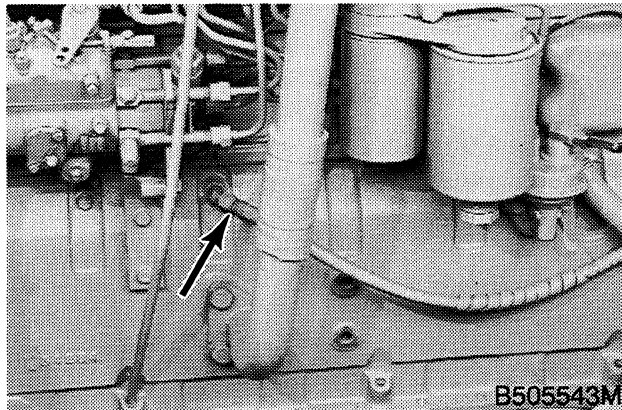

Disconnect the hose for the engine oil pressure gauge from the fitting in the engine.

STEP 85

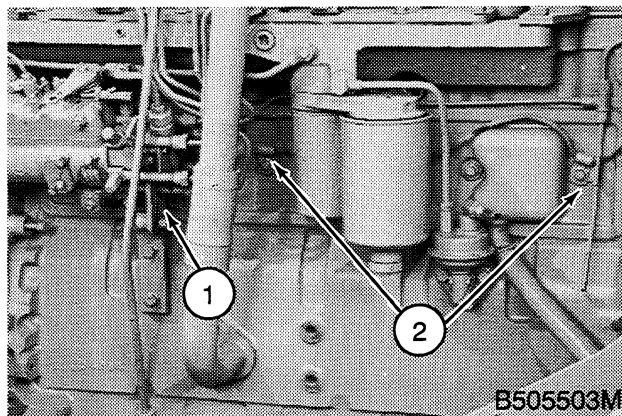

- 1. Wire for Fuel Injection Pump
- 2. Clamps

Remove the wire from the fuel injection pump. Loosen and remove the cap screws and rubber washers from the clamps that fasten the wiring harness to the engine.

STEP 86

Move the wiring harness out of the way.

STEP 87

Install the cap screws and rubber washers in the holes that the cap screws and rubber washers were removed from.

STEP 88

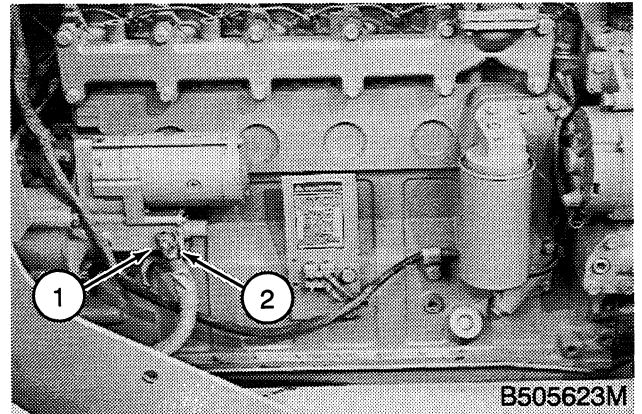

- 1. Battery Terminal
- 2. Switch Terminal

Disconnect the battery cable and wire from the battery terminal. Disconnect the wire from the switch terminal.

STEP 89

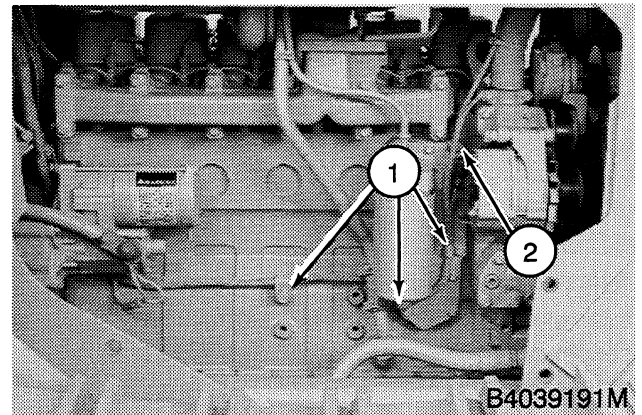

- 1. Cap Screws for Wiring Harness
- 2. Wires for Alternator

Disconnect the wires from the alternator. Remove the cap screws from the clamps that fasten the wiring harness to the engine.

STEP 90

Install the cap screws in the holes that the cap screws were removed from.

STEP 91

Move the wiring harness out of the way.

STEP 92

Remove the floor plates and the transmission under-carriage guard.

STEP 93

Remove the cap screw that fastens the negative battery cable to the torque converter housing.

STEP 94

Remove the cap screw from the clamp that fastens the tube for the torque converter temperature gauge to the torque converter housing.

STEP 95

Loosen the transmission dipstick to relieve pressure in the lines.

STEP 96

Remove the hose from the fitting in the right side of the torque converter housing. Put a plug in the hose and a cap on the fitting.

STEP 97

Remove the hose from the fitting in the left side of the torque converter housing. Put a plug in the hose and a cap on the fitting.

STEP 98

Remove the tee fitting from the top of the torque converter housing. Install a cap on the tee and a plug in the torque converter housing.

STEP 99

Completely loosen the nut that holds the sensor for the torque converter temperature gauge in the tee fitting.

STEP 100

Remove the sensor from the tee fitting and put the sensor out of the way.

STEP 101

Remove the two hoses from the fittings at the bypass valve. Install plugs in the hoses and caps on the fittings.

STEP 102

Remove the cap screws that fasten the drive shaft to the universal joint at the torque converter.

STEP 103

Use a piece of wire to hold the drive shaft out of the way.

STEP 104

Remove the self-locking nut, bolt, flat washer, and insulator from both sides of the flywheel housing.

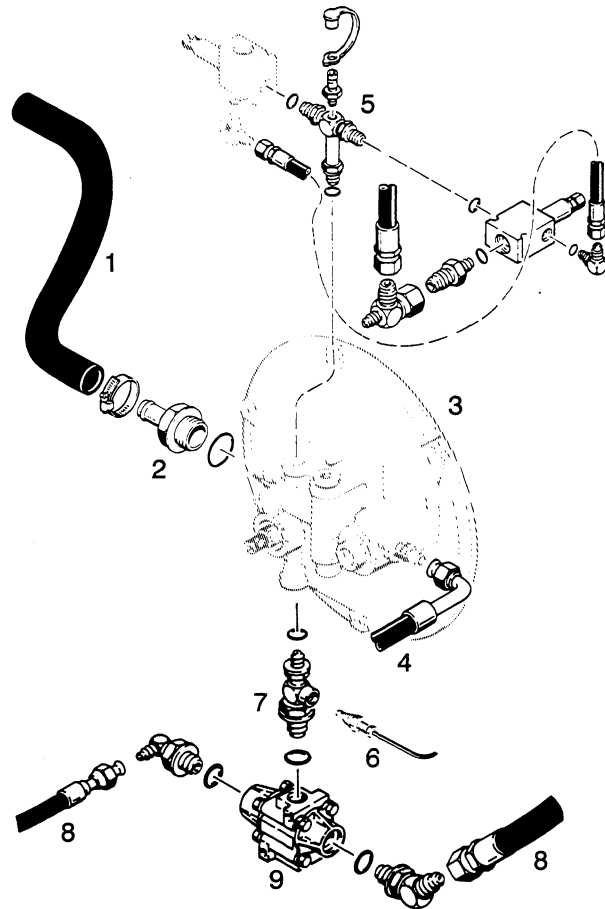

B911232N

- | | |
|-----------------------------|-----------------|
| 1. Hose | 5. Tee |
| 2. Fitting | 6. Sensor |
| 3. Torque Converter Housing | 7. Tee |
| 4. Hose | 8. Hose |
| | 9. Bypass Valve |

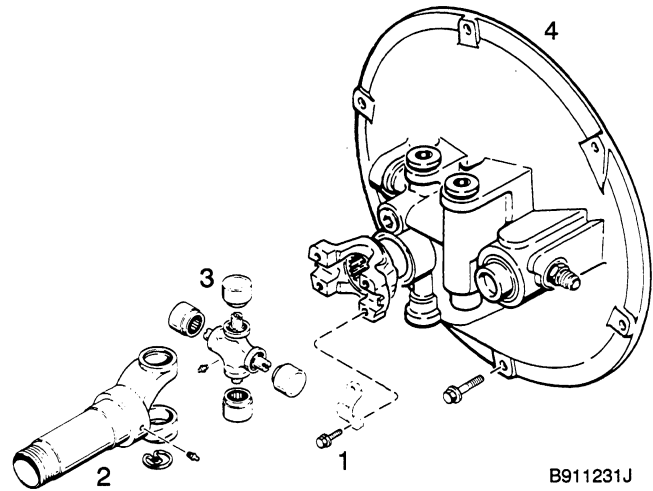

B911231J

- | | |
|----------------|-----------------------------|
| 1. Cap Screw | 3. Universal Joint |
| 2. Drive Shaft | 4. Torque Converter Housing |

STEP 105

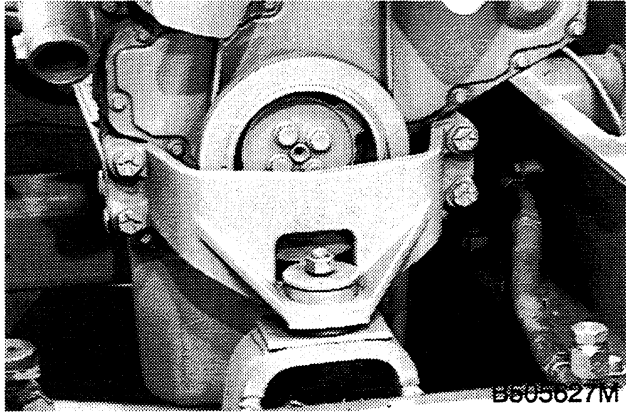

Remove the self-locking nut, bolt, flat washer, and insulator from the front engine mount.

STEP 106

Connect acceptable lifting equipment to the engine. Use the lifting eyes that are a part of the engine.

STEP 107

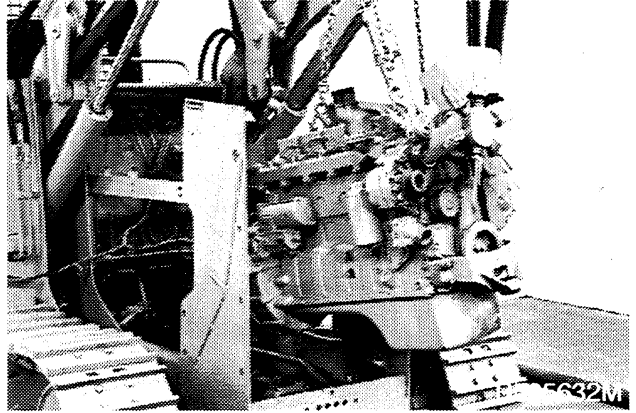

Remove the engine from the frame.

NOTE: To remove the torque converter, see Section 6006.

ENGINE INSTALLATION

STEP 108

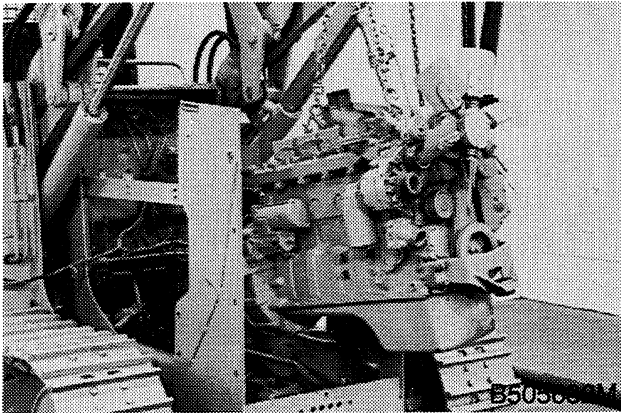

Start the engine into the frame.

STEP 109

Push the engine into the engine compartment.

STEP 110

Lower the engine into the frame and align the engine mounts.

STEP 111

Install a bottom insulator and washer between the side engine mounts and the frame.

STEP 112

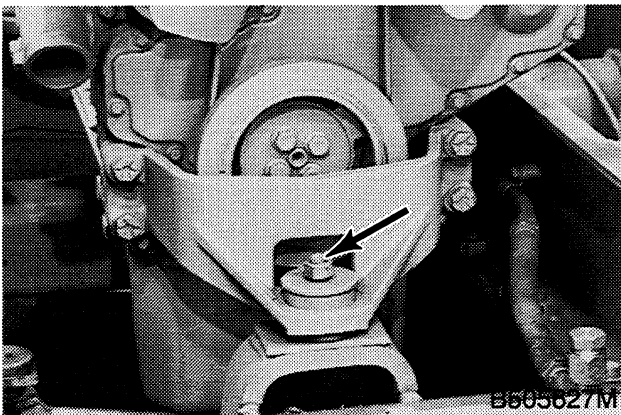

Install the top insulator and washer on the front engine mount. Install the bolt. Install the flat washer and self-locking nut. Tighten the self-locking nut.

STEP 113

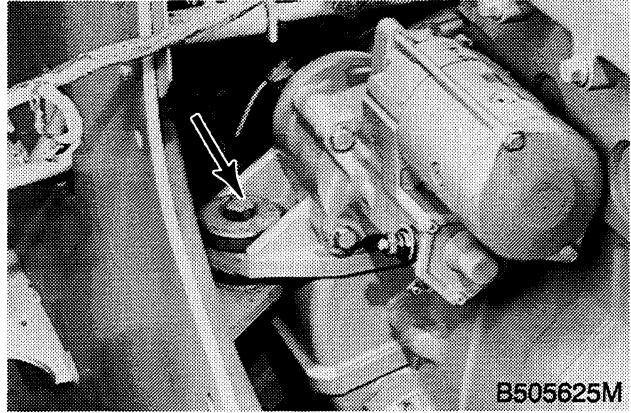

Install the top insulators and washers on the side engine mounts. Install the bolt. Install the flat washers and self-locking nuts. Tighten the self-locking nuts.

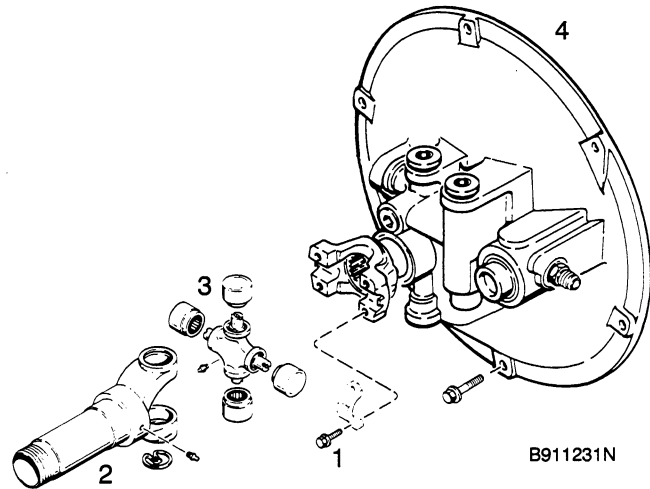

1. Cap Screw
2. Drive Shaft

3. Universal Joint
4. Torque Converter Housing

STEP 114

Align the drive shaft with the universal joint and install the cap screws that hold the drive shaft in position. Tighten the cap screws to a torque of 480 to 600 pound-inches (54 to 68 Nm).

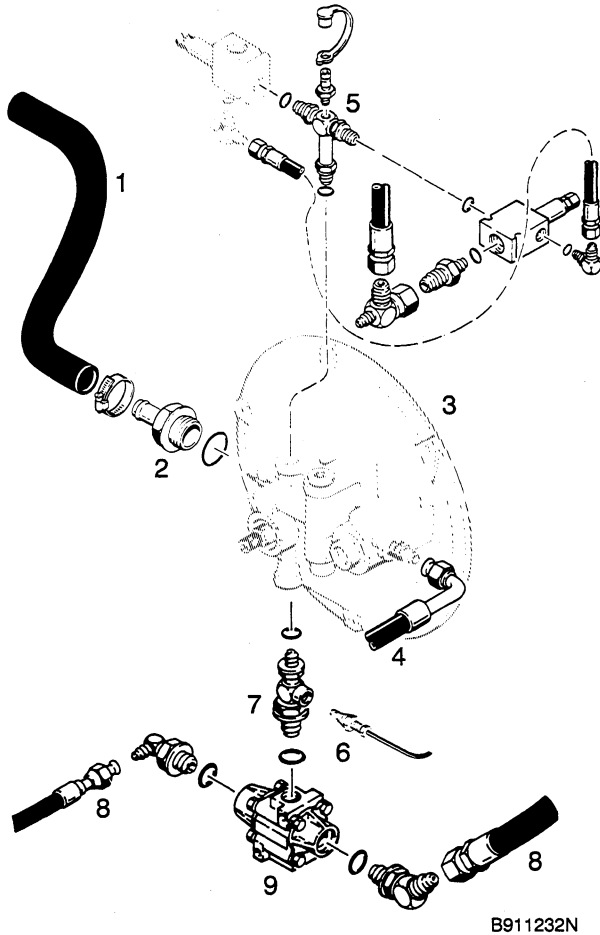

- | | |
|-----------------------------|-----------------|
| 1. Hose | 5. Tee |
| 2. Fitting | 6. Sensor |
| 3. Torque Converter Housing | 7. Tee |
| 4. Hose | 8. Hose |
| | 9. Bypass Valve |

STEP 115

Remove the plugs from the hoses at the bottom of the torque converter housing and the caps from the fittings. Connect the hoses to the fittings.

STEP 116

Install the sensor in the tee fitting.

STEP 117

Remove the plug from the torque converter housing and the cap from the tee fitting. Install the tee fitting in the top of the torque converter housing.

STEP 118

Remove the plug from the hose and the cap from the fitting. Connect the hose to the fitting at the left side of the torque converter housing.

STEP 119

Remove the plug from the hose and the cap from the fitting. Connect the hose to the fitting at the right side of the torque converter housing.

STEP 120

Install and tighten the cap screw that fastens the clamp on the tube for the torque converter temperature gauge to the torque converter housing.

STEP 121

Install and tighten the cap screw that fastens the negative battery cable to the torque converter housing.

STEP 122

Install the floor plates and transmission undercarriage guard.

STEP 123

Tighten the transmission dipstick.



Suggest:

If the above button click is invalid.

Please download this document

first, and then click the above link

to download the complete manual.

Thank you so much for reading

STEP 124

Remove the cap screws that fasten the wiring harness to the engine.

STEP 125

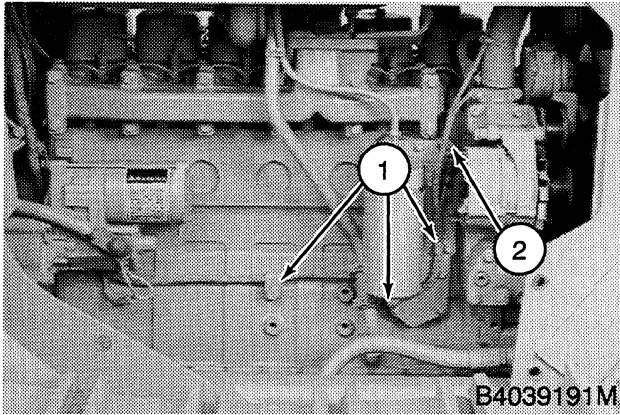

- 1. Cap Screws for Wiring Harness
- 2. Wires for Alternator

Install and tighten the cap screws and rubber washers that fasten the clamps for the wiring harness to the engine. Connect the wires to the alternator.

STEP 126

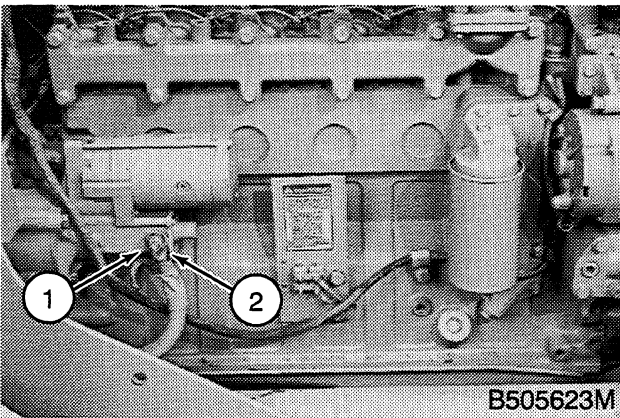

- 1. Battery Cable and Wire
- 2. Switch Terminal

Connect the wire to the switch terminal of the starter. Connect the wire and the battery cable to the battery cable terminal on the starter.

STEP 127

Remove the cap screws and rubber washers that fasten the clamps for the wiring harness to the engine.

STEP 128

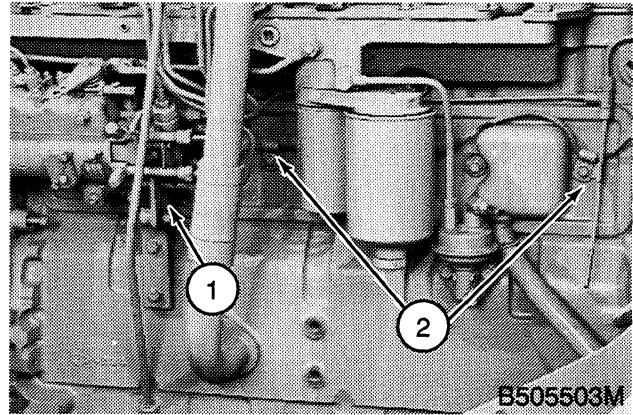

- 1. Wire for Fuel Injection Pump
- 2. Clamps

Put the wiring harness and clamps in position on the engine. Install the cap screws that fasten the clamps on the wiring harness to the engine. Connect the wire to the fuel injection pump.

STEP 129

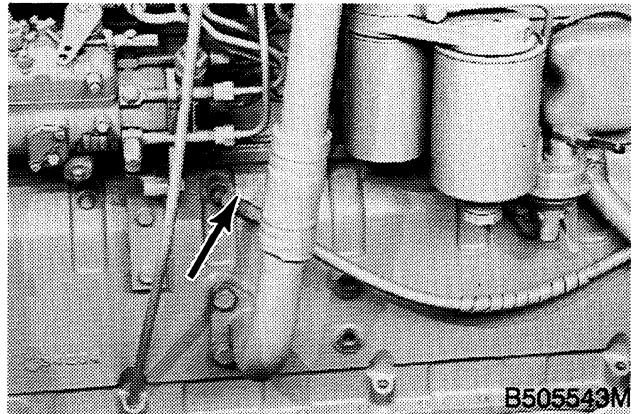

Connect the hose for the engine oil pressure gauge to the fitting in the engine.

<https://www.ebooklibonline.com>

Hello dear friend!

Thank you very much for reading.

Enter the link into your browser.

The full manual is available for immediate download.

<https://www.ebooklibonline.com>