

**821G  
921G  
Tier 2**  
Wheel Loader

**SERVICE MANUAL**

Part number 48083741

English

July 2018

© 2018 CNH Industrial Italia S.p.A. All Rights Reserved.

**CASE**  
CONSTRUCTION



## **SERVICE MANUAL**

**821G ZBAR - EH, NEW CAB TIER2  
921G ZBAR - EH, NEW CAB TIER2**

# Contents

---

## INTRODUCTION

Engine.....	10
[10.001] Engine and crankcase .....	10.1
[10.202] Air cleaners and lines .....	10.2
[10.400] Engine cooling system .....	10.3
[10.414] Fan and drive .....	10.4
[10.310] Aftercooler.....	10.5
[10.304] Engine lubrication system.....	10.6
Transmission.....	21
[21.113] Powershift transmission .....	21.1
[21.155] Powershift transmission internal components.....	21.2
[21.700] Torque converter .....	21.3
Four-Wheel Drive (4WD) system .....	23
[23.314] Drive shaft.....	23.1
Front axle system .....	25
[25.100] Powered front axle .....	25.1
[25.102] Front bevel gear set and differential .....	25.2
[25.108] Final drive hub, steering knuckles, and shafts .....	25.3
Rear axle system.....	27
[27.100] Powered rear axle.....	27.1
[27.106] Rear bevel gear set and differential .....	27.2
[27.120] Planetary and final drives .....	27.3
Brakes and controls .....	33
[33.202] Hydraulic service brakes .....	33.1
[33.110] Parking brake or parking lock .....	33.2
Hydraulic systems.....	35

**<https://www.ebooklibonline.com>**

Hello dear friend!

Thank you very much for reading.

Enter the link into your browser.

The full manual is available for immediate download.

**<https://www.ebooklibonline.com>**

[35.000] Hydraulic systems .....	35.1
[35.300] Reservoir, cooler, and filters .....	35.2
[35.106] Variable displacement pump .....	35.3
[35.359] Main control valve .....	35.4
[35.357] Pilot system .....	35.5
[35.204] Remote control valves .....	35.6
[35.752] Hydraulic fan drive cooling system .....	35.7
[35.701] Front loader arm hydraulic system .....	35.8
[35.723] Front loader bucket hydraulic system .....	35.9
[35.734] Tool quick coupler hydraulic system .....	35.10
<b>Frames and ballasting .....</b>	<b>39</b>
[39.100] Frame .....	39.1
<b>Steering .....</b>	<b>41</b>
[41.101] Steering control .....	41.1
[41.200] Hydraulic control components .....	41.2
[41.216] Cylinders .....	41.3
[41.910] Auxiliary steering .....	41.4
<b>Wheels .....</b>	<b>44</b>
[44.511] Front wheels .....	44.1
[44.520] Rear wheels .....	44.2
<b>Cab climate control .....</b>	<b>50</b>
[50.100] Heating .....	50.1
[50.200] Air conditioning .....	50.2
<b>Electrical systems .....</b>	<b>55</b>
[55.100] Harnesses and connectors .....	55.1
[55.301] Alternator .....	55.2
[55.302] Battery .....	55.3
[55.512] Cab controls .....	55.4

[55.050] Heating, Ventilation, and Air-Conditioning (HVAC) control system.....	55.5
[55.415] Loader arm and bucket control system .....	55.6
[55.530] Camera.....	55.7
[55.DTC] FAULT CODES.....	55.8
<b>Front loader and bucket.....</b>	<b>82</b>
[82.100] Arm.....	82.1
[82.300] Bucket.....	82.2
<b>Platform, cab, bodywork, and decals.....</b>	<b>90</b>
[90.150] Cab.....	90.1
[90.120] Mechanically-adjusted operator seat.....	90.2
[90.124] Pneumatically-adjusted operator seat.....	90.3
[90.105] Machine shields and guards .....	90.4



## **INTRODUCTION**

## Safety rules

### Personal safety





This is the safety alert symbol. It is used to alert you to potential personal injury hazards. Obey all safety messages that follow this symbol to avoid possible death or injury.

Throughout this manual you will find the signal words DANGER, WARNING, and CAUTION followed by special instructions. These precautions are intended for the personal safety of you and those working with you.

Read and understand all the safety messages in this manual before you operate or service the machine.

 DANGER indicates a hazardous situation that, if not avoided, will result in death or serious injury.

 WARNING indicates a hazardous situation that, if not avoided, could result in death or serious injury.

 CAUTION indicates a hazardous situation that, if not avoided, could result in minor or moderate injury.

**FAILURE TO FOLLOW DANGER, WARNING, AND CAUTION MESSAGES COULD RESULT IN DEATH OR SERIOUS INJURY.**

### Machine safety

**NOTICE:** Notice indicates a situation that, if not avoided, could result in machine or property damage.

Throughout this manual you will find the signal word Notice followed by special instructions to prevent machine or property damage. The word Notice is used to address practices not related to personal safety.

### Information

**NOTE:** Note indicates additional information that clarifies steps, procedures, or other information in this manual.

Throughout this manual you will find the word Note followed by additional information about a step, procedure, or other information in the manual. The word Note is not intended to address personal safety or property damage.

## Personal safety

Carefully read this Manual before proceeding with maintenance, repairs, refuelling or other machine operations.

Repairs have to be carried out only by authorized and instructed staff; specific precautions have to be taken when grinding, welding or when using mallets or heavy hammers.

Non-authorized persons are not allowed to repair or carry out maintenance on this machine. Do not carry out any work on the equipment without prior authorization.

Ask your employer about the safety instructions in force and safety equipment.

Nobody should be allowed in the cab during machine maintenance unless he is a qualified operator helping with the maintenance work.

If it is necessary to move the equipment to carry out repairs or maintenance, do not lift or lower the equipment from any other position than the operator's seat.

Never carry out any operation on the machine when the engine is running, except when specifically indicated.

Stop the engine and ensure that all pressure is relieved from hydraulic circuits before removing caps, covers, valves, etc.

All repair and maintenance operations should be carried out with the greatest care and attention.

Service stairs and platforms used in a workshop or in the field should be built in compliance with the safety rules in force.

Any functional disorders, especially those affecting the safety of the machine, should therefore be rectified immediately.

### **⚠ DANGER**

**Unexpected movement!**

**Make sure parking brake is applied. Secure machine with wheel chocks.**

**Failure to comply will result in death or serious injury.**

D0013A

Before performing any work on the machine, attach a maintenance in progress tag. This tag can be applied on the left-hand control lever, safety lever or cab door.

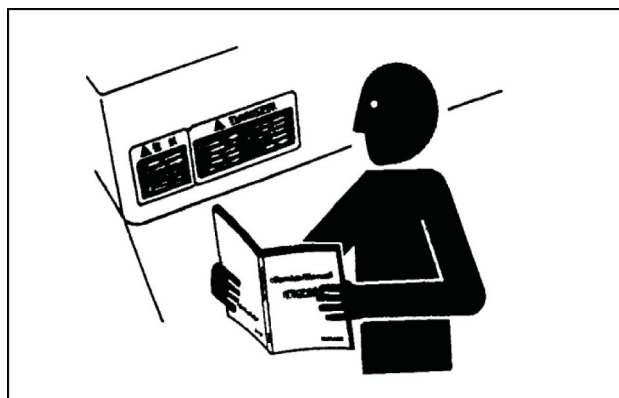

TULI12WEX2004AA 1

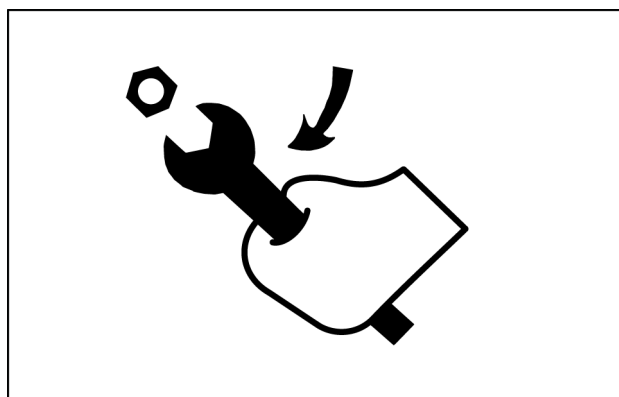

TULI12WEX2005AA 2

## Emergency

Be prepared for emergencies. Always keep a fire extinguisher and first aid kit readily available. Ensure that the fire extinguisher is serviced in accordance with the manufacturer's instructions.

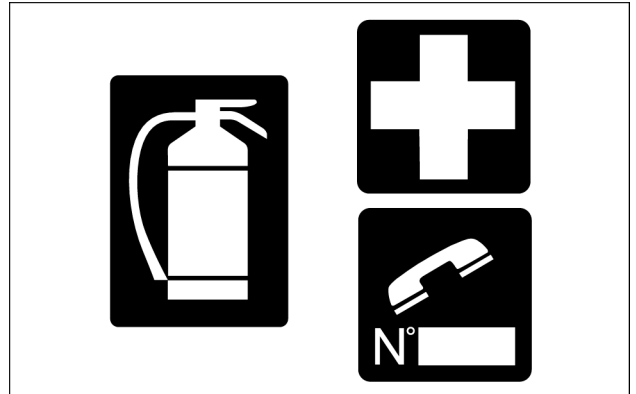

SMIL12WEX0174AA 3

## Equipment

Wear close fitting clothing and safety equipment appropriate for the job:

- Safety helmet
- Safety shoes
- Heavy gloves
- Reflective clothing
- Wet weather clothing

If working conditions require, the following personal safety equipment should be on hand:

- Respirators (or dust proof masks)
- Ear plugs or acoustic ears protections
- Goggles with lateral shield or masks for eye protection

Do not wear rings, wristwatches, jewelry, unbuttoned or flapping clothing such as ties, torn clothes, scarves, open jackets or shirts with open zips which could get caught into moving parts.

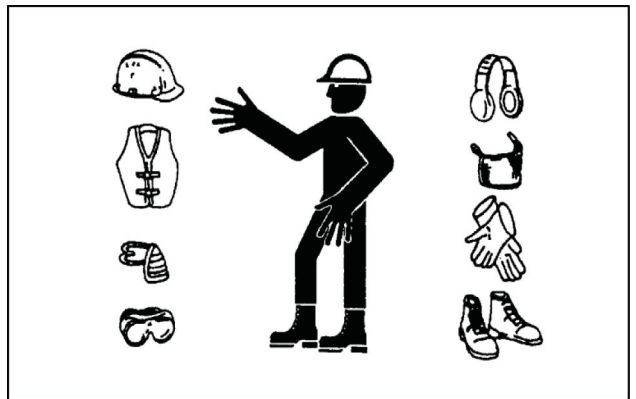

TULI12WEX2008AA 4

## Engine - Radiator

Never leave the engine running in enclosed spaces without proper ventilation which is able to evacuate toxic exhaust gases- Keep the exhaust manifold and tube free from combustible materials.

Do not refuel with the engine running, especially if hot, as this increases fire hazard in case of fuel spillage.

Never attempt to check or adjust the belts when the engine is running.

Never lubricate the machine with the engine running.

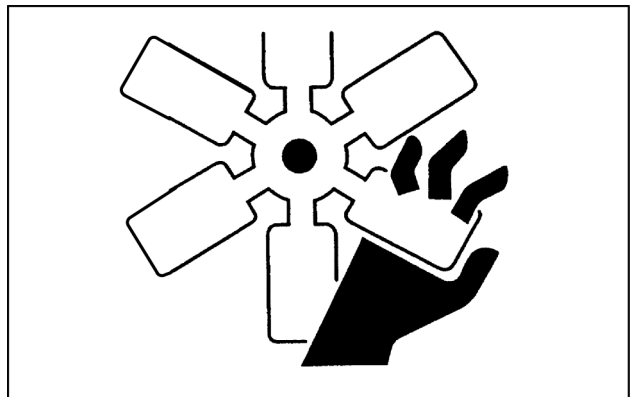

TULI12WEX2009AA 5

## Product identification

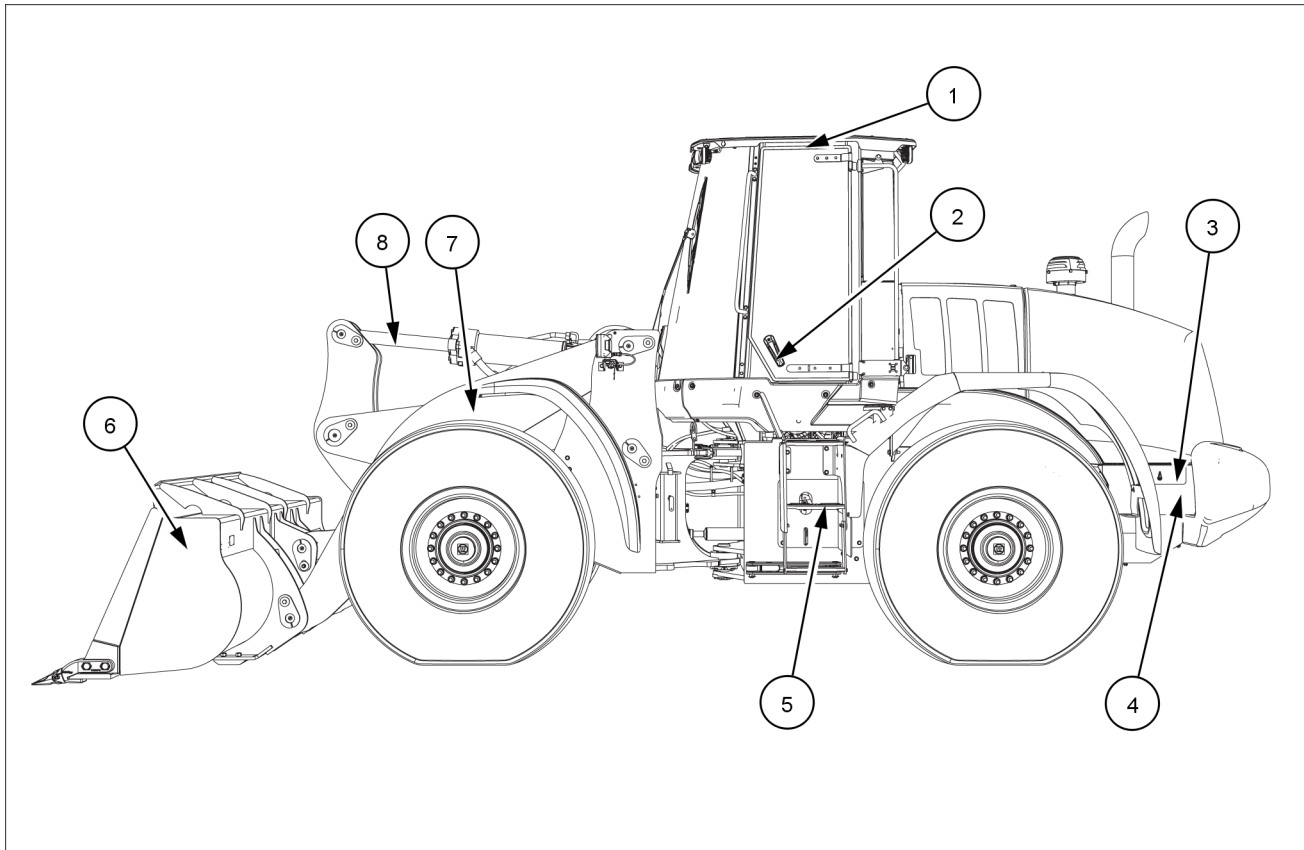

LEIL16WHL2487FA 1

- |   |                           |
|---|---------------------------|
| 1. Roll Over Protection System (ROPS) cab                 | 5. Steps                  |
| 2. Cab door handle  | 6. Bucket (Z-bar version) |
| 3. Timed disconnect switch and optional battery jump post | 7. Loader lift arms       |
| 4. Battery access   | 8. Bucket cylinder        |

## INTRODUCTION

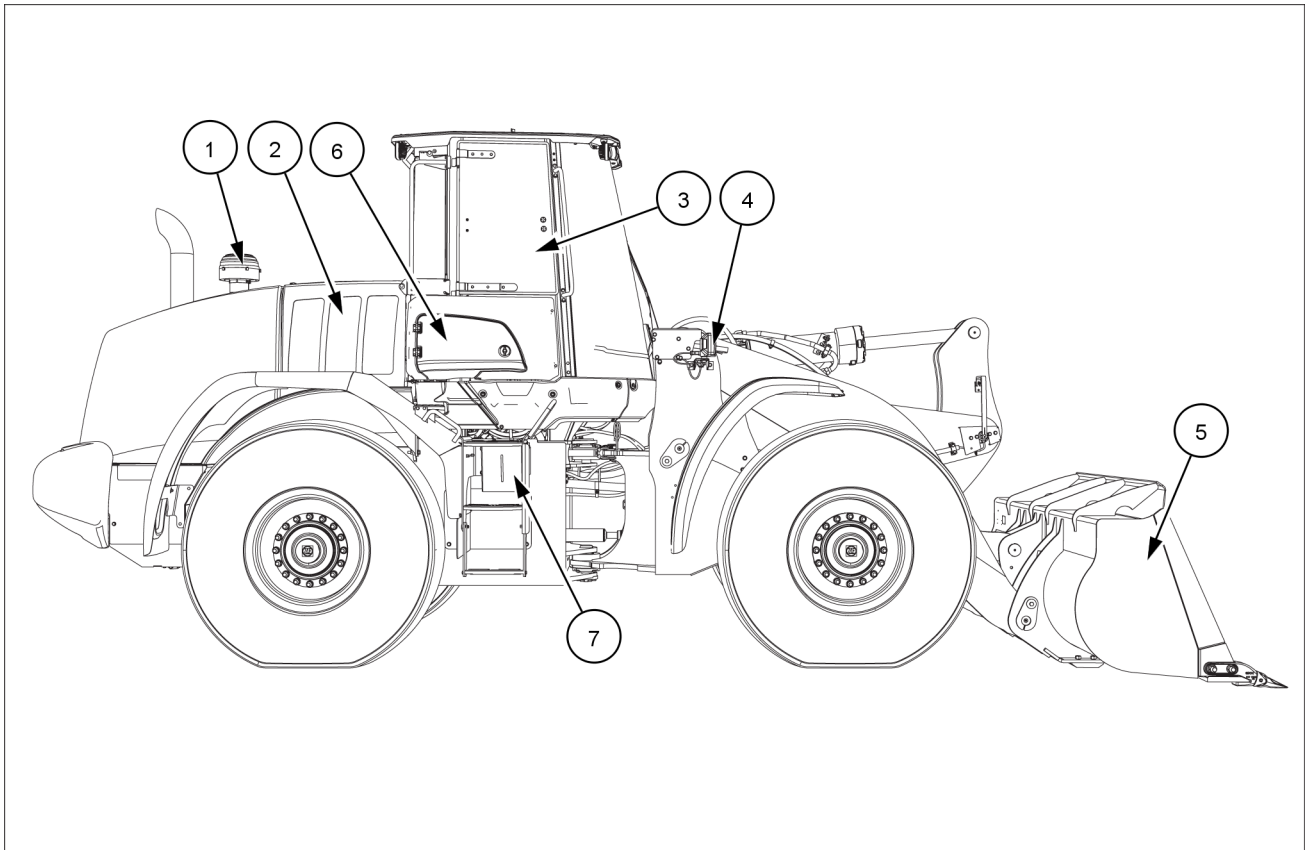

LEIL16WHL2486FA 2

- |                         |                                |
|-------------------------|--------------------------------|
| 1. Pre-cleaner          | 5. Bucket (Z-bar version)      |
| 2. Sliding access panel | 6. Cab air filter door         |
| 3. Cab side window      | 7. Windshield washer reservoir |
| 4. Driving lights       |                                |



# **SERVICE MANUAL**

## **Engine**

**821G ZBAR - EH, NEW CAB TIER2  
921G ZBAR - EH, NEW CAB TIER2**

## Engine - General specification

821G ZBAR - EH, NEW CAB TIER2 | ANZ --- APAC --- LA --- MEA

Engine with 4 Speed Transmission	
A. Low idle	<b>870 RPM to 930 RPM</b>
Alternate low idle	<b>670 RPM to 730 RPM</b>
Alternate accelerated idle	<b>1270 RPM to 1330 RPM</b>
Working idle (setting from factory)	<b>920 RPM to 980 RPM</b>
B. Maximum No Load RPM	<b>2065 RPM to 2185 RPM</b>
C. Converter Stall	<b>1775 RPM to 1975 RPM</b>
D. Hydraulic Stall	<b>1915 RPM to 2115 RPM</b>
E. Converter & Hydraulic Stall	<b>1410 RPM to 1610 RPM</b>
Temperature of the torque converter oil	<b>82 – 104 °C (180 – 219 °F)</b>
Temperature of the hydraulic oil	<b>54 – 57 °C (129 – 135 °F)</b>

Engine with 5 Speed Transmission	
A. Low idle	<b>870 RPM to 930 RPM</b>
Alternate low idle	<b>670 RPM to 730 RPM</b>
Alternate accelerated idle	<b>1270 RPM to 1330 RPM</b>
Working idle (setting from factory)	<b>920 RPM to 980 RPM</b>
B. Maximum No Load RPM	<b>2065 RPM to 2185 RPM</b>
C. Converter Stall	<b>1832 RPM to 2032 RPM</b>
D. Hydraulic Stall	<b>1920 RPM to 2120 RPM</b>
E. Converter & Hydraulic Stall	<b>1450 RPM to 1650 RPM</b>
Temperature of the torque converter oil	<b>82 – 104 °C (180 – 219 °F)</b>
Temperature of the hydraulic oil	<b>54 – 57 °C (129 – 135 °F)</b>

**NOTE:** hydraulic Stall and Converter and Hydraulic Stall RPM values are read while the lift arms are rising with the bucket held rolled back and the engine at Wide Open Throttle (WOT) in max power mode with transmission in manual mode and in 3rd gear.

## Engine - General specification

921G ZBAR - EH, NEW CAB TIER2 | ANZ --- APAC --- LA --- MEA

Engine with 4 Speed Transmission	
A. Low idle	<b>870 RPM to 930 RPM</b>
Alternate low idle	<b>670 RPM to 730 RPM</b>
Alternate accelerated idle	<b>1270 RPM to 1330 RPM</b>
Working idle (setting from factory)	<b>970 RPM to 1030 RPM</b>
B. Maximum No Load RPM	<b>2115 RPM to 2200 RPM</b>
C. Converter Stall	<b>1865 RPM to 2065 RPM</b>
D. Hydraulic Stall	<b>1905 RPM to 2105 RPM</b>
E. Converter & Hydraulic Stall	<b>1450 RPM to 1650 RPM</b>
Temperature of the torque converter oil	<b>82 – 104 °C (180 – 219 °F)</b>
Temperature of the hydraulic oil	<b>54 – 57 °C (129 – 135 °F)</b>

Engine with 5 Speed Transmission	
A. Low idle	<b>870 RPM to 930 RPM</b>
Alternate low idle	<b>670 RPM to 730 RPM</b>
Alternate accelerated idle	<b>1270 RPM to 1330 RPM</b>
Working idle (setting from factory)	<b>970 RPM to 1030 RPM</b>
B. Maximum No Load RPM	<b>2115 RPM to 2200 RPM</b>
C. Converter Stall	<b>1867 RPM to 2067 RPM</b>
D. Hydraulic Stall	<b>1957 RPM to 2157 RPM</b>
E. Converter & Hydraulic Stall	<b>1450 RPM to 1650 RPM</b>
Temperature of the torque converter oil	<b>82 – 104 °C (180 – 219 °F)</b>

---

Temperature of the hydraulic oil	54 – 57 °C (129 – 135 °F)
----------------------------------	---------------------------

---

**NOTE:** *hydraulic Stall and Converter and Hydraulic Stall RPM values are read while the lift arms are rising with the bucket held rolled back and the engine at Wide Open Throttle (WOT) in max power mode with transmission in manual mode and in 3rd gear.*

## Engine - Remove

1. Park the machine on a level surface and lower the bucket to the ground. Put the articulation lock in LOCKED position and stop the engine.

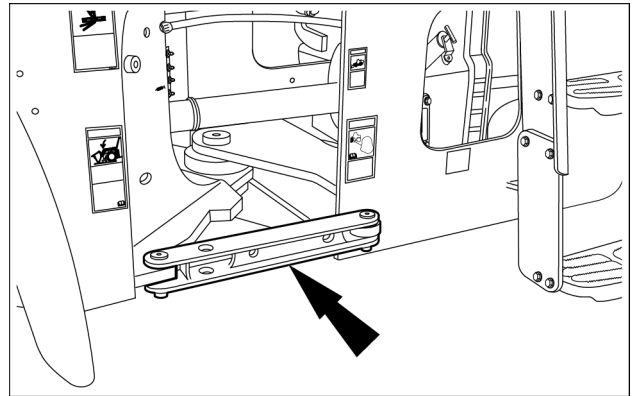

LEIL16WHL0048AB 1

2. Actuate the brake pedal several times to discharge the brake accumulators.

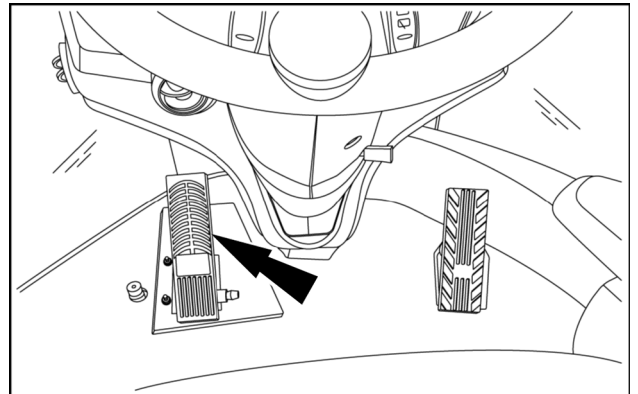

LEIL15WHL0564AA 2

3. Put the key switch to ON position. Press the hydraulic functions lock-out button to unlock all hydraulic functions. Move the control lever(s) back and forth at least 30 times to release any pressure from the hydraulic circuit. Put the key switch to OFF position.

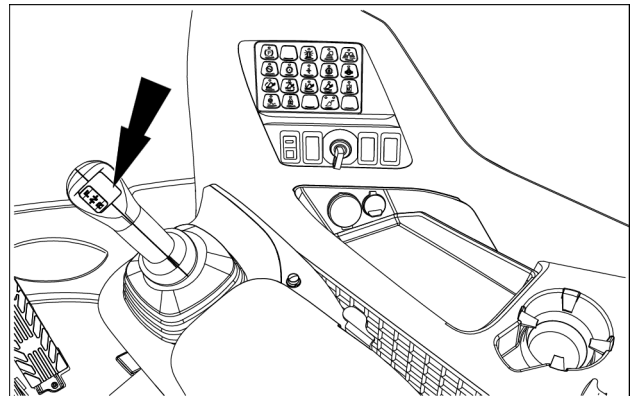

LEIL16WHL1286AA 3

4. Raise the grill located above the cooler box just behind the cab. Then slowly loosen the hydraulic reservoir filler cap to release pressure in the reservoir.

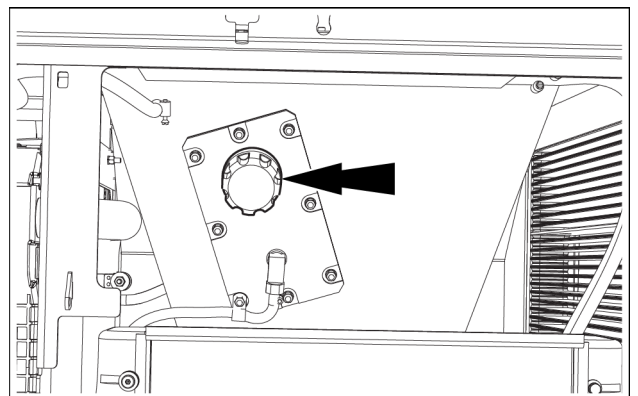

LEIL17WHL0028AB 4

5. Locate the timed disconnect switch and hood raise switch in the battery box. Raise the engine hood and put the timed disconnect switch to OFF position.

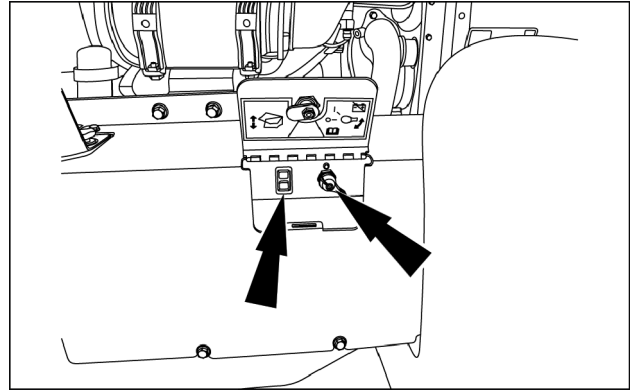

RCPH10WHL106AAH 5

6. Unhook the rubber T-handle (1) and raise the upper panel (2). Make sure that the security levers are blocked.

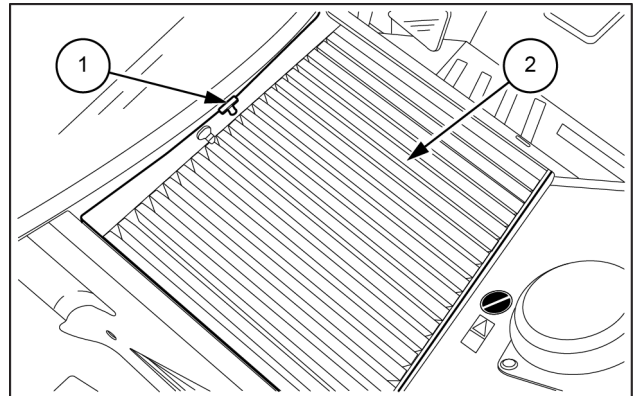

LEIL13WHL0137AB 6

7. Raise the right-hand and left-hand side panels (1). Then remove the thumb screws (2) and inner fender panels (3).

**NOTE:** right-hand side of the machine is shown. The operation is similar for the left-hand side.

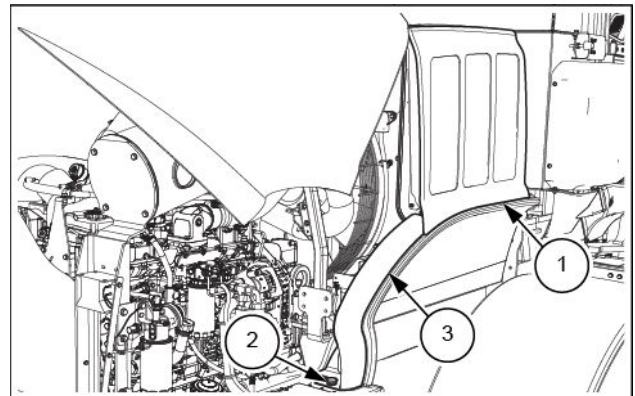

LEIL17WHL0027AB 7

8. Place a suitable container below the radiator drain plug, remove the radiator cap and the radiator drain plug to drain the engine coolant. Then reinstall the radiator drain plug and the radiator cap after coolant has drained.

**NOTE:** see machine specifications for cooling system volume.

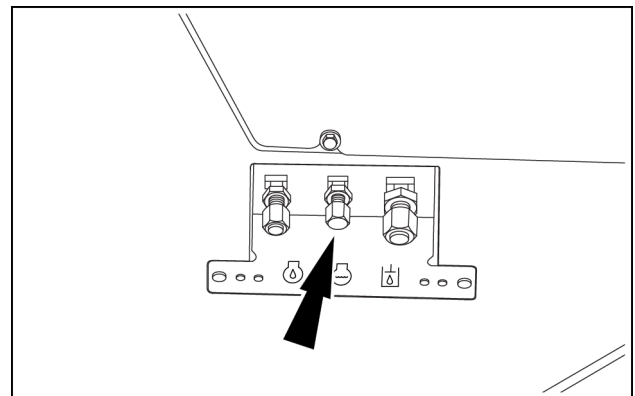

LEIL16WHL0198AA 8

- Place a suitable container below the engine oil drain plug. Remove the engine oil drain plug and drain oil into container. Then reinstall the engine oil drain plug.

**NOTE:** see machine specifications for engine oil sump volume.

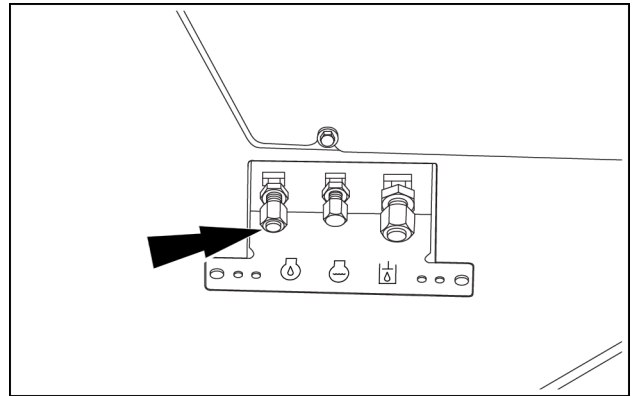

LEIL16WHL0198AA 9

- Remove the drain hose (1) from the frame bracket (2).

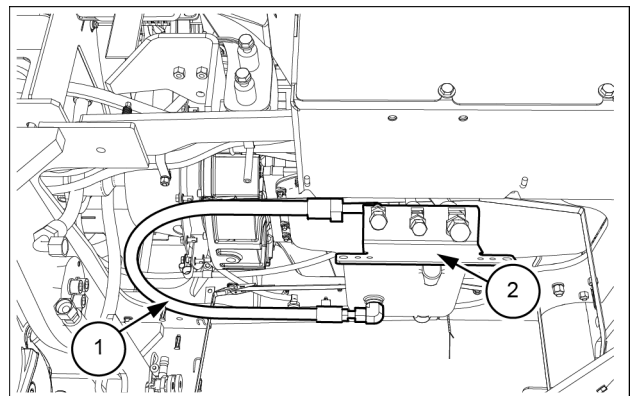

LEIL16WHL1250AB 10

- Remove the engine hood (refer to **Engine hood - Remove (90.105)**).

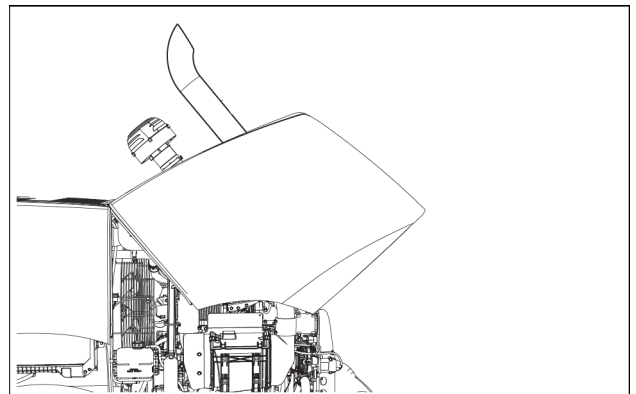

LEIL17WHL0026AB 11

- Remove the overflow tank of the engine coolant.

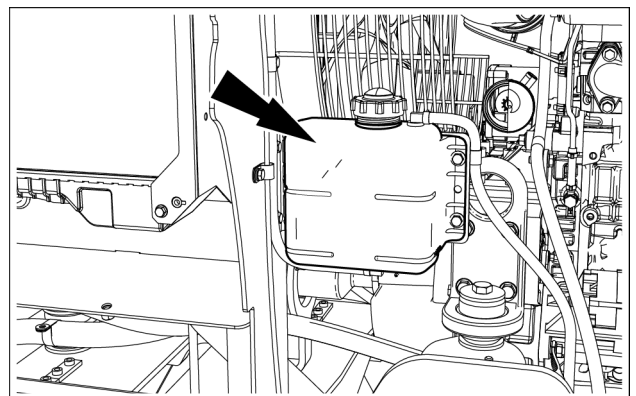

LEIL16WHL0574AB 12

13. Remove the support bracket of the engine coolant overflow tank.

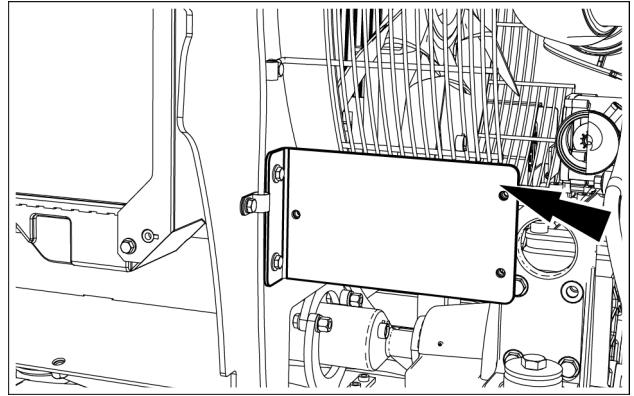

LEIL16WHL0575AB 13

14. Remove the cooling fan guard.

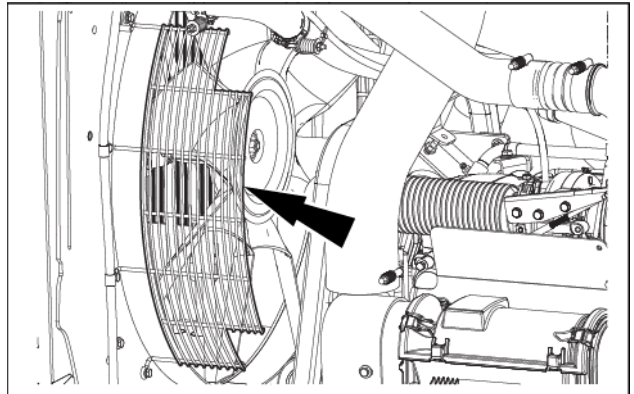

LEIL17WHL0137AB 14

15. Loosen the four bolts to remove the engine guard (1).

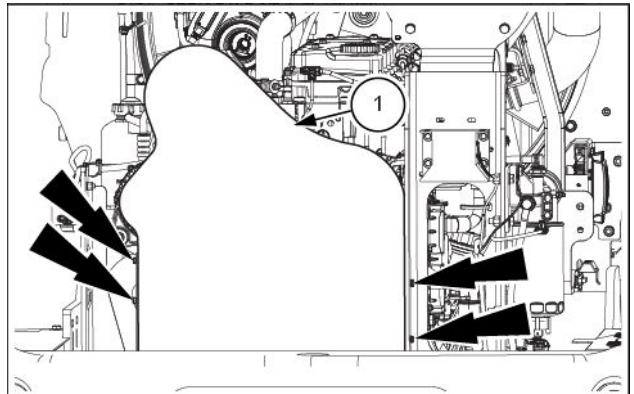

LEIL17WHL0118AB 15

16. Disconnect the crankcase vent hose from the engine.

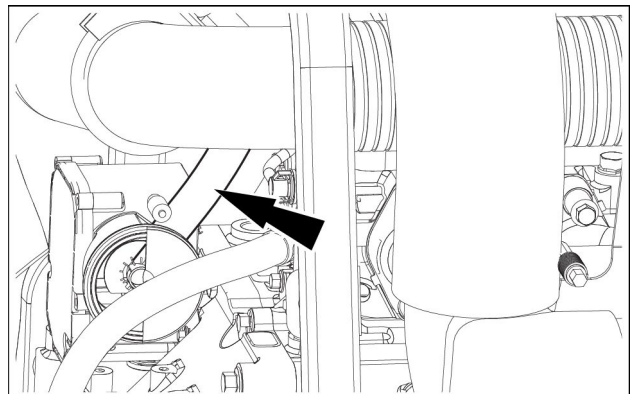

LEIL17WHL0136AB 16

17. Remove the clamps **(3)** that secure the crankcase vent hose **(2)** to the brackets **(1)**. Remove the brackets **(1)** from the engine.

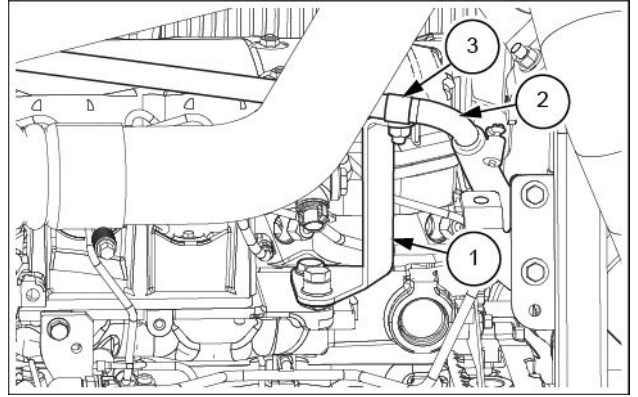

LEIL17WHL0133AB 17

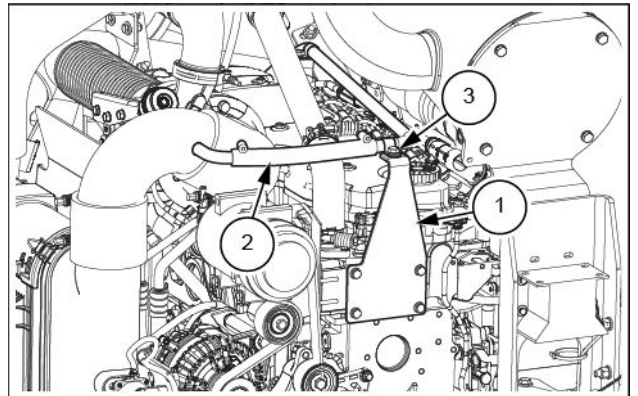

LEIL17WHL0119AB 18

18. Remove the clamp to disconnect the air cleaner from the engine.

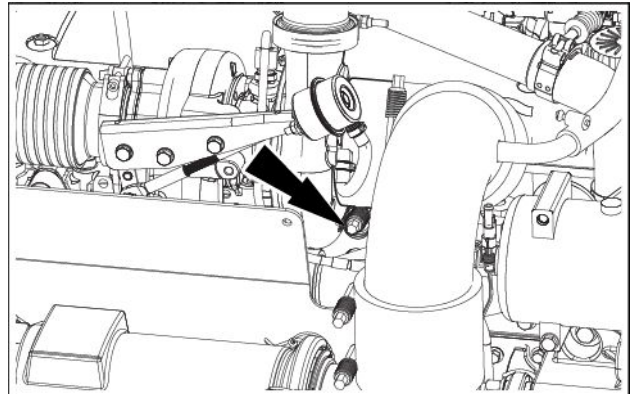

LEIL17WHL0135AB 19

19. Tag and disconnect the AFS2 connector **(4)** from the air cleaner **(3)**. Remove the hardware **(1)** to unfix the air cleaner support bracket **(2)** from the rear chassis. Remove the air cleaner assembly from the machine.

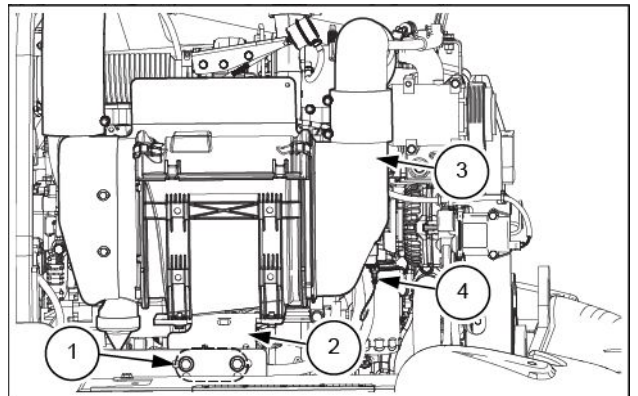

LEIL17WHL0120AB 20

20. Remove the drive belt from the engine.

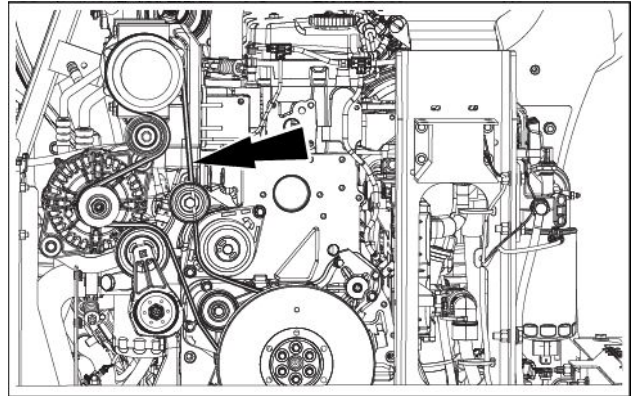

LEIL17WHL0117AB 21

21. Tag and disconnect the ACT connector from the air-conditioning compressor clutch and ALT\_5, ALT\_B connectors from the alternator. Remove the alternator (2) and air-conditioning compressor (1).

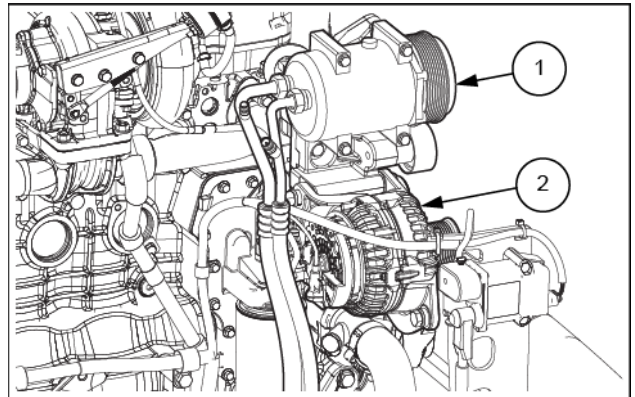

LEIL17WHL0116AB 22

22. Remove the clamp (2) that secures the heater supply hose (1) to the flywheel cover. Tag and disconnect the heater supply hose (1) from the engine.

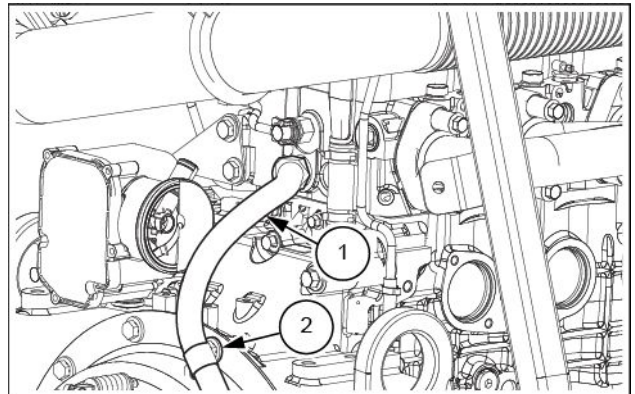

LEIL17WHL0115AB 23

23. Remove the clamps that secure the cables to the engine.

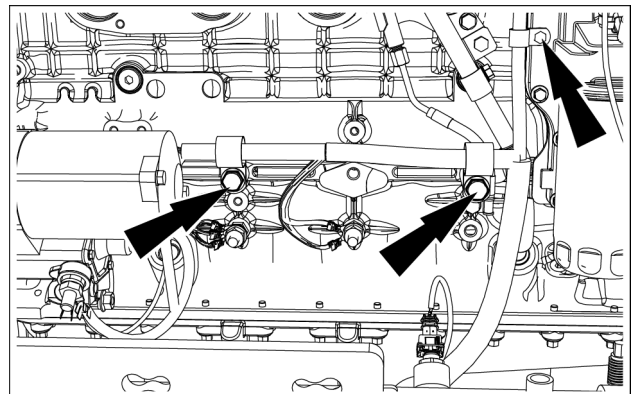

LEIL16WHL0570AB 24

24. Tag and disconnect the ST, CPWR and battery positive cables **(1)** from the engine starter.  
 Tag and disconnect the negative battery cable **(2)**, ground strap **(3)** and XM1C cable **(4)** from the engine starter.  
 Tag and disconnect the GND\_ENG1, GND\_ENG3, GND\_ENG4 cables **(5)** and GND\_CENG1, GND\_CENG2 cables **(6)** from the engine.

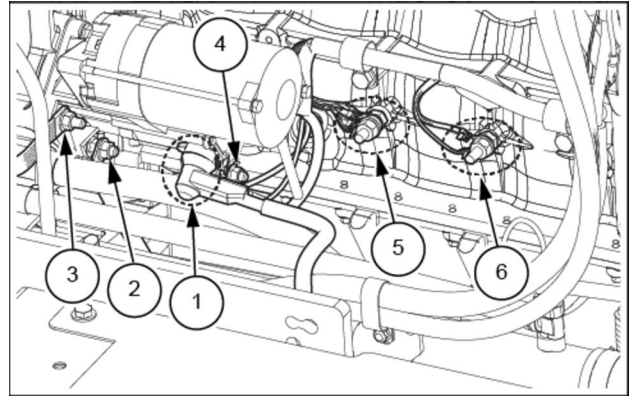

LEIL17WHL0114AB 25

25. Tag and disconnect the breather line (hose and venting check valve) from the engine.

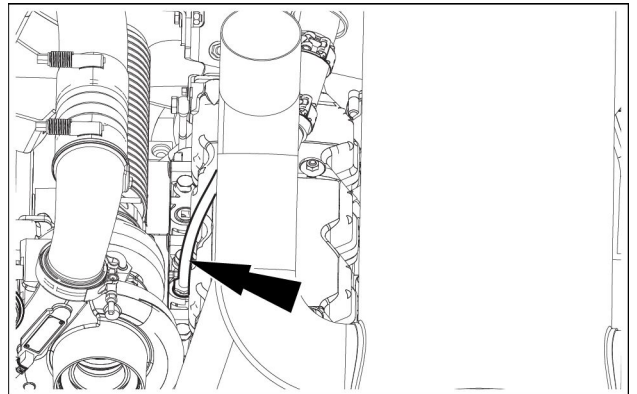

LEIL17WHL0094AB 26

26. Remove the U-bolt clamp to unfix the top cooling line from the muffler support structure.

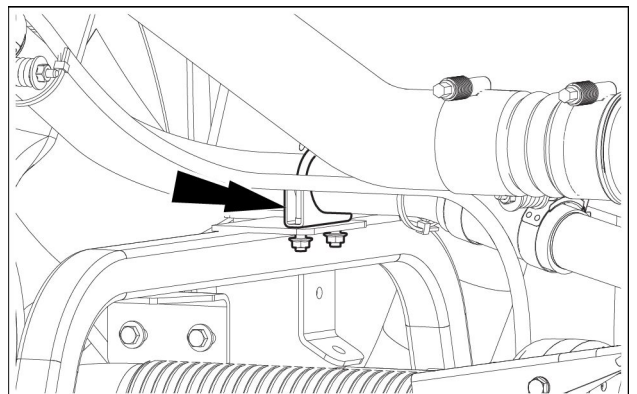

LEIL17WHL0095AB 27

27. Remove the clamps **(2)** to disconnect the top cooling line **(1)** from the elbow hose and engine. Tag the hose.

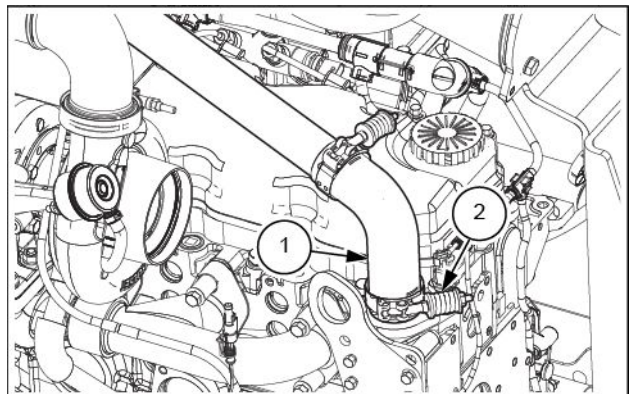

LEIL17WHL0093AB 28

28. Remove the clamp **(2)** to disconnect the bottom engine coolant line **(1)** from the engine. Tag the hose.

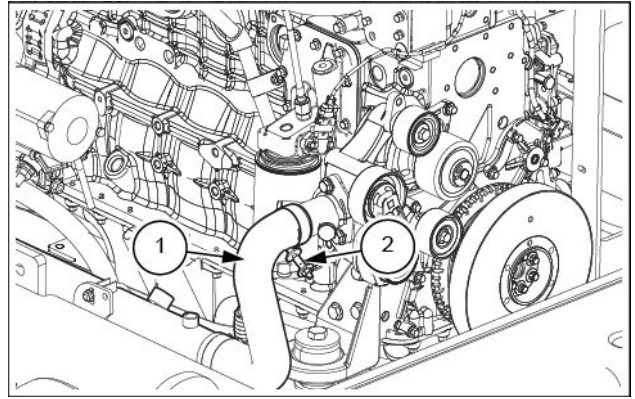

LEIL17WHL0092AB 29

29. Remove the clamps **(2)** to disconnect the turbo outlet air cooling line **(1)** from the charge air cooler and engine. Tag the hose.

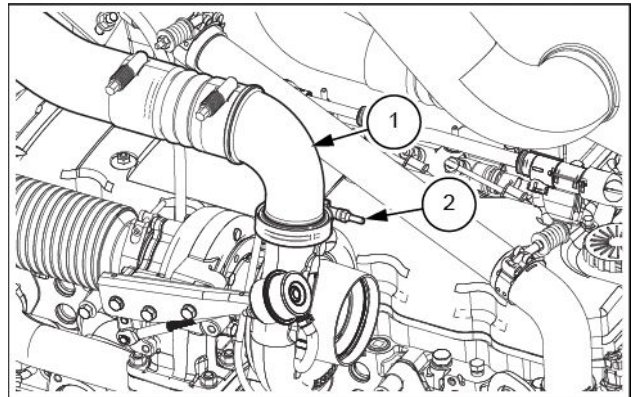

LEIL17WHL0091AB 30

30. Remove the clamps **(2)** to disconnect the air intake cooling line **(1)** from the charge air cooler and engine. Tag the hose.

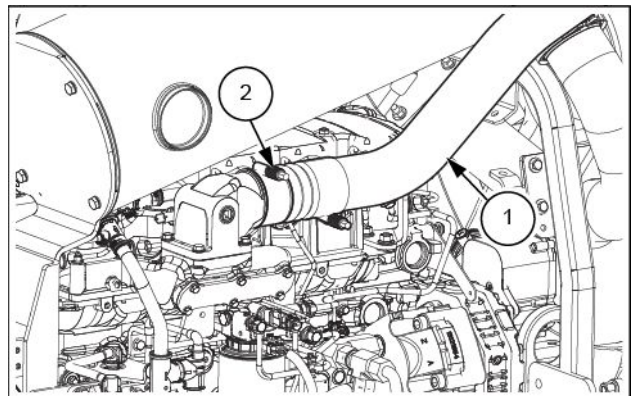

LEIL17WHL0090AB 31

31. Tag and disconnect the fuel pre-filter to engine hose **(8)** from the engine.
32. Remove the clamp **(7)** that secures the fuel tank suction hose to the rear muffler support.
33. Tag and disconnect the WIF connector **(9)** and WSH connector **(6)** from the fuel pre-filter **(4)**.
34. Tag and disconnect the fuel pre-filter **(4)** from the support bracket.  
Tag the GRD\_WIF wire **(5)**.
35. Remove the fuel pre-filter support bracket **(3)** from the rear muffler support.
36. Remove the cable ties that secure the wires to the rear muffler support.  
Tag and disconnect the wires **(2)** from the alarm back-up **(1)**.  
Remove the alarm back-up **(1)** from the rear muffler support.
37. Remove the clamp **(2)** to disconnect the end of the exhaust system pipe **(1)** from the engine.

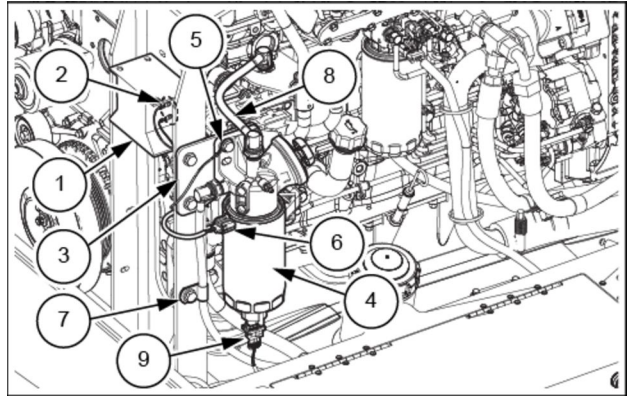

LEIL17WHL0055AB 32

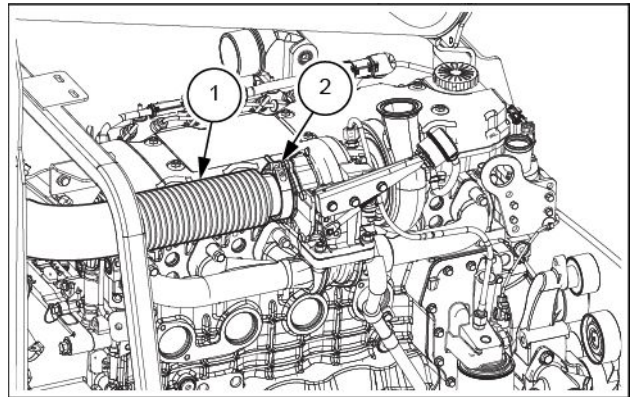

LEIL17WHL0054AB 33

38. Attach a suitable lifting device to the exhaust system assembly (1) (including muffler, pipe, support brackets).

Remove the hardware at the noted six locations to unfix the exhaust system assembly (1) from the rear chassis.

Lift and remove the exhaust system assembly (1) from the machine.

**NOTE:** be sure all wire harness connections and hoses are out of the way.

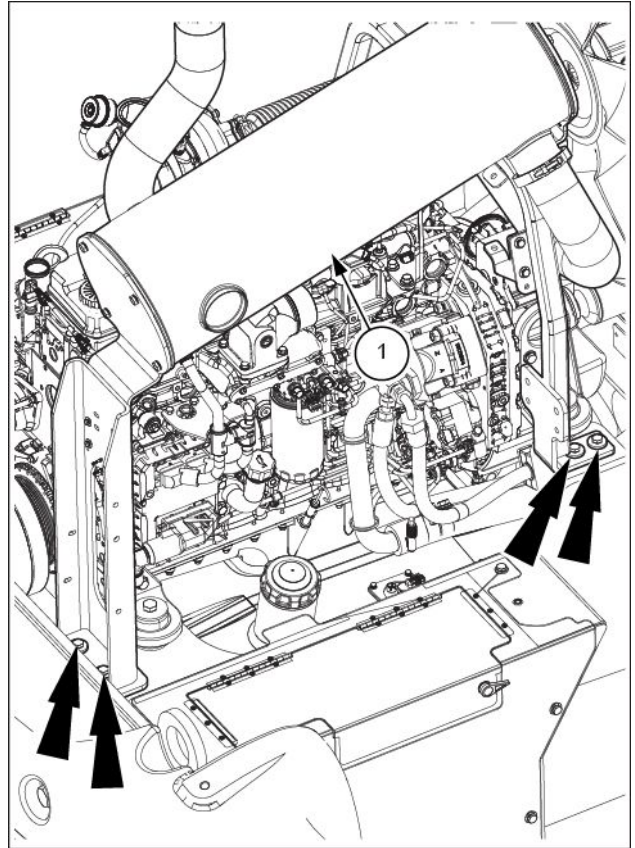

LEIL17WHL0053BB 34

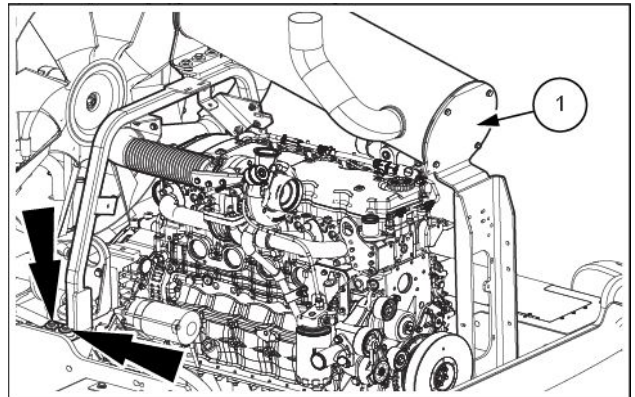

LEIL17WHL0051AB 35

39. Remove the nuts (3) and studs (2) to disconnect the engine starter (1) from the engine.

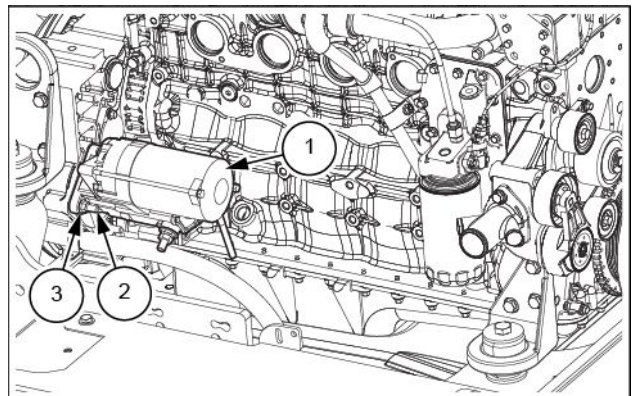

LEIL17WHL0052AB 36

40. Tag and disconnect the EDC7 connector from the Engine Controller Unit (ECU).

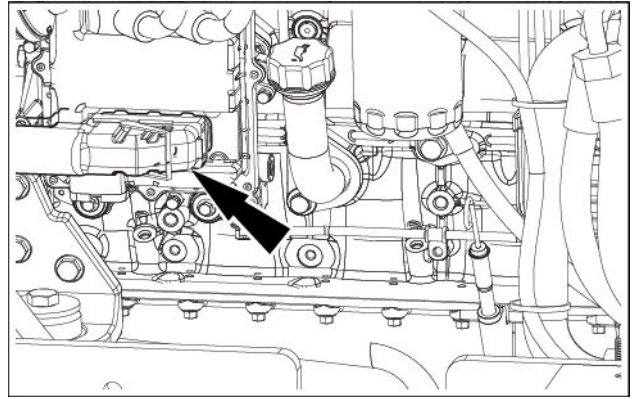

LEIL17WHL0050AB 37

41. Tag and disconnect the FFH connector from the fuel filter.

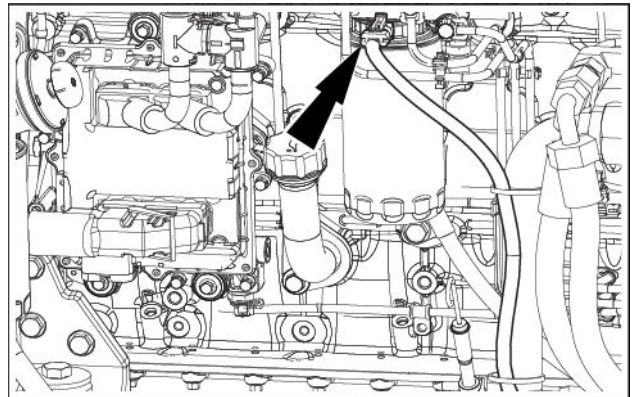

LEIL17WHL0049AB 38

42. Remove the clamp **(1)** to release the fuel return hose **(2)**. Tag and disconnect the fuel return hose **(2)** from the fuel filter.

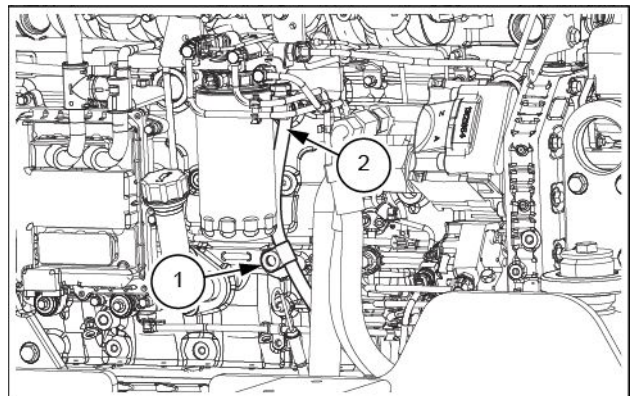

LEIL17WHL0046AB 39

43. At the noted location remove the clamp to release the fuel tank suction hose.

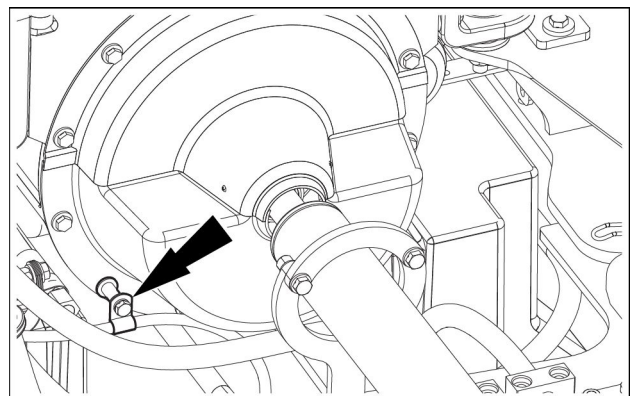

LEIL17WHL0086AB 40

44. Remove the upper and lower drive shaft dust covers.

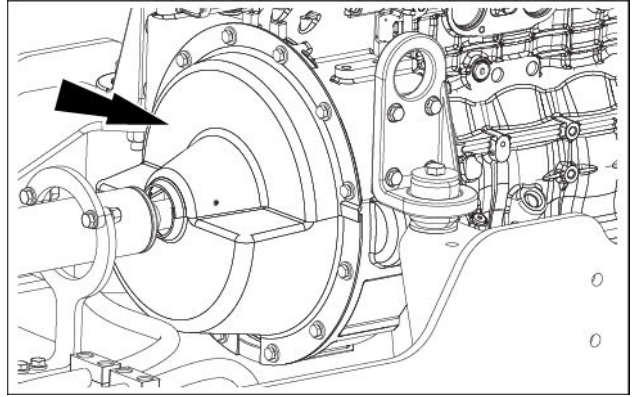

LEIL17WHL0048AB 41

45. Remove the bolts to disengage the drive shaft from the engine coupling.

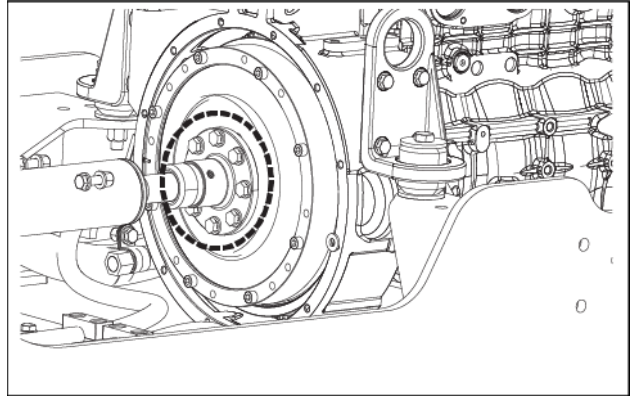

LEIL17WHL0047AB 42

46. Connect a vacuum pump to the hydraulic reservoir and turn it on. Tag and disconnect the suction hose (2), pressure hose (4) and attenuator hose (3) from the brake pump (1). Remove the brake pump (1) (refer to **Brake pump - Remove (33.202)**). Turn off and disconnect the vacuum pump from the hydraulic reservoir.

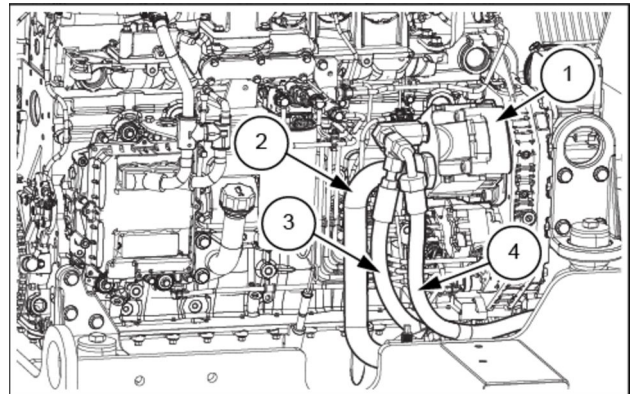

LEIL17WHL0045AB 43

47. Connect a suitable lifting equipment to the engine mounts **(1)**. Take up all slack in lifting equipment. Remove the engine mount bolts **(2)**.
48. Slowly raise the engine from the rear chassis. Make sure all wire harness connections and hoses have been disconnected and are clear of the engine. Guide the oil drain hose from the frame as the engine is lifted. Remove the engine from machine.

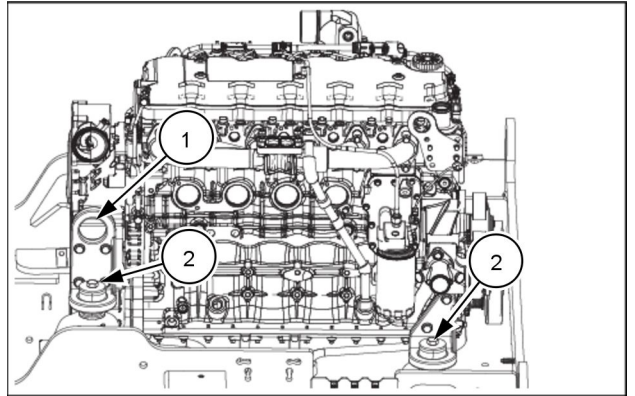

LEIL17WHL0034AA 44

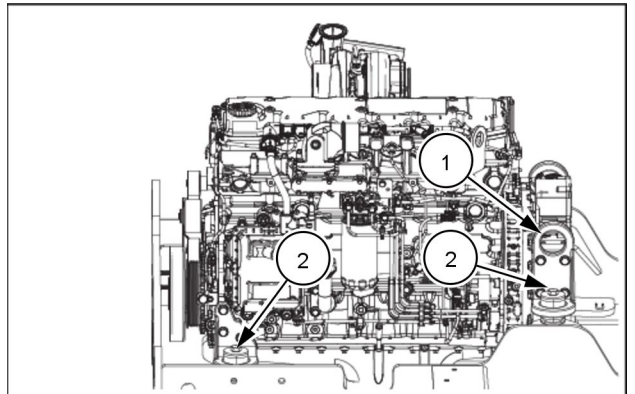

LEIL17WHL0035AA 45

## Engine - Install

### **⚠ WARNING**

**Hot liquid under pressure!**

**Never remove the filler cap or the recovery tank cap while the engine is running or the coolant is hot. Let the system cool. Turn the filler cap to the first notch and allow any pressure to escape, and then remove the filler cap. Loosen the recovery tank cap slowly to allow any pressure to escape. Failure to comply could result in death or serious injury.**

W0296A

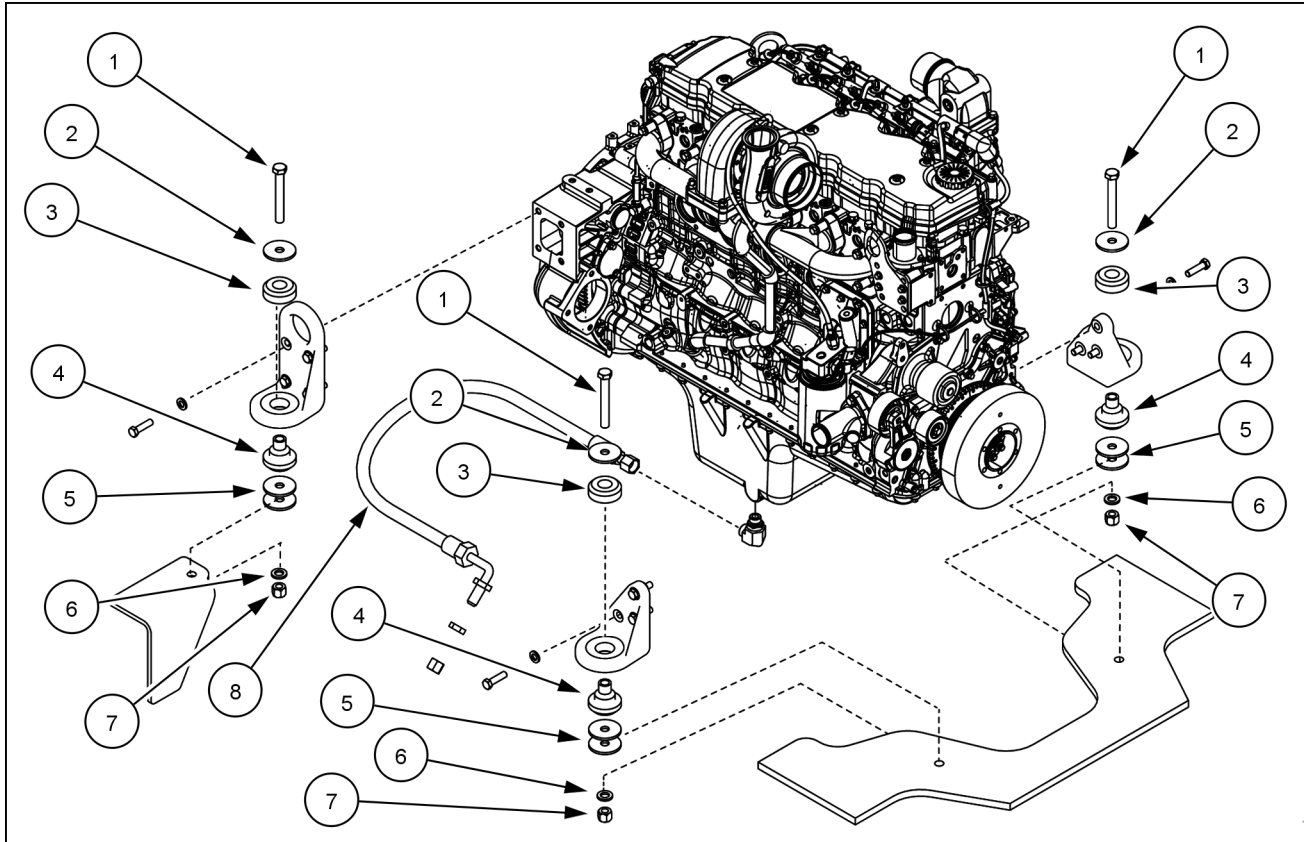

RAIL12WEL0130FA 1

- |                      |                          |
|----------------------|--------------------------|
| 1. Engine mount bolt | 5. Washers               |
| 2. Washer            | 6. Washer                |
| 3. Upper isolator    | 7. Nut                   |
| 4. Lower isolator    | 8. Remote oil drain hose |

1. Inspect the engine mounts. If the engine rubber isolators require replacement, remove and discard the upper isolators (3) and lower isolators (4). Install new upper isolators (3) and new lower isolators (4).

2. Attach a suitable lifting device to the engine mounts (1) and slowly move the engine into position over the rear chassis. Make sure all harness connections and hoses are out of the way or positioned correctly for reconnecting, before lowering the engine.
3. Fix the engine to the rear chassis. Torque the engine mount bolts (2) to **244 – 298 N·m (180 – 220 lb ft)**.
4. Disconnect the lifting equipment from the engine mounts.

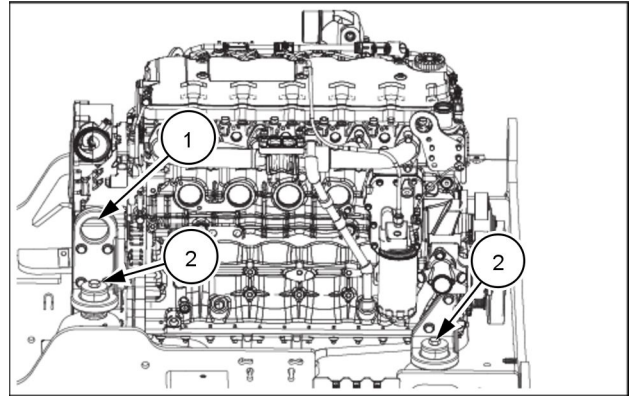

LEIL17WHL0034AA 2

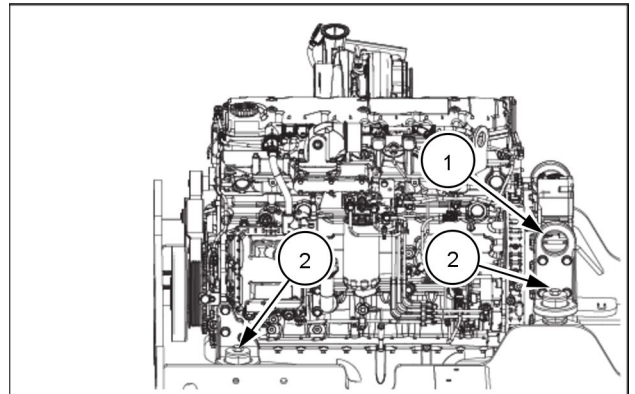

LEIL17WHL0035AA 3

5. Connect a vacuum pump to the hydraulic reservoir and turn it on. Install the brake pump (1). Connect the suction hose (2), pressure hose (4) and attenuator hose (3) to the brake pump following the tags applied during removal (refer to **Brake pump - Install (33.202)**). Turn off and disconnect the vacuum pump from the hydraulic reservoir.

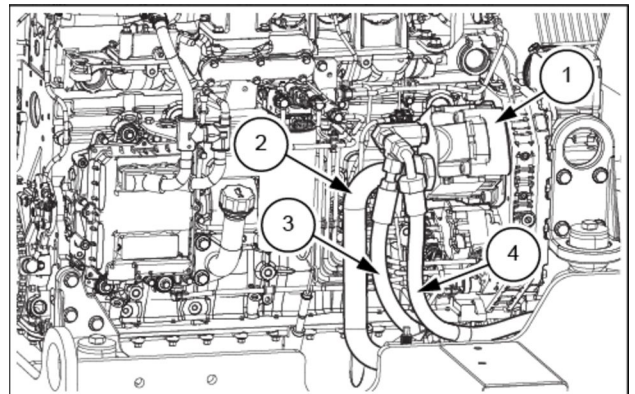

LEIL17WHL0045AB 4

6. Connect the engine oil drain hose (1) to the frame bracket (2).

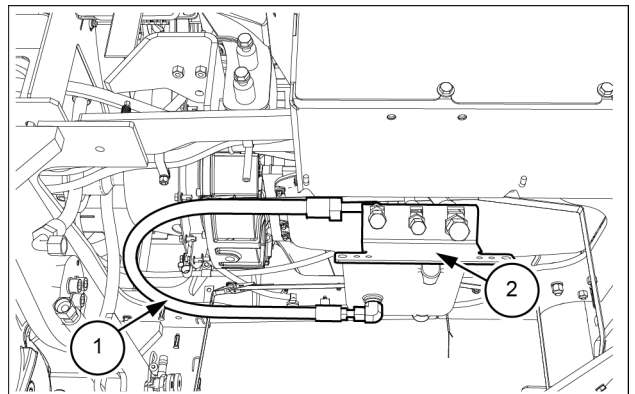

LEIL16WHL1250AB 5

7. Position the drive shaft on the engine coupling. Install the six bolts (4-speed transmission) or eight bolts (5-speed transmission) to secure the drive shaft to the engine coupling.

**NOTE:** the figure shows the machine with 5-speed transmission.

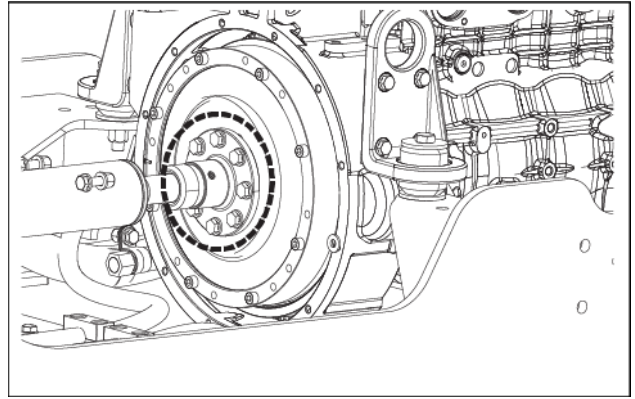

LEIL17WHL0047AB 6

8. Tighten to **86 – 94 N·m (63 – 69 lb ft)** (821G, 4-speed transmission).  
Tighten to **85 – 94 N·m (63 – 69 lb ft)** (621G, 721G, 921G, 4-speed transmission and 721G 5-speed transmission).  
Follow the bolt installation pattern in figure.

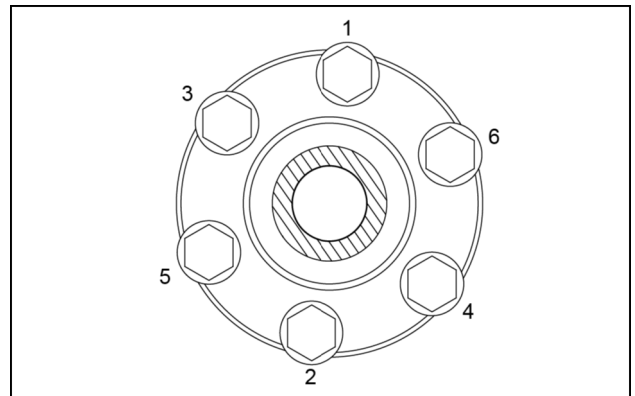

LEIL17WHL1383AA 7

9. Tighten to **130 – 140 N·m (96 – 103 lb ft)** (621G, 821G, 921G, 5-speed transmission).  
Follow the bolt installation pattern in figure.

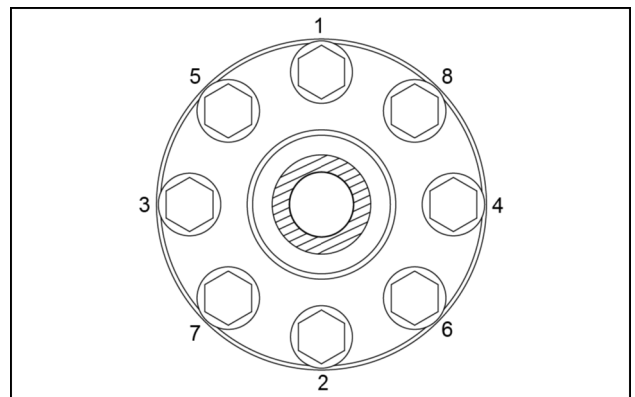

LEIL17WHL1382AA 8

10. Install the upper and lower drive shaft dust covers. Torque to **20 – 27 N·m (15 – 20 lb ft)**.

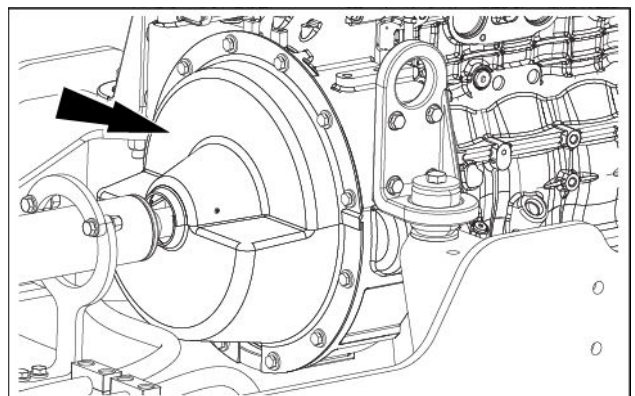

LEIL17WHL0048AB 9

11. At the noted location install additional spacer and clamp to route the fuel tank suction hose.

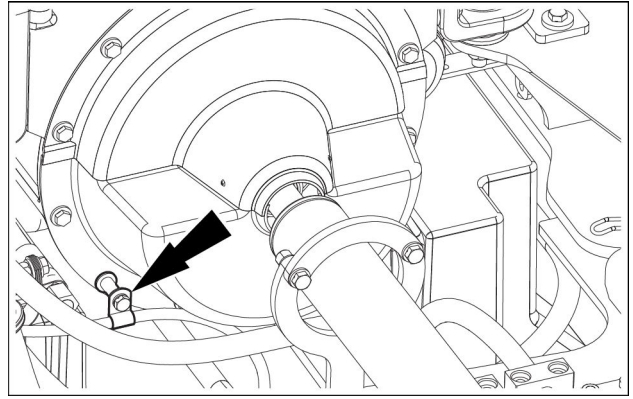

LEIL17WHL0086AB 10

12. Install the clamp (1) to secure the fuel return hose (2).
13. Connect the fuel line (2) to the top of the fuel filter.

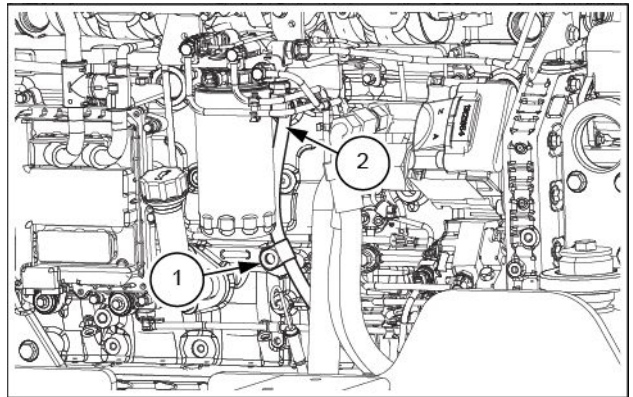

LEIL17WHL0046AB 11

14. Connect the FFH connector to the fuel filter.

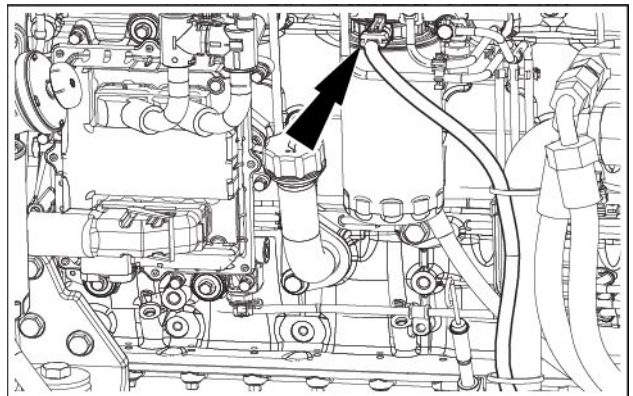

LEIL17WHL0049AB 12

15. Connect the EDC7 connector to the Engine Controller Unit (ECU).

**NOTE:** start the connector on the ECU with lever straight out from ECU. Use a lever to pull connector into position.

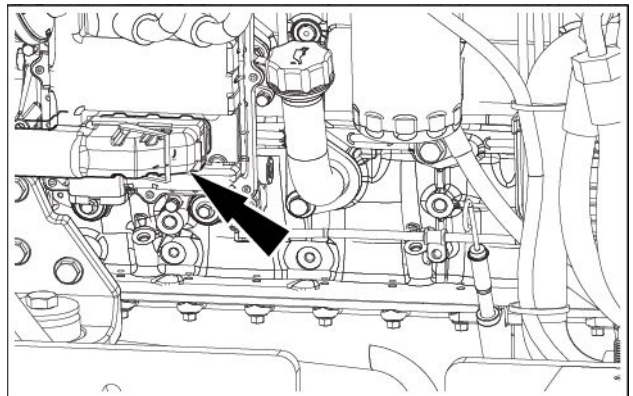

LEIL17WHL0050AB 13

16. Mount the engine starter (1). Firstly install the short threaded portion of the three studs (2) into the flywheel housing. Apply Loctite 747 primer to the studs and holes. Apply two drops of **LOCTITE® 271™** to each hole and stud assemble and torque immediately to **19 – 29 N·m (14 – 21 lb ft)**. Allow Loctite adhesive to cure **20 min** before installing the starter. Install the engine starter (1). Torque the three starter mounting nuts (3) to **40 – 50 N·m (29 – 37 lb ft)**.

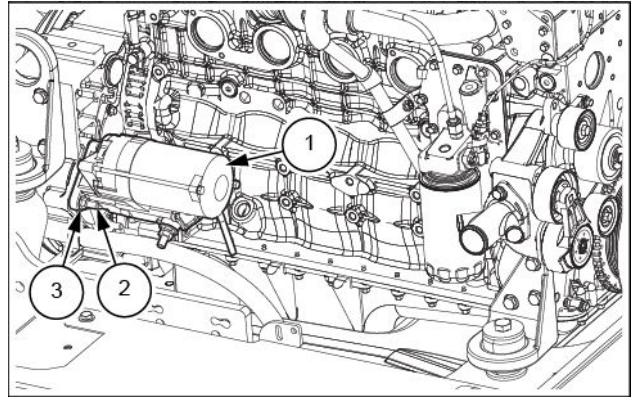

LEIL17WHL0052AB 14

17. Connect a suitable lifting device to the exhaust system assembly (1) (including muffler, pipe, support brackets) and carefully lift it. Position and lower the exhaust system assembly (1) over the rear chassis of the machine.

**NOTE:** be sure all wire harness connections and hoses are out of the way.

18. Install the muffler support brackets to the rear chassis with six bolts and washers (arrows).

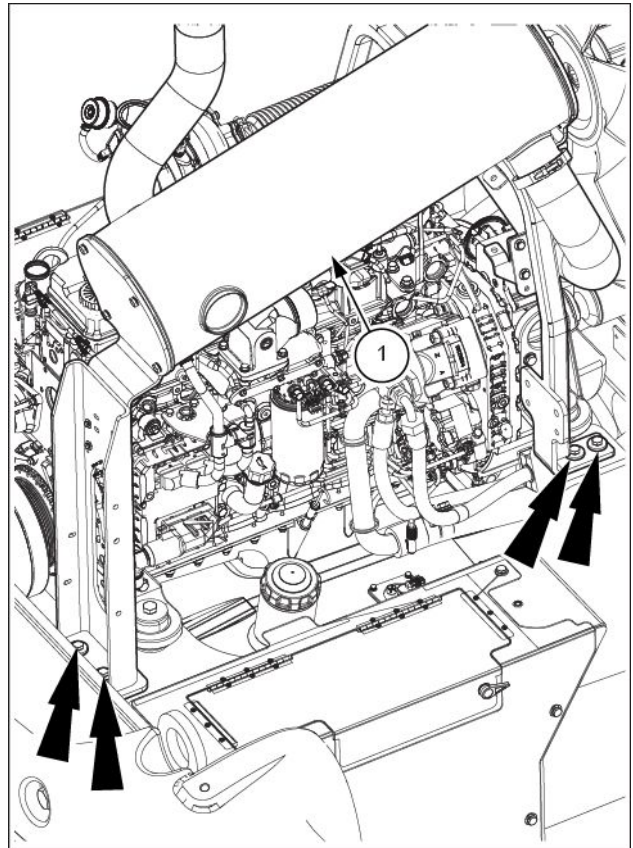

LEIL17WHL0053BB 15

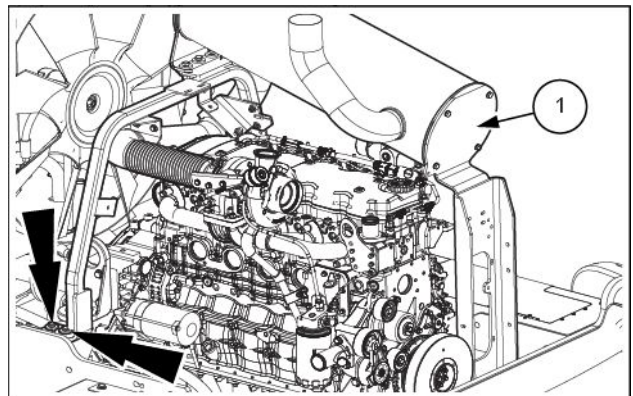

LEIL17WHL0051AB 16

19. Fix the end of the exhaust system pipe (1) to the engine with a new clamp (2). Tighten the clamp to **5.7 – 6.3 N·m (4.2 – 4.6 lb ft)**.

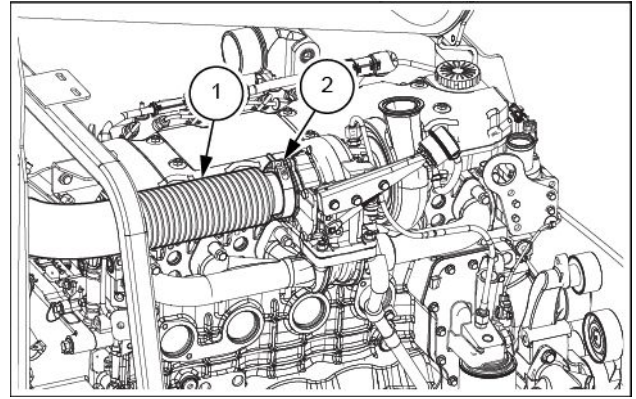

LEIL17WHL0054AB 17

20. Install the alarm back-up (1) to the rear muffler support with four bolts, washers (under bolt head and nut) and nuts. Connect wire O\_JB of connector BU1 to “NEG” and **35 A** of connector BU2 to “H1” (2) of alarm back-up. Secure the wire to the rear muffler support with cable ties.
21. Install the fuel pre-filter support bracket (3) to the rear muffler support with two bolts, washers (under bolt head and nut) and nuts.
22. Install the fuel pre-filter (4) to the support bracket with two bolts, washers (under bolt head and nut) and nuts. At this time connect the GRD\_WIF wire (5) by using the same hardware.
23. Connect the WIF connector (9) and WSH connector (6) to the fuel pre-filter.
24. Use the clamp (7) to secure the fuel tank suction hose to the rear muffler support.
25. Connect the fuel pre-filter to engine hose (8) to the engine.
26. Install the air intake cooling line (1) with clamps. Torque the clamps (2) at the ends mating the charge air cooler and engine to **10.1 – 11.3 N·m (7.4 – 8.3 lb ft)**.

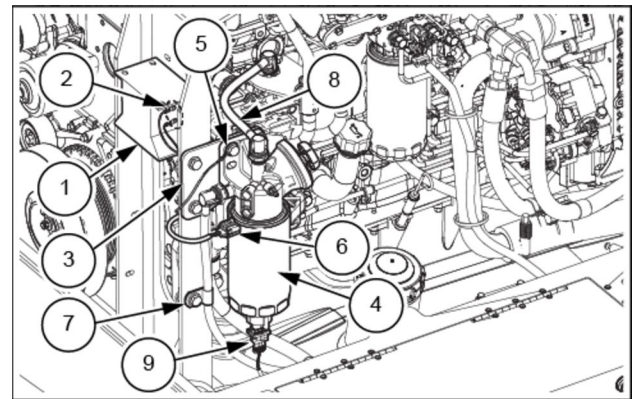

LEIL17WHL0055AB 18

**NOTE:** ensure clearance of **16.5 – 26.5 mm** between the charge air intake tube and the muffler.

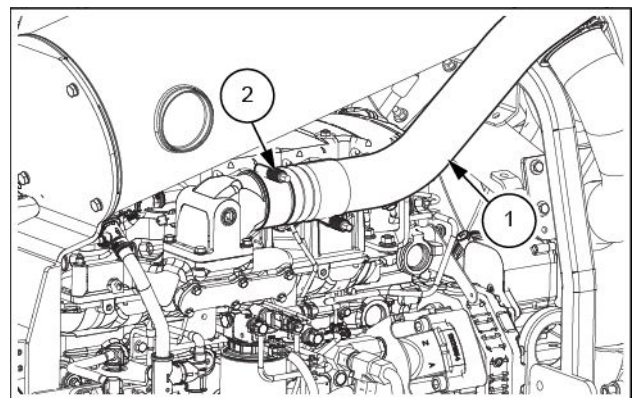

LEIL17WHL0090AB 19



**Suggest:**

**If the above button click is invalid.**

**Please download this document**

**first, and then click the above link**

**to download the complete manual.**

**Thank you so much for reading**

27. Install the turbo outlet air cooling line (1) with clamps. Torque the clamp at the end mating the charge air cooler to **10.1 – 11.3 N·m (7.4 – 8.3 lb ft)**. Install a new O-ring at the end mating the engine and torque the clamp (2) to **5.8 – 7.8 N·m (4.3 – 5.8 lb ft)**.

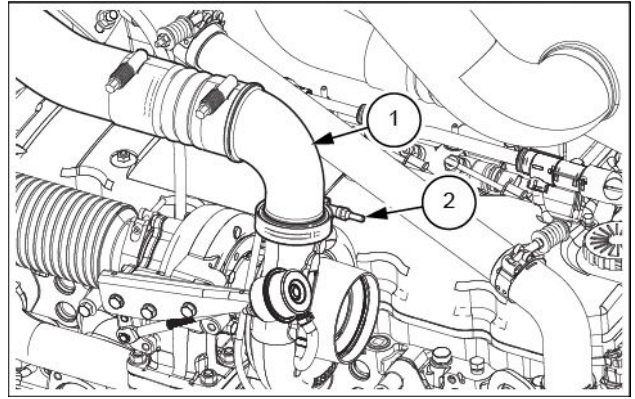

LEIL17WHL0091AB 20

28. Connect the bottom engine coolant line (1) to the engine with the clamp (2). Torque the clamp to **10.1 – 11.3 N·m (7.4 – 8.3 lb ft)**.

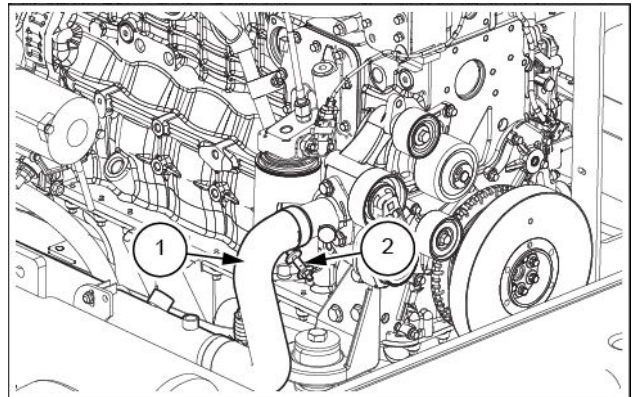

LEIL17WHL0092AB 21

29. Install the top cooling line (1) with clamps (2). Torque the clamps at the ends mating the elbow hose and engine to **10.1 – 11.3 N·m (7.4 – 8.3 lb ft)**.

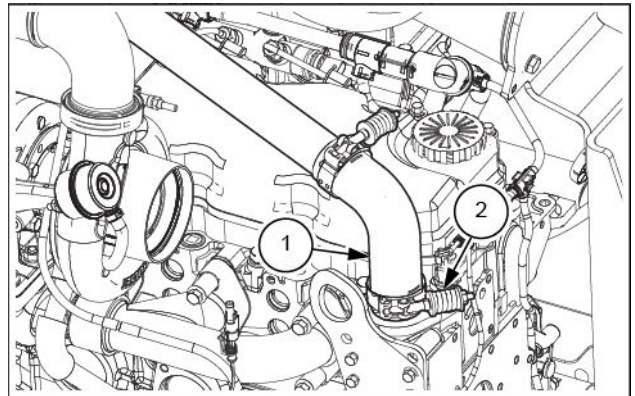

LEIL17WHL0093AB 22

30. Fix the top cooling line to the muffler support structure with U-bolt clamp.

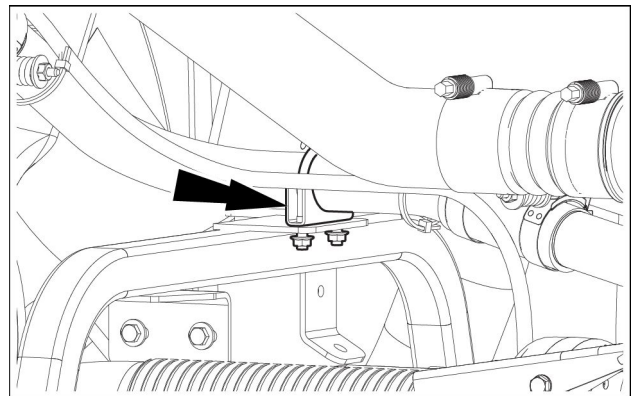

LEIL17WHL0095AB 23

**<https://www.ebooklibonline.com>**

Hello dear friend!

Thank you very much for reading.

Enter the link into your browser.

The full manual is available for immediate download.

**<https://www.ebooklibonline.com>**